

REVISIONS					
P	LTR	DESCRIPTION	DATE	DWN	APVD
S2		REVISED PER ECO-15-006450	28APR2015	NK	RH
S3		REVISED PER ECO-16-018654	15MAY2017	RK	PO
S4		REVISED PER ECO-17-012597	27OCT2017	RK	PO

SPECIFICATIONS:

MATERIAL

BASE, PPS, UL94V-0, BLACK
 COVER, PPS, UL94V-0, BLACK
 ACTUATOR, PA6T, UL94V-0, WHITE
 FIXED CONTACT/TERMINAL, CU ALLOY-GOLD FLASH OVER NICKEL
 MOVING CONTACT, CU ALLOY, PLATE-GOLD FLASH/NICKEL

ELECTRICAL

MAX CONTACT RATING SWITCHING, 100MILLIAMP @ 24 VDC
 MIN CONTACT RATING SWITCHING, .1MICROAMP @ 1 MILLIVOLT
 MAX CONTACT NON-SWITCHING, 1AMP @ 5 VDC
 INITIAL CONTACT RESISTANCE, 50 MILLIOHMS MAX.
 CONTACT RESISTANCE (AFTER ENVIRONMENTAL TEST), 100 MILLIOHMS
 CONTACT RESISTANCE (AFTER GAS TEST), 300 MILLIOHMS
 INSULATION RESISTANCE, 1,000 MEGOHMS MIN. @ 100 VDC
 DIELECTRIC STRENGTH, 500 VAC RMS @ SEA LEVEL
 LIFE EXPECTANCY, 1,000 CYCLES

MECHANICAL

OPERATING FORCE, LESS THAN 800 GRAMS
 CONTACT PRESSURE, 280,000 PSI

ENVIRONMENTAL

OPERATING TEMPERATURE, -30 TO +85 DEGREES C
 STORAGE TEMPERATURE, -45 TO +105 DEGREES C
 CLEANING, AQUEOUS OR SOLVENT
 SOLDER HEAT RESISTANCE, PER 109-201, COND B, SWITCH "OFF".
 SOLDERABILITY PER JIS C 0050 & JIS C 0053

- 1 SWITCHES TO BE RECEIVED IN THE "OFF" POSITION AND PACKAGED IN CLEAR TUBES TO ACCOMMODATE AUTO-INSERTION.
- 2 TOP SURFACE TO BE CLEARLY MARKED AS SHOWN.
- 3 SWITCHES TO BE BLACK WITH WHITE ACTUATORS AND MARKINGS.
- △ 4 TERMINAL OPTION: OLD T&B P/N ADExxS, SA OR SB
 S= OUTSIDE "L" TERMINALS; SA= INSIDE "L" TERMINALS;
 SB= BUTT TERMINALS.
- 5 ALL MATERIALS AND FINISHES SHALL COMPLY WITH EU DIRECTIVE 2002/95/EC OF 27JAN2003 (ROHS).
- △ 6 OBSOLETE PARTS: OBSOLETE CIS STREAMLINING PER D.RENAUD/D.SINISI.
- △ 7 TAPE AND REEL PACKING PER PAGE 3 SPECIFICATIONS.

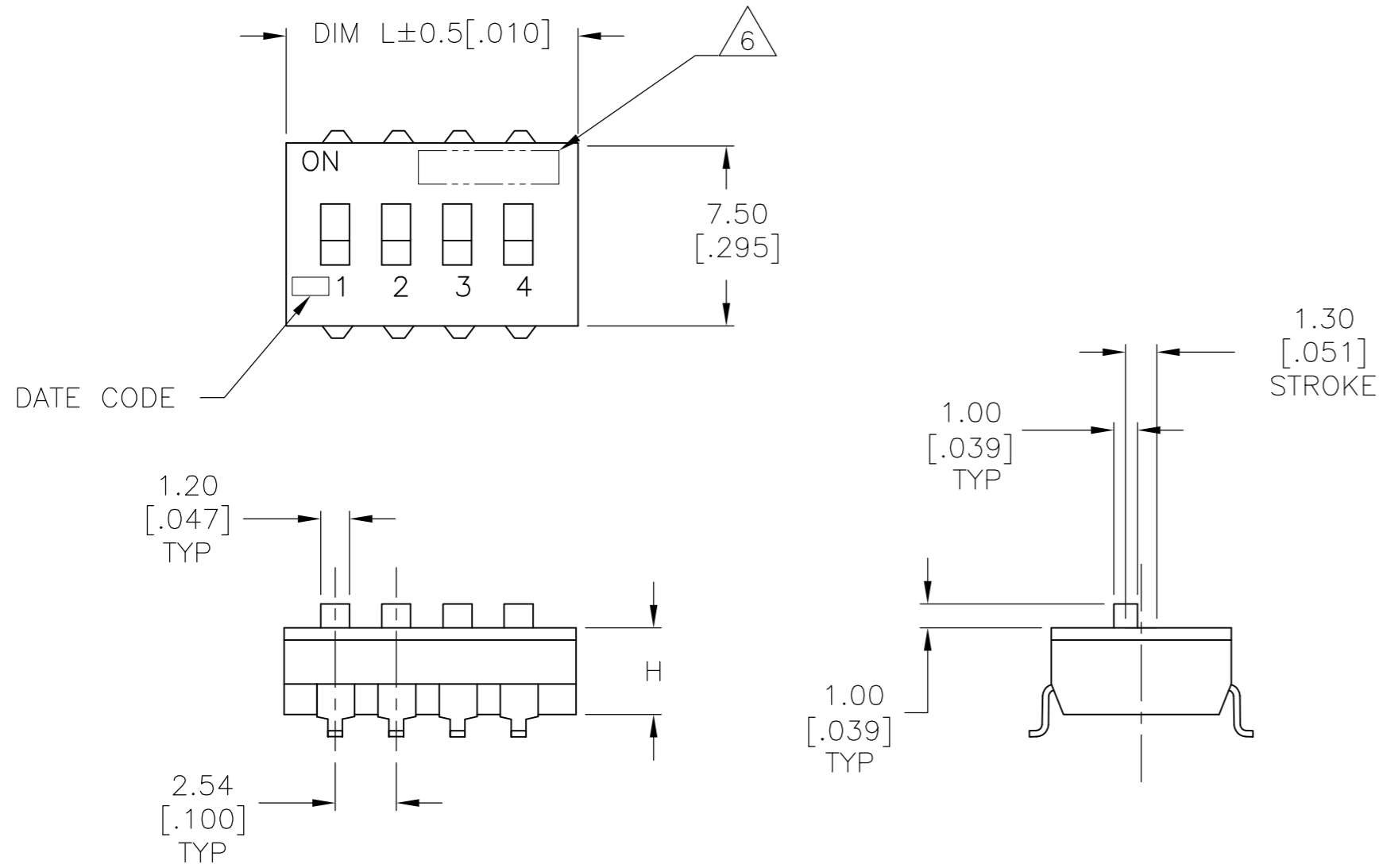

SEE SHEET 2 FOR PART NUMBER TABLE AND MOUNTING OPTIONS

THIS DRAWING IS A CONTROLLED DOCUMENT.		DWN B.S.VISWESWARA 10FEB05	TE Connectivity																			
DIMENSIONS: mm [INCHES]		CHK M.SARVER			NAME																	
TOLERANCES UNLESS OTHERWISE SPECIFIED:		APVD M.SARVER	DIP SWITCH, ADE-SMT SERIES																			
<table border="0"> <tr><td>0 PLC</td><td>±</td><td>-</td></tr> <tr><td>1 PLC</td><td>±</td><td>-</td></tr> <tr><td>2 PLC</td><td>±</td><td>0.30[.012]</td></tr> <tr><td>3 PLC</td><td>±</td><td>-</td></tr> <tr><td>4 PLC</td><td>±</td><td>-</td></tr> <tr><td>ANGLES</td><td>±</td><td>-</td></tr> </table>		0 PLC	±	-	1 PLC	±	-	2 PLC	±	0.30[.012]	3 PLC	±	-	4 PLC	±	-	ANGLES	±	-	PRODUCT SPEC	SIZE	
0 PLC	±	-																				
1 PLC	±	-																				
2 PLC	±	0.30[.012]																				
3 PLC	±	-																				
4 PLC	±	-																				
ANGLES	±	-																				
MATERIAL		APPLICATION SPEC	CAGE CODE	DRAWING NO	RESTRICTED TO																	
FINISH		WEIGHT	A2	1825058	-																	
		CUSTOMER DRAWING	SCALE	SHEET	REV																	
			4:1	1 of 3	S4																	

REVISIONS					
P	LTR	DESCRIPTION	DATE	DWN	APVD
-	-	SEE SHEET 1	-	-	-

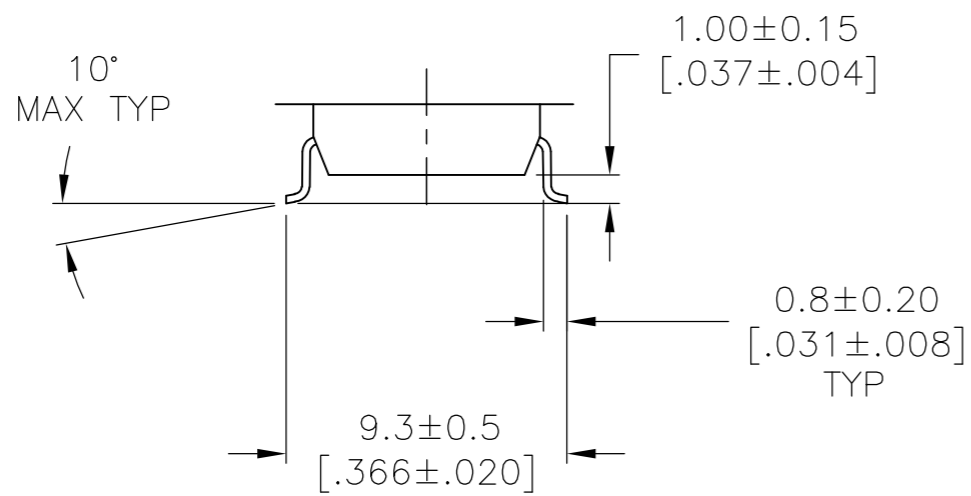
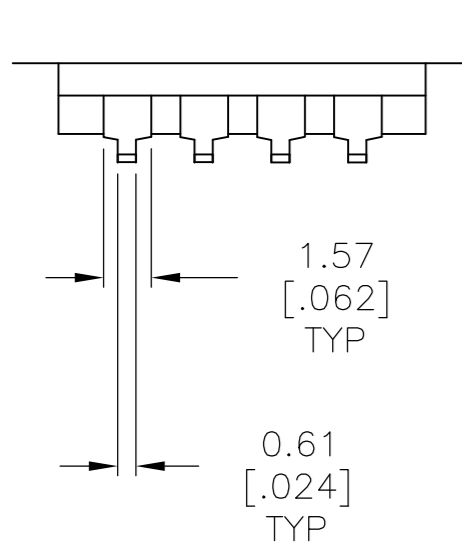

SURFACE MOUNT
S (OUTSIDE "L")

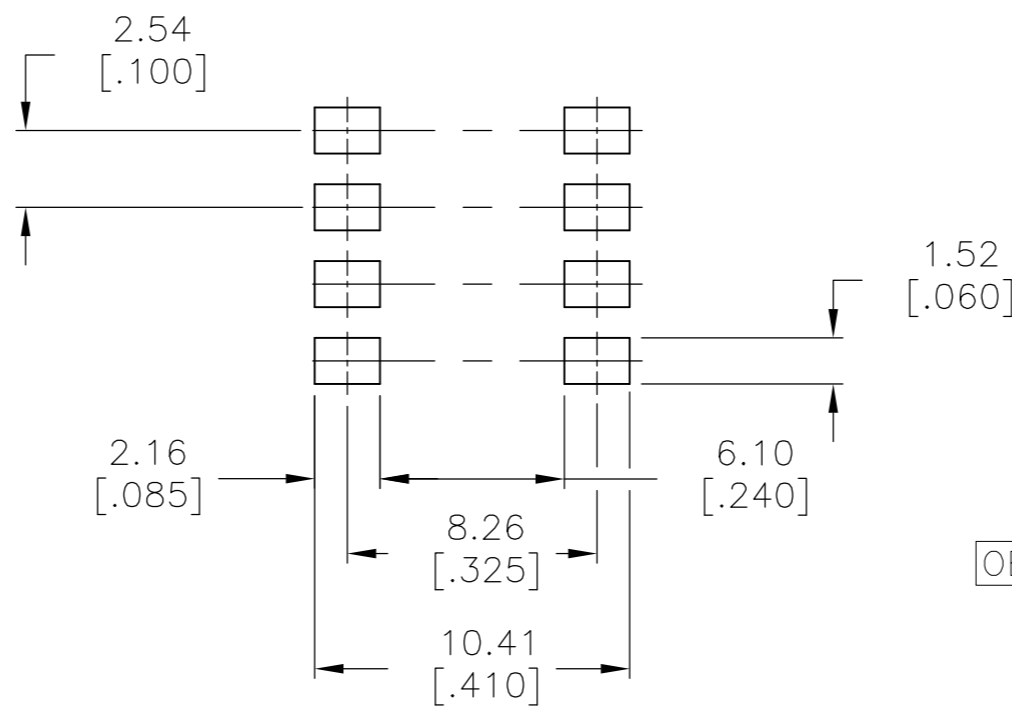

RECOMMENDED PAD LAYOUT

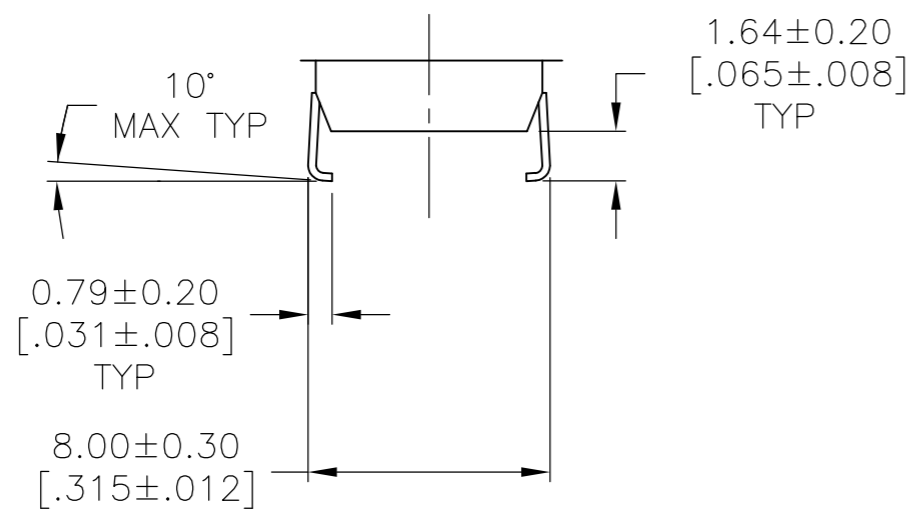
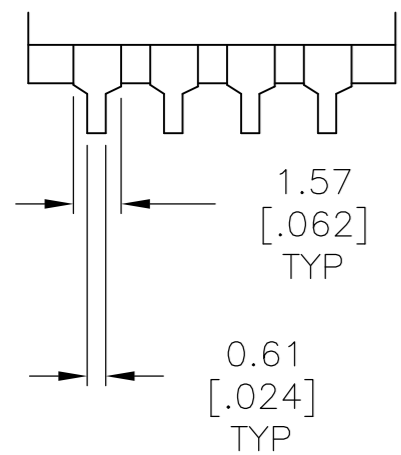

SURFACE MOUNT
SA (INSIDE "L")

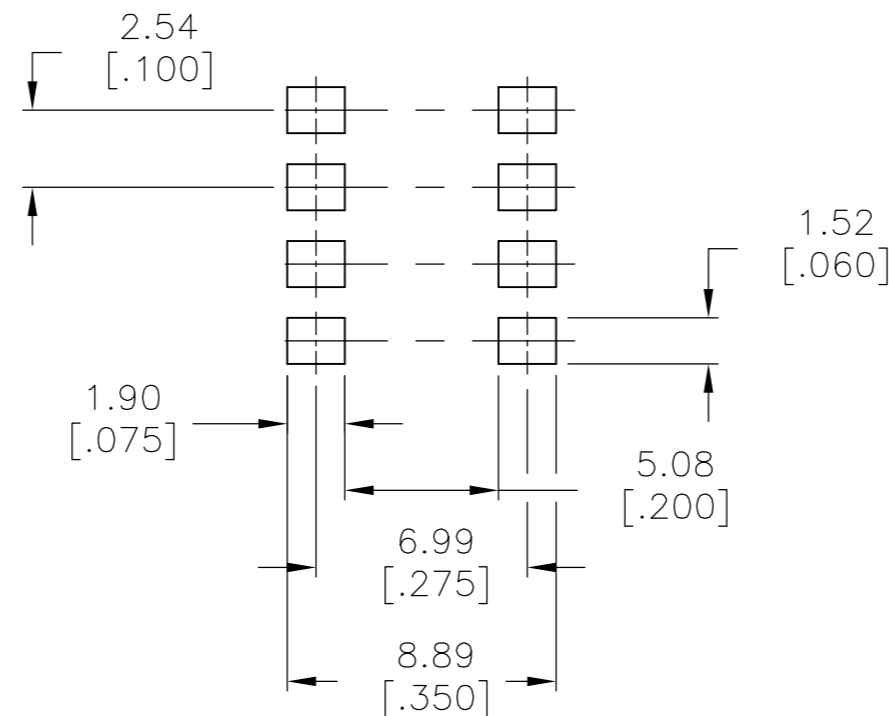

RECOMMENDED PAD LAYOUT

OBSOLETE	ADE12STR04	3.61 [.142]	32.51 [1.280]	12	4-1825058-1
	ADE10STR04	3.50 [.138]	27.30 [1.075]	10	4-1825058-0
	ADE09STR04	3.50 [.138]	24.54 [.978]	9	3-1825058-9
	ADE08STR04	3.50 [.138]	22.30 [.878]	8	3-1825058-8
OBSOLETE	ADE07STR04	3.50 [.138]	19.76 [.778]	7	3-1825058-7
	ADE06STR04	3.50 [.138]	17.22 [.678]	6	3-1825058-6
OBSOLETE	ADE05STR04	3.50 [.138]	14.68 [.578]	5	3-1825058-5
OBSOLETE	ADE04STR04	3.50 [.138]	12.14 [.478]	4	3-1825058-4
OBSOLETE	ADE03STR04	3.50 [.138]	9.60 [.378]	3	3-1825058-3
	ADE02STR04	3.50 [.138]	7.00 [.276]	2	3-1825058-2
	ADE04SATR04	3.50 [.138]	12.14 [.478]	4	3-1825058-1
OBSOLETE	ADE12SB04	3.61 [.142]	32.51 [1.280]	12	3-1825058-0
OBSOLETE	ADE12SA04	3.61 [.142]	32.51 [1.280]	12	2-1825058-9
OBSOLETE	ADE12S04	3.61 [.142]	32.51 [1.280]	12	2-1825058-8
OBSOLETE	ADE10SB04	3.50 [.138]	27.30 [1.075]	10	2-1825058-7
OBSOLETE	ADE10SA04	3.50 [.138]	27.30 [1.075]	10	2-1825058-6
	ADE10S04	3.50 [.138]	27.30 [1.075]	10	2-1825058-5
	ADE09SB04	3.50 [.138]	24.54 [.978]	9	2-1825058-4
	ADE09SA04	3.50 [.138]	24.54 [.978]	9	2-1825058-3
	ADE09S04	3.50 [.138]	24.54 [.978]	9	2-1825058-2
OBSOLETE	ADE08SB04	3.50 [.138]	22.30 [.878]	8	2-1825058-1
	ADE08SA04	3.50 [.138]	22.30 [.878]	8	2-1825058-0
	ADE08S04	3.50 [.138]	22.30 [.878]	8	1-1825058-9
OBSOLETE	ADE07SB04	3.50 [.138]	19.76 [.778]	7	1-1825058-8
	ADE07SA04	3.50 [.138]	19.76 [.778]	7	1-1825058-7
	ADE07S04	3.50 [.138]	19.76 [.778]	7	1-1825058-6
OBSOLETE	ADE06SB04	3.50 [.138]	17.22 [.678]	6	1-1825058-5
OBSOLETE	ADE06SA04	3.50 [.138]	17.22 [.678]	6	1-1825058-4
	ADE06S04	3.50 [.138]	17.22 [.678]	6	1-1825058-3
OBSOLETE	ADE05SB04	3.50 [.138]	14.68 [.578]	5	1-1825058-2
	ADE05SA04	3.50 [.138]	14.68 [.578]	5	1-1825058-1
	ADE05S04	3.50 [.138]	14.68 [.578]	5	1-1825058-0
	ADE04SB04	3.50 [.138]	12.14 [.478]	4	1825058-9
OBSOLETE	ADE04SA04	3.50 [.138]	12.14 [.478]	4	1825058-8
	ADE04S04	3.50 [.138]	12.14 [.478]	4	1825058-7
	ADE03SB04	3.50 [.138]	9.60 [.378]	3	1825058-6
	ADE03SA04	3.50 [.138]	9.60 [.378]	3	1825058-5
	ADE03S04	3.50 [.138]	9.60 [.378]	3	1825058-4
OBSOLETE	ADE02SB04	3.50 [.138]	7.00 [.276]	2	1825058-3
OBSOLETE	ADE02SA04	3.50 [.138]	7.00 [.276]	2	1825058-2
	ADE02S04	3.50 [.138]	7.00 [.276]	2	1825058-1
	T&B P/N	DIM H	DIM L	POSITION	PART NO.

THIS DRAWING IS A CONTROLLED DOCUMENT. DWN: B.S.VISWESWARA 10FEB05
 CHK: M.SARVER
 APVD: M.SARVER
 PRODUCT SPEC: -
 APPLICATION SPEC: -
 MATERIAL: - FINISH: - WEIGHT: -

STE TE Connectivity
 DIP SWITCH, ADE-SMT SERIES

SIZE: A2 CAGE CODE: - DRAWING NO: 1825058 RESTRICTED TO: -
 SCALE: 4:1 SHEET: 2 of 3 REV: S4

THIS DRAWING IS UNPUBLISHED. RELEASED FOR PUBLICATION 1825058, 1825058
 © COPYRIGHT 1825058 By - ALL RIGHTS RESERVED.

REVISIONS					
P	LTR	DESCRIPTION	DATE	DWN	APVD
-	-	SEE SHEET 1	-	-	-

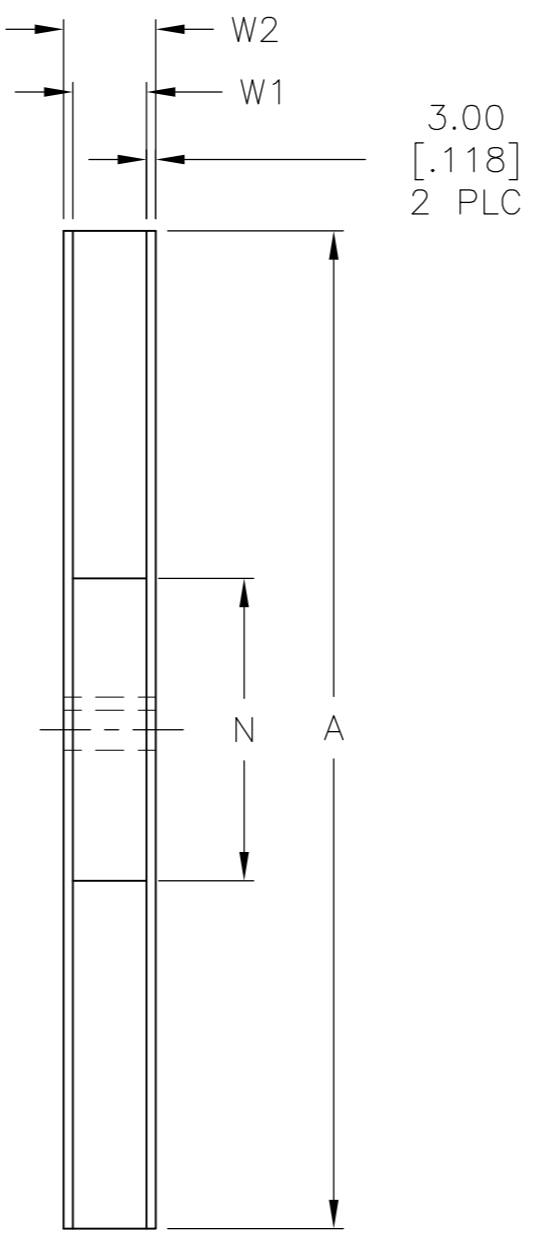
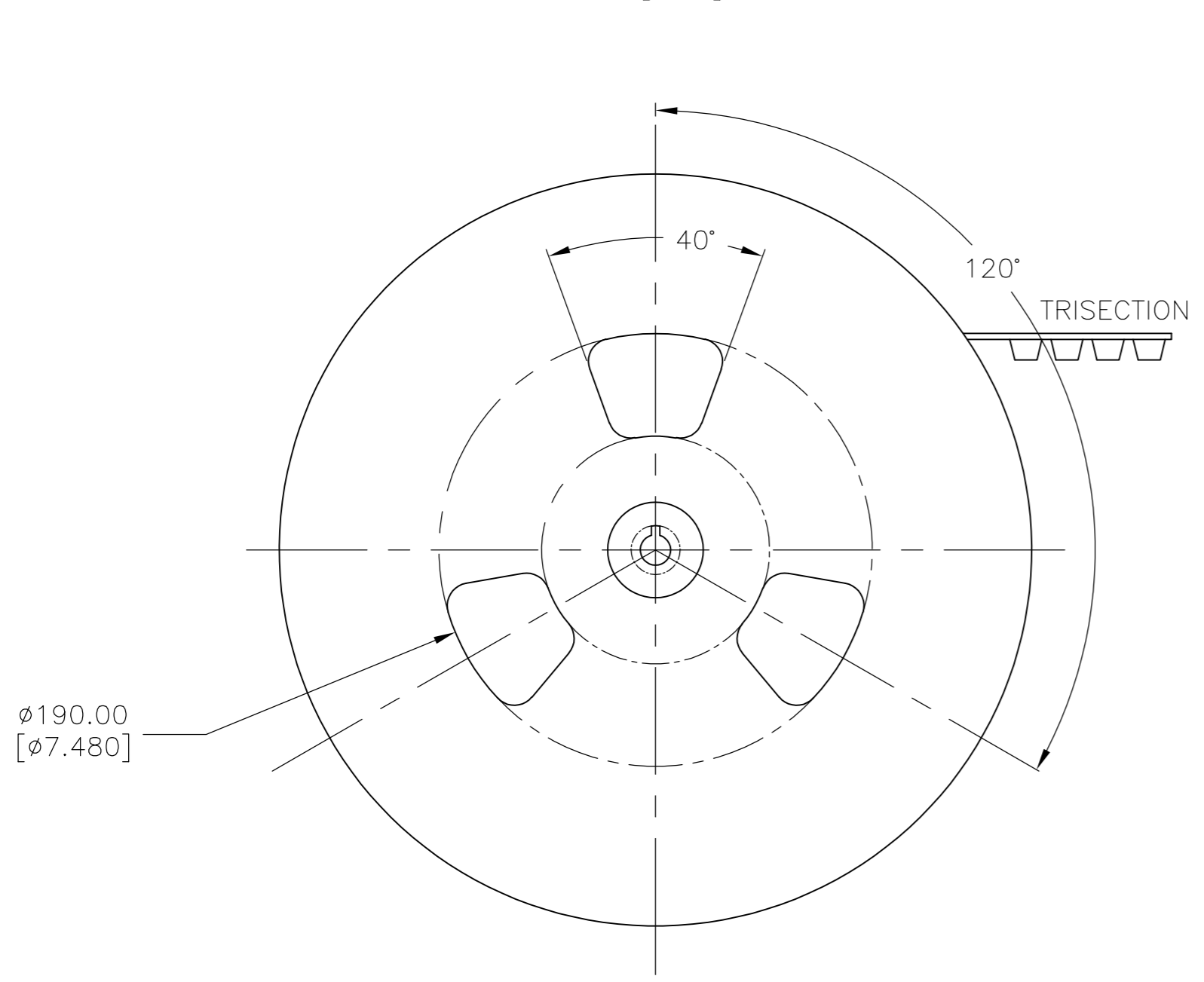
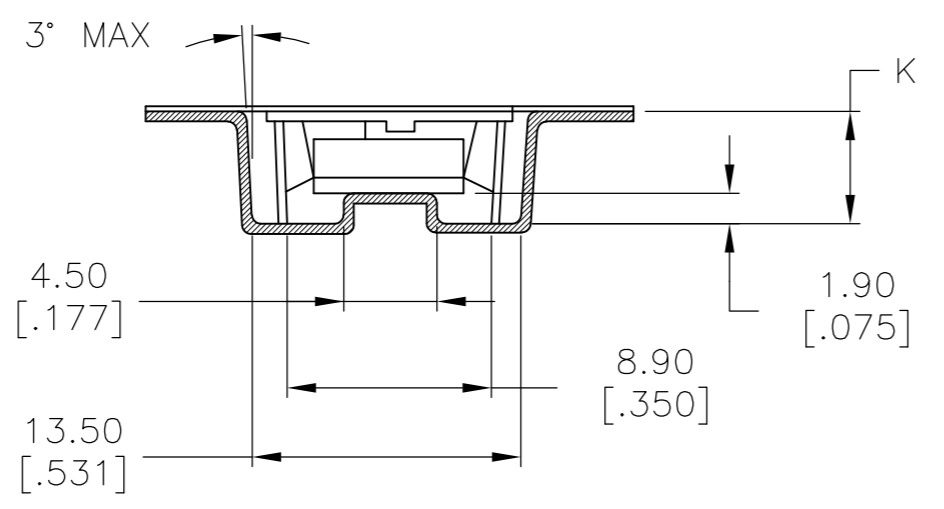
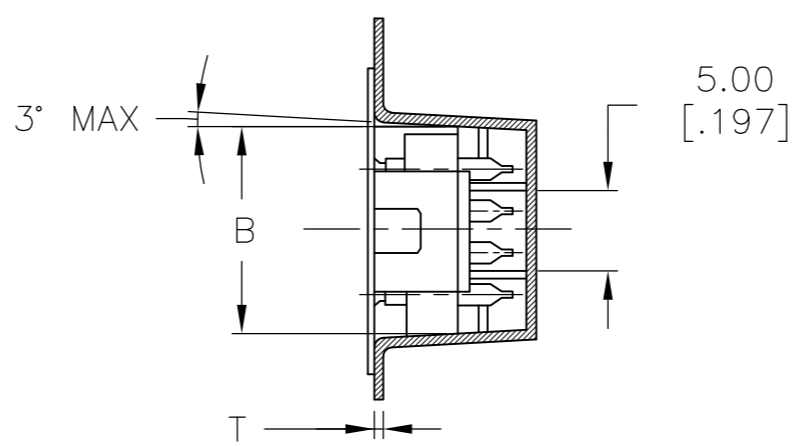
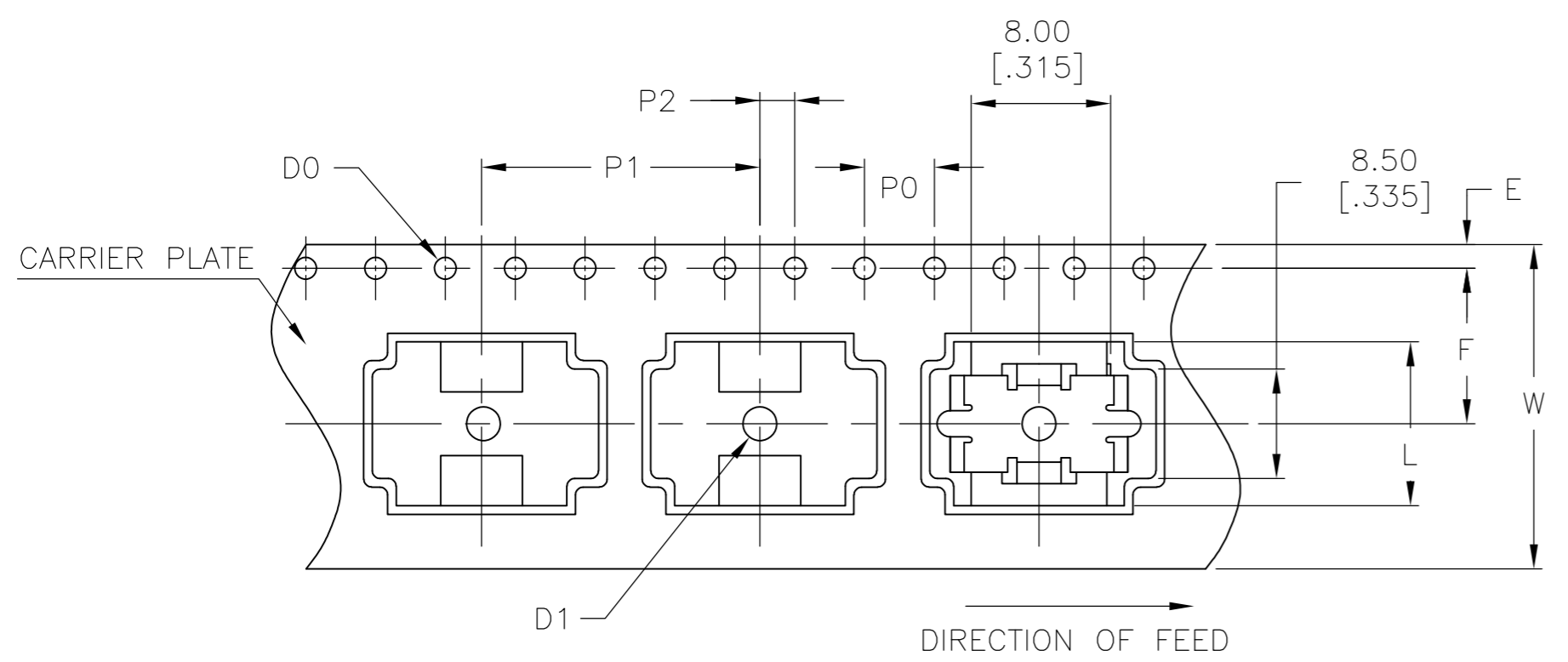

	DESCRIPTION	MATERIAL	DIMENSION	FINISH	REMARKS
1	REEL	SIDE: CARDBOARD CORE: STYLOFOAM	MENTIONED BELOW		
2	EMBOSSSED TAPE	-	MENTIONED BELOW	ANTISTATIC	BLACK
3	TOP COVER TAPE	-	MENTIONED BELOW	ANTISTATIC	TRANSPARENT

4P	ø330.00±2.10 [12.992±.082]	ø100 [3.940]	24.40 +2.00 [.960 +.790]	30.40 [1.997]
NO OF POSITION	A	N (MIN)	W1	W2 (MAX)

4P	ø1.50 +0.10 [ø.059+.003]	4.00±0.10 [.157±.003]	16.00±0.10 [.629±.003]	2.00±0.15 [.078±.005]	11.50±0.10 [.453±.003]	7.40±0.10 [.291±.003]
NO OF POSITION	D1	P0	P1	P2	F	K

4P	24.00±0.30 [.944±.011]	12.90±0.10 [.507±.003]	1.75±0.10 [.068±.003]	0.50±0.05 [.020±.001]	12.14±0.50 [.477±.020]	ø1.50+0.10 [ø.059+.003]
NO OF POSITION	W	B	E	T	L	DO

THIS DRAWING IS A CONTROLLED DOCUMENT. DWN: B.S.VISWESWARA 10FEB05
 CHK: M.SARVER
 APVD: M.SARVER
 PRODUCT SPEC: -
 APPLICATION SPEC: -
 MATERIAL: - FINISH: - WEIGHT: -

TE TE Connectivity
 DIP SWITCH, ADE-SMT SERIES

SIZE: A2 CAGE CODE: - DRAWING NO: C=1825058 RESTRICTED TO: -
 SCALE: 4:1 SHEET: 3 OF 3 REV: S4

CUSTOMER DRAWING



Компания «ЭлектроПласт» предлагает заключение долгосрочных отношений при поставках импортных электронных компонентов на взаимовыгодных условиях!

Наши преимущества:

- Оперативные поставки широкого спектра электронных компонентов отечественного и импортного производства напрямую от производителей и с крупнейших мировых складов;
- Поставка более 17-ти миллионов наименований электронных компонентов;
- Поставка сложных, дефицитных, либо снятых с производства позиций;
- Оперативные сроки поставки под заказ (от 5 рабочих дней);
- Экспресс доставка в любую точку России;
- Техническая поддержка проекта, помощь в подборе аналогов, поставка прототипов;
- Система менеджмента качества сертифицирована по Международному стандарту ISO 9001;
- Лицензия ФСБ на осуществление работ с использованием сведений, составляющих государственную тайну;
- Поставка специализированных компонентов (Xilinx, Altera, Analog Devices, Intersil, Interpoint, Microsemi, Aeroflex, Peregrine, Syfer, Eurofarad, Texas Instrument, Miteq, Cobham, E2V, MA-COM, Hittite, Mini-Circuits, General Dynamics и др.);

Помимо этого, одним из направлений компании «ЭлектроПласт» является направление «Источники питания». Мы предлагаем Вам помощь Конструкторского отдела:

- Подбор оптимального решения, техническое обоснование при выборе компонента;
- Подбор аналогов;
- Консультации по применению компонента;
- Поставка образцов и прототипов;
- Техническая поддержка проекта;
- Защита от снятия компонента с производства.



Как с нами связаться

Телефон: 8 (812) 309 58 32 (многоканальный)

Факс: 8 (812) 320-02-42

Электронная почта: org@eplast1.ru

Адрес: 198099, г. Санкт-Петербург, ул. Калинина, дом 2, корпус 4, литера А.