

Amphenol EP-Octal-1G Octal 1G Base-T to SGMII Converter

Amphenol Aerospace adds 1G Base-T to SGMII Converter to the Electronics Product Family. This product line is rugged, flexible, and affordable with many options available.

The 1G Base-T to SGMII Converter couples SerDes technology and protocol conversion with a new level of ruggedization.

Features & Benefits:

- 8 Bi-directional Ethernet Channels
- Conversion of 1G Base-T to SGMII
- Compliant with IEEE 802.3 Ethernet Standards and Specifications
- Hermetic option available with a helium leak rate of 10^{-4} cc/sec

1G Base-T Copper Interface:

- D389999 Shell Size 19
- Size 22 contacts

SGMII Interface:

- Samtec EQDP Series for high speed SGMII, power, and MDC/MDIO control

Power Specifications:

- 5V power connection in Samtec connector
- Low power consumption

Ruggedization:

- Natural convection cooled (no fan)
- Operational temperature -40°C to $+85^{\circ}\text{C}$
- Shock, vibration, immersion resistant per MIL-STD-810



Amphenol EP-Octal-16

Drawing for both Hermetic & Non-Hermetic Configurations

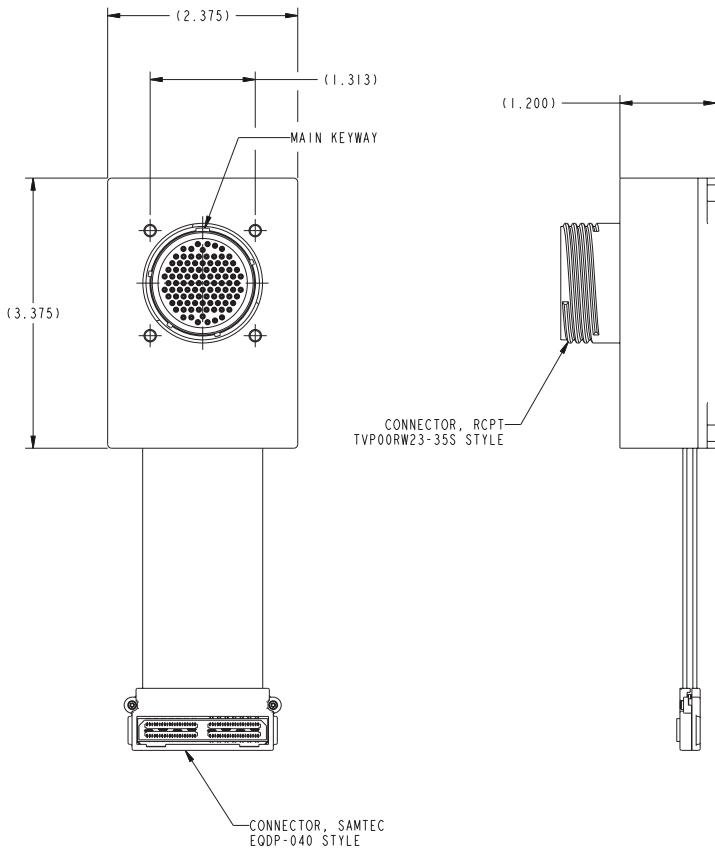

Drawing for Test Cable CA-628485-A2()

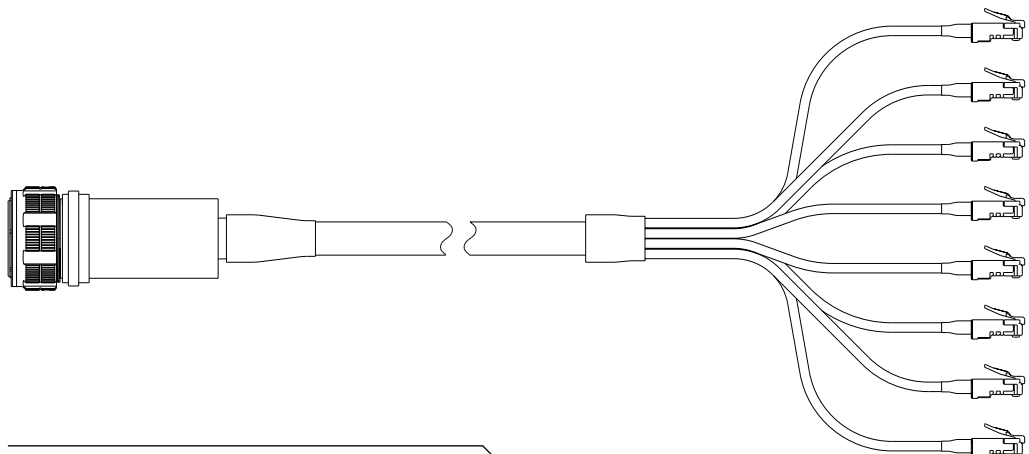

Amphenol EP-Octal-16

Pin outs

MIL-DTL-38999 Shell Size 23-25 size 22D pins

Pin	Description	Pin	Description	Pin	Description	Pin	Description
1	CH 1 A+	26	Ground	51	CH 5 A+	76	Ground
2	CH 2 A+	27	CH 4 A+	52	CH 5 A-	77	CH 7 A+
3	CH 2 A-	28	Ground	53	Ground	78	CH 7 A-
4	Ground	29	Ground	54	CH 5 B+	79	CH 7 B+
5	CH 2 B+	30	Ground	55	CH 5 B-	80	CH 7 B-
6	CH 2 B-	31	Ground	56	CH 6 A+	81	CH 7 C+
7	Ground	32	Ground	57	Ground	82	CH 8 A+
8	CH 1 A-	33	CH 3 D+	58	CH 6 B+	83	CH 8 A-
9	CH 1 B+	34	CH 3 D-	59	CH 6 B-	84	CH 8 B+
10	Ground	35	CH 1 C-	60	Ground	85	Ground
11	CH 2 C+	36	CH 1 D+	61	CH 5 C+	86	Ground
12	CH 2 C-	37	CH 4 A-	62	CH 5 C-	87	CH 7 D+
13	Ground	38	Ground	63	Ground	88	CH 7 D-
14	CH 2 D+	39	CH 4 B+	64	CH 5 D+	89	CH 7 C-
15	CH 2 D-	40	CH 4 B-	65	CH 5 D-	90	Ground
16	CH 1 B-	41	Ground	66	Ground	91	CH 8 C+
17	Ground	42	CH 4 C+	67	CH 6 A-	92	Ground
18	CH 3 A+	43	CH 4 C-	68	Ground	93	CH 8 B-
19	CH 3 A-	44	Ground	69	CH 6 C+	94	Ground
20	CH 3 B+	45	Ground	70	CH 6 C-	95	Ground
21	CH 3 B-	46	CH 1 D-	71	Ground	96	Ground
22	CH 3 C+	47	Ground	72	CH 6 D+	97	CH 8 C-
23	CH 3 C-	48	CH 4 D+	73	CH 6 D-	98	Spare
24	Ground	49	CH 4 D-	74	Spare	99	CH 8 D+
25	CH 1 C+	50	Spare	75	Spare	100	CH 8 D-

Samtec EQDP - 40 pins

Pin	Description	Pin	Description
1	CH 1 Tx+	21	CH 6 Tx+
2	CH 1 Tx-	22	CH 6 Tx-
3	CH 1 Rx+	23	CH 6 Rx+
4	CH 1 Rx-	24	CH 6 Rx-
5	CH 2 Tx+	25	CH 7 Tx+
6	CH 2 Tx-	26	CH 7 Tx-
7	CH 2 Rx+	27	CH 7 Rx+
8	CH 2 Rx-	28	CH 7 Rx-
9	CH 3 Tx+	29	CH 8 Tx+
10	CH 3 Tx-	30	CH 8 Tx-
11	CH 3 Rx+	31	CH 8 Rx+
12	CH 3 Rx-	32	CH 8 Rx-
13	CH 4 Tx+	33	5V Power
14	CH 4 Tx-	34	Ground
15	CH 4 Rx+	35	MDC
16	CH 4 Rx-	36	MDIO
17	CH 5 Tx+	37	Spare
18	CH 5 Tx-	38	Spare
19	CH 5 Rx+	39	Spare
20	CH 5 Rx-	40	Spare

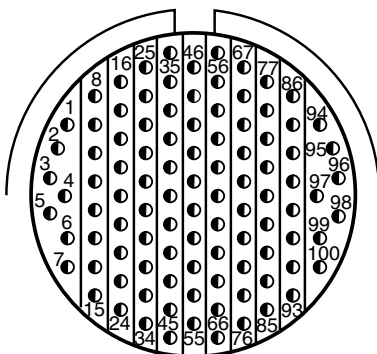

Amphenol EP-Octal-1G

How to Order

Ordering procedure is shown below using part number EP-

1.	2.	3.	4.	5.	6.	7.	8.
Connector Type	Material	SGMII Interface	Finish	Shell Style	Option (Hermetic or Non-Hermetic)	D38999 Connector Rotation	Main Keyway Rotation
EP							

Step 1. Connector Type

	Designates
EP	Electronics Product Family

Step 2. Select a Material

	Designates
-5	Aluminum Shell
-6	Composite Shell
-8	Stainless Steel Shell

Step 3. Select a SGMII Interface

	Designates
-5	Samtec EQDP Series Connector

Step 4. Select a Finish

	Designates
T	Aluminum Durmalon
Z	Aluminum Black Zinc Nickel
F	Aluminum Electroless Nickel
M	Composite Electroless Nickel
W	Aluminum OD Cad
J	Composite OD Cad
L	Stainless Steel Electrodeposited Nickel
Y	Stainless Steel Passivated

Step 5. Select a Shell Style

	Designates
0	Wall Mount

Step 6. Select an Option

	Designates
05	Non-Hermetic
06	Hermetic

Step 7. Select a Rotation for D38999 Connector

(IAW MIL-DTL-38999)

	Designates
N	N
A	A
B	B
C	C
D	D

Step 8. Select a Rotation for Main Keyway

(IAW MIL-DTL-38999)

	Designates
W	0°
X	90°
Y	180°
Z	270°

Available Test Equipment

	Part Number	Description
Test Cable	CA-628485-A30	RJ45 Test Cable for D38999 Connector, 5'
	CA-62848-A31	RJ45 Test Cable for D38999 Connector, 10'
	CA-62848-A32	RJ45 Test Cable for D38999 Connector, 15'
	CA-62848-A33	RJ45 Test Cable for D38999 Connector, 20'
Test Board	CF-020005-013	SMA Test Board for Samtec Connector

Notice: Specifications are subject to change without notice. Contact your nearest Amphenol Corporation Sales Office for the latest specifications. All statements, information and data given herein are believed to be accurate and reliable but are presented without guarantee, warranty, or responsibility of any kind, expressed or implied. Statements or suggestions concerning possible use of our products are made without representation or warranty that any such use is free of patent infringement and are not recommendations to infringe any patent. The user should assume that all safety measures are indicated or that other measures may not be required. Specifications are typical and may not apply to all connectors.

Amphenol
Aerospace

AMPHENOL is a registered trademark of Amphenol Corporation. ©2014 Amphenol Corporation 8/2014

Call 800-678-0141 or visit us at www.amphenol-aerospace.com



Компания «ЭлектроПласт» предлагает заключение долгосрочных отношений при поставках импортных электронных компонентов на взаимовыгодных условиях!

Наши преимущества:

- Оперативные поставки широкого спектра электронных компонентов отечественного и импортного производства напрямую от производителей и с крупнейших мировых складов;
- Поставка более 17-ти миллионов наименований электронных компонентов;
- Поставка сложных, дефицитных, либо снятых с производства позиций;
- Оперативные сроки поставки под заказ (от 5 рабочих дней);
- Экспресс доставка в любую точку России;
- Техническая поддержка проекта, помощь в подборе аналогов, поставка прототипов;
- Система менеджмента качества сертифицирована по Международному стандарту ISO 9001;
- Лицензия ФСБ на осуществление работ с использованием сведений, составляющих государственную тайну;
- Поставка специализированных компонентов (Xilinx, Altera, Analog Devices, Intersil, Interpoint, Microsemi, Aeroflex, Peregrine, Syfer, Eurofarad, Texas Instrument, Miteq, Cobham, E2V, MA-COM, Hittite, Mini-Circuits, General Dynamics и др.);

Помимо этого, одним из направлений компании «ЭлектроПласт» является направление «Источники питания». Мы предлагаем Вам помощь Конструкторского отдела:

- Подбор оптимального решения, техническое обоснование при выборе компонента;
- Подбор аналогов;
- Консультации по применению компонента;
- Поставка образцов и прототипов;
- Техническая поддержка проекта;
- Защита от снятия компонента с производства.



Как с нами связаться

Телефон: 8 (812) 309 58 32 (многоканальный)

Факс: 8 (812) 320-02-42

Электронная почта: org@eplast1.ru

Адрес: 198099, г. Санкт-Петербург, ул. Калинина, дом 2, корпус 4, литера А.