

Future Technology Devices International Datasheet ME812AU-WH50R Display Module



General Purpose Multi Media Controller

1 Introduction

The ME812AU-WH50R is a development module for Bridgetek's FT812, Embedded Video Engine (EVE) graphics controller IC. This module behaves as a USB device, with an FT4222H USB to SPI bridge built on-board so that the module can be accessed from a PC or any other USB host.

The ME812AU-WH50R module includes a 5.0 inch 800*480 TFT LCD panel with resistive touch screen, and an audio amplifier to drive 8Ω speaker.

1.1 Features

The ME812AU-WH50R module utilises the FT812, Bridgetek's 2nd generation EVE chip. Graphic, audio and touch functions of the FT812 can be accessed with the ME812AU-WH50R. For a full list of the FT812's features, refer to the [FT81x datasheet](#).

The ME812AU-WH50R has the following features:

- Ready to use 5 inch WVGA LCD module.
- Supports portrait and landscape display mode.
- Bright backlight LED with dimming.
- Supports resistive touch with pressure sensing.
- Supports mono audio from the FT812 or an external source.
- On board audio amplifier for an external 1W speaker.
- Support USB bus power.
- Support USB high speed connection to PC or other USB host.
- Comes with bezel with four mounting holes for easy system assembly.

Neither the whole nor any part of the information contained in, or the product described in this manual, may be adapted or reproduced in any material or electronic form without the prior written consent of the copyright holder. This product and its documentation are supplied on an as-is basis and no warranty as to their suitability for any particular purpose is either made or implied. Future Technology Devices International Ltd will not accept any claim for damages howsoever arising as a result of use or failure of this product. Your statutory rights are not affected. This product or any variant of it is not intended for use in any medical appliance, device or system in which the failure of the product might reasonably be expected to result in personal injury. This document provides preliminary information that may be subject to change without notice. No freedom to use patents or other intellectual property rights is implied by the publication of this document. Future Technology Devices International Ltd, Unit 1, 2 Seaward Place, Centurion Business Park, Glasgow G41 1HH United Kingdom. Scotland Registered Company Number: SC136640

2 Ordering Information

Part No.	Description
ME812AU-WH50R	FT812 development module, with FT4222H USB interface, 5.0 inch 800*480 TFT LCD resistive touch panel preinstalled. Black bezel.
CleO-SPK1	Accessory - 8Ω 1W speaker enclosure with connecting wires
VA-FC-1M-BKW	Accessory - Flat USB A to Micro B Cable 1M- Black and White
VA-FC-1M-BLW	Accessory - Flat USB A to Micro B Cable 1M- Blue and White
VA-FC-STYLUS1	Accessory - Resistive Touch Screen Pen Stylus

Table 2-1 – Ordering information

Table of Contents

1	Introduction	1
1.1	Features.....	1
2	Ordering Information	2
3	Board Interface Description	4
3.1	Board Profile.....	4
3.2	CN100- Micro USB receptacle.....	4
3.3	CN13- Audio connector	5
4	Specifications.....	6
4.1	Electrical Specification	6
4.2	Display Specification	6
4.3	Optical Specification	7
5	Board Schematics.....	9
6	Mechanical Dimensions	12
6.1	Module Dimensions.....	12
6.2	Bezel Mechanical Drawing.....	13
7	Getting Started.....	14
7.1	Hardware Setup	14
7.2	Software Setup	14
8	Contact Information.....	15
	Appendix A - References	16
	Document References	16
	Acronyms and Abbreviations	16
	Appendix B - List of Figures and Tables	17
	List of Figures	17
	List of Tables.....	17
	Appendix C – Revision History	18

3 Board Interface Description

The ME812AU-WH50R module is intended for direct use into existing applications that require a display. This module is suitable for interfacing with a PC or other USB host.

3.1 Board Profile

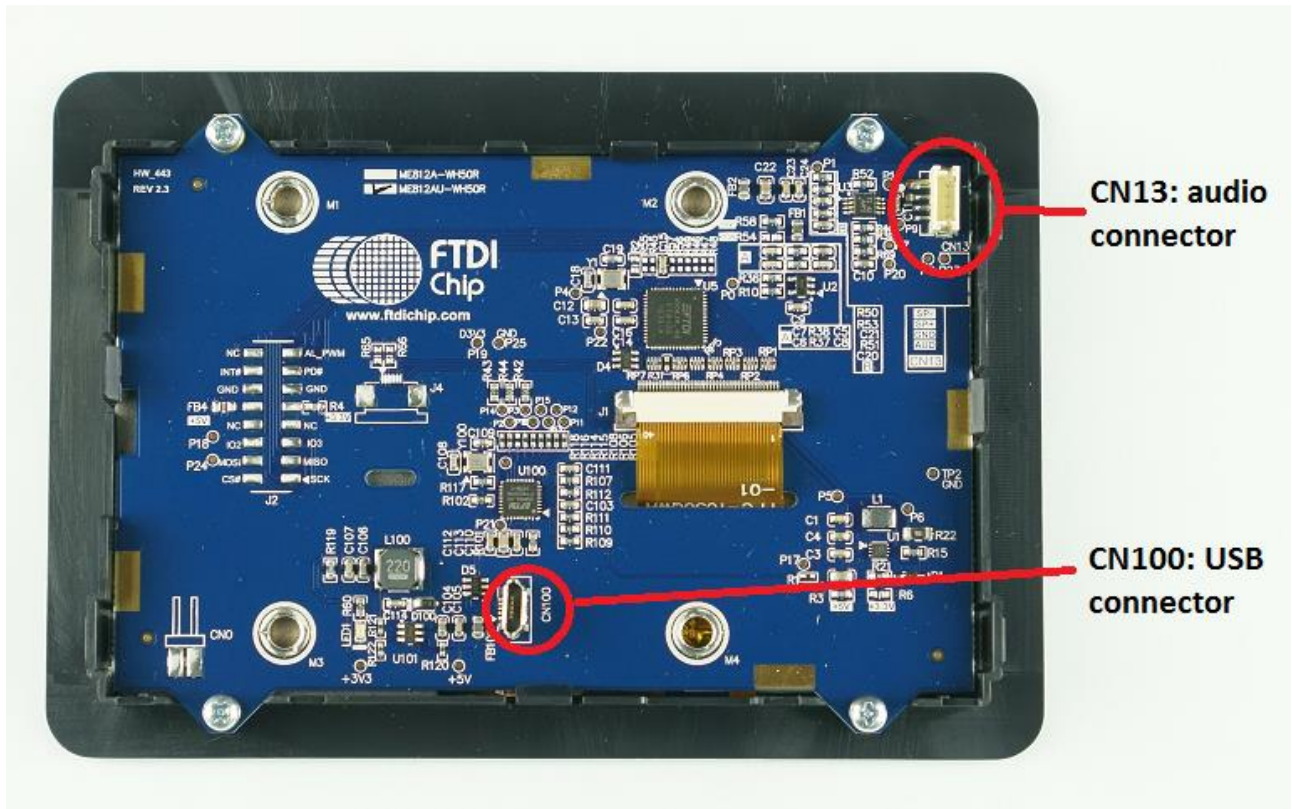

Figure 3-1 – ME812AU-WH50R board bottom view

3.2 CN100- Micro USB receptacle

CN100 is a micro USB connector. When the USB host is connected, the host controls the ME812AU-WH50R module functions through the FT4222H USB-to-SPI bridge.

Pin No.	Name	Type	Description
1	VBUS	P	USB VBUS +5V power supply
2	D-	I/O	USB D- data line
3	D+	I/O	USB D+ data line
4	NC	-	No connection
5	GND	P	Ground

Table 3-1 – CN100 pin description

3.3 CN13- Audio connector

The ME812AU-WH50R supports a mono speaker output through CN13. A PWM audio signal from the FT812 goes through a 3-stage RC filter and the audio amplifier, to drive into the 8Ω speaker if connected. Maximum output power to the speaker is 1 Watt. A readymade speaker module (CleO-SPR1) is available from Bridgetek.

An alternative, mono line-in audio input is also provided on CN13. Users can drive their own audio source in to the on board power amplifier.

Pin No.	Name	Type	Description
1	SP-	O	8Ω speaker minus terminal
2	SP+	O	8Ω speaker plus terminal
3	AGND	P	Audio ground
4	AUD_IN	I	Audio Line IN

Table 3-2 – CN13 pin description

4 Specifications

4.1 Electrical Specification

Parameter	Description	Minimum	Typical	Maximum	Units	Notes
VCC	VBUS supply voltage	4.5	5.0	5.5	V	USB power
Icc1	VBUS operating current	-	400	-	mA	With LCD and Backlight LED on
Icc2	VBUS operating current	-	800	-	mA	With 1W speaker (assumes user has powered the module from a USB charging hub or USB3.0 port)
T	Operating temperature	-20	-	+70	°C	

Table 4-1 - Operating Voltage and Current

4.2 Display Specification

Item	Spec	Units	Notes
LCD Type	TFT active matrix	-	
Display Colours	16.7M	-	
Display active area	108.0(H) * 64.8(V)	mm	5.0 inch diagonal
Number of Pixels	800(RGB)*480	dots	
Pixel pitch	0.135(H) * 0.135(V)	mm	
LED numbers	18 white LEDs	-	
Touch screen	4-wire resistive touch	-	

Table 4-2 - LCD and Touch Information

4.3 Optical Specification

Brightness (With TP)	Bp	$\theta=0^\circ$		400	-	Cd/m ²
Uniformity	ΔBp	$\Phi=0^\circ$	75	-	-	%
Viewing Angle	3:00	Cr \geq 10	-	60	-	Deg
	6:00		-	45	-	
	9:00		-	60	-	
	12:00		-	60	-	
Contrast Ratio	Cr	$\theta=0^\circ$ $\Phi=0^\circ$	300	500		-
Response Time	T _r		-	10	-	ms
	T _f		-	10	-	ms
Color of CIE Coordinate	W	x		0.28		-
		y		0.33		-
	R	x		0.51		-
		y		0.34		-
	G	x	$\theta=0^\circ$	0.31		-
		y	$\Phi=0^\circ$	0.56		-
	B	x		0.15		-
		y		0.14		-
NTSC Ratio	S		50	60	-	%

Table 4-3 - 5.0" TFT Optical specification

Note: The definition of viewing angle: refer to the figures below (if looking at the reverse side of the module the FTDI logo on the PCB is facing down).

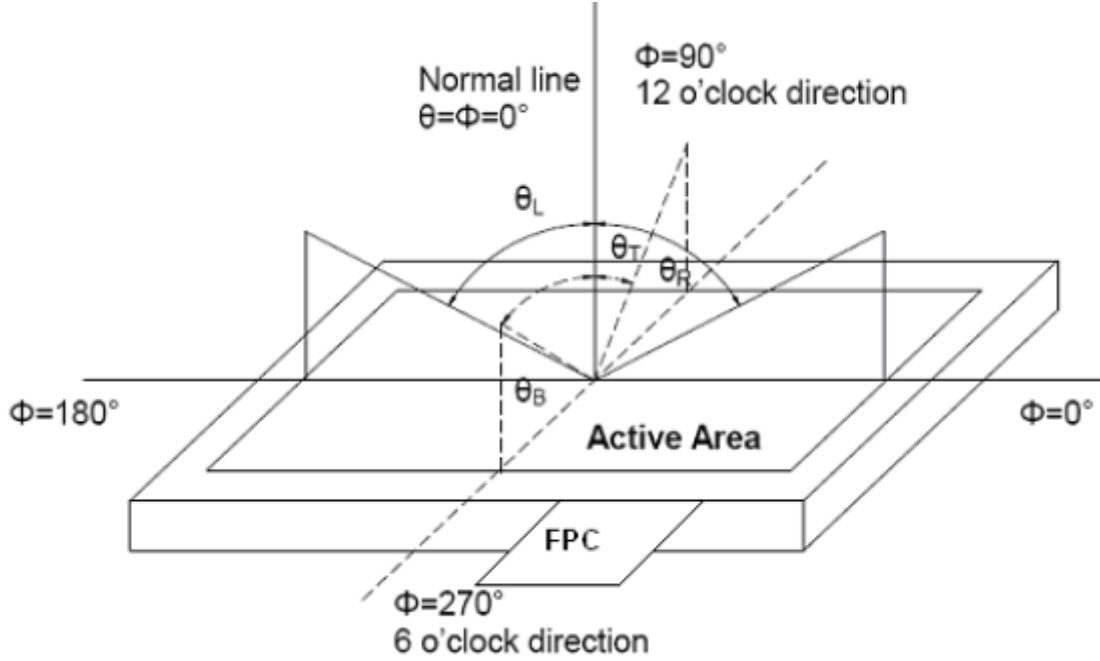

Figure 4-1 – Viewing Angle definition



Figure 4-2 – Module orientation for viewing angle

5 Board Schematics

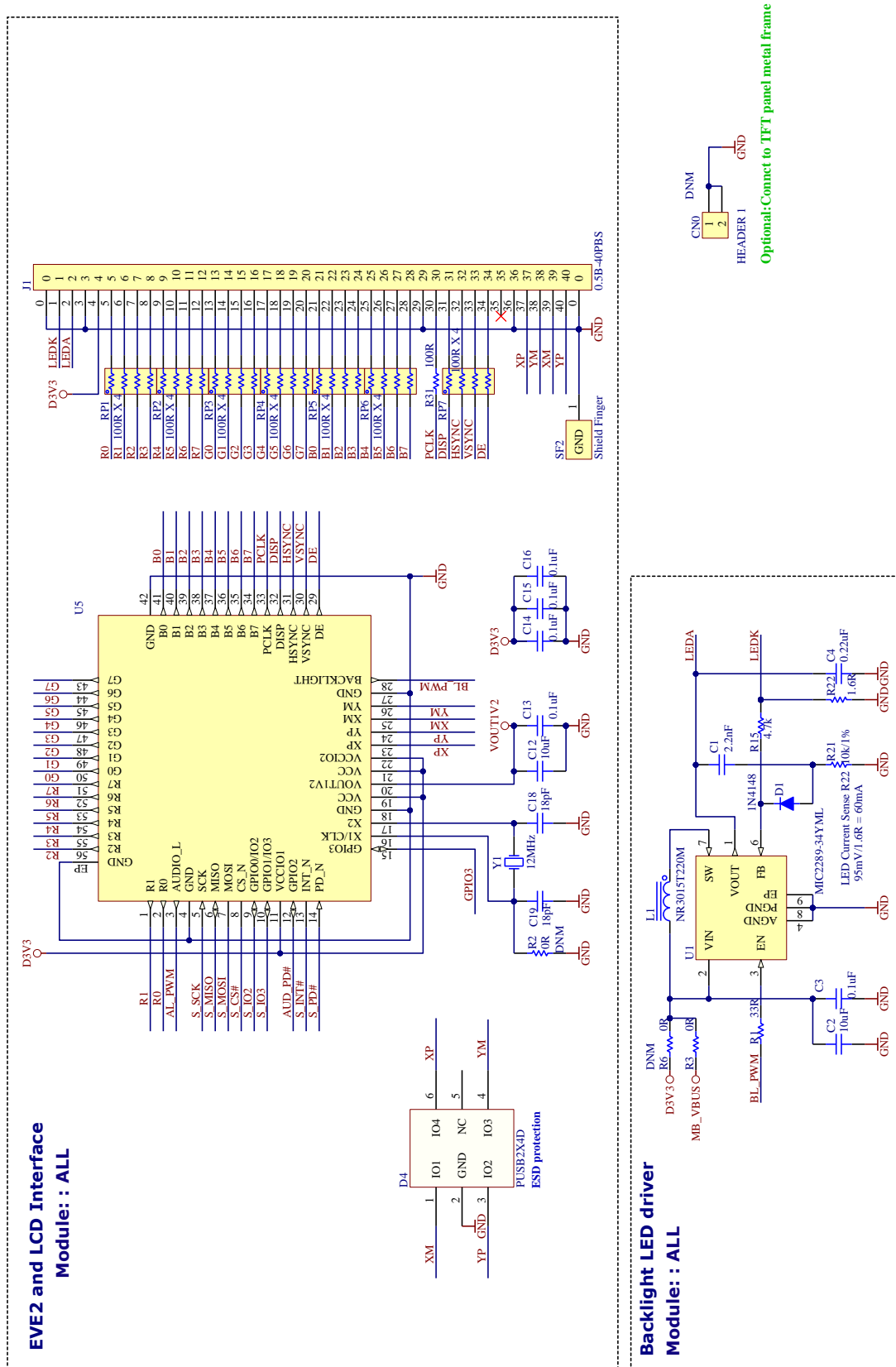

Figure 5-1 – Board Schematic (page 1)

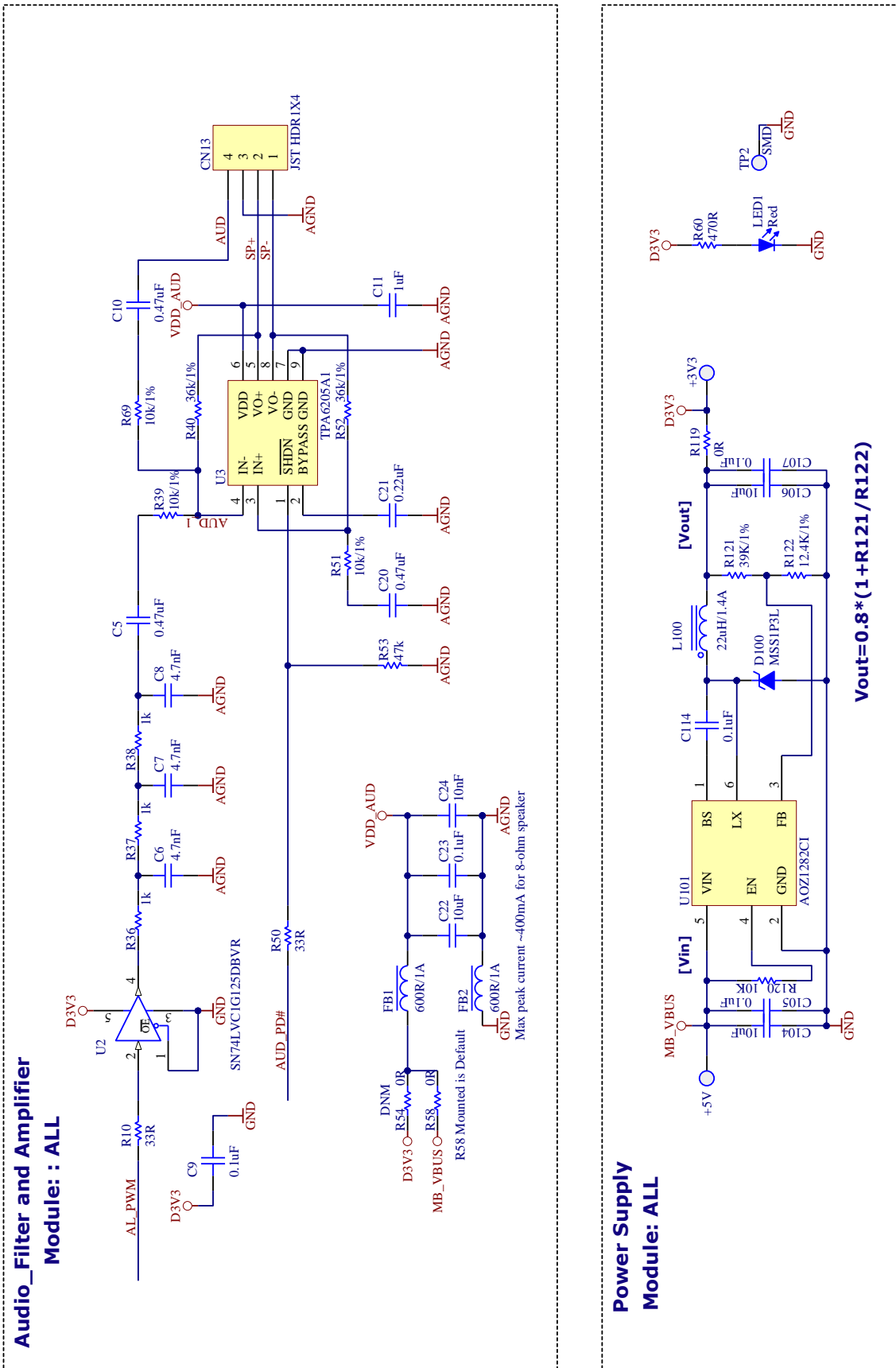

Figure 5-2 – Board Schematic (page 2)

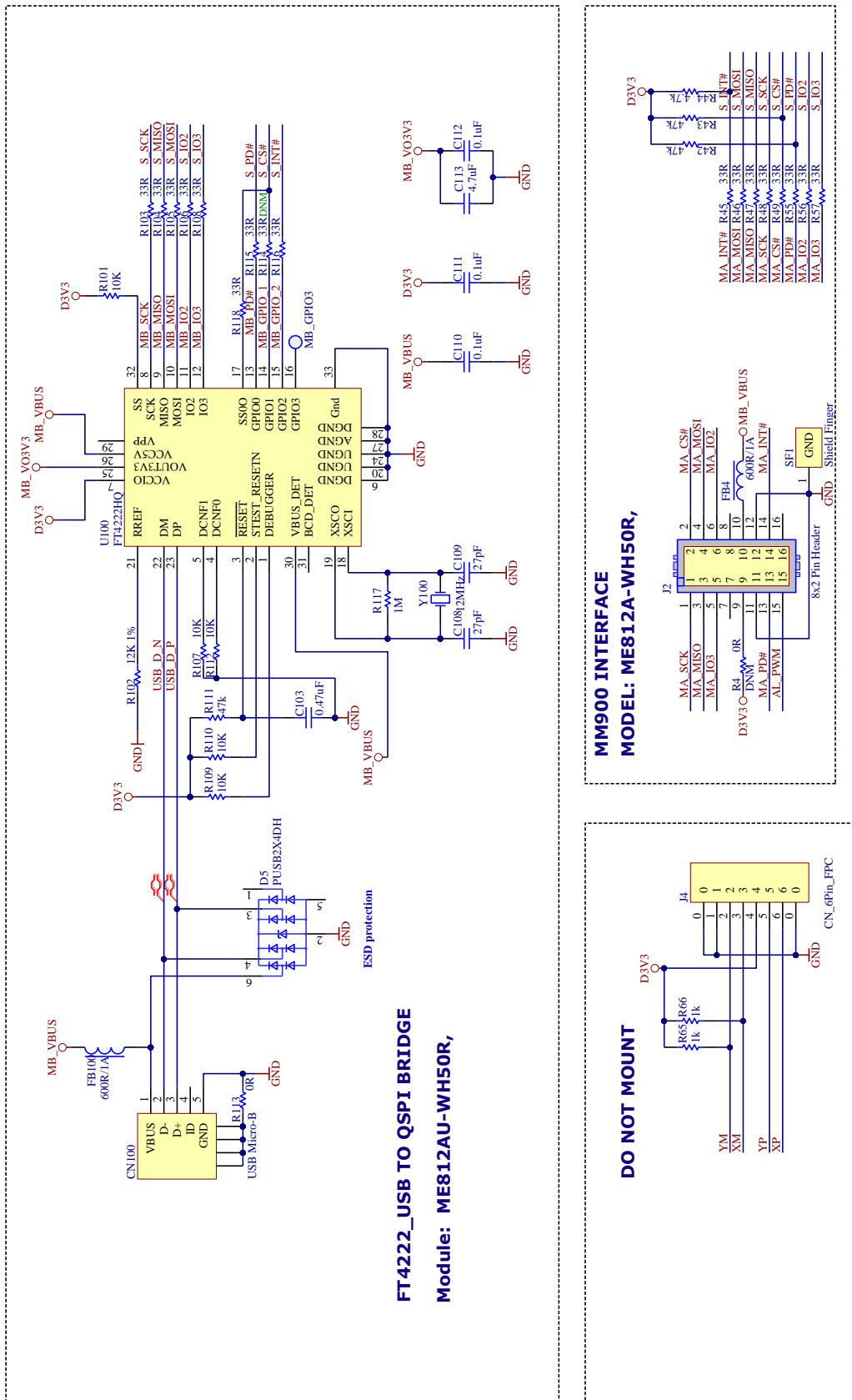

Figure 5-3 – Board Schematic (page 3)

6 Mechanical Dimensions

6.1 Module Dimensions

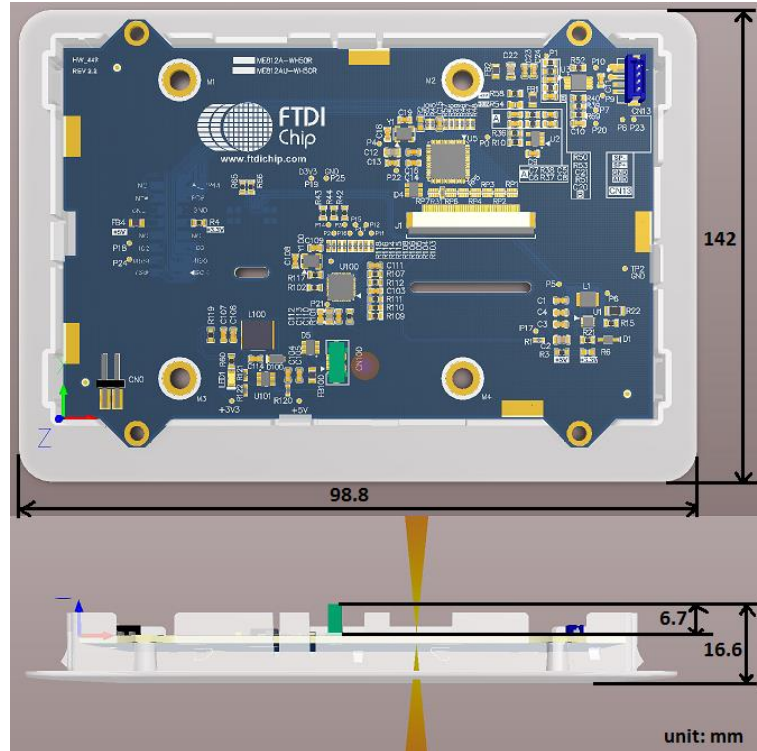

Figure 6-1 – Module Dimensions

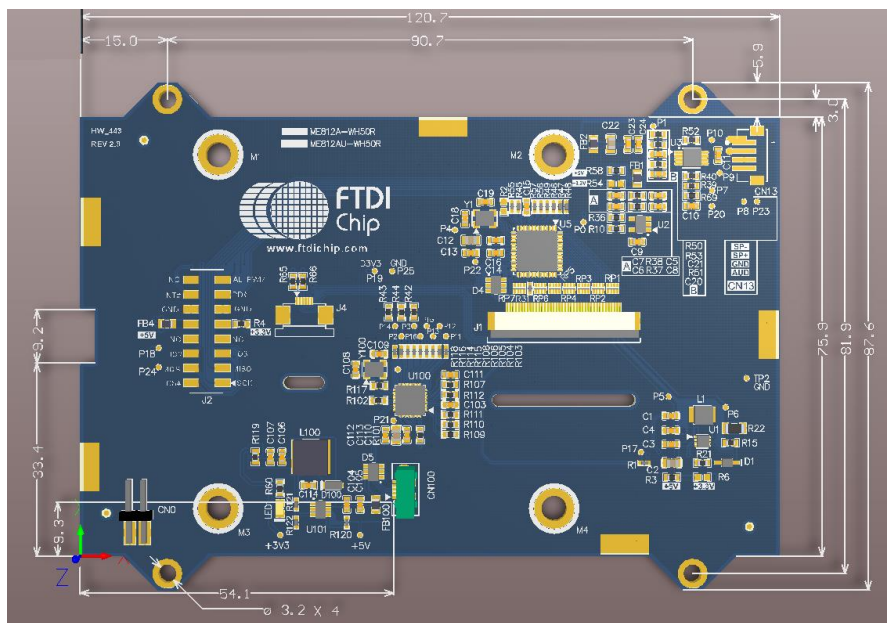

Figure 6-2 – PCB Dimensions

7 Getting Started

7.1 Hardware Setup

Error! Reference source not found. shows the ME812AU-WH50R module connected to the PC USB host port or self-powered hub port through a USB cable (suggest FTDI accessory VA-FC-1M-BKW or VA-FC-1M-BLW). The 1W speaker is optional (suggest Bridgetek accessory CleO-SPK1). Note that if the 1W speaker is used, the USB power shall be able to supply at least 900mA current.

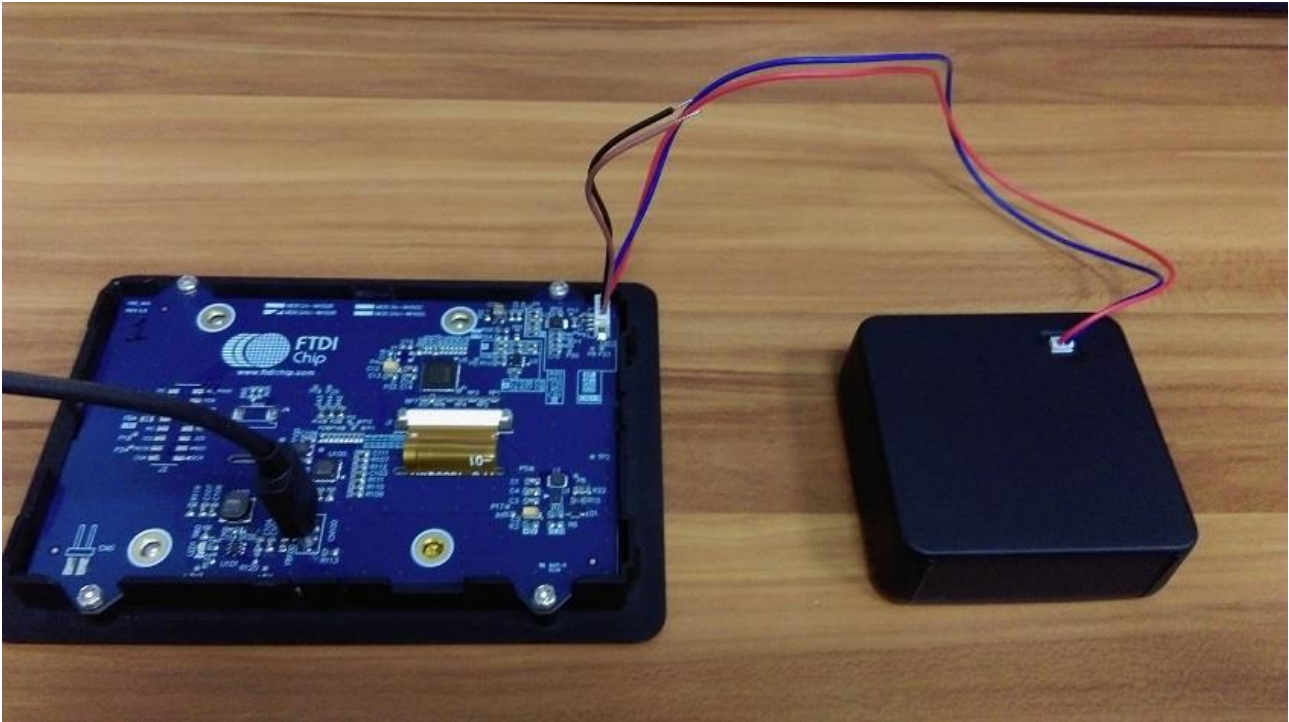

Figure 7-1 – ME812AU-WH50R connects to USB host

7.2 Software Setup

- Download the sample application for ME812AU-WH50R from the Bridgetek website at <http://brtchip.com/eve-projects/>
- Install the FT4222H driver on a Windows PC. (downloadable at <http://www.ftdichip.com/Products/ICs/FT4222H.html>)
- Launch the demo application from the PC.

The sample applications will demonstrate display, touch and audio functions of the ME812AU-WH50R module. Refer to [AN 418 ME81XAU SampleApp PC Introduction](#) for more details.

8 Contact Information

Head Quarters – Singapore

Bridgetek Pte Ltd
178 Paya Lebar Road, #07-03
Singapore 409030
Tel: +65 6547 4827
Fax: +65 6841 6071

E-mail (Sales) sales.apac@brtchip.com
E-mail (Support) support.apac@brtchip.com

Branch Office – Taipei, Taiwan

Bridgetek Pte Ltd, Taiwan Branch
2 Floor, No. 516, Sec. 1, Nei Hu Road, Nei Hu
District
Taipei 114
Taiwan, R.O.C.
Tel: +886 (2) 8797 5691
Fax: +886 (2) 8751 9737

E-mail (Sales) sales.apac@brtchip.com
E-mail (Support) support.apac@brtchip.com

Branch Office - Glasgow, United Kingdom

Bridgetek Pte. Ltd.
Unit 1, 2 Seaward Place, Centurion Business Park
Glasgow G41 1HH
United Kingdom
Tel: +44 (0) 141 429 2777
Fax: +44 (0) 141 429 2758

E-mail (Sales) sales.emea@brtchip.com
E-mail (Support) support.emea@brtchip.com

Branch Office – Vietnam

Bridgetek VietNam Company Limited
Lutaco Tower Building, 5th Floor, 173A Nguyen
Van Troi,
Ward 11, Phu Nhuan District,
Ho Chi Minh City, Vietnam
Tel : 08 38453222
Fax : 08 38455222

E-mail (Sales) sales.apac@brtchip.com
E-mail (Support) support.apac@brtchip.com

Web Site

<http://brtchip.com/>

Distributor and Sales Representatives

Please visit the Sales Network page of the [Bridgetek Web site](http://brtchip.com/) for the contact details of our distributor(s) and sales representative(s) in your country.

System and equipment manufacturers and designers are responsible to ensure that their systems, and any Bridgetek Pte Limited (BRTChip) devices incorporated in their systems, meet all applicable safety, regulatory and system-level performance requirements. All application-related information in this document (including application descriptions, suggested Bridgetek devices and other materials) is provided for reference only. While Bridgetek has taken care to assure it is accurate, this information is subject to customer confirmation, and Bridgetek disclaims all liability for system designs and for any applications assistance provided by Bridgetek. Use of Bridgetek devices in life support and/or safety applications is entirely at the user's risk, and the user agrees to defend, indemnify and hold harmless Bridgetek from any and all damages, claims, suits or expense resulting from such use. This document is subject to change without notice. No freedom to use patents or other intellectual property rights is implied by the publication of this document. Neither the whole nor any part of the information contained in, or the product described in this document, may be adapted or reproduced in any material or electronic form without the prior written consent of the copyright holder. Bridgetek Pte Limited, 178 Paya Lebar Road, #07-03, Singapore 409030. Singapore Registered Company Number: 201542387H.

Appendix A - References

Document References

[DS_FT81x datasheet](#)

[FT81x Series Programmer Guide](#)

[FT4222H Datasheet](#)

[FT81x Sample Applications](#)

Acronyms and Abbreviations

Terms	Description
EVE	Embedded Video Engine
IC	Integrated Circuit
LCD	Liquid Crystal Display
LED	Light Emitting Diode
MCU	Micro-Controller Unit
PC	Personal Computer
PCB	Printed Circuit Board
PWM	Pulse Width Modulation
SPI	Serial Peripheral Interface
TFT	Thin Film Transistor
TP	Touch Panel
USB	Universal Serial Bus

Appendix B - List of Figures and Tables

List of Figures

Figure 3-1 – ME812AU-WH50R board bottom view	4
Figure 4-1 – Viewing Angle definition	8
Figure 4-2 – Module orientation for viewing angle	8
Figure 5-1 – Board Schematic (page 1)	9
Figure 5-2 – Board Schematic (page 2)	10
Figure 5-3 – Board Schematic (page 3)	11
Figure 6-1 – Module Dimensions	12
Figure 6-2 – PCB Dimensions	12
Figure 6-2 – Bezel dimensions.....	13
Figure 7-1 – ME812AU-WH50R connects to USB host	14

List of Tables

Table 2-1 – Ordering information	2
Table 3-1 – CN100 pin description	4
Table 3-2 – CN13 pin description	5
Table 4-1 - Operating Voltage and Current.....	6
Table 4-2 - LCD and Touch Information	6
Table 4-3 - 5.0" TFT Optical specification	7

Appendix C – Revision History

Document Title: ME812AU-WH50R Module Datasheet
Document Reference No.: BRT_000105
Clearance No.: BRT#063
Product Page: <http://brtchip.com/eve-2-development-modules-landing/>
Document Feedback: [Send Feedback](#)

Revision	Changes	Date
1.0	Initial Release	2017-02-21



Компания «ЭлектроПласт» предлагает заключение долгосрочных отношений при поставках импортных электронных компонентов на взаимовыгодных условиях!

Наши преимущества:

- Оперативные поставки широкого спектра электронных компонентов отечественного и импортного производства напрямую от производителей и с крупнейших мировых складов;
- Поставка более 17-ти миллионов наименований электронных компонентов;
- Поставка сложных, дефицитных, либо снятых с производства позиций;
- Оперативные сроки поставки под заказ (от 5 рабочих дней);
- Экспресс доставка в любую точку России;
- Техническая поддержка проекта, помощь в подборе аналогов, поставка прототипов;
- Система менеджмента качества сертифицирована по Международному стандарту ISO 9001;
- Лицензия ФСБ на осуществление работ с использованием сведений, составляющих государственную тайну;
- Поставка специализированных компонентов (Xilinx, Altera, Analog Devices, Intersil, Interpoint, Microsemi, Aeroflex, Peregrine, Syfer, Eurofarad, Texas Instrument, Miteq, Cobham, E2V, MA-COM, Hittite, Mini-Circuits, General Dynamics и др.);

Помимо этого, одним из направлений компании «ЭлектроПласт» является направление «Источники питания». Мы предлагаем Вам помощь Конструкторского отдела:

- Подбор оптимального решения, техническое обоснование при выборе компонента;
- Подбор аналогов;
- Консультации по применению компонента;
- Поставка образцов и прототипов;
- Техническая поддержка проекта;
- Защита от снятия компонента с производства.



Как с нами связаться

Телефон: 8 (812) 309 58 32 (многоканальный)

Факс: 8 (812) 320-02-42

Электронная почта: org@eplast1.ru

Адрес: 198099, г. Санкт-Петербург, ул. Калинина, дом 2, корпус 4, литера А.