

NPS40-M Series

60 Watts

Total Power: 40 - 60 Watts
Input Voltage: 90 - 264 VAC
127 - 300 VDC
of Outputs: Single

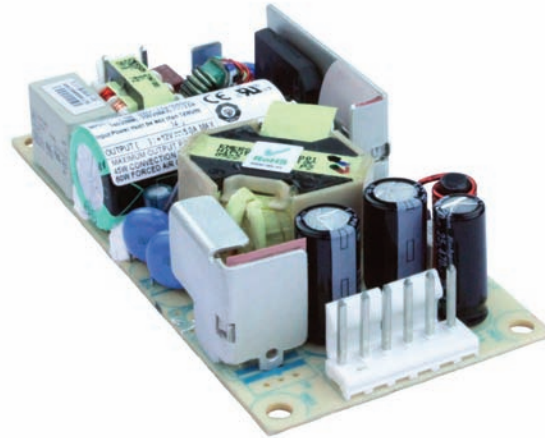

Special Features

- Medical and ITE Safety Approvals
- Universal input
- Less than 1U high
- 2" x 4" footprint
- Remote sense
- Overload and short circuit protection
- Adjustable output voltage
- High efficiency
- High MTBF
- Built in EMI filter (CISPR 22 Class B)
- International Efficiency Level V, Energy Star 2.0 & CeC compliant (except NPS42-M)
- Less than 300 mW no-load power consumption
- 0° C to +80° C operation
- Input power < 74 watts
- Complies with EN61000-3-2
- UL Class I approved
- LPX50 enclosure kit available
- Dual AC fuses

Safety

- **TUV:** 60950, 60601-1
- **UL:** 60950, 60601-1
- **CSA:** 60950, 60601-1
- **NEMKO:** 60950, 60601-1
- **CB:** Certificate and report
- **CE:** Mark (LVD)
- **CQC:** Mark

Electrical Specifications

Input	
Input range:	90 - 264 VAC (wide range) 127-300 Vdc
Frequency:	47-440 Hz
Inrush current:	< 50 A peak @ 230 VAC, cold start @ 25° C
Input power:	< 74 Watts
Efficiency:	87% average (as per Energy Star 2.0 standard) (NPS42-M, 80%)
EMI/RFI:	FCC Class B conducted; CISPR 22 Class B conducted; EN55022 Class B conducted, VDE0878PT3 Class B conducted
Safety ground leakage current:	275uA @ 50/60 Hz; 264 VAC input
Output	
Maximum power:	45W for convection (NPS42-M, 40 W). 60 W with 200LFM forced air (NPS42-M, 55 W)
Adjustment range:	±20% minimum
Hold-up time:	10/20 ms 115/230 VAC input line
Overload protection:	Short circuit protection on all outputs. Case overload protected @ 110-160% of normal rating
Overvoltage protection:	30-50% above nominal output
Remote sense:	Compensated for 0.5 V lead drop max. Will operate without remote sense connected. Reverse connection protected.

Environmental Specifications

Operating temperature:	0° to 50 °C ambient derate each output as 2.5% per degree from 50° to 80 °C. -20 °C start up
Storage temperature:	-45 °C to +85 °C
Electromagnetic susceptibility:	Designed to meet EN61000-4; -2, -3, -4, -5, -6, -8, -11 Level 3
Humidity:	Operating; non-condensing 10% to 90% RH
Vibration:	IEC68-2-6 to the levels of IEC721-3-2
MTBF demonstrated:	> 550,000 hours at full load and 25 °C ambient conditions

Mechanical Drawing

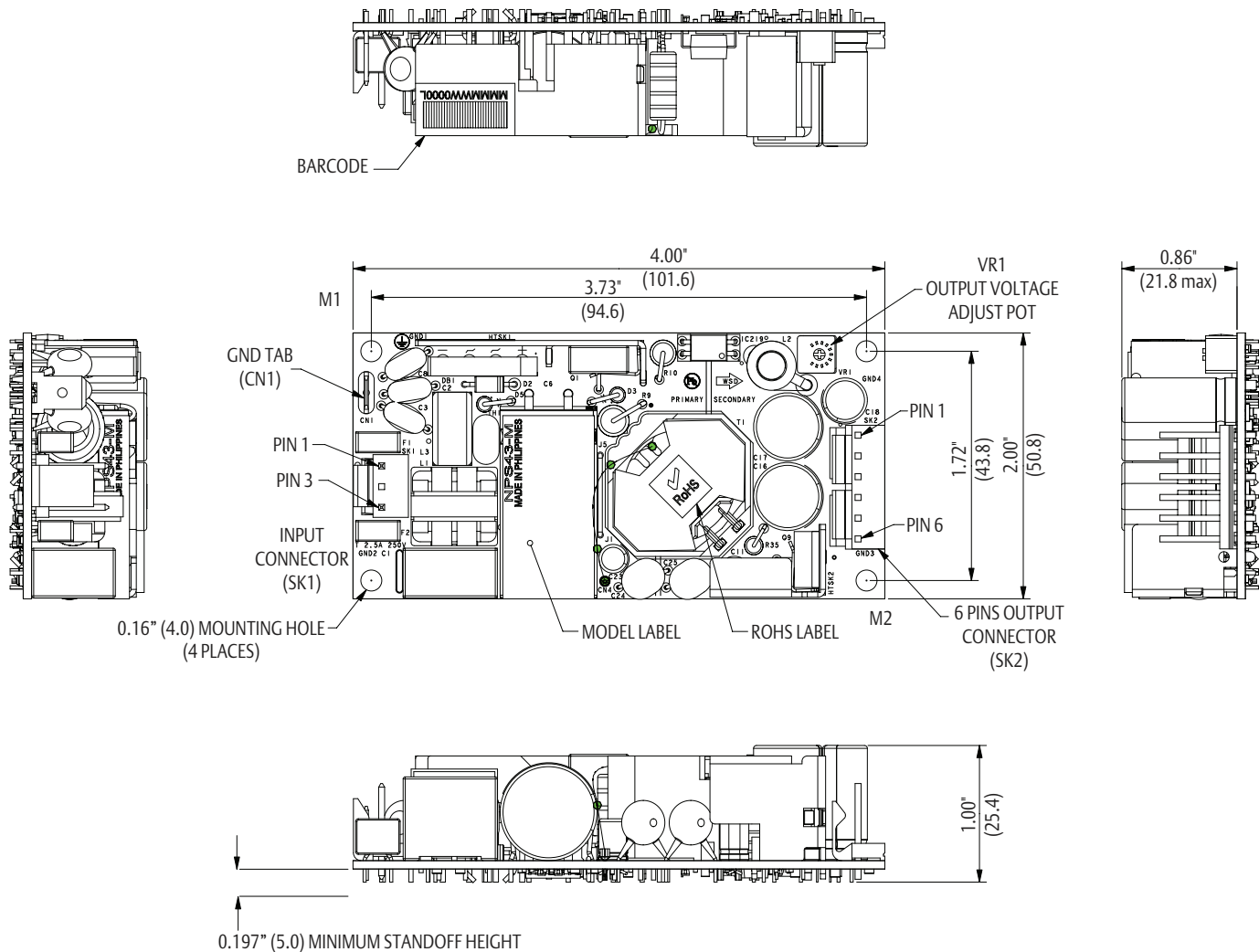

Ordering Information

Model Number	Output Voltage	Minimum Load	Maximum Load with Convection Cooling	Maximum Load with 30CFM Forced Air	Peak Load ¹	Regulation ²	Ripple P/P (PARD) ³
NPS42-M	5 V	0 A	8 A	11 A	13 A	±2%	50 mV
NPS43-M	12 V	0 A	3.75 A	5 A	5.5 A	±2%	120 mV
NPS44-M	15 V	0 A	3 A	4 A	4.4 A	±2%	150 mV
NPS45-M	24 V	0 A	1.9 A	2.5 A	2.75 A	±2%	240 mV
NPS48-M	48 V	0 A	0.94 A	1.25 A	1.38 A	±2%	480 mV

1. Peak current lasting < 15 seconds with a maximum 10% duty cycle.
2. At 25 °C including initial tolerance, line voltage, load currents and output voltages adjusted to factory settings.
3. Peak-to-peak with 20 MHz bandwidth and 10 µF (tantalum capacitor) in parallel with a 0.1 µF capacitor at rated line voltage and load ranges.

Pin Assignments

Connector	NPS42-M	NPS43-M	NPS44-M	NPS45-M	NPS48-M
SK1-1	Line	Line	Line	Line	Line
SK1-3	Neutral	Neutral	Neutral	Neutral	Neutral
SK2-1	+5 V	+12 V	+15 V	+24 V	+48 V
SK2-2	+5 V	+12 V	+15 V	+24 V	+48 V
SK2-3	Common	Common	Common	Common	Common
SK2-4	Common	Common	Common	Common	Common
SK2-5	-Sense	-Sense	-Sense	-Sense	-Sense
SK2-6	+Sense	+Sense	+Sense	+Sense	+Sense

Mating Connectors

AC Input: Molex 09-50-8031 (USA)
09-91-0300 (UK)
PINS: 08-52-0113

DC Outputs: Molex 09-50-8061 (USA)
09-91-0600 (UK)
PINS: 08-52-0113

Emerson Network Power Connector Kit #70-841-006, includes all of the above

Notes:

1. Specifications subject to change without notice.
2. All dimensions in inches (mm), tolerance is ±0.02" (±0.5mm)
3. Mounting holes M1 and M2 should be grounded for EMI purposes.
4. Mounting hole M1 is safety ground connection.
5. Specifications are for convection rating at factory settings at 115 VAC input, 25 °C unless otherwise stated.
6. Warranty: 2 year
7. Weight: 0.41lbs/0.18kg

Americas

5810 Van Allen Way
Carlsbad, CA 92008
USA
Telephone: +1 760 930 4600
Facsimile: +1 760 930 0698

Europe (UK)

Waterfront Business Park
Merry Hill, Dudley
West Midlands, DY5 1LX
United Kingdom
Telephone: +44 (0) 1384 842 211
Facsimile: +44 (0) 1384 843 355

Asia (HK)

14/F, Lu Plaza
2 Wing Yip Street
Kwun Tong, Kowloon
Hong Kong
Telephone: +852 2176 3333
Facsimile: +852 2176 3888

For global contact, visit:

www.PowerConversion.com

techsupport.embeddedpower@emerson.com

While every precaution has been taken to ensure accuracy and completeness in this literature, Emerson Network Power assumes no responsibility, and disclaims all liability for damages resulting from use of this information or for any errors or omissions.

Emerson Network Power.
The global leader in enabling
business-critical continuity.

- AC Power
- Connectivity
- DC Power
- Embedded Computing
- **Embedded Power**
- Monitoring
- Outside Plant
- Power Switching & Controls
- Precision Cooling
- Racks & Integrated Cabinets
- Services
- Surge Protection

EmersonNetworkPower.com

Emerson Network Power and the Emerson Network Power logo are trademarks and service marks of Emerson Electric Co. ©2009 Emerson Electric Co.



Компания «ЭлектроПласт» предлагает заключение долгосрочных отношений при поставках импортных электронных компонентов на взаимовыгодных условиях!

Наши преимущества:

- Оперативные поставки широкого спектра электронных компонентов отечественного и импортного производства напрямую от производителей и с крупнейших мировых складов;
- Поставка более 17-ти миллионов наименований электронных компонентов;
- Поставка сложных, дефицитных, либо снятых с производства позиций;
- Оперативные сроки поставки под заказ (от 5 рабочих дней);
- Экспресс доставка в любую точку России;
- Техническая поддержка проекта, помощь в подборе аналогов, поставка прототипов;
- Система менеджмента качества сертифицирована по Международному стандарту ISO 9001;
- Лицензия ФСБ на осуществление работ с использованием сведений, составляющих государственную тайну;
- Поставка специализированных компонентов (Xilinx, Altera, Analog Devices, Intersil, Interpoint, Microsemi, Aeroflex, Peregrine, Syfer, Eurofarad, Texas Instrument, Miteq, Cobham, E2V, MA-COM, Hittite, Mini-Circuits, General Dynamics и др.);

Помимо этого, одним из направлений компании «ЭлектроПласт» является направление «Источники питания». Мы предлагаем Вам помощь Конструкторского отдела:

- Подбор оптимального решения, техническое обоснование при выборе компонента;
- Подбор аналогов;
- Консультации по применению компонента;
- Поставка образцов и прототипов;
- Техническая поддержка проекта;
- Защита от снятия компонента с производства.



Как с нами связаться

Телефон: 8 (812) 309 58 32 (многоканальный)

Факс: 8 (812) 320-02-42

Электронная почта: org@eplast1.ru

Адрес: 198099, г. Санкт-Петербург, ул. Калинина, дом 2, корпус 4, литера А.