

LEAD STYLES

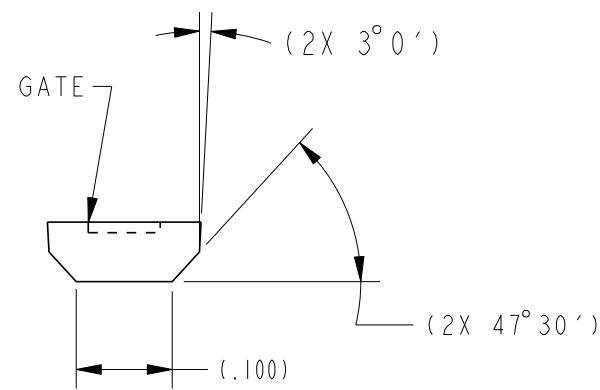

ALL EXCEPT "L" LEAD STYLES

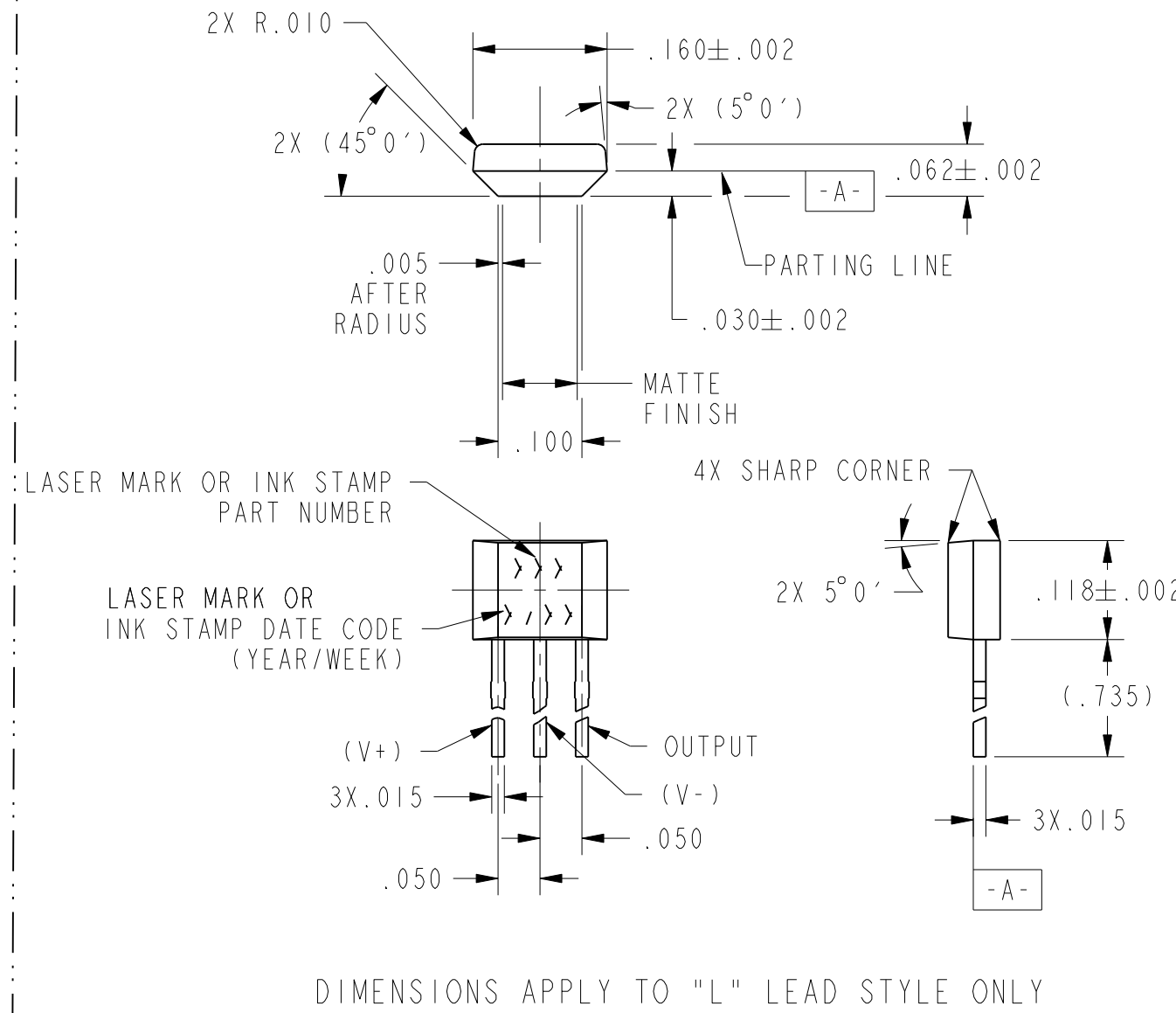

DIMENSIONS APPLY TO "L" LEAD STYLE ONLY

LASER MARK OR INK STAMP BRAND SYMBOL
.039 HIGH CHARACTERS

LASER MARK OR INK STAMP DATE CODE
(YEAR, WEEK) .039 HIGH CHARACTERS (3 DIGITS)

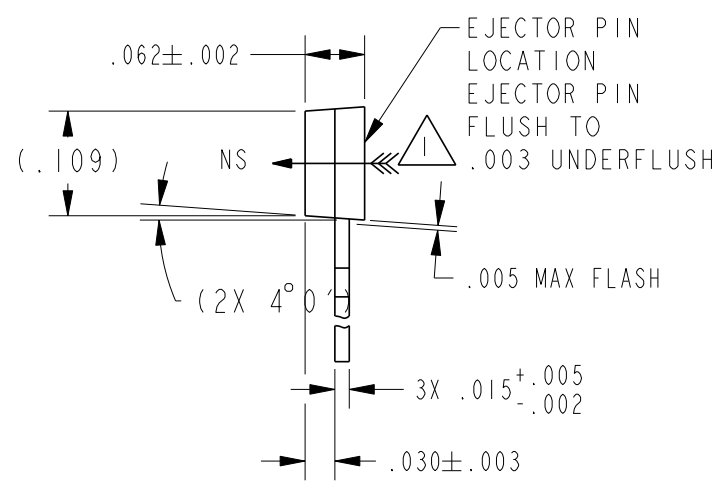
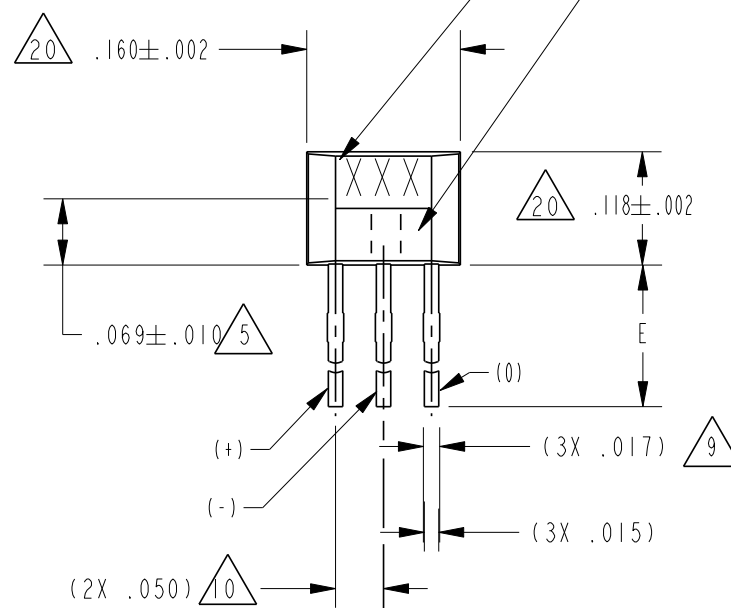

LEAD STYLES "STD", "R", "RP"

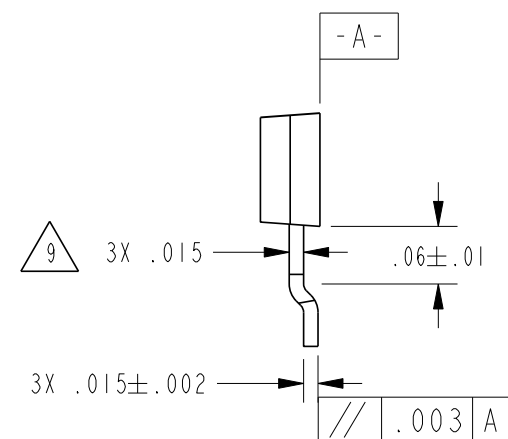
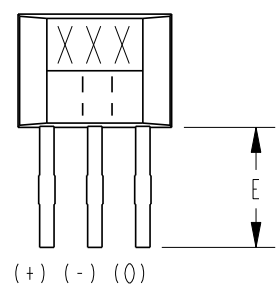

LEAD STYLES "S" & "SP"

NOTES

- 1 THE MAGNETIC FLUX USED TO OPERATE THE SWITCH MUST BE IN THE DIRECTION AND LOCATION SHOWN (THIS ASSUMES THE CONVENTION THAT THE DIRECTION OF THE EXTERNAL FLUX OF A MAGNET IS FROM THE NORTH TO THE SOUTH POLE OF THE MAGNET)
- 2 THE MAGNETIC FIELD STRENGTH (GAUSS) REQUIRED TO CAUSE THE SWITCH TO CHANGE STATE (OPERATE AND RELEASE) WILL BE AS TABULATED. TO TEST THE SWITCH AGAINST THE SPECIFIED LIMITS, THE SWITCH MUST BE PLACED IN A UNIFORM MAGNETIC FIELD
- 3 ABSOLUTE MAXIMUM RATINGS ARE THE EXTREME LIMITS THE DEVICE WILL MOMENTARILY WITHSTAND WITHOUT DAMAGE TO THE DEVICE. ELECTRICAL AND MAGNETIC CHARACTERISTICS ARE NOT GUARANTEED IF THE RATED VOLTAGE AND/OR CURRENTS ARE EXCEEDED NOR WILL THE DEVICE NECESSARILY OPERATE AT ABSOLUTE MAXIMUM RATINGS
- 4 TEST CONDITIONS: $V_{cc}=12V$, $R_2=1.6K$ OHMS, $C_2=20pF$
- 5 APPROXIMATE HALL ELEMENT LOCATION
- 6 LEADS MUST BE ADEQUATELY SUPPORTED DURING ANY FORMING/SHEERING OPERATION TO ASSURE THAT THE LEADS ARE NOT STRESSED WITHIN THE PLASTIC
- 7 PCB WAVE SOLDERING GUIDELINES ARE AS FOLLOWS:
250°C PEAK FOR 10 S MAX OR 260°C PEAK FOR 5S MAX
SOLDERING TIME
- 8 $V_{cc}=12V$, $R_L=1.6K$, $C_L=20pF$
- 9 BURRS ARE ALLOWED ONLY IF FULL LENGTH OF LEADS WILL PASS THROUGH $\phi .023$ HOLE. LEAD REFERENCE DIMENSIONS DO NOT INCLUDE SOLDER THICKNESS
- 10 DIMENSION REFERS TO THE LOCATION OF LEAD CENTERLINES AS THEY EXIT THE PLASTIC PACKAGE
- 11 TYPICAL DIMENSIONS NOT SHOWN IN LEAD STYLE "S" AND "SP"
- 12 SOME COMBINATIONS OF BASIC LISTING AND PACKING OPTIONS ARE NOT AVAILABLE
- 13 TAPE AND AMMOPACK PER EIA-468-A-1990
- 14 POCKET TAPE AND REEL PER EIA-481-A-1986
- 15 $V_{cc}=30V$, $I_{sink}=20mA$, $-40^{\circ}C < T < 150^{\circ}C$, B>MAX OP GAUSS FOR SPECIFIC LISTING
- 16 $V_{cc}=3.8V$, $I_{sink}=20mA$, B>MAX OP GAUSS FOR SPECIFIC LISTING
- 17 $V_{out}=30V$, $V_{cc}=24V$, B<MIN RELEASE GAUSS FOR SPECIFIC LISTING
- 18 AMMOPACK STYLE "T2" AND "T3". 24 SWITCHES BETWEEN FOLDS, SKIP 1 SPACE AT FOLD. MAY BE REFERRED TO AS "FAN FOLD"
- 19 LEAD STRAIGHTNESS MAY BE DETERIORATED ON SOME UNITS BY BULK PACKAGING. APPLICATIONS HAVING A CRITICAL LEAD STRAIGHTNESS REQUIREMENT SHOULD USE A TAPE PACKAGING OPTION
- 20 MOLDED PART DIMENSIONS DO NOT INCLUDE FLASH. FLASH IS LIMITED TO .005 MAX
- 21 THESE HALL EFFECT SENSORS MAY HAVE AN INITIAL OUTPUT IN EITHER THE ON OR OFF STATE IF POWERED UP WITH AN APPLIED MAGNETIC FIELD IN THE DIFFERENTIAL ZONE (APPLIED MAGNETIC FIELD $> B_{rp}$ AND $< B_{op}$). MICRO SWITCH RECOMMENDS THAT THE APPLICATION CIRCUIT DESIGNER ALLOW 10 MICROSECONDS AFTER SUPPLY VOLTAGE HAS REACHED 5 VOLTS FOR THE OUTPUT VOLTAGE TO STABILIZE



THIRD ANGLE PROJECTION			
SCALE 5 : 1			
DO NOT SCALE PRINT			
TOLERANCES APPLY TO DESIGN UNITS. CONVERSIONS ARE ONLY FOR REFERENCE. UNLESS NOTED, TOLERANCES ARE :			
DIM	TOL	DIM	TOL
NO PLACES	X	1/2, .04	X.X
ONE PLACE	X.X	0.47, .016	X.XX
TWO PLACES	X.XX	0.157, .006	X.XXX
THREE PLACES	X.XXX		X.XXXX
ANGLES			
SI METRIC		US CUSTOMARY	
DESIGN UNITS	<input type="checkbox"/>	<input checked="" type="checkbox"/>	
WEIGHT			

THIS DRAWING COVERS A PROPRIETARY ITEM AND IS THE PROPERTY OF MICRO SWITCH, A DIVISION OF HONEYWELL. THIS DRAWING IS NOT TO BE COPIED OR USED WITHOUT THE APPROVAL OF MICRO SWITCH.

MICRO SWITCH
a Honeywell Division

SOLID STATE SENSOR

SS400 SERIES CHART 1

ANSI Y14.5M-1982 APPLIES

FED. MFG. CODE 91929

SS400 SERIES CHART 1
 DRAWING NUMBER
 ISSUE 16
 REVISIONS
 E 0034535
 PPS
 26 OCT 07
 CHECK
 SAV 26 MAR 02
 CHECK
 GRT 26 MAR 02
 CHECK
 PTC/CAD 3D
 DRAWN
 RELEASE NO. PR-21345
 PAGE 1 OF 4
 REPLACES

SOLID STATE SENSOR

SS400 SERIES CHART 1

CATALOG LISTING

THIS DRAWING COVERS A PROPRIETARY ITEM AND IS THE PROPERTY OF MICRO SWITCH. A DIVISION OF HONEYWELL. THIS DRAWING IS NOT TO BE COPIED OR USED WITHOUT THE APPROVAL OF MICRO SWITCH

CATALOGING SYSTEM $\triangle 12$

CATALOG LISTING
SS400 SERIES CHART 1

ISSUE
16

REVISIONS
E 0034535
PRS
26 OCT 07

PTC/CAD
DRAWN
KED 14 JAN 99

RELEASE NO. PR-21345
PAGE 2 OF 4
CHECK
14 JAN 99
CHECK
14 JAN 99

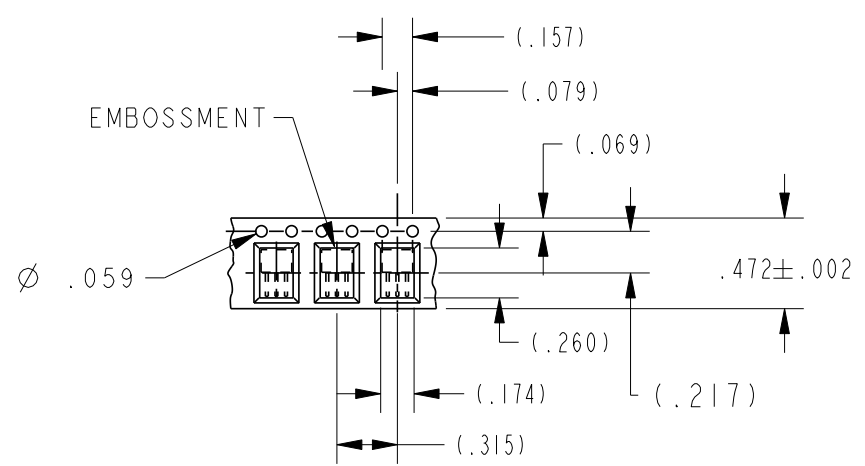
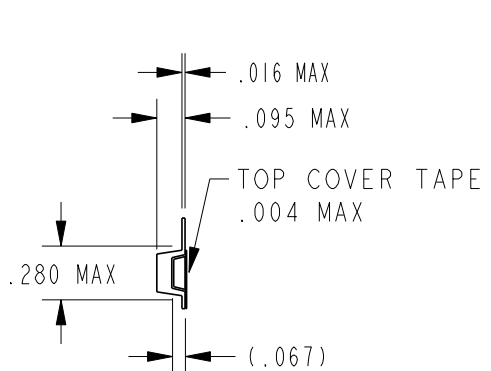
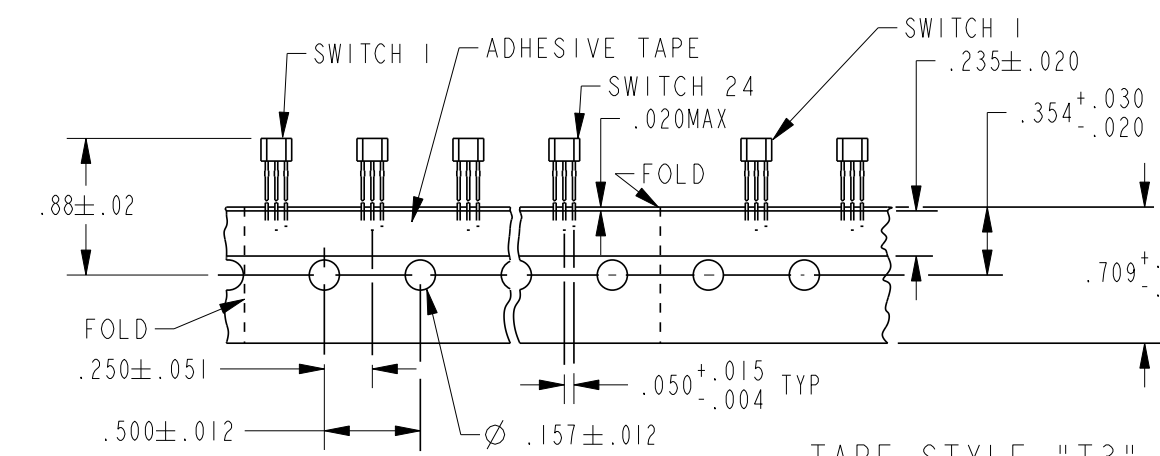
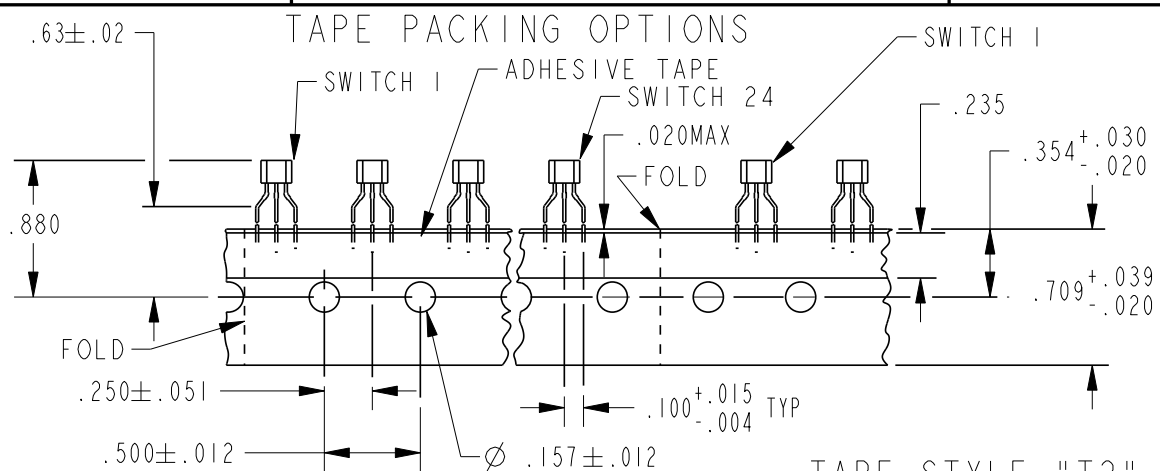

PREFIX SUFFIX
BASIC CATALOG LISTING: PACKAGE STYLE, MAGNETIC TYPE, ELECTRICAL/MAGNETIC SPECS
LEAD & PACKAGING OPTIONS: BULK, TAPE & REEL, POCKET TAPE & REEL

CHARACTERS IN THESE POSITIONS OF THE LISTING ARE BRANDED ON THE PRODUCT

SS441A1

SS4=PACKAGE STYLE
MAGNETIC TYPE
1=BIPOLAR
4=UNIPOLAR
6=LATCH
9=LINEAR
RELATIVE GAUSS OPERATING RANGE (0-9, 9=HIGH GAUSS)#
ELECTRICAL/MAGNETIC OPTIONS (A-K, & U-Z)
A=STANDARD
B-K & U-Z=SPECIALS
SPECIAL FEATURE (BLANK, 1-9)
BLANK=STANDARD
1-9=SPECIALS

DESCRIPTION	NOMINAL LEAD SPACING	NOMINAL "E" DIM LENGTH ±.015	PARTS PER CONTAINER
STANDARD, BULK PACK $\triangle 19$.050	.590	1000/BAG
-T 2 TAPE, AMMOPACK	.100	.590	5000/BOX
-T 3 TAPE, AMMOPACK	.050	.590	5000/BOX
-S SURFACE MOUNT, BULK PACK	.050	.125	1000/BAG
-S P SURFACE MOUNT, POCKET TAPE	.050	.125	1000/REEL
-R REDUCED LENGTH, BULK PACK	.050	.130	1000/BAG
-R P REDUCED LENGTH, POCKET TAPE	.050	.130	1000/REEL
-L LONG LEADS, BULK PACK	.050	.735	1000/BAG

TAPE STYLE "SP" & "RP" $\triangle 14$

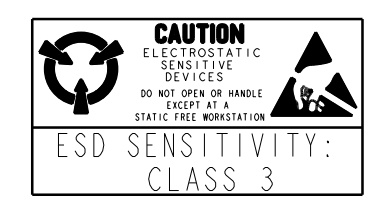
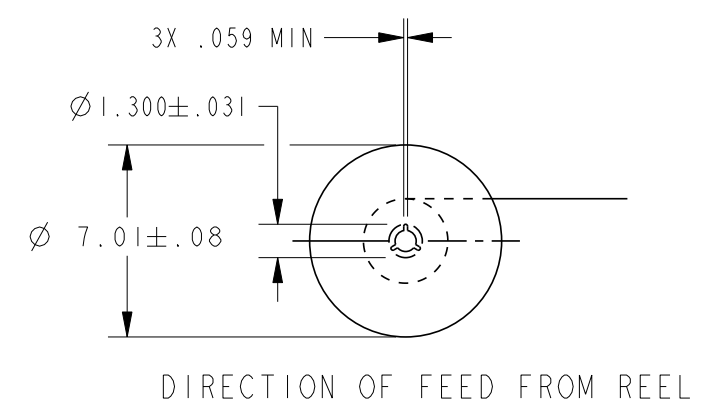

THIRD ANGLE PROJECTION	
SCALE	NONE
DO NOT SCALE PRINT	
UNLESS OTHERWISE SPECIFIED TOLERANCES ARE	
ONE PLACE	(.0) ±.030
TWO PLACE	(.00) ±.015
THREE PLACE	(.000) ±.005
ANGLES	±
WEIGHT	

CATALOG LISTING
SS400 SERIES CHART 1
 PAGE 3 OF 4
 RELEASE NO. PR-21345
 REPLACES -
 ISSUE 16
 CHECK
 REVISIONS
 E 0034535
 PRS 26 OCT 07
 CHECK
 14 JAN 99
 JAF
 CHECK
 14 JAN 99
 DRAWN
 PTC/CAD 3D
 KED

TABLE 1 - MAGNETIC AND ELECTRICAL SPECIFICATIONS $\triangle 2 \triangle 21$

	-40°C	0°C	25°C	85°C	125°C	150°C
MIN OPERATE GAUSS						
SS411A	NS	NS	NS	NS	NS	NS
SS413A	NS	NS	NS	NS	NS	NS
SS441A	50	53	55	45	40	35
SS443A	110	110	110	90	80	65
SS449A	285	305	310	290	270	260
SS461A	5	5	10	10	5	5
SS466A	100	100	100	95	80	70
MAX OPERATE GAUSS						
SS411A	70	65	60	60	65	70
SS413A	140	140	140	140	140	140
SS441A	135	117	115	120	123	125
SS443A	215	190	180	180	190	200
SS449A	435	400	390	400	410	420
SS461A	110	90	85	85	100	110
SS466A	200	185	180	180	180	185
MIN RELEASE GAUSS						
SS411A	-70	-65	-60	-60	-65	-70
SS413A	-140	-140	-140	-140	-140	-140
SS441A	20	20	20	15	15	10
SS443A	80	80	75	70	60	55
SS449A	210	230	235	215	200	185
SS461A	-110	-90	-85	-85	-100	-110
SS466A	-200	-185	-180	-180	-100	-185
MAX RELEASE GAUSS						
SS411A	NS	NS	NS	NS	NS	NS
SS413A	NS	NS	NS	NS	NS	NS
SS441A	120	99	95	105	115	120
SS443A	190	165	155	165	180	195
SS449A	360	325	315	325	340	345
SS461A	-5	-5	-10	-10	-5	-5
SS466A	-100	-100	-100	-95	-80	-70
MIN DIFF GAUSS						
SS411A	15	15	15	12	12	10
SS413A	20	20	20	20	20	20
SS441A	15	15	20	15	8	5
SS443A	25	25	25	15	10	5
SS449A	30	30	30	30	30	30
SS461A	50	50	50	50	50	50
SS466A	200	200	200	190	160	140

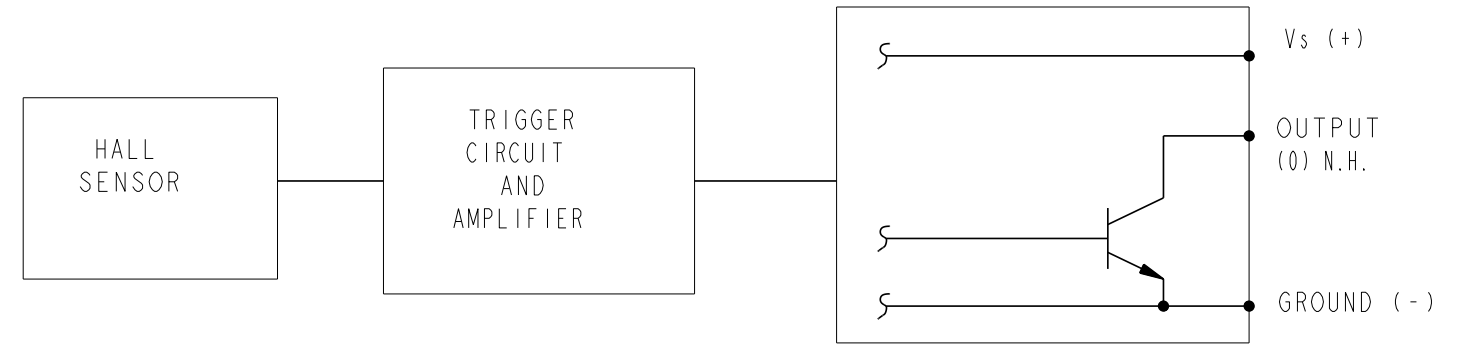

TABLE 2

PACKING	BAG
SPECIFIED VOLTAGE RANGE	3.8 - 30
MAX Ioff milliamp	15
MAX Ion milliamp	15
RATED SINK CURRENT Ma	20
MAX Vsat VOLTS	16
MAX LEAKAGE AT 24V, UA	17
RISE TIME AT 25°C 10% TO 90% μ S	4
FALL TIME AT 25°C 90% TO 10% μ S	4
STORAGE TEMP °C	-65 TO +160
OPERATING TEMP °C	-55 TO +160

TABLE 4

CATALOG LISTING	MAGNETIC TYPE	BRAND SYMBOL
SS411A	BIPOLAR	11A
SS413A	BIPOLAR	13A
SS441A	UNIPOLAR	41A
SS443A	UNIPOLAR	43A
SS449A	UNIPOLAR	49A
SS461A	LATCH	61A
SS466A	LATCH	66A

ABSOLUTE LIMITS $\triangle 3$ TABLE 3

SUPPLY VOLTAGE	-1 TO +30
APPLIED OUTPUT VOLTAGE	-0.5 TO +30
OUTPUT CURRENT mA	SEE TABLE 5
MAGNETIC FLUX GAUSS	NO LIMIT

TABLE 5

OUTPUT CURRENT ABSOLUTE LIMITS	
SUPPLY VOLTAGE	OUTPUT CURRENT MAX, MA
-1 TO 24	50
24 TO 25	37
25 TO 26	33
26 TO 27	28
27 TO 28	24
28 TO 29	19
29 TO 30	15



THIRD ANGLE PROJECTION

SCALE NONE

DO NOT SCALE PRINT

UNLESS OTHERWISE SPECIFIED TOLERANCES ARE

ONE PLACE (.0)	±.030
TWO PLACE (.00)	±.015
THREE PLACE (.000)	±.005
ANGLES	±
WEIGHT	

CATALOG LISTING
SS400 SERIES CHART 1

PAGE 4 OF 4

ISSUE
16

REVISIONS

E 0034535
PRS
26 OCT 07

REPLACES -

CHECK

CHECK

CHECK

CHECK

14 JAN 99

JAF

CHECK

14 JAN 99

3D

DRAWN

KED

ANSI Y14.5M-1982 APPLIES

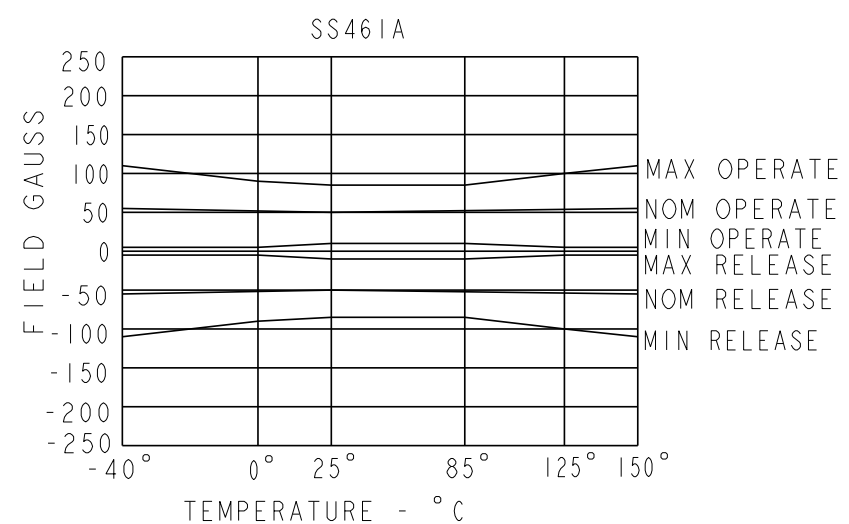
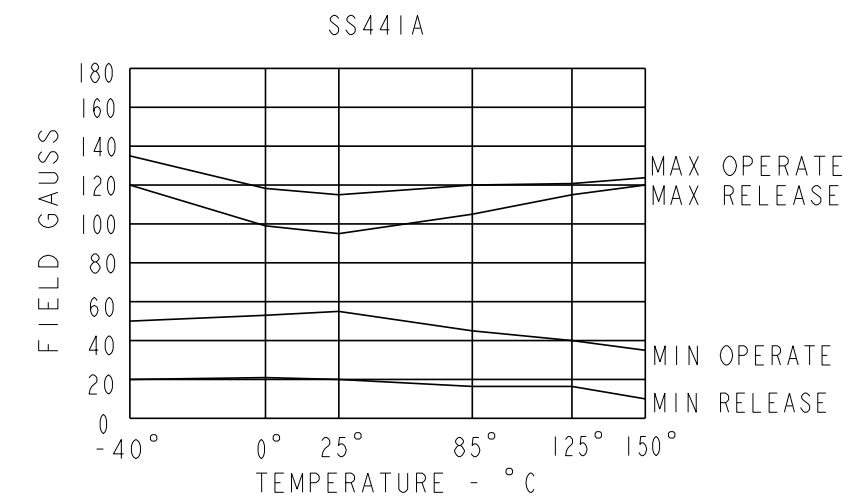
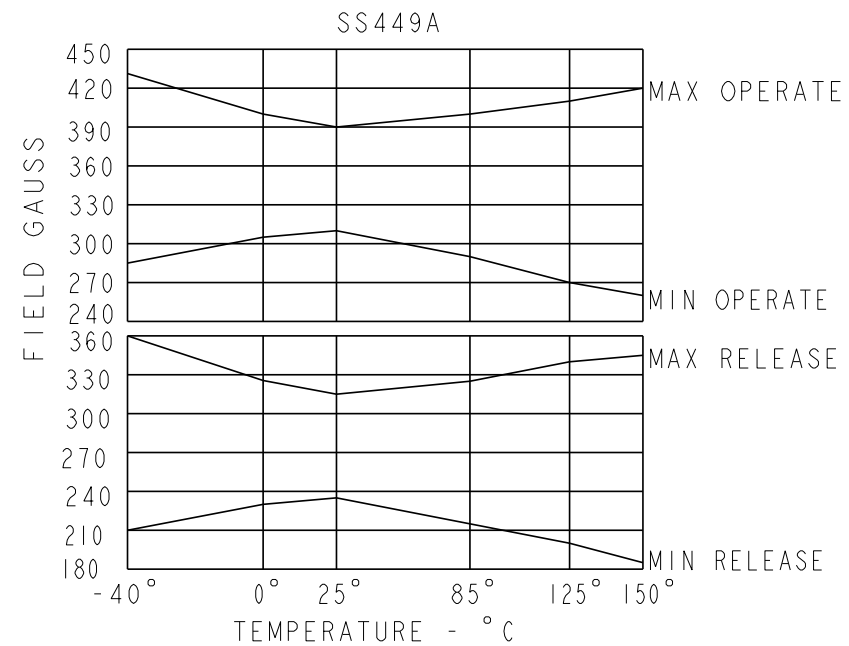
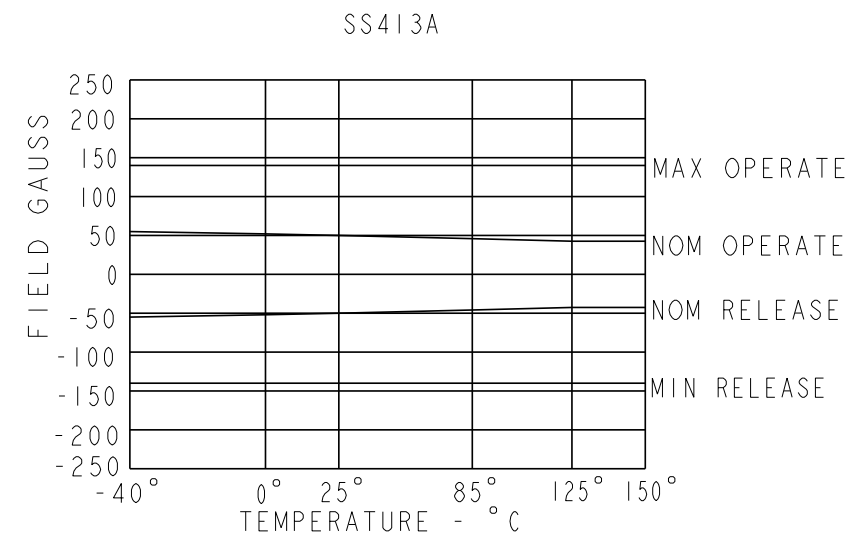
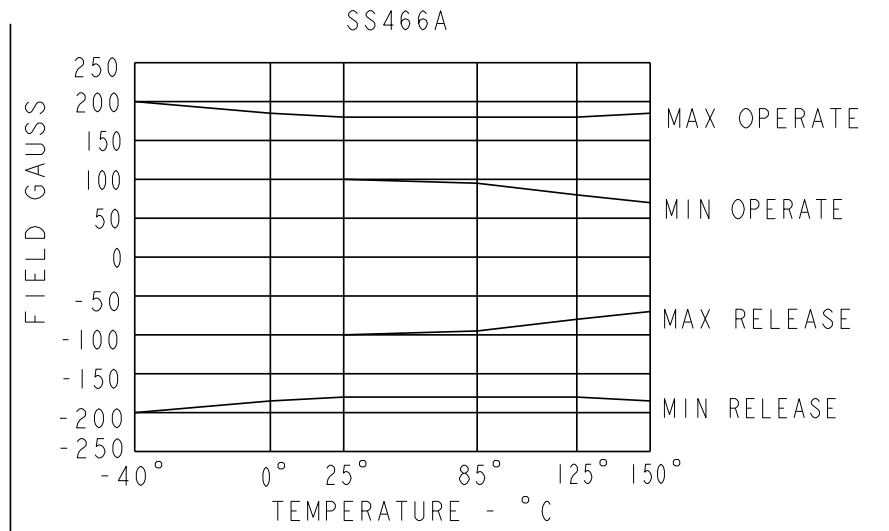
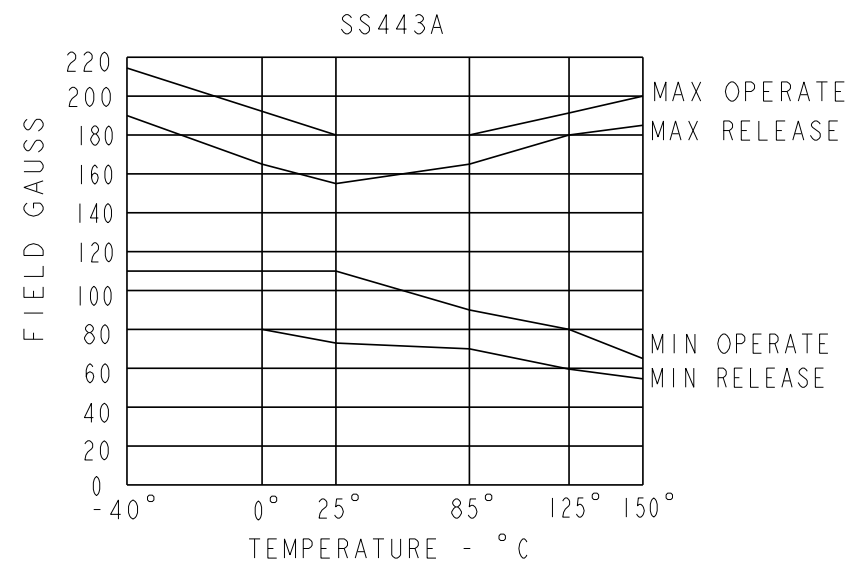
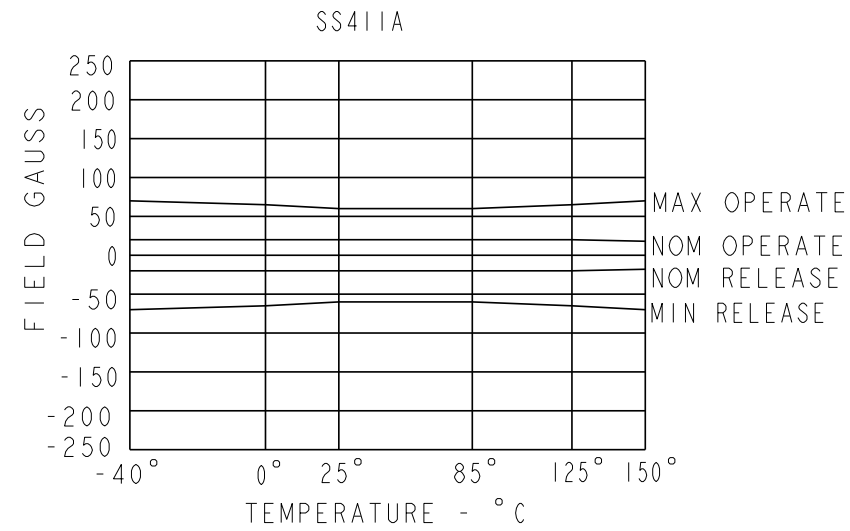

CAUTION
ELECTROSTATIC SENSITIVE DEVICES
DO NOT OPEN OR HANDLE EXCEPT AT A STATIC FREE WORKSTATION

ESD SENSITIVITY:
CLASS 3

THIRD ANGLE PROJECTION	
SCALE	NONE
DO NOT SCALE PRINT	
UNLESS OTHERWISE SPECIFIED TOLERANCES ARE	
ONE PLACE	(.0) ±.030
TWO PLACE	(.00) ±.015
THREE PLACE	(.000) ±.005
ANGLES	±
WEIGHT	



Компания «ЭлектроПласт» предлагает заключение долгосрочных отношений при поставках импортных электронных компонентов на взаимовыгодных условиях!

Наши преимущества:

- Оперативные поставки широкого спектра электронных компонентов отечественного и импортного производства напрямую от производителей и с крупнейших мировых складов;
- Поставка более 17-ти миллионов наименований электронных компонентов;
- Поставка сложных, дефицитных, либо снятых с производства позиций;
- Оперативные сроки поставки под заказ (от 5 рабочих дней);
- Экспресс доставка в любую точку России;
- Техническая поддержка проекта, помощь в подборе аналогов, поставка прототипов;
- Система менеджмента качества сертифицирована по Международному стандарту ISO 9001;
- Лицензия ФСБ на осуществление работ с использованием сведений, составляющих государственную тайну;
- Поставка специализированных компонентов (Xilinx, Altera, Analog Devices, Intersil, Interpoint, Microsemi, Aeroflex, Peregrine, Syfer, Eurofarad, Texas Instrument, Miteq, Cobham, E2V, MA-COM, Hittite, Mini-Circuits, General Dynamics и др.);

Помимо этого, одним из направлений компании «ЭлектроПласт» является направление «Источники питания». Мы предлагаем Вам помощь Конструкторского отдела:

- Подбор оптимального решения, техническое обоснование при выборе компонента;
- Подбор аналогов;
- Консультации по применению компонента;
- Поставка образцов и прототипов;
- Техническая поддержка проекта;
- Защита от снятия компонента с производства.



Как с нами связаться

Телефон: 8 (812) 309 58 32 (многоканальный)

Факс: 8 (812) 320-02-42

Электронная почта: org@eplast1.ru

Адрес: 198099, г. Санкт-Петербург, ул. Калинина, дом 2, корпус 4, литера А.