

Features

- UNII, Hiperlan, and 802.11a+b/g Applications
- Broadband Performance: DC-6 GHz
- Low Insertion Loss: 0.9 dB at 6 GHz
- High Isolation: 28 dB Typical
- Fast Switching Speed: 0.5 μ m GaAs PHEMT
- High Power: 36 dBm P1dB
- Fast Settling for Low Gate Lag Requirements
- Lead-Free 3 mm 12-lead PQFN Package
- 100% Matte Tin Plating over Copper
- Halogen-Free "Green" Mold Compound
- RoHS* Compliant and 260°C Reflow Compatible

Description

M/A-COM's MASW-007588 is a broadband GaAs PHEMT MMIC SPDT switch in a low cost, lead-free 3 mm 12-lead PQFN package. The MASW-007588 is ideally suited for applications where very small size and low cost are required.

The MASW-007588, with its small size and low height, is ideal for 802.11a and 802.11b/g PC card and access point applications.

The MASW-007588 delivers high isolation, low insertion loss and high linearity up to 6 GHz.

The MASW-007588 is fabricated using a 0.5 micron gate length GaAs PHEMT process. The process features full passivation for performance and reliability.

Functional Schematic

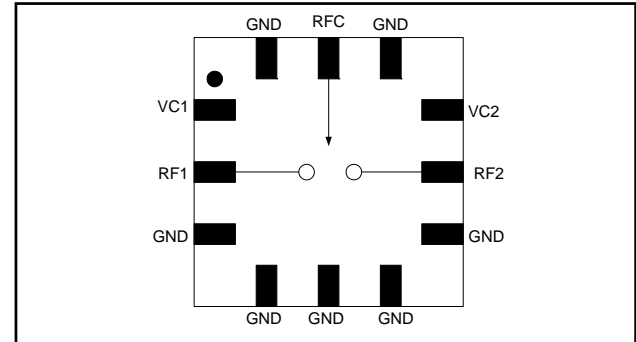

Pin Configuration

PIN No.	PIN Name	Description
1	VC1	Control 1
2	RF1	RF Port 1
3	GND	Ground
4	GND	Ground
5	GND	Ground
6	GND	Ground
7	GND	Ground
8	RF2	RF Port 2
9	VC2	Control 2
10	GND	Ground
11	RFC	RF Input
12	GND	Ground
13	Paddle ²	RF and DC Ground

2. The exposed pad centered on the package bottom must be connected to RF and DC ground.

Absolute Maximum Ratings^{3,4}

Parameter	Absolute Maximum
Input Power @ 3 V Control	+37 dBm
Input Power @ 5 V Control	+39 dBm
Operating Voltage	+8.5 volts
Operating Temperature	-40°C to +85°C
Storage Temperature	-65°C to +150°C

3. Exceeding any one or combination of these limits may cause permanent damage to this device.
4. M/A-COM does not recommend sustained operation near these survivability limits.

Ordering Information¹

Part Number	Package
MASW-007588-TR3000	3000 piece reel
MASW-007588-000SMB	Sample Test Board (Includes 5 Samples)

1. Reference Application Note M513 for reel size information.

* Restrictions on Hazardous Substances, European Union Directive 002/95/EC.

ADVANCED: Data Sheets contain information regarding a product M/A-COM Technology Solutions is considering for development. Performance is based on target specifications, simulated results, and/or prototype measurements. Commitment to develop is not guaranteed.

PRELIMINARY: Data Sheets contain information regarding a product M/A-COM Technology Solutions has under development. Performance is based on engineering tests. Specifications are typical. Mechanical outline has been fixed. Engineering samples and/or test data may be available. Commitment to produce in volume is not guaranteed.

• **North America** Tel: 800.366.2266 / Fax: 978.366.2266
 • **Europe** Tel: 44.1908.574.200 / Fax: 44.1908.574.300
 • **Asia/Pacific** Tel: 81.44.844.8296 / Fax: 81.44.844.8298
 Visit www.macomtech.com for additional data sheets and product information.

M/A-COM Technology Solutions Inc. and its affiliates reserve the right to make changes to the product(s) or information contained herein without notice.

Electrical Specifications⁵: $T_A = 25^\circ\text{C}$, $Z_0 = 50\Omega$, $V_c = 0\text{ V}/3\text{ V}$, $\text{Pin} = 0\text{ dBm}$

Parameter	Test Conditions	Units	Min.	Typ.	Max.
Insertion Loss	2.4 GHz	dB	—	0.70	1.05
	5.3 GHz	dB	—	0.85	1.2
	5.8 GHz	dB	—	0.85	1.2
Isolation	2.4 GHz	dB	24	29	—
	5.3 GHz	dB	23	28	—
	5.8 GHz	dB	21	26	—
Return Loss	DC - 6 GHz	dB	—	20	—
IP2	Two Tone, +15 dBm/Tone, 5 MHz Spacing, >50 MHz				
	2.4 GHz, $V_c = 3.0\text{ V}$	dBm	—	98	—
	5.8 GHz, $V_c = 3.0\text{ V}$	dBm	—	81	—
	2.4 GHz, $V_c = 5.0\text{ V}$	dBm	—	107	—
IIP3	Two Tone, +15 dBm/Tone, 5 MHz Spacing, >50 MHz				
	2.4 GHz, $V_c = 3.0\text{ V}$	dBm	—	57	—
	5.8 GHz, $V_c = 3.0\text{ V}$	dBm	—	53	—
	2.4 GHz, $V_c = 5.0\text{ V}$	dBm	—	57	—
Input P-1dB	2.4 GHz	dBm	—	40	—
	5.3 GHz	dBm	—	36	—
	5.8 GHz	dBm	—	37	—
2nd Harmonic	2.4 GHz, $\text{Pin} = +20\text{ dBm}$	dBm	—	-72	—
	5.8 GHz, $\text{Pin} = +20\text{ dBm}$	dBm	—	-69	—
3rd Harmonic	2.4 GHz, $\text{Pin} = +20\text{ dBm}$	dBm	—	-85	—
	5.8 GHz, $\text{Pin} = +20\text{ dBm}$	dBm	—	-75	—
T-rise, T-fall	10% to 90% RF and 90% to 10% RF	nS	—	55	—
Ton, Toff	50% control to 90% RF, and 50% control to 10% RF	nS	—	80	—
Transients	—	mV	—	14	—
Control Current	$ V_c = 3\text{ V}$	μA	—	15	25

Truth Table^{5,6,7}

Control V1	Control V2	RFC—RF1	RFC—RF2
1	0	On	Off
0	1	Off	On

- For positive voltage control, external DC blocking capacitors are required on all RF ports.
- Differential voltage, $V(\text{state } 1) - V(\text{state } 0)$, must be +2.7 V minimum and must not exceed +5 V.
- $0 = 0 \pm 0.2\text{ V}$, $1 = +2.9\text{ V}$ to +5 V.

Handling Procedures

Please observe the following precautions to avoid damage:

Static Sensitivity

Gallium Arsenide Integrated Circuits are sensitive to electrostatic discharge (ESD) and can be damaged by static electricity. Proper ESD control techniques should be used when handling these devices.

Typical Performance Curves

Insertion Loss

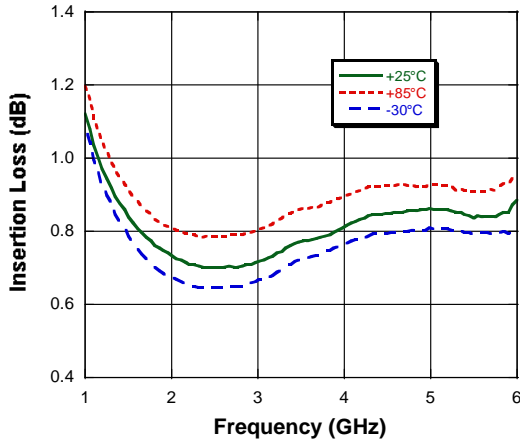

Isolation

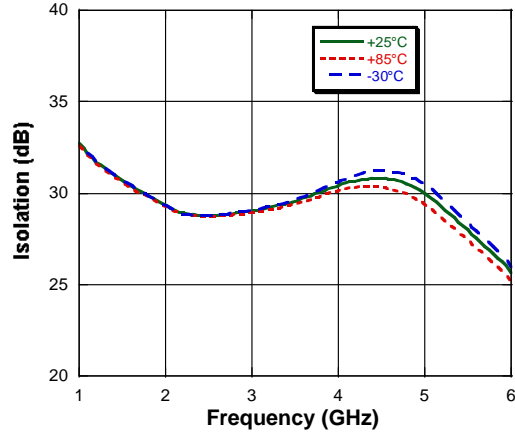

Return Loss

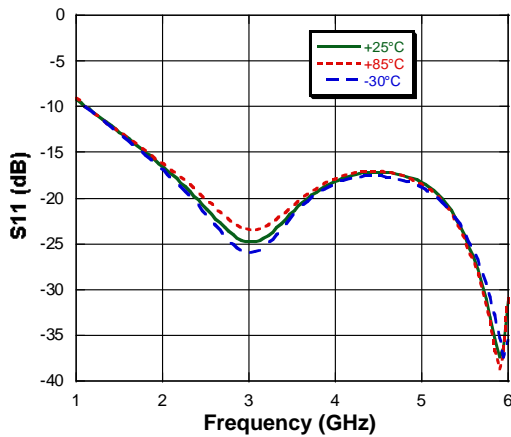

Application Schematic

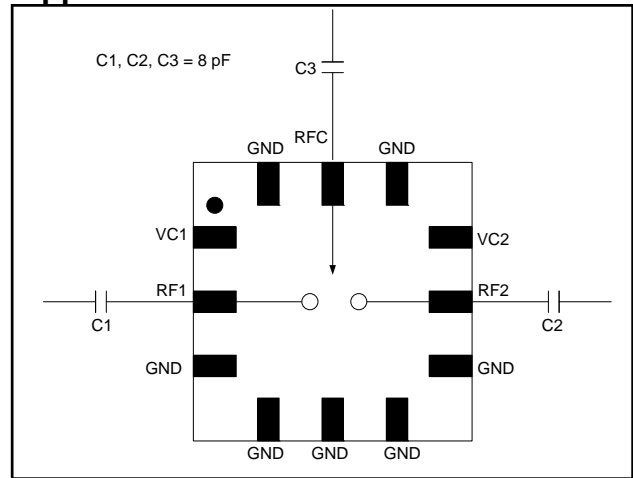

Lead-Free 3 mm 12-lead PQFN[†]

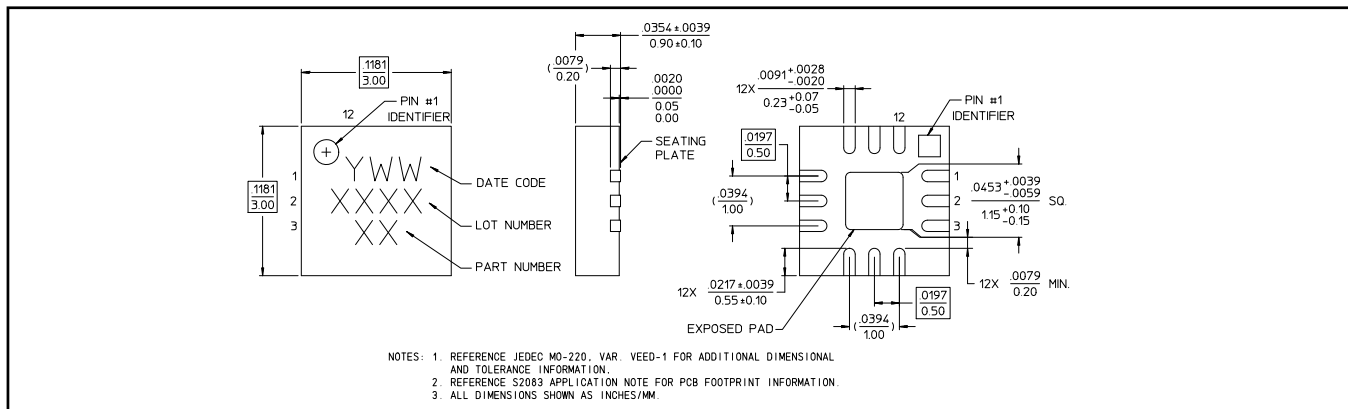

[†] Reference Application Note M538 for lead-free solder reflow recommendations.

ADVANCED: Data Sheets contain information regarding a product M/A-COM Technology Solutions is considering for development. Performance is based on target specifications, simulated results, and/or prototype measurements. Commitment to develop is not guaranteed.
PRELIMINARY: Data Sheets contain information regarding a product M/A-COM Technology Solutions has under development. Performance is based on engineering tests. Specifications are typical. Mechanical outline has been fixed. Engineering samples and/or test data may be available. Commitment to produce in volume is not guaranteed.

• **North America** Tel: 800.366.2266 / Fax: 978.366.2266
• **Europe** Tel: 44.1908.574.200 / Fax: 44.1908.574.300
• **Asia/Pacific** Tel: 81.44.844.8296 / Fax: 81.44.844.8298
Visit www.macomtech.com for additional data sheets and product information.

M/A-COM Technology Solutions Inc. and its affiliates reserve the right to make changes to the product(s) or information contained herein without notice.



Компания «ЭлектроПласт» предлагает заключение долгосрочных отношений при поставках импортных электронных компонентов на взаимовыгодных условиях!

Наши преимущества:

- Оперативные поставки широкого спектра электронных компонентов отечественного и импортного производства напрямую от производителей и с крупнейших мировых складов;
- Поставка более 17-ти миллионов наименований электронных компонентов;
- Поставка сложных, дефицитных, либо снятых с производства позиций;
- Оперативные сроки поставки под заказ (от 5 рабочих дней);
- Экспресс доставка в любую точку России;
- Техническая поддержка проекта, помощь в подборе аналогов, поставка прототипов;
- Система менеджмента качества сертифицирована по Международному стандарту ISO 9001;
- Лицензия ФСБ на осуществление работ с использованием сведений, составляющих государственную тайну;
- Поставка специализированных компонентов (Xilinx, Altera, Analog Devices, Intersil, Interpoint, Microsemi, Aeroflex, Peregrine, Syfer, Eurofarad, Texas Instrument, Miteq, Cobham, E2V, MA-COM, Hittite, Mini-Circuits, General Dynamics и др.);

Помимо этого, одним из направлений компании «ЭлектроПласт» является направление «Источники питания». Мы предлагаем Вам помощь Конструкторского отдела:

- Подбор оптимального решения, техническое обоснование при выборе компонента;
- Подбор аналогов;
- Консультации по применению компонента;
- Поставка образцов и прототипов;
- Техническая поддержка проекта;
- Защита от снятия компонента с производства.



Как с нами связаться

Телефон: 8 (812) 309 58 32 (многоканальный)

Факс: 8 (812) 320-02-42

Электронная почта: org@eplast1.ru

Адрес: 198099, г. Санкт-Петербург, ул. Калинина, дом 2, корпус 4, литера А.