

2 W High Gain Power Amplifier for Cellular Infrastructure

InGaP GaAs HBT

The MMZ27333B is a versatile 3-stage power amplifier targeted at driver and pre-driver applications for macro and micro base stations and final-stage applications for small cells. Its versatile design allows operation in any frequency band from 1500 to 2700 MHz providing gain of more than 35 dB. The device operates off a 5 V supply, and its bias currents and portions of the matching networks are adjustable for optimum performance in any specific application. It is housed in a QFN 4 × 4 surface mount package.

- Typical PA Driver Performance: $V_{CC1} = V_{CC2} = V_{CC3} = V_{BIAS} = 5$ Vdc, $I_{CQ} = 430$ mA.

Frequency	P _{out} (dBm)	G _{ps} (dB)	ACPR (dBc)	I _{cc} Total	Test Signal
2140 MHz	22.3	35.8	-48.0	499	W-CDMA
2600 MHz	21.3	36.1	-48.0	498	LTE 20 MHz

Features

- P1dB: up to 33 dBm
- Gain: More than 35 dB
- 5 V Supply
- Excellent Linearity
- High Efficiency
- Single-ended Power Detector
- Band Tunable
- Cost-effective 24-pin, 4 mm QFN surface mount plastic package

MMZ27333BT1

**1500–2700 MHz, 35 dB, 33 dBm
 InGaP HBT LINEAR AMPLIFIER**

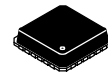

QFN 4 × 4

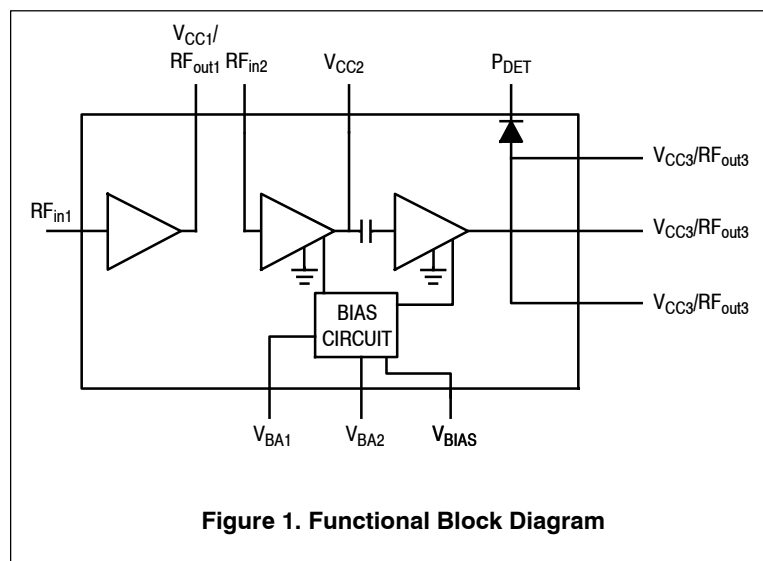

Figure 1. Functional Block Diagram

Table 1. Maximum Ratings

Rating	Symbol	Value	Unit
Supply Voltage	V_{CC}	6	V
Supply Current	I_{CC1} I_{CC2} I_{CC3}	68 240 960	mA
RF Input Power	P_{in}	10	dBm
Storage Temperature Range	T_{stg}	-65 to +150	°C
Junction Temperature	T_J	175	°C

Table 2. Thermal Characteristics

Characteristic	Symbol	Value (1)	Unit
Thermal Resistance, Junction to Case Case Temperature 95°C, $V_{CC1} = V_{CC2} = V_{CC3} = V_{BIAS} = 5$ Vdc	$R_{\theta JC}$	75 79 21	°C/W
	Stage 1		
	Stage 2		
	Stage 3		

Table 3. Electrical Characteristics ($V_{CC1} = V_{CC2} = V_{CC3} = V_{BIAS} = 5$ Vdc, 2600 MHz, $T_A = 25^\circ\text{C}$, 50 ohm system, in NXP PA Driver Application Circuit tuned for LTE application)

Characteristic	Symbol	Min	Typ	Max	Unit
Small-Signal Gain (S21)	G_p	34.8	35.8	—	dB
Input Return Loss (S11)	IRL	—	17	—	dB
Output Return Loss (S22)	ORL	—	13.3	—	dB
Power Output @ 1dB Compression	P1dB	—	32.2	—	dBm
Total Supply Current ($I_{CC1} + I_{CC2} + I_{CC3} + I_{BIAS}$)	I_{CQ}	420	430	445	mA
Supply Voltage	V_{CC}	—	5	—	V

Table 4. ESD Protection Characteristics

Test Methodology	Class
Human Body Model (per JESD22-A114)	1C
Machine Model (per EIA/JESD22-A115)	A
Charge Device Model (per JESD22-C101)	IV

Table 5. Moisture Sensitivity Level

Test Methodology	Rating	Package Peak Temperature	Unit
Per JESD22-A113, IPC/JEDEC J-STD-020	1	260	°C

Table 6. Ordering Information

Device	Tape and Reel Information	Package
MMZ27333BT1	T1 Suffix = 1,000 Units, 12 mm Tape Width, 7-inch Reel	QFN 4 × 4

1. Refer to AN1955, *Thermal Measurement Methodology of RF Power Amplifiers*. Go to <http://www.nxp.com/RF> and search for AN1955.

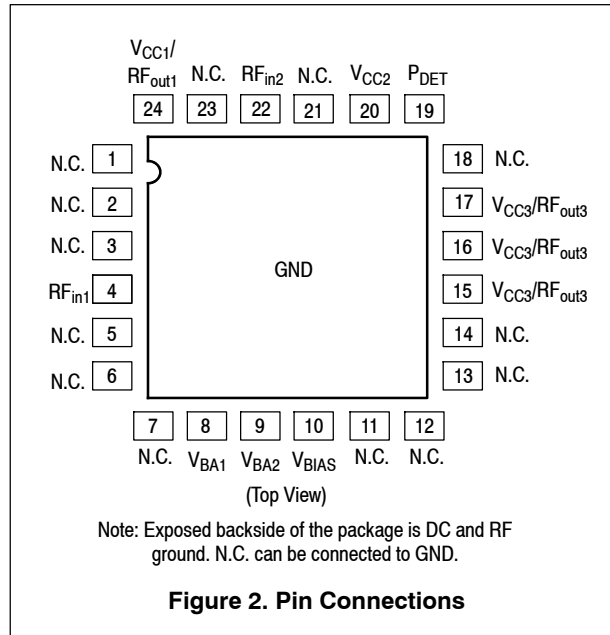

50 OHM APPLICATION CIRCUIT: 2500–2700 MHz, 5 VOLT OPERATION

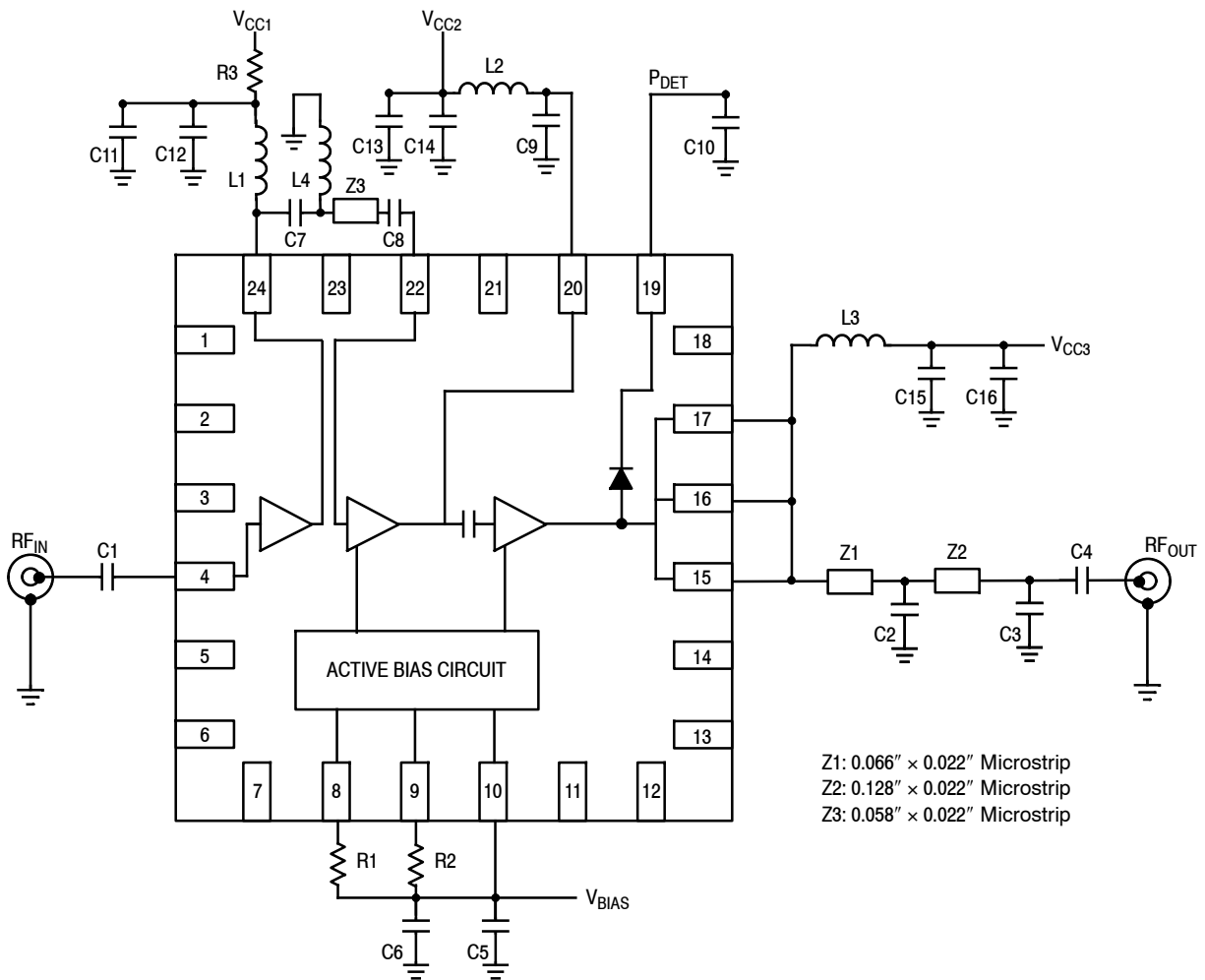

Figure 3. MMZ27333BT1 Test Circuit Schematic

Table 7. MMZ27333BT1 Test Circuit Component Designations and Values

Part	Description	Part Number	Manufacturer
C1, C4	22 pF Chip Capacitors	04023K220BBS	AVX
C2	2.0 pF Chip Capacitor	04023J2R0BBS	AVX
C3	1.8 pF Chip Capacitor	04023J1R8BBS	AVX
C5, C11, C13, C15	1000 pF Chip Capacitors	GCM155R71E103KA37D	Murata
C6, C14	1 μF Chip Capacitors	GRM188R61A105KA61D	Murata
C7	1.5 pF Chip Capacitor	GRM1555C1H1R5BA91D	Murata
C8	0.8 pF Chip Capacitor	GRM1555C1HR80BA01D	Murata
C9	7.5 pF Chip Capacitor	04023J7R5BBS	AVX
C10	470 pF Chip Capacitor	GRM1555C1H471JA01D	Murata
C12	0.01 μF Chip Capacitor	C0603C103J5RACTU	Kemet
C16	4.7 μF Chip Capacitor	GRM188R60J475KE19D	Murata
L1	56 nH Chip Inductor	0603CS-56NXJL	Coilcraft
L2	10 nH Chip Inductor	0603HC-10NXLLW	Coilcraft
L3	6.8 nH Chip Inductor	0603HC-6N8XJLW	Coilcraft
L4	1.8 nH Chip Inductor	LL1005-FHL1N85	TOKO
R1	1.2 kΩ Chip Resistor	RC0402FR-071K20L	Yageo
R2	330 Ω, 1/16 W Chip Resistor	CRCW0402330RFKED	Vishay
R3	0 Ω, 1 A Chip Resistor	ERJ2GEY0R00V	Panasonic
PCB	Rogers RO4350B, 0.010", ε _r = 3.66	M70506	MTL

MMZ27333BT1

50 OHM APPLICATION CIRCUIT: 2500–2700 MHz, 5 VOLT OPERATION

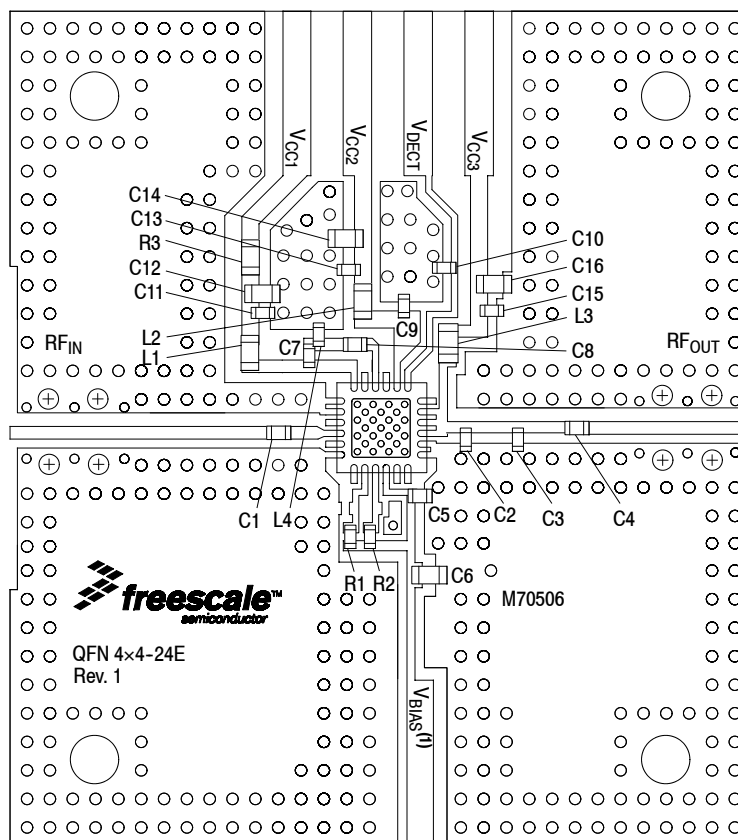

PCB actual size: 1.30" × 1.46".

(1) V_{BIAS} [Board] supplies V_{BA1}, V_{BA2} and V_{BIAS} [Device].

Figure 4. MMZ27333BT1 Test Circuit Component Layout

Table 6. MMZ27333BT1 Test Circuit Component Designations and Values

Part	Description	Part Number	Manufacturer
C1, C4	22 pF Chip Capacitors	04023K220BBS	AVX
C2	2.0 pF Chip Capacitor	04023J2R0BBS	AVX
C3	1.8 pF Chip Capacitor	04023J1R8BBS	AVX
C5, C11, C13, C15	1000 pF Chip Capacitors	GCM155R71E103KA37D	Murata
C6, C14	1 μF Chip Capacitors	GRM188R61A105KA61D	Murata
C7	1.5 pF Chip Capacitor	GRM1555C1H1R5BA91D	Murata
C8	0.8 pF Chip Capacitor	GRM1555C1HR80BA01D	Murata
C9	7.5 pF Chip Capacitor	04023J7R5BBS	AVX
C10	470 pF Chip Capacitor	GRM1555C1H471JA01D	Murata
C12	0.01 μF Chip Capacitor	C0603C103J5RACTU	Kemet
C16	4.7 μF Chip Capacitor	GRM188R60J475KE19D	Murata
L1	56 nH Chip Inductor	0603CS-56NXJL	Coilcraft
L2	10 nH Chip Inductor	0603HC-10NXLLW	Coilcraft
L3	6.8 nH Chip Inductor	0603HC-6N8XJLW	Coilcraft
L4	1.8 nH Chip Inductor	LL1005-FHL1N85	TOKO
R1	1.2 kΩ Chip Resistor	RC0402FR-071K20L	Yageo
R2	330 Ω, 1/16 W Chip Resistor	CRCW0402330RFKED	Vishay
R3	0 Ω, 1 A Chip Resistor	ERJ2GEY0R00V	Panasonic
PCB	Rogers RO4350B, 0.010", ε _r = 3.66	M70506	MTL

(Test Circuit Component Designations and Values table repeated for reference.)

50 OHM APPLICATION CIRCUIT: 2500–2700 MHz, 5 VOLT OPERATION

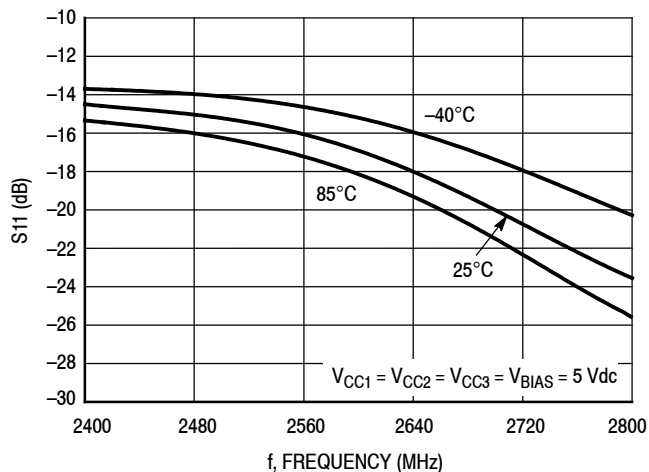

Figure 5. S11 versus Frequency versus Temperature

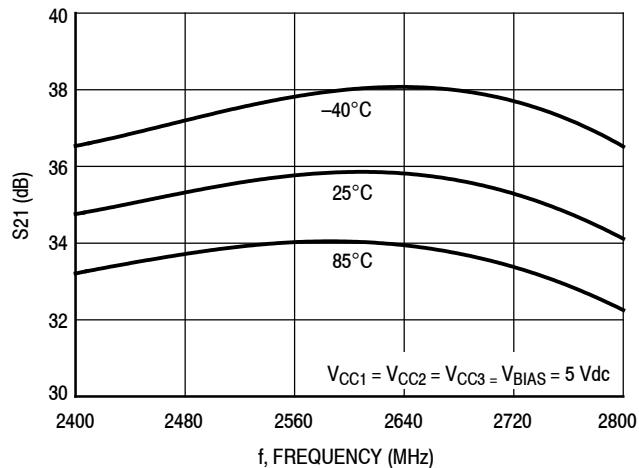

Figure 6. S21 versus Frequency versus Temperature

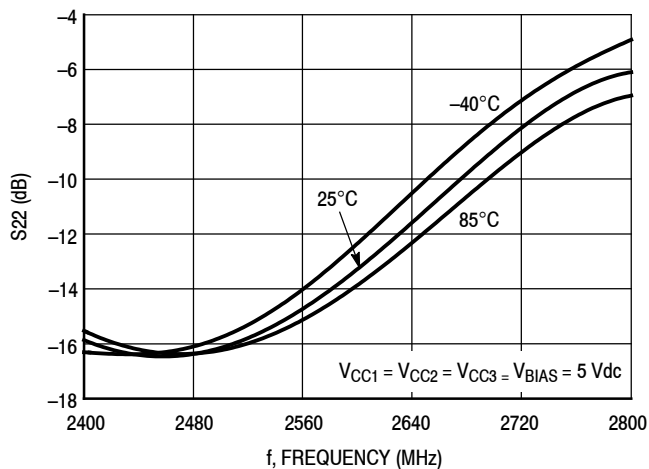

Figure 7. S22 versus Frequency versus Temperature

50 OHM APPLICATION CIRCUIT: 2500–2700 MHz, 5 VOLT OPERATION

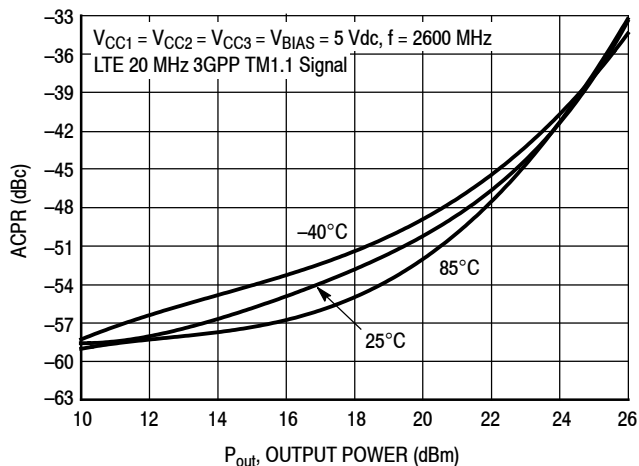

Figure 8. ACPR versus Output Power versus Temperature

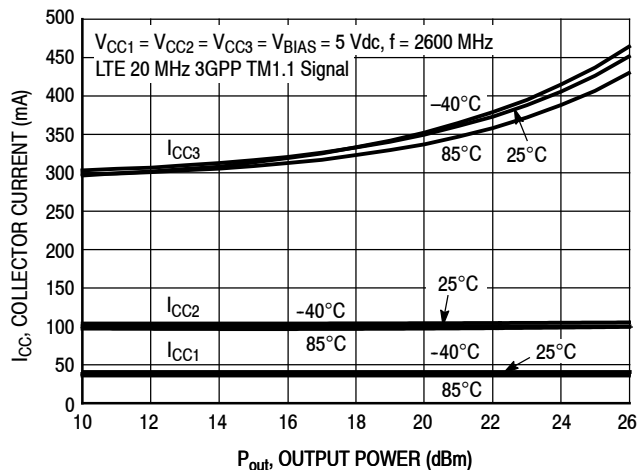

Figure 9. Stage Collector Current versus Output Power versus Temperature

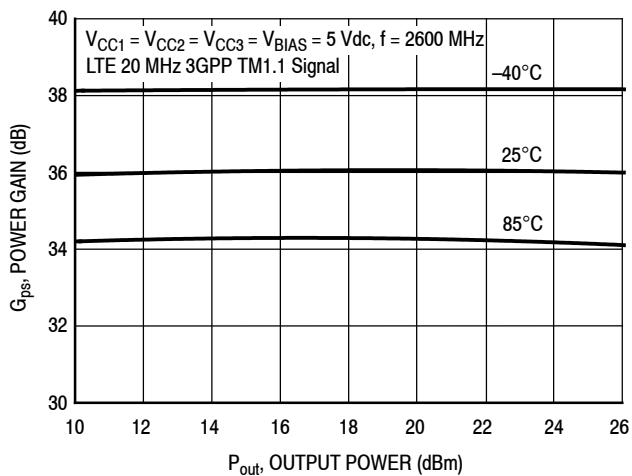

Figure 10. Power Gain versus Output Power versus Temperature

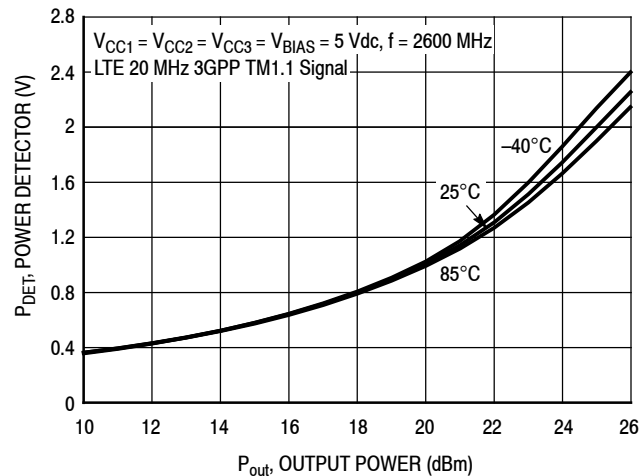

Figure 11. Power Detector versus Output Power versus Temperature

50 OHM APPLICATION CIRCUIT: 2110–2170 MHz, 5 VOLT OPERATION

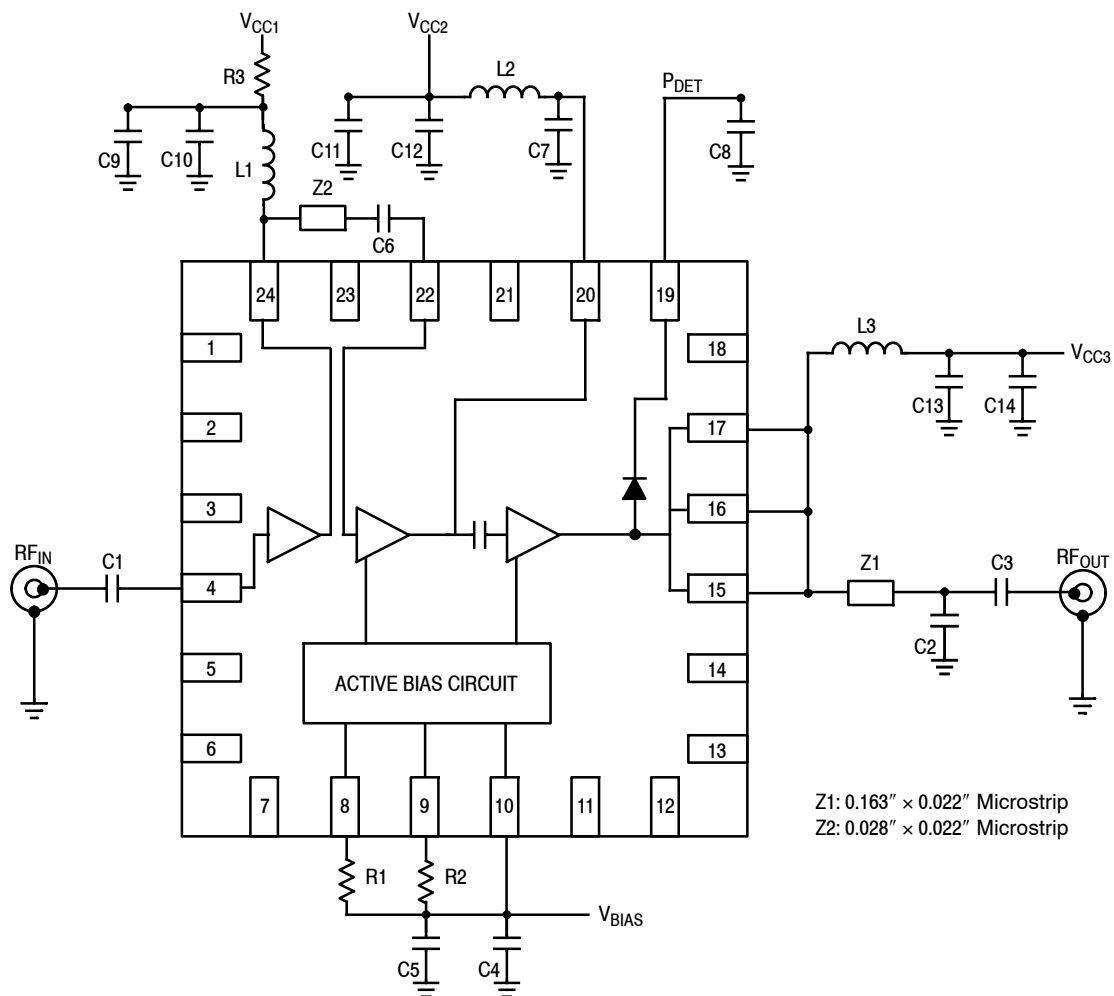
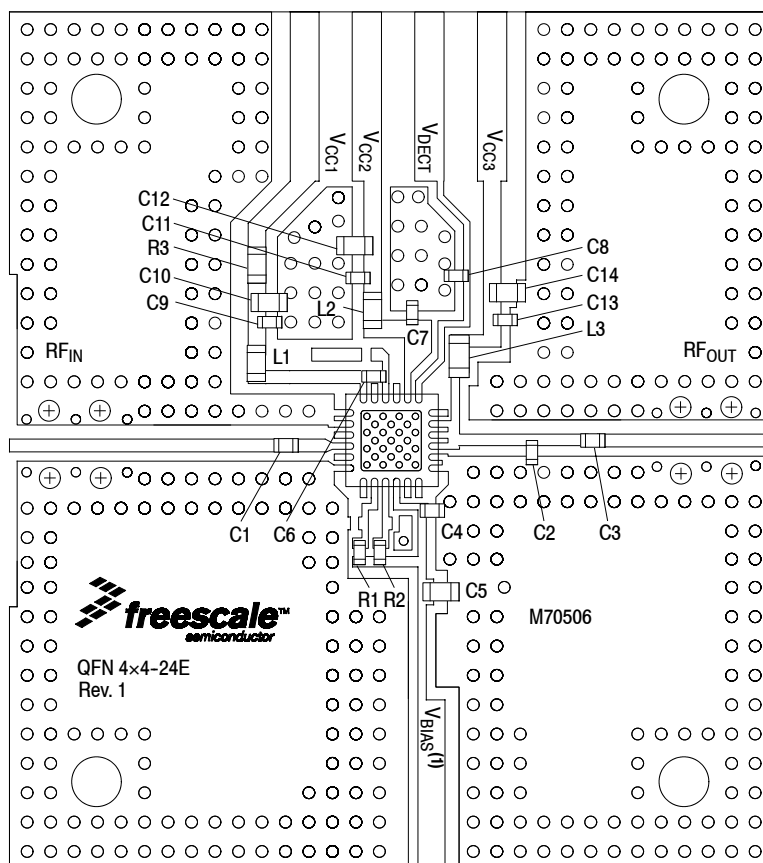

Figure 12. MMZ27333BT1 Test Circuit Schematic

Table 8. MMZ27333BT1 Test Circuit Component Designations and Values

Part	Description	Part Number	Manufacturer
C1, C3	22 pF Chip Capacitors	04023K220BBS	AVX
C2	3.6 pF Chip Capacitor	04023J3R6BBS	AVX
C4, C9, C11, C13	1000 pF Chip Capacitors	GCM155R71E103KA37D	Murata
C5, C12	1 μ F Chip Capacitors	GRM188R61A105KA61D	Murata
C6	22 pF Chip Capacitor	GRM155C1H220GA01D	Murata
C7	8.2 pF Chip Capacitor	04023J8R2BBS	AVX
C8	470 pF Chip Capacitor	GRM1555C1H471JA01D	Murata
C10	0.01 μ F Chip Capacitor	C0603C103J5RACTU	Kemet
C14	4.7 μ F Chip Capacitor	GRM188R60J475KE19D	Murata
L1	56 nH Chip Inductor	0603CS-56NXJL	Coilcraft
L2	12 nH Chip Inductor	0603HC-12NXGLW	Coilcraft
L3	6.8 nH Chip Inductor	0603HC-6N8XJLW	Coilcraft
R1	1.2 k Ω Chip Resistor	RC0402FR-071K20L	Yageo
R2	330 Ω , 1/16 W Chip Resistor	CRCW0402330DFKED	Vishay
R3	0 Ω , 1 A Chip Resistor	ERJ2GEY0R00V	Panasonic
PCB	Rogers RO4350B, 0.010", $\epsilon_r = 3.66$	M70506	MTL

50 OHM APPLICATION CIRCUIT: 2110–2170 MHz, 5 VOLT OPERATION



PCB actual size: 1.30" × 1.46".

(1) V_{BIAS} [Board] supplies V_{BA1} , V_{BA2} and V_{BIAS} [Device].

Figure 13. MMZ27333BT1 Test Circuit Component Layout

Table 7. MMZ27333BT1 Test Circuit Component Designations and Values

Part	Description	Part Number	Manufacturer
C1, C3	22 pF Chip Capacitors	04023K220BBS	AVX
C2	3.6 pF Chip Capacitor	04023J3R6BBS	AVX
C4, C9, C11, C13	1000 pF Chip Capacitors	GCM155R71E103KA37D	Murata
C5, C12	1 μ F Chip Capacitors	GRM188R61A105KA61D	Murata
C6	22 pF Chip Capacitor	GRM155C1H220GA01D	Murata
C7	8.2 pF Chip Capacitor	04023J8R2BBS	AVX
C8	470 pF Chip Capacitor	GRM155C1H471JA01D	Murata
C10	0.01 μ F Chip Capacitor	C0603C103J5RACTU	Kemet
C14	4.7 μ F Chip Capacitor	GRM188R60J475KE19D	Murata
L1	56 nH Chip Inductor	0603CS-56NXJL	Coilcraft
L2	12 nH Chip Inductor	0603HC-12NXGLW	Coilcraft
L3	6.8 nH Chip Inductor	0603HC-6N8XJLW	Coilcraft
R1	1.2 k Ω Chip Resistor	RC0402FR-071K20L	Yageo
R2	330 Ω , 1/16 W Chip Resistor	CRCW0402330DFKED	Vishay
R3	0 Ω , 1 A Chip Resistor	ERJ2GEY0R00V	Panasonic
PCB	Rogers RO4350B, 0.010", $\epsilon_r = 3.66$	M70506	MTL

(Test Circuit Component Designations and Values table repeated for reference.)

50 OHM APPLICATION CIRCUIT: 2110–2170 MHz, 5 VOLT OPERATION

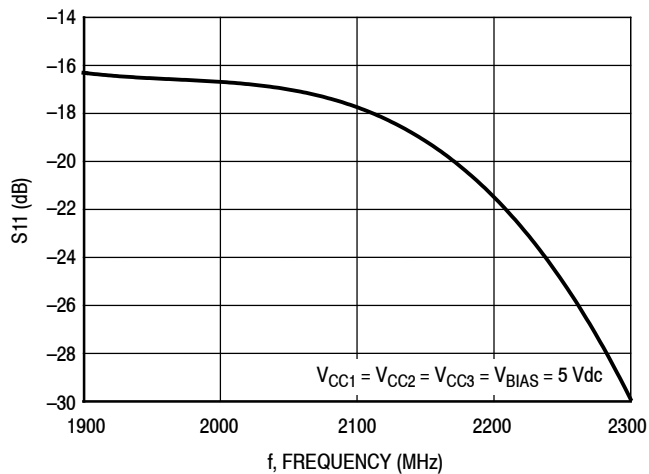

Figure 14. S11 versus Frequency

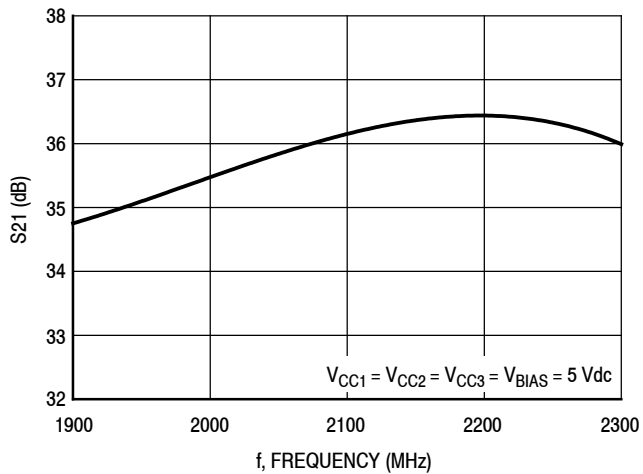

Figure 15. S21 versus Frequency

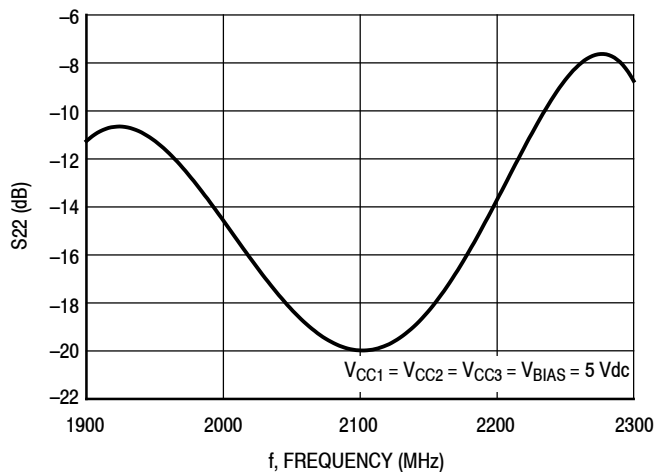

Figure 16. S22 versus Frequency

50 OHM APPLICATION CIRCUIT: 2110–2170 MHz, 5 VOLT OPERATION

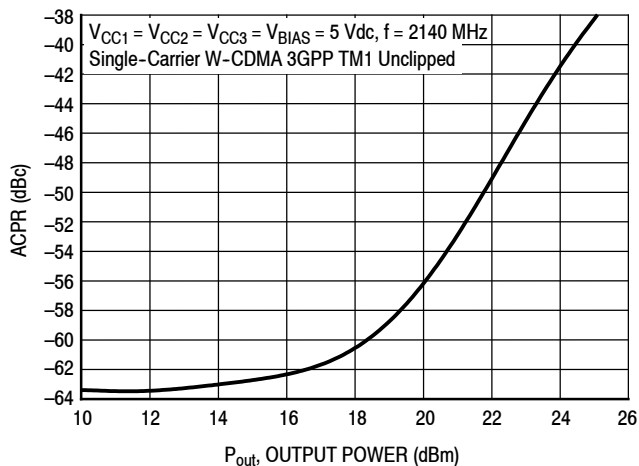

Figure 17. ACPR versus Output Power

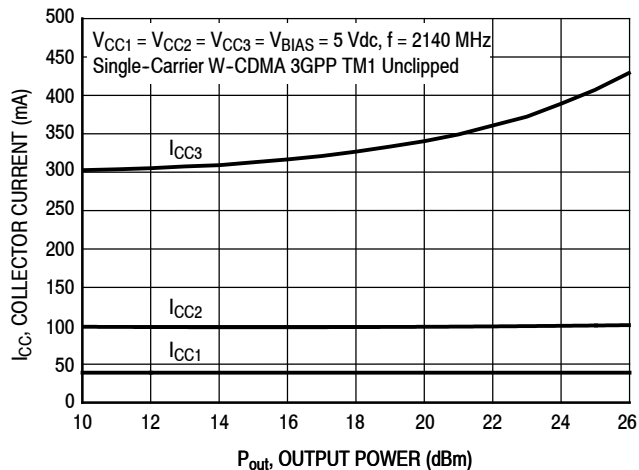

Figure 18. Stage Collector Current versus Output Power

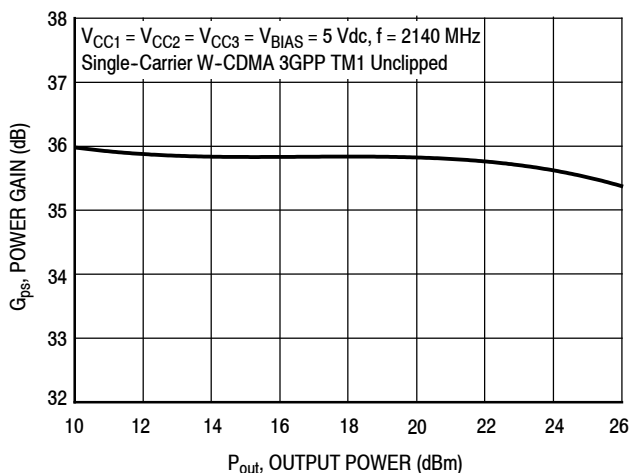

Figure 19. Power Gain versus Output Power

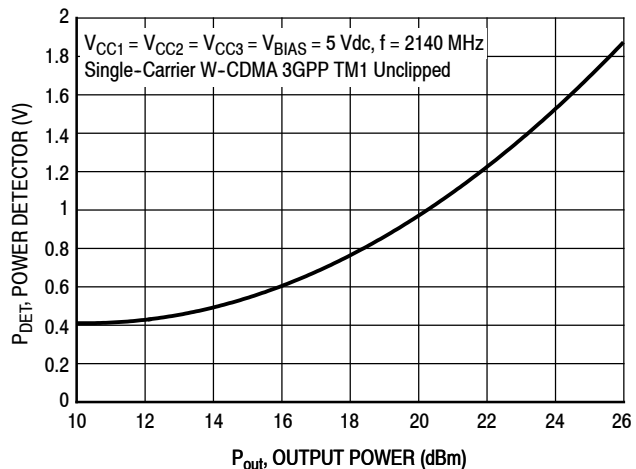

Figure 20. Power Detector versus Output Power

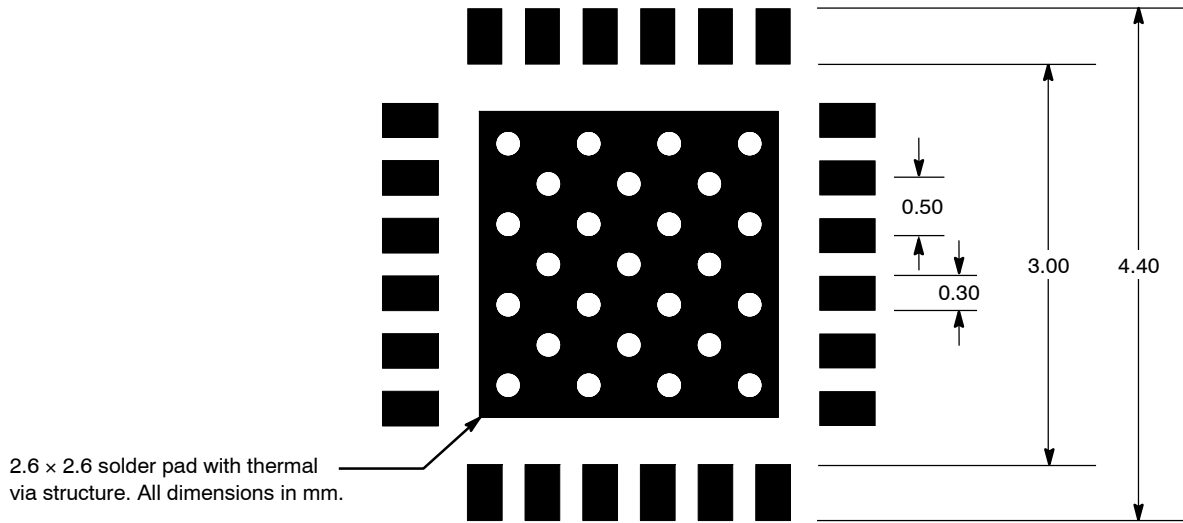

Figure 21. PCB Pad Layout for 24-Lead QFN 4 x 4

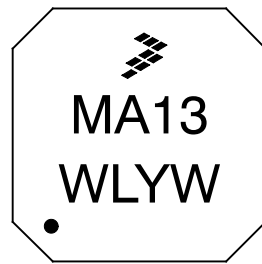
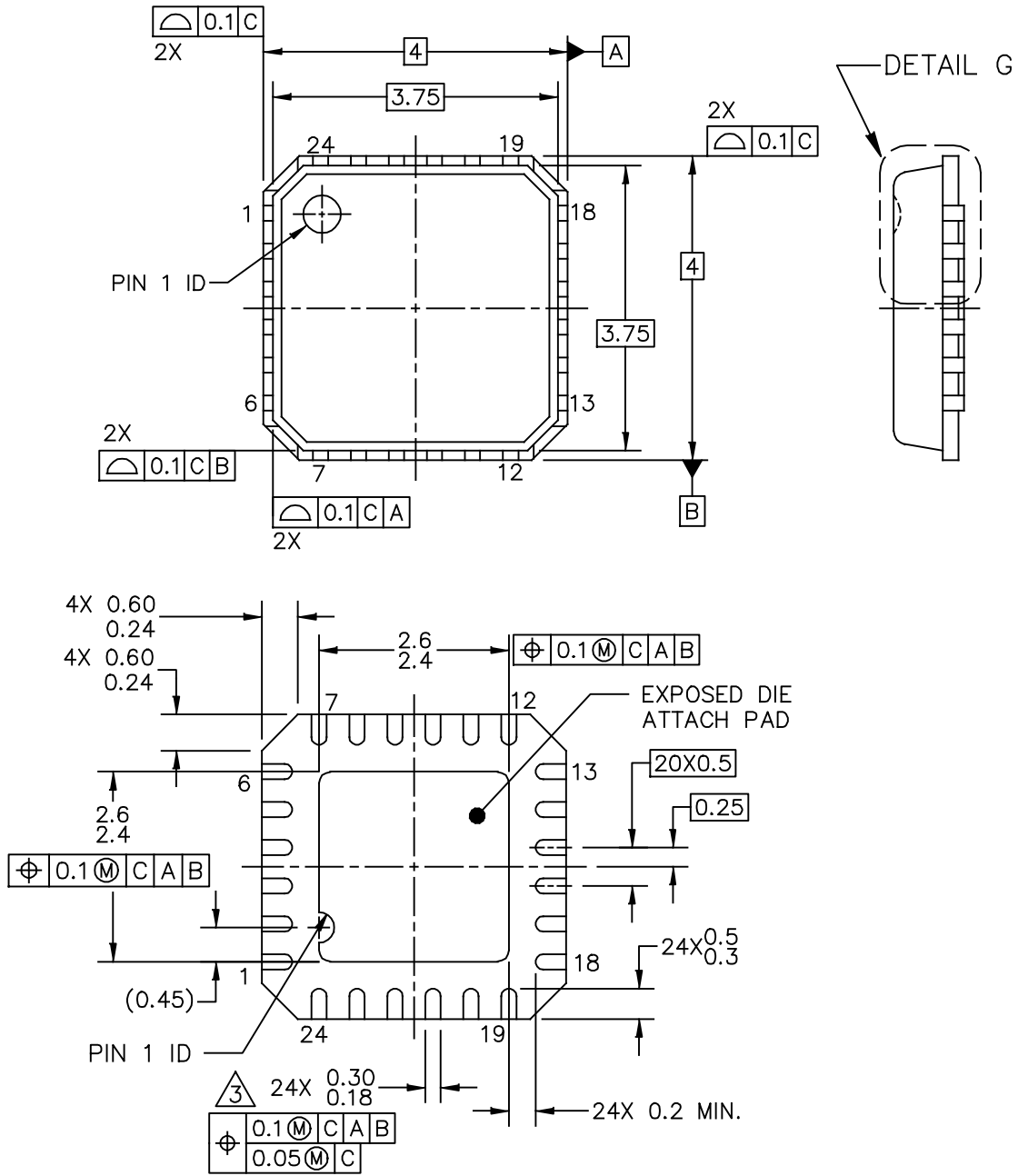
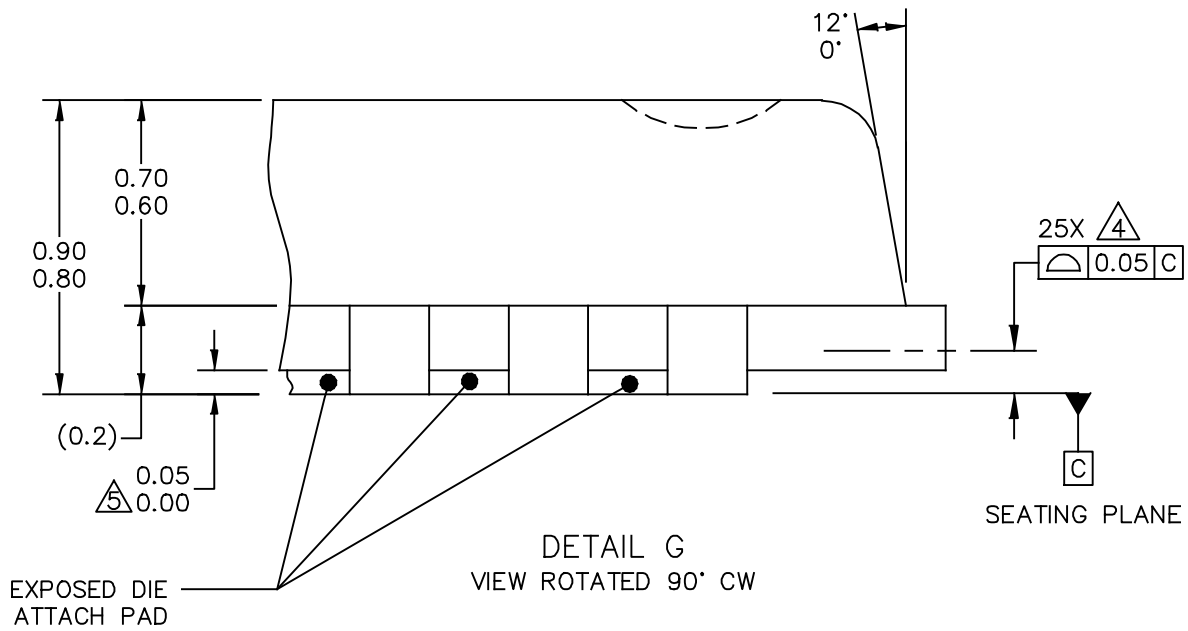

Figure 22. Product Marking

PACKAGE DIMENSIONS



© NXP SEMICONDUCTORS N.V. ALL RIGHTS RESERVED	MECHANICAL OUTLINE	PRINT VERSION NOT TO SCALE
TITLE: QFN (PUNCH), THERMALLY ENHANCED 4 X 4 X 0.85, 0.5 PITCH, 24 TERMINAL		DOCUMENT NO: 98ASA00462D REV: A STANDARD: NON-JEDEC SOT616-7 12 JAN 2016



© NXP SEMICONDUCTORS N.V. ALL RIGHTS RESERVED	MECHANICAL OUTLINE	PRINT VERSION NOT TO SCALE
TITLE: QFN (PUNCH), THERMALLY ENHANCED 4 X 4 X 0.85, 0.5 PITCH, 24 TERMINAL	DOCUMENT NO: 98ASA00462D	REV: A
	STANDARD: NON-JEDEC	
	SOT616-7	12 JAN 2016

NOTES:

1. ALL DIMENSIONS ARE IN MILLIMETERS.

2. DIMENSIONING AND TOLERANCING PER ASME Y14.5M-1994.

3. THIS DIMENSION APPLIES TO METALIZED TERMINAL AND IS MEASURED BETWEEN 0.15 AND 0.30MM FROM TERMINAL TIP.

4. BILATERAL COPLANARITY ZONE APPLIES TO THE EXPOSED PAD AS WELL AS THE TERMINALS.

5. THIS DIMENSION APPLIES ONLY FOR TERMINALS.

© NXP SEMICONDUCTORS N.V. ALL RIGHTS RESERVED	MECHANICAL OUTLINE	PRINT VERSION NOT TO SCALE	
TITLE: QFN (PUNCH), THERMALLY ENHANCED 4 X 4 X 0.85, 0.5 PITCH, 24 TERMINAL		DOCUMENT NO: 98ASA00462D	REV: A
		STANDARD: NON-JEDEC	
		SOT616-7	12 JAN 2016

PRODUCT DOCUMENTATION, SOFTWARE AND TOOLS

Refer to the following resources to aid your design process.

Application Notes

- AN1955: Thermal Measurement Methodology of RF Power Amplifiers

Software

- .s2p File

Development Tools

- Printed Circuit Boards

To Download Resources Specific to a Given Part Number:

1. Go to <http://www.nxp.com/RF>
2. Search by part number
3. Click part number link
4. Choose the desired resource from the drop down menu

FAILURE ANALYSIS

At this time, because of the physical characteristics of the part, failure analysis is limited to electrical signature analysis. In cases where NXP is contractually obligated to perform failure analysis (FA) services, full FA may be performed by third party vendors with moderate success. For updates contact your local NXP Sales Office.

REVISION HISTORY

The following table summarizes revisions to this document.

Revision	Date	Description
0	Jan. 2016	<ul style="list-style-type: none">• Initial Release of Data Sheet
1	Feb. 2017	<ul style="list-style-type: none">• Figure 1, Pin Connections: corrected V_{CC1}/RF_{out1} connection, p. 1• Table 6, Ordering Information: added to data sheet, p. 2• Figures 4, 13, Test Circuit Component Layouts: added V_{BIAS} footnote, pp. 5, 9• Figures 8, 9, 10, 11, performance graphs: LTE 20 MHz corrected to remove minus sign; TM1 signal corrected to TM1.1, p. 7• Figure 22, Product Marking: updated to show location of Pin 1 on Product Marking, p. 12

How to Reach Us:

Home Page:
nxp.com

Web Support:
nxp.com/support

Information in this document is provided solely to enable system and software implementers to use NXP products. There are no express or implied copyright licenses granted hereunder to design or fabricate any integrated circuits based on the information in this document. NXP reserves the right to make changes without further notice to any products herein.

NXP makes no warranty, representation, or guarantee regarding the suitability of its products for any particular purpose, nor does NXP assume any liability arising out of the application or use of any product or circuit, and specifically disclaims any and all liability, including without limitation consequential or incidental damages. "Typical" parameters that may be provided in NXP data sheets and/or specifications can and do vary in different applications, and actual performance may vary over time. All operating parameters, including "typicals," must be validated for each customer application by customer's technical experts. NXP does not convey any license under its patent rights nor the rights of others. NXP sells products pursuant to standard terms and conditions of sale, which can be found at the following address: nxp.com/SalesTermsandConditions.

NXP, the NXP logo, Freescale, and the Freescale logo are trademarks of NXP B.V. All other product or service names are the property of their respective owners.
© 2016–2017 NXP B.V.





Компания «ЭлектроПласт» предлагает заключение долгосрочных отношений при поставках импортных электронных компонентов на взаимовыгодных условиях!

Наши преимущества:

- Оперативные поставки широкого спектра электронных компонентов отечественного и импортного производства напрямую от производителей и с крупнейших мировых складов;
- Поставка более 17-ти миллионов наименований электронных компонентов;
- Поставка сложных, дефицитных, либо снятых с производства позиций;
- Оперативные сроки поставки под заказ (от 5 рабочих дней);
- Экспресс доставка в любую точку России;
- Техническая поддержка проекта, помощь в подборе аналогов, поставка прототипов;
- Система менеджмента качества сертифицирована по Международному стандарту ISO 9001;
- Лицензия ФСБ на осуществление работ с использованием сведений, составляющих государственную тайну;
- Поставка специализированных компонентов (Xilinx, Altera, Analog Devices, Intersil, Interpoint, Microsemi, Aeroflex, Peregrine, Syfer, Eurofarad, Texas Instrument, Miteq, Cobham, E2V, MA-COM, Hittite, Mini-Circuits, General Dynamics и др.);

Помимо этого, одним из направлений компании «ЭлектроПласт» является направление «Источники питания». Мы предлагаем Вам помощь Конструкторского отдела:

- Подбор оптимального решения, техническое обоснование при выборе компонента;
- Подбор аналогов;
- Консультации по применению компонента;
- Поставка образцов и прототипов;
- Техническая поддержка проекта;
- Защита от снятия компонента с производства.



Как с нами связаться

Телефон: 8 (812) 309 58 32 (многоканальный)

Факс: 8 (812) 320-02-42

Электронная почта: org@eplast1.ru

Адрес: 198099, г. Санкт-Петербург, ул. Калинина, дом 2, корпус 4, литера А.