

240-MHz 32-bit RX MCU, on-chip FPU, 480 DMIPS, up to 4-MB flash memory, 512-KB SRAM, various communications interfaces including IEEE 1588-compliant Ethernet MAC, high-speed USB 2.0 with battery charging, SD host interface (optional), quad SPI, and CAN, 12-bit A/D converter, RTC, encryption (optional), serial interface for audio, CMOS camera interface

Features

■ 32-bit RXv2 CPU core

- Max. operating frequency: 240 MHz
Capable of 480 DMIPS in operation at 240 MHz
- Single precision 32-bit IEEE-754 floating point
- Two types of multiply-and-accumulation unit (between memories and between registers)
- 32-bit multiplier (fastest instruction execution takes one CPU clock cycle)
- Divider (fastest instruction execution takes two CPU clock cycles)
- Fast interrupt
- CISC Harvard architecture with 5-stage pipeline
- Variable-length instructions: Ultra-compact code
- Supports the memory protection unit (MPU)
- JTAG and FINE (one-line) debugging interfaces

■ Low-power design and architecture

- Operation from a single 2.7- to 3.6-V supply
- Low power consumption: A product that supports all peripheral functions draws only 0.2mA/MHz (Typ.).
- RTC is capable of operation from a dedicated power supply.
- Four low-power modes

■ On-chip code flash memory

- Supports versions with up to 4 Mbytes of ROM
- No wait states at up to 120 MHz or when the AFU is hit, one wait state at above 120 MHz and when the AFU is missed
- User code is programmable by on-board or off-board programming.
- Programming/erasing as background operations (BGOs)

■ On-chip data flash memory

- 64 Kbytes, reprogrammable up to 100,000 times
- Programming/erasing as background operations (BGOs)

■ On-chip SRAM

- 512 Kbytes of SRAM (no wait states except in the 256 Kbytes from 0004 0000h to 0007 FFFFh when ICLK is set to 120 MHz or faster)
- 32 Kbytes of RAM with ECC (single-error correction and double error detection)
- 8 Kbytes of standby RAM (backup on deep software standby)

■ Data transfer

- DMAC: 8 channels
- DTC
- EXDMAC: 2 channels
- DMAC for the Ethernet controller: 3 channels for 176- and 177-pin products; 2 channels for 100-, 144-, and 145-pin products

■ Reset and supply management

- Power-on reset (POR)
- Low voltage detection (LVD) with voltage settings

■ Clock functions

- External crystal resonator or internal PLL for operation at 8 to 24 MHz
- Internal 240-kHz LOCO and HOCO selectable from 16, 18, and 20 MHz
- 120-kHz clock for the IWDTa

■ Real-time clock

- Adjustment functions (30 seconds, leap year, and error)
- Real-time clock counting and binary counting modes are selectable
- Time capture function
(for capturing times in response to event-signal input)

■ Independent watchdog timer

- 120-kHz (1/2 LOCO frequency) clock operation

■ Useful functions for IEC60730 compliance

- Oscillation-stoppage detection, frequency measurement, CRC, IWDTa, self-diagnostic function for the A/D converter, etc.
- Register write protection function can protect values in important registers against overwriting.



■ Various communications interfaces

- IEEE 1588-compliant Ethernet MAC
(for 176- and 177-pin products: 2 modules)
- PHY layer for host/function or OTG controller (1) with high-speed USB 2.0 with battery charging transfer (only for 176- and 177-pin products)
- PHY layer (1) for host/function or OTG controller (1) with full-speed USB 2.0 transfer
- CAN (compliant with ISO11898-1), incorporating 32 mailboxes (up to 3 modules)
- SCIG and SCIH with multiple functionalities (up to 9)
Choose from among asynchronous mode, clock-synchronous mode, smart-card interface mode, simplified SPI, simplified I²C, and extended serial mode.
- SCIFA with 16-byte transmission and reception FIFOs (up to 4 interfaces)
- I²C bus interface for transfer at up to 1 Mbps (up to 2 interfaces)
- Four-wire QSPI (1 interface) in addition to RSPiA (2 interfaces)
- Parallel data capture unit (PDC) for the CMOS camera interface (not in 100-pin products)
- SD host interface (optional: 1 interface) with a 1- or 4-bit SD bus for use with SD memory or SDIO
- MMCIF with 1-, 4-, or 8-bit transfer bus width

■ External address space

- Buses for full-speed data transfer (max. operating frequency of 60 MHz)
- 8 CS areas
- 8-, 16-, or 32-bit bus space is selectable per area
- Independent SDRAM area (128 Mbytes)

■ Up to 29 extended-function timers

- 16-bit TPUa, MTU3a, and GPTA: input capture, output compare, PWM waveform output
- 8-bit TMRa (4 channels), 16-bit CMT (4 channels), 32-bit CMTW (2 channels)

■ 12-bit A/D converter

- Two 12-bit units (8 channels for unit 0; 21 channels for unit 1)
- Self diagnosis
- Detection of analog input disconnection

■ 12-bit D/A converter: 2 channels

- On-chip operational amplifier output or direct input selectable

■ Temperature sensor for measuring temperature within the chip

■ Encryption (optional)

- AES (key lengths: 128, 192, and 256 bits)
- DES (key lengths: 56 bits (DES); 3 × 56 bits (T-DES))
- SHA (SHA-1 (128), SHA-2 (224 or 256), HMAC (160, 224, or 256))

■ Up to 127 pins for general I/O ports

- 5-V tolerance, open drain, input pull-up, switchable driving ability

■ Operating temp. range

- -40°C to +85°C

1. Overview

1.1 Outline of Specifications

Table 1.1 lists the specifications in outline, and Table 1.2 gives a comparison of the functions of products in different packages.

Table 1.1 shows the outline of maximum specifications, and the number of peripheral module channels differs depending on the pin number on the package and the code flash memory capacity. For details, see Table 1.2, Comparison of Functions for Different Packages.

Table 1.1 Outline of Specifications (1/9)

Classification	Module/Function	Description
CPU	CPU	<ul style="list-style-type: none"> Maximum operating frequency: 240 MHz 32-bit RX CPU (RXv2) Minimum instruction execution time: One instruction per state (cycle of the system clock) Address space: 4-Gbyte linear Register set of the CPU <ul style="list-style-type: none"> General purpose: Sixteen 32-bit registers Control: Ten 32-bit registers Accumulator: Two 72-bit registers Basic instructions: 75 Floating-point instructions: 11 DSP instructions: 23 Addressing modes: 11 Data arrangement <ul style="list-style-type: none"> Instructions: Little endian Data: Selectable as little endian or big endian On-chip 32-bit multiplier: 32 × 32 → 64 bits On-chip divider: 32 / 32 → 32 bits Barrel shifter: 32 bits
	FPU	<ul style="list-style-type: none"> Single precision (32-bit) floating point Data types and floating-point exceptions in conformance with the IEEE754 standard
Memory	Code flash memory	<ul style="list-style-type: none"> Capacity: 2 Mbytes, 2.5 Mbytes, 3 Mbytes, 4 Mbytes No-wait access at up to 120 MHz, single wait access at frequencies above 120 MHz No-wait access to instructions and operands when the AFU is hit in operation at 240 MHz On-board programming: Four types Off-board programming (parallel programmer mode) The trusted memory (TM) function protects against the reading of programs from blocks 8 and 9.
	Data flash memory	<ul style="list-style-type: none"> Capacity: 64 Kbytes Programming/erasing: 100,000 times
	RAM	<ul style="list-style-type: none"> Capacity: 512 Kbytes 0000 0000h to 0003 FFFFh (256 Kbytes): 240 MHz No-wait access 0004 0000h to 0007 FFFFh (256 Kbytes): No-wait access at up to 120 MHz, single wait access at frequencies above 120 MHz SED (single error detection)
	Unique ID	<ul style="list-style-type: none"> 12-byte length ID unique to the device
	RAM with ECC (ECCRAM)	<ul style="list-style-type: none"> Capacity: 32 Kbytes Single wait access at up to 120 MHz, two wait accesses for reading and three wait accesses for writing at frequencies above 120 MHz SEC-DED (single error correction/double error detection)
	Standby RAM	<ul style="list-style-type: none"> Capacity: 8 Kbytes Operation synchronized with PCLKB: Up to 60 MHz, two-cycle access

Table 1.1 Outline of Specifications (2/9)

Classification	Module/Function	Description
Operating modes		<ul style="list-style-type: none"> Operating modes by the mode-setting pins at the time of release from the reset state <ul style="list-style-type: none"> Single-chip mode Boot mode (for the SCI interface) Boot mode (for the USB interface) User boot mode Selection of operating mode by register setting <ul style="list-style-type: none"> Single-chip mode, user boot mode On-chip ROM disabled extended mode On-chip ROM enabled extended mode Endian selectable
Clock	Clock generation circuit	<ul style="list-style-type: none"> Main clock oscillator, sub clock oscillator, low-speed/high-speed on-chip oscillator, PLL frequency synthesizer, and IWDI-dedicated on-chip oscillator The peripheral module clocks can be set to frequencies above that of the system clock. Main-clock oscillation stoppage detection Separate frequency-division and multiplication settings for the system clock (ICLK), peripheral module clocks (PCLKA, PCLKB, PCLKC, PCLKD), flash-IF clock (FCLK) and external bus clock (BCLK) The CPU and other bus masters run in synchronization with the system clock (ICLK): <ul style="list-style-type: none"> Up to 240 MHz Peripheral modules of MTU3, GPT, RSPI, SCIFA, USBA, ETHERC, EPTPC, EDMAC, and AES run in synchronization with PCLKA, which operates at up to 120 MHz. Other peripheral modules run in synchronization with PCLKB: Up to 60 MHz ADCLK in the SD12AD (unit 0) runs in synchronization with PCLKC: Up to 60 MHz ADCLK in the SD12AD (unit 1) runs in synchronization with PCLKD: Up to 60 MHz Flash IF run in synchronization with the flash-IF clock (FCLK): Up to 60 MHz Devices connected to the external bus run in synchronization with the external bus clock (BCLK): Up to 60 MHz Multiplication is possible with using the high-speed on-chip oscillator (HOCO) as a reference clock of the PLL circuit
Reset		<p>Nine types of reset</p> <ul style="list-style-type: none"> RES# pin reset: Generated when the RES# pin is driven low. Power-on reset: Generated when the RES# pin is driven high and VCC = AVCC0 = AVCC1 rises. Voltage-monitoring 0 reset: Generated when VCC = AVCC0 = AVCC1 falls. Voltage-monitoring 1 reset: Generated when VCC = AVCC0 = AVCC1 falls. Voltage-monitoring 2 reset: Generated when VCC = AVCC0 = AVCC1 falls. Deep software standby reset: Generated in response to an interrupt to trigger release from deep software standby. Independent watchdog timer reset: Generated when the independent watchdog timer underflows, or a refresh error occurs. Watchdog timer reset: Generated when the watchdog timer underflows, or a refresh error occurs. Software reset: Generated by register setting.
Power-on reset		<p>If the RES# pin is at the high level when power is supplied, an internal reset is generated. After VCC = AVCC0 = AVCC1 has exceeded the voltage detection level and the specified period has elapsed, the reset is cancelled.</p>
Voltage detection circuit (LVDA)		<p>Monitors the voltage being input to the VCC = AVCC0 = AVCC1 pins and generates an internal reset or internal interrupt.</p> <ul style="list-style-type: none"> Voltage detection circuit 0 <ul style="list-style-type: none"> Capable of generating an internal reset The option-setting memory can be used to select enabling or disabling of the reset. Voltage detection level: Selectable from three different levels (2.94 V, 2.87 V, and 2.80 V) Voltage detection circuits 1 and 2 <ul style="list-style-type: none"> Voltage detection level: Selectable from three different levels (2.99 V, 2.92 V, and 2.85 V) Digital filtering (1/2, 1/4, 1/8, and 1/16 LOCO frequency) Capable of generating an internal reset Two types of timing are selectable for release from reset <ul style="list-style-type: none"> An internal interrupt can be requested. Detection of voltage rising above and falling below thresholds is selectable. Maskable or non-maskable interrupt is selectable Voltage detection monitoring Event linking

Table 1.1 Outline of Specifications (3/9)

Classification	Module/Function	Description
Low power consumption	Low power consumption facilities	<ul style="list-style-type: none"> Module stop function Four low power consumption modes Sleep mode, all-module clock stop mode, software standby mode, and deep software standby mode
	Battery backup function	<ul style="list-style-type: none"> When the voltage on the VCC pin drops, battery power from the VBATT pin is supplied to keep the real-time clock (RTC) operating.
Interrupt	Interrupt controller (ICUA)	<ul style="list-style-type: none"> Peripheral function interrupts: 298 sources External interrupts: 16 (pins IRQ0 to IRQ15) Software interrupts: 2 sources Non-maskable interrupts: 7 sources Sixteen levels specifiable for the order of priority Method of interrupt source selection: The interrupt vectors consist of 256 vectors (128 sources are fixed. The remaining 128 vectors are selected from among the other 157 sources.)
External bus extension		<ul style="list-style-type: none"> The external address space can be divided into eight areas (CS0 to CS7), each with independent control of access settings. Capacity of each area: 16 Mbytes (CS0 to CS7) A chip-select signal (CS0# to CS7#) can be output for each area. Each area is specifiable as an 8-, 16-, or 32-bit bus space. The data arrangement in each area is selectable as little or big endian (only for data). SDRAM interface connectable Bus format: Separate bus, multiplex bus Wait control Write buffer facility
DMA	DMA controller (DMACa)	<ul style="list-style-type: none"> 8 channels Three transfer modes: Normal transfer, repeat transfer, and block transfer Request sources: Software trigger, external interrupts, and interrupt requests from peripheral functions
	EXDMA controller (EXDMACa)	<ul style="list-style-type: none"> 2 channels Four transfer modes: Normal transfer, repeat transfer, block transfer, and cluster transfer Single-address transfer enabled with the EDACKn signal Request sources: Software trigger, external DMA requests (EDREQn), and interrupt requests from peripheral functions
	Data transfer controller (DTCa)	<ul style="list-style-type: none"> Three transfer modes: Normal transfer, repeat transfer, and block transfer Request sources: External interrupts and interrupt requests from peripheral functions
I/O ports	Programmable I/O ports	<ul style="list-style-type: none"> I/O ports for the 177-pin TFLGA, 176-pin LFBGA, and 176-pin LFQFP I/O pins: 127 Input pin: 1 Pull-up resistors: 127 Open-drain outputs: 127 5-V tolerance: 19 I/O ports for the 145-pin TFLGA and 144-pin LFQFP I/O pins: 111 Input pin: 1 Pull-up resistors: 111 Open-drain outputs: 111 5-V tolerance: 18 I/O ports for the 100-pin TFLGA and 100-pin LFQFP I/O pins: 78 Input pin: 1 Pull-up resistors: 78 Open-drain outputs: 78 5-V tolerance: 17

Table 1.1 Outline of Specifications (4/9)

Classification	Module/Function	Description
	Event link controller (ELC)	<ul style="list-style-type: none"> Event signals such as interrupt request signals can be interlinked with the operation of functions such as timer counting, eliminating the need for intervention by the CPU to control the functions. 119 internal event signals can be freely combined for interlinked operation with connected functions. Event signals from peripheral modules can be used to change the states of output pins (of ports B and E). Changes in the states of pins (of ports B and E) being used as inputs can be interlinked with the operation of peripheral modules.
Timers	16-bit timer pulse unit (TPUa)	<ul style="list-style-type: none"> (16 bits × 6 channels) × 1 unit Maximum of 16 pulse-input/output possible Select from among seven or eight counter-input clock signals for each channel Input capture/output compare function Output of PWM waveforms in up to 15 phases in PWM mode Support for buffered operation, phase-counting mode (two phase encoder input) and cascade-connected operation (32 bits × 2 channels) depending on the channel. PPG output trigger can be generated Capable of generating conversion start triggers for the A/D converters Digital filtering of signals from the input capture pins Event linking by the ELC
	Multifunction timer pulse unit (MTU3a)	<ul style="list-style-type: none"> 9 channels (16 bits × 8 channels, 32 bits × 1 channel) Maximum of 28 pulse-input/output and 3 pulse-input possible Select from among 14 counter-input clock signals for each channel (PCLKA/1, PCLKA/2, PCLKA/4, PCLKA/8, PCLKA/16, PCLKA/32, PCLKA/64, PCLKA/256, PCLKA/1024, MTCLKA, MTCLKB, MTCLKC, MTCLKD, MTIOC1A) 14 of the signals are available for channel 0, 12 are available for channel 2, 11 are available for channels 1, 3, 4, 6 to 8, and 10 are available for channel 5. Input capture function 39 output compare/input capture registers Counter clear operation (synchronous clearing by compare match/input capture) Simultaneous writing to multiple timer counters (TCNT) Simultaneous register input/output by synchronous counter operation Buffered operation Support for cascade-connected operation 43 interrupt sources Automatic transfer of register data Pulse output mode Toggle/PWM/complementary PWM/reset-synchronized PWM Complementary PWM output mode Outputs non-overlapping waveforms for controlling 3-phase inverters Automatic specification of dead times PWM duty cycle: Selectable as any value from 0% to 100% Delay can be applied to requests for A/D conversion. Non-generation of interrupt requests at peak or trough values of counters can be selected. Double buffer configuration Reset synchronous PWM mode Three phases of positive and negative PWM waveforms can be output with desired duty cycles. Phase-counting mode: 16-bit mode (channels 1 and 2); 32-bit mode (channels 1 and 2) Counter functionality for dead-time compensation Generation of triggers for A/D converter conversion A/D converter start triggers can be skipped Digital filter function for signals on the input capture and external counter clock pins PPG output trigger can be generated Event linking by the ELC
	Port output enable 3 (POE3a)	<ul style="list-style-type: none"> Control of the high-impedance state of the MTU3/GPT's waveform output pins 5 pins for input from signal sources: POE0, POE4, POE8, POE10, POE11 Initiation on detection of short-circuited outputs (detection of simultaneous PWM output to the active level) Initiation by oscillation-stoppage detection or software Additional programming of output control target pins is enabled

Table 1.1 Outline of Specifications (5/9)

Classification	Module/Function	Description
Timers	General PWM timer (GPTA)	<ul style="list-style-type: none"> • 16 bits × 4 channels • Counting up or down (saw-wave), counting up and down (triangle-wave) selectable for all channels • Four clock sources independently selectable for all channels (PCLKA/1, PCLKA/4, PCLKA/8, PCLKA/16) • 2 input/output pins per channel • 2 output compare/input capture registers per channel • For the 2 output compare/input capture registers of each channel, 4 registers are provided as buffer registers and are capable of operating as comparison registers when buffering is not in use. • In output compare operation, buffer switching can be at peaks or troughs, enabling the generation of laterally asymmetrically PWM waveforms. • Registers for setting up frame intervals on each channel (with capability for generating interrupts on overflow or underflow) • Synchronizable operation of the several counters • Modes of synchronized operation (synchronized, or displaced by desired times for phase shifting) • Generation of dead times in PWM operation • Through combination of three counters, generation of automatic three-phase PWM waveforms incorporating dead times • Starting, clearing, and stopping counters in response to external or internal triggers • Internal trigger sources: output of the internal comparator detection, software, and compare-match • Digital filter function for signals on the input capture and external trigger pins • Event linking by the ELC
	Programmable pulse generator (PPG)	<ul style="list-style-type: none"> • (4 bits × 4 groups) × 2 units • Pulse output with the MTU or TPU output as a trigger • Maximum of 32 pulse-output possible
	8-bit timers (TMRb)	<ul style="list-style-type: none"> • (8 bits × 2 channels) × 2 units • Select from among seven internal clock signals (PCLKB/1, PCLKB/2, PCLKB/8, PCLKB/32, PCLKB/64, PCLKB/1024, PCLKB/8192) and one external clock signal • Capable of output of pulse trains with desired duty cycles or of PWM signals • The 2 channels of each unit can be cascaded to create a 16-bit timer • Generation of triggers for A/D converter conversion • Capable of generating baud-rate clocks for SCI5, SCI6, and SCI12 • Event linking by the ELC
	Compare match timer (CMT)	<ul style="list-style-type: none"> • (16 bits × 2 channels) × 2 units • Select from among four internal clock signals (PCLKB/8, PCLKB/32, PCLKB/128, PCLKB/512) • Event linking by the ELC
	Compare match timer W (CMTW)	<ul style="list-style-type: none"> • (32 bits × 1 channel) × 2 units • Compare-match, input-capture input, and output-comparison output are available. • Select from among four internal clock signals (PCLKB/8, PCLKB/32, PCLKB/128, PCLKB/512) • Interrupt requests can be output in response to compare-match, input-capture, and output-comparison events. • Event linking by the ELC
	Realtime clock (RTCd)	<ul style="list-style-type: none"> • Clock sources: Main clock, sub clock • Selection of the 32-bit binary count in time count/second unit possible • Clock and calendar functions • Interrupt sources: Alarm interrupt, periodic interrupt, and carry interrupt • Battery backup operation • Time-capture facility for three values • Event linking by the ELC
	Watchdog timer (WDTA)	<ul style="list-style-type: none"> • 14 bits × 1 channel • Select from among 6 counter-input clock signals (PCLKB/4, PCLKB/64, PCLKB/128, PCLKB/512, PCLKB/2048, PCLKB/8192)

Table 1.1 Outline of Specifications (6/9)

Classification	Module/Function	Description
Timers	Independent watchdog timer (IWDTa)	<ul style="list-style-type: none"> • 14 bits × 1 channel • Counter-input clock: IWDT-dedicated on-chip oscillator • Dedicated clock/1, dedicated clock/16, dedicated clock/32, dedicated clock/64, dedicated clock/128, dedicated clock/256 • Window function: The positions where the window starts and ends are specifiable (the window defines the timing with which refreshing is enabled and disabled). • Event linking by the ELC
Communication function	Ethernet controller (ETHERC)	<ul style="list-style-type: none"> • 2 channels • Input and output of Ethernet/IEEE 802.3 frames • Transfer at 10 or 100 Mbps • Full- and half-duplex modes • MII (Media Independent Interface) or RMII (Reduced Media Independent Interface) as defined in IEEE 802.3u • Detection of Magic Packets^{TM*1} or output of a “wake-on-LAN” signal (WOL) • Compliance with flow control as defined in IEEE 802.3x standards • Filtering of multicast frames • Direct transfer of frames between two channels by cut-through
	PTP controller for Ethernet controller (EPTPCa)	<ul style="list-style-type: none"> • A block compatible with the IEEE 1588 standard is connected to the Ethernet controller (ETHERC). • Matching with a time stamp can start counting by MTU3 and the GPT.
	DMA controller for Ethernet controller (EDMACa)	<ul style="list-style-type: none"> • 3 channels (the round-robin method determines the priority of the channels) 2 channels for ETHERC; 1 channel for EPTPC • Alleviation of CPU load by the descriptor control method • Transmission FIFO: 2 Kbytes; Reception FIFO: 4 Kbytes
	USB 2.0 FS host/function module (USBb)	<ul style="list-style-type: none"> • Includes a UDC (USB Device Controller) and transceiver for USB 2.0 FS • One port • Compliance with the USB 2.0 specification • Transfer rate: Full speed (12 Mbps), low speed (1.5 Mbps) (host only) • Self-power mode and bus power are selectable • OTG (On the Go) operation is possible (low-speed is not supported) • Incorporates 2 Kbytes of RAM as a transfer buffer • External pull-up and pull-down resistors are not required
	USB 2.0 HS host/function module with battery charging (USBAA)	<ul style="list-style-type: none"> • Includes a UDC (USB Device Controller) and transceiver for USB 2.0 HS • One port (only in 177-/176-pin devices) • Compliance with the USB 2.0 specification • Transfer rate: High speed (480 Mbps), full speed (12 Mbps), low speed (1.5 Mbps) (host only) • Self-power mode and bus power are selectable • OTG (On the Go) operation is possible (low-speed is not supported) • Incorporates 8.5 Kbytes of RAM as a transfer buffer • External pull-up and pull-down resistors are not required
Serial communications interfaces (SCIg, SCIH)	<ul style="list-style-type: none"> • 9 channels (SCIg: 8 channels + SCIH: 1 channel) • SCIg <ul style="list-style-type: none"> Serial communications modes: Asynchronous, clock synchronous, and smart-card interface Multi-processor function On-chip baud rate generator allows selection of the desired bit rate Choice of LSB-first or MSB-first transfer Average transfer rate clock can be input from TMR timers for SCI5, SCI6, and SCI12 Start-bit detection: Level or edge detection is selectable. Simple I²C Simple SPI 9-bit transfer mode Bit rate modulation Double-speed mode Event linking by the ELC (supported by SCI5 only) • SCIH (The following functions are added to SCIg) <ul style="list-style-type: none"> Supports the serial communications protocol, which contains the start frame and information frame Supports the LIN format 	

Table 1.1 Outline of Specifications (7/9)

Classification	Module/Function	Description
Communication function	Serial communications interface with FIFO (SCIFA)	<ul style="list-style-type: none"> • 4 channels • Methods of transfer: Asynchronous and clock synchronous • Desired bit rates can be selected from the internal baud rate generators. • LSB or MSB first is selectable. • Both the transmission and reception sections are equipped with 16-byte FIFO buffers, allowing continuous transmission and reception. • Bit rate modulation • Double-speed mode
	I ² C bus interface (RIICa)	<ul style="list-style-type: none"> • 2 channels (only channel 0 can be used in fast-mode plus) • Communication formats I²C bus format/SMBus format • Supports the multi-master • Max. transfer rate: 1 Mbps (channel 0) • Event linking by the ELC
	CAN module (CAN)	<ul style="list-style-type: none"> • 3 channels • Compliance with the ISO11898-1 specification (standard frame and extended frame) • 32 mailboxes per channel
	Serial peripheral interface (RSPIa)	<ul style="list-style-type: none"> • 2 channels • RSPI transfer facility Using the MOSI (master out, slave in), MISO (master in, slave out), SSL (slave select), and RSPCK (RSPI clock) signals enables serial transfer through SPI operation (four lines) or clock-synchronous operation (three lines) Capable of handling serial transfer as a master or slave • Data formats Switching between MSB first and LSB first The number of bits in each transfer can be changed to any number of bits from 8 to 16, or to 20, 24, or 32 bits. 128-bit buffers for transmission and reception Up to four frames can be transmitted or received in a single transfer operation (with each frame having up to 32 bits) • Buffered structure Double buffers for both transmission and reception • RSPCK can be stopped with the receive buffer full for master reception. • Event linking by the ELC
	Quad serial peripheral interface (QSPI)	<ul style="list-style-type: none"> • 1 channel • Connectable with serial flash memory equipped with multiple input and output lines (i.e. for single, dual, or quad operation) • Programmable bit length and selectable active sense and phase of the clock signal • Sequential execution of transfer • LSB or MSB first is selectable.
Serial sound interface (SSI)	<ul style="list-style-type: none"> • 2 channels • Full-duplex transfer is possible (only on channel 0). • Support for multiple audio formats • Support for master or slave operation • Bit clock frequency is selectable from four different types (16 fs, 32 fs, 48 fs, and 64 fs). • Support for 8-/16-/18-/20-/22-/24 bit data formats • Internal 8-stage FIFO for transmission and reception • Stopping SSIWS when data transfer is stopped is selectable. 	
Sampling rate converter (SRC)	<ul style="list-style-type: none"> • 1 channel • Data formats: 32-bit stereo (16 bits for the left, 16 bits for the right) and 16-bit monaural. • Input sampling rates: 8, 11.025, 12, 16, 22.05, 24, 32, 44.1, 48 kHz • Output sampling rates: 32, 44.1, 48, 8*2 or 16 kHz*2 	
SD host interface (SDHI)*4	<ul style="list-style-type: none"> • 1 channel • Transfer speed: Supports high-speed mode (15 MB/s) and default speed mode (10 MB/s) • One interface for SD memory and I/O cards (supporting 1- and 4-bit SD buses) • SD specifications Part 1: Physical Layer Specification Ver. 3.01 compliant (DDR not supported) Part E1: SDIO Specification Ver. 3.00 • Error checking: CRC7 for commands and CRC16 for data • Interrupt requests: Card access interrupt, SDIO access interrupt, card detection interrupt • DMA transfer requests: SD_BUF write and SD_BUF read • Support for card detection and write protection 	

Table 1.1 Outline of Specifications (8/9)

Classification	Module/Function	Description
	MMC host interface (MMCIF)	<ul style="list-style-type: none"> • 1 channel • Transfer speed: Supports high-speed mode (30 MB/s) and Backward-compatible mode (25 MB/s) • Compliant with JEDEC STANDARD JESD84-A441 (DDR is not supported) • Interface for Multimedia Cards (MMCs) • Device buses: Support for 1-, 4-, and 8-bit MMC buses • Interrupt requests: Card detection interrupt, error/timeout interrupt, normal operation interrupt • DMA transfer requests: CE_DATA write and CE_DATA read • Support for card detection, boot operation, high priority interrupt (HPI)
	Parallel data capture unit (PDC)	<ul style="list-style-type: none"> • 1 channel • Acquisition of synchronization through external 8-bit horizontal and vertical synchronization signals • Setting of the image size when clipping of the output for a one-frame image is required
	12-bit A/D converter (S12ADC)	<ul style="list-style-type: none"> • 12 bits × 2 units (unit 0: 8 channels; unit 1: 21 channels) • 12-bit resolution (switchable between 8, 10, and 12 bits) • Conversion time <ul style="list-style-type: none"> 0.48 μs per channel (for 12-bit conversion) 0.45 μs per channel (for 10-bit conversion) 0.42 μs per channel (for 8-bit conversion) • Operating mode <ul style="list-style-type: none"> Scan mode (single scan mode, continuous scan mode, or group scan mode) Group A priority control (only for group scan mode) • Sample-and-hold function <ul style="list-style-type: none"> Common sample-and-hold circuit included In addition, channel-dedicated sample-and-hold function (3ch: in unit 0 only) included • Sampling variable <ul style="list-style-type: none"> Sampling time can be set up for each channel. • Digital comparison <ul style="list-style-type: none"> Method: Comparison to detect voltages above or below thresholds and window comparison Measurement: Comparison of two results of conversion or comparison of a value in the comparison register and a result of conversion • Self-diagnostic function <ul style="list-style-type: none"> The self-diagnostic function internally generates three analog input voltages (unit 0: VREFL0, VREFH0 × 1/2, VREFH0; unit 1: AVSS1, AVCC1 × 1/2, AVCC1) • Double trigger mode (A/D conversion data duplicated) • Detection of analog input disconnection • Three ways to start A/D conversion <ul style="list-style-type: none"> Software trigger, timer (MTU3, GPT, TMR, TPU) trigger, external trigger • Event linking by the ELC
	12-bit D/A converter (R12DA)	<ul style="list-style-type: none"> • 2 channels • 12-bit resolution • Output voltage: 0.2 V to AVCC1 – 0.2 V (amplifier output), 0 V to AVCC1 (direct output) • Output via an amplifier or direct output can be selected. • Event linking by the ELC
	Temperature sensor	<ul style="list-style-type: none"> • 1 channel • Relative precision: ±1°C • The voltage of the temperature is converted into a digital value by the 12-bit A/D converter (unit 1).
Safety	Memory protection unit (MPU)	<ul style="list-style-type: none"> • Protection area: Eight areas (max.) can be specified in the range from 0000 0000h to FFFF FFFFh. • Minimum protection unit: 16 bytes • Reading from, writing to, and enabling the execution access can be specified for each area. • An address exception occurs when the detected access is not in the permitted area.
	Trusted Memory (TM) Function	<ul style="list-style-type: none"> • Protects against the reading of programs from blocks 8 and 9 of the code flash memory • Instruction fetching by the CPU is the only form of access to these areas when the TM function is enabled.
	Register write protection function	<ul style="list-style-type: none"> • Protects important registers from being overwritten for in case a program runs out of control.

Table 1.1 Outline of Specifications (9/9)

Classification	Module/Function	Description
Safety	CRC calculator (CRC)	<ul style="list-style-type: none"> • CRC code generation for arbitrary amounts of data in 8-bit units • Select any of three generating polynomials: $X^8 + X^2 + X + 1$, $X^{16} + X^{15} + X^2 + 1$, or $X^{16} + X^{12} + X^5 + 1$ • Generation of CRC codes for use with LSB-first or MSB-first communications is selectable
	Main clock oscillation stop function	<ul style="list-style-type: none"> • Main clock oscillation stop detection: Available
	Clock frequency accuracy measurement circuit (CAC)	<ul style="list-style-type: none"> • Monitors the clock output from the main clock oscillator, sub-clock oscillator, low- and high-speed on-chip oscillators, the PLL frequency synthesizer, IWDT-dedicated on-chip oscillator, and PCLKB, and generates interrupts when the setting range is exceeded.
	Data operation circuit (DOC)	<ul style="list-style-type: none"> • The function to compare, add, or subtract 16-bit data
Encryption function	AESa*3	<ul style="list-style-type: none"> • Key lengths: 128, 192, and 256 bits • Support for CBC, ECB, CFB, OFB, CTR, and CMAC operating modes • Speed of calculations: 128-bit key length in 22 cycles 192-bit key length in 26 cycles 256-bit key length in 30 cycles • Compliant with FIPS PUB 197
	DES*3	<ul style="list-style-type: none"> • Key lengths: 56 bits (DES)/3 × 56 bits (T-DES) • Support for DES and triple DES • Support for ECB and CBC operating modes • Speed of calculations: 6 clock cycles in single DES mode 14 clock cycles in triple DES mode • Compliant with FIPS PUB 46-3 • Compliant with FIPS PUB 81
	SHAa*3	<ul style="list-style-type: none"> • Support for SHA-1 (128), SHA-2 (224 or 256), and HMAC (160, 224, or 256) • Speed of calculations: 50 clock cycles in SHA-1 mode 42 clock cycles in SHA-224 mode 42 clock cycles in SHA-256 mode • Compliant with SHA as defined in FIPS PUB 180-1 and -2 • Compliant with HMAC as defined in FIPS PUB 198
	True random number generator (RNG)*3	<ul style="list-style-type: none"> • Length of random numbers: 16 bits • Generation of random-number-generated interrupts after a number is generated • Random number generation time: 3.6 ms (typ)
Operating frequency		Up to 240 MHz
Power supply voltage		VCC = AVCC0 = AVCC1 = VCC_USB = 2.7 to 3.6 V, $2.7 \leq VREFH0 \leq AVCC0$, VCC_USBA = AVCC_USBA = 2.7 to 3.6 V, V_BATT = 2.0 to 3.6 V
Operating temperature		D-version: -40 to +85°C G-version: -40 to +105°C (in planning)
Package		177-pin TFLGA (PTLG0177KA-A) 176-pin LFBGA (PLBG0176GA-A) 176-pin LFQFP (PLQP0176KB-A) 145-pin TFLGA (PTLG0145KA-A) 144-pin LFQFP (PLQP0144KA-A) 100-pin TFLGA (PTLG0100JA-A) 100-pin LFQFP (PLQP0100KB-A)
On-chip debugging system		<ul style="list-style-type: none"> • E1 emulator (JTAG and FINE interfaces) • E20 emulator (JTAG interface)

Note 1. Magic Packet™ is a registered trademark of Advanced Micro Devices, Inc.

Note 2. Setting is only possible when the input sampling rate 44.1 kHz is selected.

Note 3. The product part number differs according to whether or not it supports encryption.

Note 4. The product part number differs according to whether or not it includes an SDHI (SD host interface).

Table 1.2 Comparison of Functions for Different Packages (1/2)

Functions		RX71M Group		
Package		177 Pins, 176 Pins	145 Pins, 144 Pins	100 Pins
External bus	External bus width	32 bits	16 bits	
	SDRAM area controller	Available		Not supported
DMA	DMA controller	Ch. 0 to 7		
	Data transfer controller	Available		
	EXDMA controller	Ch. 0 and 1		
Timers	16-bit timer pulse unit	Ch. 0 to 5		
	Multi-function timer pulse unit 3	Ch. 0 to 8		
	General-purpose PWM timer	Ch. 0 to 3		
	Port output enable 3	Available		
	Programmable pulse generator	Ch. 0 and 1		
	8-bit timers	Ch. 0 to 3		
	Compare match timer	Ch. 0 to 3		
	Compare match timer W	Ch. 0 and 1		
	Realtime clock	Available		
	Watchdog timer	Available		
	Independent watchdog timer	Available		
Communication function	Ethernet controller	Ch. 0 and 1	Ch. 0	
	PTP controller for ethernet controller	Available		
	DMAC controller for ethernet	Ch. 0 and 1 (ETHERC) Ch. 2 (EPTPC)	Ch. 0 (ETHERC) and 2 (EPTPC)	
	USB 2.0 FS host/function module	Ch. 0		
	USB 2.0 HS host/function module with battery charging	Available	Not supported	
	Serial communications interfaces (SCIg)	Ch. 0 to 7		Ch. 0 to 3, 5 and 6
	Serial communications interfaces (SCIh)	Ch. 12		
	Serial communications interfaces with FIFO	Ch. 8 to 11		Ch. 8 and 9
	I ² C bus interfaces	Ch. 0 and 2		
	Serial peripheral interface	Ch. 0 and 1		
	CAN module	Ch. 0 to 2		Ch. 0 and 1
	Quad serial peripheral interface	Ch. 0		
	Serial sound interfaces	Ch. 0 and 1		
	Sampling rate converter	Available		
	SD host interface	Ch. 0		
	MMC host interface	Ch. 0		
	Parallel data capture unit	Available		Not supported
12-bit A/D converter	AN000 to 007 (unit 0: 8 channels) AN100 to 120 (unit 1: 21 channels)		AN000 to 007 (unit 0: 8 channels) AN100 to 113 (unit 1: 14 channels)	
12-bit D/A converter	Ch. 0 and 1		Ch. 1	
Temperature sensor	Available			
CRC calculator	Available			
Data operation circuit	Available			
Clock frequency accuracy measurement circuit	Available			
AES	Available			

Table 1.2 Comparison of Functions for Different Packages (2/2)

Functions Package	RX71M Group		
	177 Pins, 176 Pins	145 Pins, 144 Pins	100 Pins
DES	Available		
SHA	Available		
RNG	Available		
Event link controller	Available		

1.2 List of Products

Table 1.3 is a list of products, and Figure 1.1 shows how to read the product part no.

Table 1.3 List of Products (1/3)

Group	Part No.	Package	Code Flash Memory Capacity	RAM Capacity	Data Flash Memory Capacity	Operating Frequency (Max.)	Encryption Module	SDHI
RX71M	R5F571MLCDFC	PLQP0176KB-A	4 Mbytes	512 Kbytes	64 Kbytes	240 MHz	Not supported	Not supported
	R5F571MLDDFC	PLQP0176KB-A	4 Mbytes	512 Kbytes	64 Kbytes	240 MHz	Not supported	Available
	R5F571MLGDFC	PLQP0176KB-A	4 Mbytes	512 Kbytes	64 Kbytes	240 MHz	Available	Not supported
	R5F571MLHDFC	PLQP0176KB-A	4 Mbytes	512 Kbytes	64 Kbytes	240 MHz	Available	Available
	R5F571MJCDFC	PLQP0176KB-A	3 Mbytes	512 Kbytes	64 Kbytes	240 MHz	Not supported	Not supported
	R5F571MJDDFC	PLQP0176KB-A	3 Mbytes	512 Kbytes	64 Kbytes	240 MHz	Not supported	Available
	R5F571MJGDFC	PLQP0176KB-A	3 Mbytes	512 Kbytes	64 Kbytes	240 MHz	Available	Not supported
	R5F571MJHDFC	PLQP0176KB-A	3 Mbytes	512 Kbytes	64 Kbytes	240 MHz	Available	Available
	R5F571MGCDFC	PLQP0176KB-A	2.5 Mbytes	512 Kbytes	64 Kbytes	240 MHz	Not supported	Not supported
	R5F571MGDDFC	PLQP0176KB-A	2.5 Mbytes	512 Kbytes	64 Kbytes	240 MHz	Not supported	Available
	R5F571MGDFC	PLQP0176KB-A	2.5 Mbytes	512 Kbytes	64 Kbytes	240 MHz	Available	Not supported
	R5F571MGHDFC	PLQP0176KB-A	2.5 Mbytes	512 Kbytes	64 Kbytes	240 MHz	Available	Available
	R5F571MFCDFC	PLQP0176KB-A	2 Mbytes	512 Kbytes	64 Kbytes	240 MHz	Not supported	Not supported
	R5F571MFDDFC	PLQP0176KB-A	2 Mbytes	512 Kbytes	64 Kbytes	240 MHz	Not supported	Available
	R5F571MFGDFC	PLQP0176KB-A	2 Mbytes	512 Kbytes	64 Kbytes	240 MHz	Available	Not supported
	R5F571MFHDFC	PLQP0176KB-A	2 Mbytes	512 Kbytes	64 Kbytes	240 MHz	Available	Available
	R5F571MLCDFB	PLQP0144KA-A	4 Mbytes	512 Kbytes	64 Kbytes	240 MHz	Not supported	Not supported
	R5F571MLDDFB	PLQP0144KA-A	4 Mbytes	512 Kbytes	64 Kbytes	240 MHz	Not supported	Available
	R5F571MLGDFB	PLQP0144KA-A	4 Mbytes	512 Kbytes	64 Kbytes	240 MHz	Available	Not supported
	R5F571MLHDFB	PLQP0144KA-A	4 Mbytes	512 Kbytes	64 Kbytes	240 MHz	Available	Available
	R5F571MJCDFB	PLQP0144KA-A	3 Mbytes	512 Kbytes	64 Kbytes	240 MHz	Not supported	Not supported
	R5F571MJDDFB	PLQP0144KA-A	3 Mbytes	512 Kbytes	64 Kbytes	240 MHz	Not supported	Available
	R5F571MJGDFB	PLQP0144KA-A	3 Mbytes	512 Kbytes	64 Kbytes	240 MHz	Available	Not supported
	R5F571MJHDFB	PLQP0144KA-A	3 Mbytes	512 Kbytes	64 Kbytes	240 MHz	Available	Available
	R5F571MGCDFB	PLQP0144KA-A	2.5 Mbytes	512 Kbytes	64 Kbytes	240 MHz	Not supported	Not supported
	R5F571MGDDFB	PLQP0144KA-A	2.5 Mbytes	512 Kbytes	64 Kbytes	240 MHz	Not supported	Available
	R5F571MGDFB	PLQP0144KA-A	2.5 Mbytes	512 Kbytes	64 Kbytes	240 MHz	Available	Not supported
	R5F571MGHDFB	PLQP0144KA-A	2.5 Mbytes	512 Kbytes	64 Kbytes	240 MHz	Available	Available
	R5F571MFCDFB	PLQP0144KA-A	2 Mbytes	512 Kbytes	64 Kbytes	240 MHz	Not supported	Not supported
	R5F571MFDDFB	PLQP0144KA-A	2 Mbytes	512 Kbytes	64 Kbytes	240 MHz	Not supported	Available
	R5F571MFGDFB	PLQP0144KA-A	2 Mbytes	512 Kbytes	64 Kbytes	240 MHz	Available	Not supported
	R5F571MFHDFB	PLQP0144KA-A	2 Mbytes	512 Kbytes	64 Kbytes	240 MHz	Available	Available
	R5F571MLCDFP	PLQP0100KB-A	4 Mbytes	512 Kbytes	64 Kbytes	240 MHz	Not supported	Not supported
	R5F571MLDDFP	PLQP0100KB-A	4 Mbytes	512 Kbytes	64 Kbytes	240 MHz	Not supported	Available
	R5F571MLGDFP	PLQP0100KB-A	4 Mbytes	512 Kbytes	64 Kbytes	240 MHz	Available	Not supported
	R5F571MLHDFP	PLQP0100KB-A	4 Mbytes	512 Kbytes	64 Kbytes	240 MHz	Available	Available
	R5F571MJCDFP	PLQP0100KB-A	3 Mbytes	512 Kbytes	64 Kbytes	240 MHz	Not supported	Not supported
	R5F571MJDDFP	PLQP0100KB-A	3 Mbytes	512 Kbytes	64 Kbytes	240 MHz	Not supported	Available
	R5F571MJGDFP	PLQP0100KB-A	3 Mbytes	512 Kbytes	64 Kbytes	240 MHz	Available	Not supported
	R5F571MJHDFP	PLQP0100KB-A	3 Mbytes	512 Kbytes	64 Kbytes	240 MHz	Available	Available
	R5F571MGCDFP	PLQP0100KB-A	2.5 Mbytes	512 Kbytes	64 Kbytes	240 MHz	Not supported	Not supported
	R5F571MGDDFP	PLQP0100KB-A	2.5 Mbytes	512 Kbytes	64 Kbytes	240 MHz	Not supported	Available
	R5F571MGDFP	PLQP0100KB-A	2.5 Mbytes	512 Kbytes	64 Kbytes	240 MHz	Available	Not supported
	R5F571MGHDFP	PLQP0100KB-A	2.5 Mbytes	512 Kbytes	64 Kbytes	240 MHz	Available	Available

Table 1.3 List of Products (2/3)

Group	Part No.	Package	Code Flash Memory Capacity	RAM Capacity	Data Flash Memory Capacity	Operating Frequency (Max.)	Encryption Module	SDHI
RX71M	R5F571MFCDFP	PLQP0100KB-A	2 Mbytes	512 Kbytes	64 Kbytes	240 MHz	Not supported	Not supported
	R5F571MFDDFP	PLQP0100KB-A	2 Mbytes	512 Kbytes	64 Kbytes	240 MHz	Not supported	Available
	R5F571MFGDFP	PLQP0100KB-A	2 Mbytes	512 Kbytes	64 Kbytes	240 MHz	Available	Not supported
	R5F571MFHDFP	PLQP0100KB-A	2 Mbytes	512 Kbytes	64 Kbytes	240 MHz	Available	Available
	R5F571MLCDBG	PLBG0176GA-A	4 Mbytes	512 Kbytes	64 Kbytes	240 MHz	Not supported	Not supported
	R5F571MLDDBG	PLBG0176GA-A	4 Mbytes	512 Kbytes	64 Kbytes	240 MHz	Not supported	Available
	R5F571MLGDBG	PLBG0176GA-A	4 Mbytes	512 Kbytes	64 Kbytes	240 MHz	Available	Not supported
	R5F571MLHDBG	PLBG0176GA-A	4 Mbytes	512 Kbytes	64 Kbytes	240 MHz	Available	Available
	R5F571MJCDBG	PLBG0176GA-A	3 Mbytes	512 Kbytes	64 Kbytes	240 MHz	Not supported	Not supported
	R5F571MJDDBG	PLBG0176GA-A	3 Mbytes	512 Kbytes	64 Kbytes	240 MHz	Not supported	Available
	R5F571MJGDBG	PLBG0176GA-A	3 Mbytes	512 Kbytes	64 Kbytes	240 MHz	Available	Not supported
	R5F571MJHDBG	PLBG0176GA-A	3 Mbytes	512 Kbytes	64 Kbytes	240 MHz	Available	Available
	R5F571MGCDDBG	PLBG0176GA-A	2.5 Mbytes	512 Kbytes	64 Kbytes	240 MHz	Not supported	Not supported
	R5F571MGDDDBG	PLBG0176GA-A	2.5 Mbytes	512 Kbytes	64 Kbytes	240 MHz	Not supported	Available
	R5F571MGGDBG	PLBG0176GA-A	2.5 Mbytes	512 Kbytes	64 Kbytes	240 MHz	Available	Not supported
	R5F571MGHDBG	PLBG0176GA-A	2.5 Mbytes	512 Kbytes	64 Kbytes	240 MHz	Available	Available
	R5F571MFCDBG	PLBG0176GA-A	2 Mbytes	512 Kbytes	64 Kbytes	240 MHz	Not supported	Not supported
	R5F571MFDDDBG	PLBG0176GA-A	2 Mbytes	512 Kbytes	64 Kbytes	240 MHz	Not supported	Available
	R5F571MFGDBG	PLBG0176GA-A	2 Mbytes	512 Kbytes	64 Kbytes	240 MHz	Available	Not supported
	R5F571MFHDBG	PLBG0176GA-A	2 Mbytes	512 Kbytes	64 Kbytes	240 MHz	Available	Available
	R5F571MLCDLC	PTLG0177KA-A	4 Mbytes	512 Kbytes	64 Kbytes	240 MHz	Not supported	Not supported
	R5F571MLDDLC	PTLG0177KA-A	4 Mbytes	512 Kbytes	64 Kbytes	240 MHz	Not supported	Available
	R5F571MLGDLC	PTLG0177KA-A	4 Mbytes	512 Kbytes	64 Kbytes	240 MHz	Available	Not supported
	R5F571MLHDLC	PTLG0177KA-A	4 Mbytes	512 Kbytes	64 Kbytes	240 MHz	Available	Available
	R5F571MJCDLC	PTLG0177KA-A	3 Mbytes	512 Kbytes	64 Kbytes	240 MHz	Not supported	Not supported
	R5F571MJDDLC	PTLG0177KA-A	3 Mbytes	512 Kbytes	64 Kbytes	240 MHz	Not supported	Available
	R5F571MJGDLC	PTLG0177KA-A	3 Mbytes	512 Kbytes	64 Kbytes	240 MHz	Available	Not supported
	R5F571MJHDLC	PTLG0177KA-A	3 Mbytes	512 Kbytes	64 Kbytes	240 MHz	Available	Available
	R5F571MGCDLDC	PTLG0177KA-A	2.5 Mbytes	512 Kbytes	64 Kbytes	240 MHz	Not supported	Not supported
	R5F571MGDDLDC	PTLG0177KA-A	2.5 Mbytes	512 Kbytes	64 Kbytes	240 MHz	Not supported	Available
	R5F571MGDDLDC	PTLG0177KA-A	2.5 Mbytes	512 Kbytes	64 Kbytes	240 MHz	Available	Not supported
	R5F571MGHDLDC	PTLG0177KA-A	2.5 Mbytes	512 Kbytes	64 Kbytes	240 MHz	Available	Available
	R5F571MFCDLDC	PTLG0177KA-A	2 Mbytes	512 Kbytes	64 Kbytes	240 MHz	Not supported	Not supported
	R5F571MFDDLDC	PTLG0177KA-A	2 Mbytes	512 Kbytes	64 Kbytes	240 MHz	Not supported	Available
	R5F571MFGDLDC	PTLG0177KA-A	2 Mbytes	512 Kbytes	64 Kbytes	240 MHz	Available	Not supported
	R5F571MFHDLDC	PTLG0177KA-A	2 Mbytes	512 Kbytes	64 Kbytes	240 MHz	Available	Available
	R5F571MLCDLK	PTLG0145KA-A	4 Mbytes	512 Kbytes	64 Kbytes	240 MHz	Not supported	Not supported
	R5F571MLDDLK	PTLG0145KA-A	4 Mbytes	512 Kbytes	64 Kbytes	240 MHz	Not supported	Available
	R5F571MLGDLK	PTLG0145KA-A	4 Mbytes	512 Kbytes	64 Kbytes	240 MHz	Available	Not supported
	R5F571MLHDLK	PTLG0145KA-A	4 Mbytes	512 Kbytes	64 Kbytes	240 MHz	Available	Available
	R5F571MJCDLK	PTLG0145KA-A	3 Mbytes	512 Kbytes	64 Kbytes	240 MHz	Not supported	Not supported
	R5F571MJDDLK	PTLG0145KA-A	3 Mbytes	512 Kbytes	64 Kbytes	240 MHz	Not supported	Available
	R5F571MJGDLK	PTLG0145KA-A	3 Mbytes	512 Kbytes	64 Kbytes	240 MHz	Available	Not supported
	R5F571MJHDLK	PTLG0145KA-A	3 Mbytes	512 Kbytes	64 Kbytes	240 MHz	Available	Available
	R5F571MGCDLK	PTLG0145KA-A	2.5 Mbytes	512 Kbytes	64 Kbytes	240 MHz	Not supported	Not supported
	R5F571MGDDLK	PTLG0145KA-A	2.5 Mbytes	512 Kbytes	64 Kbytes	240 MHz	Not supported	Available
	R5F571MGDDLK	PTLG0145KA-A	2.5 Mbytes	512 Kbytes	64 Kbytes	240 MHz	Available	Not supported
	R5F571MGHDLK	PTLG0145KA-A	2.5 Mbytes	512 Kbytes	64 Kbytes	240 MHz	Available	Available

Table 1.3 List of Products (3/3)

Group	Part No.	Package	Code Flash Memory Capacity	RAM Capacity	Data Flash Memory Capacity	Operating Frequency (Max.)	Encryption Module	SDHI
RX71M	R5F571MFCDLK	PTLG0145KA-A	2 Mbytes	512 Kbytes	64 Kbytes	240 MHz	Not supported	Not supported
	R5F571MFDDLK	PTLG0145KA-A	2 Mbytes	512 Kbytes	64 Kbytes	240 MHz	Not supported	Available
	R5F571MFGDLK	PTLG0145KA-A	2 Mbytes	512 Kbytes	64 Kbytes	240 MHz	Available	Not supported
	R5F571MFHDLK	PTLG0145KA-A	2 Mbytes	512 Kbytes	64 Kbytes	240 MHz	Available	Available
	R5F571MLCDLJ	PTLG0100JA-A	4 Mbytes	512 Kbytes	64 Kbytes	240 MHz	Not supported	Not supported
	R5F571MLDDLJ	PTLG0100JA-A	4 Mbytes	512 Kbytes	64 Kbytes	240 MHz	Not supported	Available
	R5F571MLGDLJ	PTLG0100JA-A	4 Mbytes	512 Kbytes	64 Kbytes	240 MHz	Available	Not supported
	R5F571MLHDLJ	PTLG0100JA-A	4 Mbytes	512 Kbytes	64 Kbytes	240 MHz	Available	Available
	R5F571MJCDLJ	PTLG0100JA-A	3 Mbytes	512 Kbytes	64 Kbytes	240 MHz	Not supported	Not supported
	R5F571MJDDLJ	PTLG0100JA-A	3 Mbytes	512 Kbytes	64 Kbytes	240 MHz	Not supported	Available
	R5F571MJGDLJ	PTLG0100JA-A	3 Mbytes	512 Kbytes	64 Kbytes	240 MHz	Available	Not supported
	R5F571MJHDLJ	PTLG0100JA-A	3 Mbytes	512 Kbytes	64 Kbytes	240 MHz	Available	Available
	R5F571MGCDLJ	PTLG0100JA-A	2.5 Mbytes	512 Kbytes	64 Kbytes	240 MHz	Not supported	Not supported
	R5F571MGDDLJ	PTLG0100JA-A	2.5 Mbytes	512 Kbytes	64 Kbytes	240 MHz	Not supported	Available
	R5F571MGGDLJ	PTLG0100JA-A	2.5 Mbytes	512 Kbytes	64 Kbytes	240 MHz	Available	Not supported
	R5F571MGHDLJ	PTLG0100JA-A	2.5 Mbytes	512 Kbytes	64 Kbytes	240 MHz	Available	Available
	R5F571MFCDLJ	PTLG0100JA-A	2 Mbytes	512 Kbytes	64 Kbytes	240 MHz	Not supported	Not supported
	R5F571MFDDLJ	PTLG0100JA-A	2 Mbytes	512 Kbytes	64 Kbytes	240 MHz	Not supported	Available
	R5F571MFGDLJ	PTLG0100JA-A	2 Mbytes	512 Kbytes	64 Kbytes	240 MHz	Available	Not supported
	R5F571MFHDLJ	PTLG0100JA-A	2 Mbytes	512 Kbytes	64 Kbytes	240 MHz	Available	Available



Figure 1.1 How to Read the Product Part Number

1.3 Block Diagram

Figure 1.2 shows a block diagram.



Figure 1.2 Block Diagram

1.4 Pin Functions

Table 1.4 lists the pin functions.

Table 1.4 Pin Functions (1/8)

Classifications	Pin Name	I/O	Description
Digital power supply	VCC	Input	Power supply pin. Connect this pin to the system power supply. Connect the pin to VSS via a 0.1- μ F multilayer ceramic capacitor. The capacitor should be placed close to the pin.
	VCL	Input	Connect this pin to VSS via a 0.22- μ F capacitor. The capacitor should be placed close to the pin.
	VSS	Input	Ground pin. Connect it to the system power supply (0 V).
	VBATT	Input	Backup power pin
Clock	XTAL	Output	Pins for a crystal resonator. An external clock signal can be input through the EXTAL pin.
	EXTAL	Input	
	BCLK	Output	Outputs the external bus clock for external devices.
	SDCLK	Output	Outputs the SDRAM-dedicated clock.
	XCOUT	Output	Input/output pins for the sub clock oscillator. Connect a crystal resonator between XCOUT and XCIN.
	XCIN	Input	
Clock frequency accuracy measurement	CACREF	Input	Reference clock input pin for the clock frequency accuracy measurement circuit
Operating mode control	MD	Input	Pins for setting the operating mode. The signal levels on these pins must not be changed during operation.
	UB	Input	USB boot mode or user boot mode enable pin
	UPSEL	Input	Selects the power supply method in USB boot mode. The low level selects self-power mode and the high level selects bus power mode.
System control	RES#	Input	Reset signal input pin. This LSI enters the reset state when this signal goes low.
	EMLE	Input	Input pin for the on-chip emulator enable signal. When the on-chip emulator is used, this pin should be driven high. When not used, it should be driven low.
	BSCANP	Input	Boundary scan enable pin. Boundary scan is enabled when this pin goes high. When not used, it should be driven low.
On-chip emulator	FINED	I/O	Fine interface pin
	TRST#	Input	On-chip emulator or boundary scan pins. When the EMLE pin is driven high, these pins are dedicated for the on-chip emulator.
	TMS	Input	
	TDI	Input	
	TCK	Input	
	TDO	Output	
	TRCLK	Output	This pin outputs the clock for synchronization with the trace data.
	TRSYNC	Output	This pin indicates that output from the TRDATA0 to TRDATA3 pins is valid.
	TRDATA0 to TRDATA3	Output	These pins output the trace information.
Address bus	A0 to A23	Output	Output pins for the address
Data bus	D0 to D31	I/O	Input and output pins for the bidirectional data bus
Multiplexed bus	A0/D0 to A15/D15	I/O	Address/data multiplexed bus

Table 1.4 Pin Functions (2/8)

Classifications	Pin Name	I/O	Description
Bus control	RD#	Output	Strobe signal which indicates that reading from the external bus interface space is in progress
	WR#	Output	Strobe signal which indicates that writing to the external bus interface space is in progress, in 1-write strobe mode
	WR0# to WR3#	Output	Strobe signals which indicate that either group of data bus pins (D7 to D0, D15 to D8, D23 to D16 and D31 to D24) is valid in writing to the external bus interface space, in byte strobe mode
	BC0# to BC3#	Output	Strobe signals which indicate that either group of data bus pins (D7 to D0, D15 to D8, D23 to D16 and D31 to D24) is valid in access to the external bus interface space, in 1-write strobe mode
	ALE	Output	Address latch signal when address/data multiplexed bus is selected
	WAIT#	Input	Input pin for wait request signals in access to the external space
	CS0# to CS7#	Output	Select signals for CS areas
	CKE	Output	SDRAM clock enable signal
	SDCS#	Output	SDRAM chip select signal
	RAS#	Output	SDRAM row address strobe signal
	CAS#	Output	SDRAM column address strobe signal
	WE#	Output	SDRAM write enable pin
	DQM0 to DQM3	Output	SDRAM I/O data mask enable signals
	EXDMA controller	EDREQ0, EDREQ1	Input
EDACK0, EDACK1		Output	Single address transfer acknowledge signals
Interrupt	NMI	Input	Non-maskable interrupt request pin
	IRQ0 to IRQ15	Input	Maskable interrupt request pins
Multi-function timer pulse unit 3	MTIOC0A, MTIOC0B, MTIOC0C, MTIOC0D	I/O	The TGRA0 to TGRD0 input capture input/output compare output/PWM output pins
	MTIOC1A, MTIOC1B	I/O	The TGRA1 and TGRB1 input capture input/output compare output/PWM output pins
	MTIOC2A, MTIOC2B	I/O	The TGRA2 and TGRB2 input capture input/output compare output/PWM output pins
	MTIOC3A, MTIOC3B, MTIOC3C, MTIOC3D	I/O	The TGRA3 to TGRD3 input capture input/output compare output/PWM output pins
	MTIOC4A, MTIOC4B, MTIOC4C, MTIOC4D	I/O	The TGRA4 to TGRD4 input capture input/output compare output/PWM output pins
	MTIC5U, MTIC5V, MTIC5W	Input	The TGRU5, TGRV5, and TGRW5 input capture input/dead time compensation input pins
	MTIOC6A, MTIOC6B, MTIOC6C, MTIOC6D	I/O	The TGRA6 to TGRD6 input capture input/output compare output/PWM output pins
	MTIOC7A, MTIOC7B, MTIOC7C, MTIOC7D	I/O	The TGRA7 to TGRD7 input capture input/output compare output/PWM output pins
	MTIOC8A, MTIOC8B, MTIOC8C, MTIOC8D	I/O	The TGRA8 to TGRD8 input capture input/output compare output/PWM output pins
	MTCLKA, MTCLKB, MTCLKC, MTCLKD	Input	Input pins for external clock signals or for phase counting mode clock signals
Port output enable 3	POE0#, POE4#, POE8#, POE10#, POE11#	Input	Input pins for request signals to place the MTU or GPT in the high impedance state

Table 1.4 Pin Functions (3/8)

Classifications	Pin Name	I/O	Description
General-purpose PWM timer	GTIOC0A-A/GTIOC0A-B/ GTIOC0A-C/GTIOC0A-D/ GTIOC0A-E, GTIOC0B-A/GTIOC0B-B/ GTIOC0B-C/GTIOC0B-D/ GTIOC0B-E	I/O	GPT0.GTGRA and GPT0.GTGRB input capture input/output compare output/PWM output pins
	GTIOC1A-A/GTIOC1A-B/ GTIOC1A-C/GTIOC1A-D/ GTIOC1A-E, GTIOC1B-A/GTIOC1B-B/ GTIOC1B-C/GTIOC1B-D/ GTIOC1B-E	I/O	GPT1.GTGRA and GPT1.GTGRB input capture input/output compare output/PWM output pins
	GTIOC2A-A/GTIOC2A-B/ GTIOC2A-C/GTIOC2A-D/ GTIOC2A-E, GTIOC2B-A/GTIOC2B-B/ GTIOC2B-C/GTIOC2B-D/ GTIOC2B-E	I/O	GPT2.GTGRA and GPT2.GTGRB input capture input/output compare output/PWM output pins
	GTIOC3A-D/GTIOC3A-E, GTIOC3B-D/GTIOC3B-E	I/O	GPT3.GTGRA and GPT3.GTGRB input capture input/output compare output/PWM output pins
	GTETRГ-B/GTETRГ-C/ GTETRГ-D	Input	External trigger input pin for GPT0 to GPT3
	16-bit timer pulse unit	TIOCA0, TIOCB0, TIOCC0, TIOCD0	I/O
TIOCA1, TIOCB1		I/O	The TGRA1 and TGRB1 input capture input/output compare output/PWM output pins
TIOCA2, TIOCB2		I/O	The TGRA2 and TGRB2 input capture input/output compare output/PWM output pins
TIOCA3, TIOCB3, TIOCC3, TIOCD3		I/O	The TGRA3 to TGRD3 input capture input/output compare output/PWM output pins
TIOCA4, TIOCB4		I/O	The TGRA4 and TGRB4 input capture input/output compare output/PWM output pins
TIOCA5, TIOCB5		I/O	The TGRA5 and TGRB5 input capture input/output compare output/PWM output pins
TCLKA, TCLKB, TCLKC, TCLKD		Input	Input pins for external clock signals or for phase counting mode clock signals
Programmable pulse generator	PO0 to PO31	Output	Output pins for the pulse signals
8-bit timer	TMO0 to TMO3	Output	Compare match output pins
	TMCI0 to TMCI3	Input	Input pins for external clocks to be input to the counter
	TMRI0 to TMRI3	Input	Input pins for the counter reset
Compare match timer W	TIC0 to TIC3	Input	Input pins for CMTW
	TOC0 to TOC3	Output	Output pins for CMTW

Table 1.4 Pin Functions (4/8)

Classifications	Pin Name	I/O	Description	
Serial communications interface (SClg)	• Asynchronous mode/clock synchronous mode			
	SCK0 to SCK7	I/O	Input/output pins for the clock	
	RXD0 to RXD7	Input	Input pins for received data	
	TXD0 to TXD7	Output	Output pins for transmitted data	
	CTS0# to CTS7#	Input	Input pins for controlling the start of transmission and reception	
	RTS0# to RTS7#	Output	Output pins for controlling the start of transmission and reception	
	• Simple I ² C mode			
	SSCL0 to SSCL7	I/O	Input/output pins for the I ² C clock	
	SSDA0 to SSDA7	I/O	Input/output pins for the I ² C data	
	• Simple SPI mode			
	SCK0 to SCK7	I/O	Input/output pins for the clock	
	SMISO0 to SMISO7	I/O	Input/output pins for slave transmission of data	
	SMOSI0 to SMOSI7	I/O	Input/output pins for master transmission of data	
	SS0# to SS7#	Input	Chip-select input pins	
	Serial communications interface (SClh)	• Asynchronous mode/clock synchronous mode		
SCK12		I/O	Input/output pin for the clock	
RXD12		Input	Input pin for received data	
TXD12		Output	Output pin for transmitted data	
CTS12#		Input	Input pin for controlling the start of transmission and reception	
RTS12#		Output	Output pin for controlling the start of transmission and reception	
• Simple I ² C mode				
SSCL12		I/O	Input/output pin for the I ² C clock	
SSDA12		I/O	Input/output pin for the I ² C data	
• Simple SPI mode				
SCK12		I/O	Input/output pin for the clock	
SMISO12		I/O	Input/output pin for slave transmission of data	
SMOSI12		I/O	Input/output pin for master transmission of data	
SS12#		Input	Chip-select input pin	
• Extended serial mode				
RDX12		Input	Input pin for received data	
TXDX12		Output	Output pin for transmitted data	
SIOX12		I/O	Input/output pin for received or transmitted data	
Serial communications interface with FIFO (SCIFA)		SCK8 to SCK11	I/O	Input/output pins for the clock
		RXD8 to RXD11	Input	Input pins for received data
		TXD8 to TXD11	Output	Output pins for transmitted data
	CTS8# to CTS11#	Input	Input pins for controlling the start of transmission and reception	
	RTS8# to RTS11#	Output	Output pins for controlling the start of transmission and reception	
I ² C bus interface	SCL0[FM+], SCL2	I/O	Input/output pins for clocks. Bus can be directly driven by the N-channel open drain	
	SDA0[FM+], SDA2	I/O	Input/output pins for data. Bus can be directly driven by the N-channel open drain	

Table 1.4 Pin Functions (5/8)

Classifications	Pin Name	I/O	Description
Ethernet controller	REF50CK0, REF50CK1	Input	50-MHz reference clocks. These pins input reference signals for transmission/reception timings in RMII mode.
	RMII0_CRS_DV, RMII1_CRS_DV	Input	Indicate that there are carrier detection signals and valid receive data on RMII_RXD1 and RMII_RXD0 in RMII mode.
	RMII0_TXD0, RMII0_TXD1, RMII1_TXD0, RMII1_TXD1	Output	2-bit transmit data in RMII mode
	RMII0_RXD0, RMII0_RXD1, RMII1_RXD0, RMII1_RXD1	Input	2-bit receive data in RMII mode
	RMII0_TXD_EN, RMII1_TXD_EN	Output	Output pins for data transmit enable signals in RMII mode
	RMII0_RX_ER, RMII1_RX_ER	Input	Indicate an error has occurred during reception of data in RMII mode.
	ET0_CRS, ET1_CRS	Input	Carrier detection/data reception enable pins
	ET0_RX_DV, ET1_RX_DV	Input	Indicate that there are valid receive data on ET_ERXD3 to ET_ERXD0.
	ET0_EXOUT, ET1_EXOUT	Output	General-purpose external output pins
	ET0_LINKSTA, ET1_LINKSTA	Input	Input link status from the PHY-LSI.
	ET0_ETXD0 to ET0_ETXD3, ET1_ETXD0 to ET1_ETXD3	Output	4 bits of MII transmit data
	ET0_ERXD0 to ET0_ERXD3, ET1_ERXD0 to ET1_ERXD3	Input	4 bits of MII receive data
	ET0_TX_EN, ET1_TX_EN	Output	Transmit enable pins. Function as signals indicating that transmit data is ready on ET_ETXD3 to ET_ETXD0.
	ET0_TX_ER, ET1_TX_ER	Output	Transmit error pins. Function as signals notifying the PHY-LSI of an error during transmission.
	ET0_RX_ER, ET1_RX_ER	Input	Receive error pins. Function as signals to recognize an error during reception.
	ET0_TX_CLK, ET1_TX_CLK	Input	Transmit clock pins. These pins input reference signals for output timings from ET_TX_EN, ET_ETXD3 to ET_ETXD0, and ET_TX_ER.
	ET0_RX_CLK, ET1_RX_CLK	Input	Receive clock pins. These pins input reference signals for input timings to ET_RX_DV, ET_ERXD3 to ET_ERXD0, and ET_RX_ER.
	ET0_COL, ET1_COL	Input	Input collision detection signals.
	ET0_WOL, ET1_WOL	Output	Receive Magic packets.
	ET0_MDC, ET1_MDC	Output	Output reference clock signals for information transfer via ET_MDIO.
ET0_MDIO, ET1_MDIO	I/O	Input or output bidirectional signals for exchange of management information between this MCU and the PHY-LSI.	

Table 1.4 Pin Functions (6/8)

Classifications	Pin Name	I/O	Description
USB 2.0 host/function module	VCC_USB, VCC_USBA	Input	Power supply pins
	VSS_USB, VSS1_USBA, VSS2_USBA	Input	Ground pins
	AVCC_USBA	Input	USBA analog power supply pin
	AVSS_USBA	Input	USBA analog ground pin. Short this pin with the PVSS_USBA pin.
	PVSS_USBA	Input	USBA PLL circuit ground pin. Short this pin with the AVSS_USBA pin.
	USBA_RREF	I/O	USBA reference current supply pin. Connect 2.2 kΩ (±1%) to the AVSS_USBA pin.
	USB0_DP, USBA_DP	I/O	Input or output USB transceiver D+ data.
	USB0_DM, USBA_DM	I/O	Input or output USB transceiver D- data.
	USB0_EXICEN, USBA_EXICEN	Output	Connect to the OTG power IC.
	USB0_ID, USBA_ID	Input	Connect to the OTG power IC.
	USB0_VBUSEN, USBA_VBUSEN	Output	USB VBUS power enable pins
	USB0_OVRCURA/ USB0_OVRCURB, USBA_OVRCURA/ USBA_OVRCURB	Input	USB overcurrent pins
USB0_VBUS, USBA_VBUS	Input	USB cable connection/disconnection detection input pins	
CAN module	CRX0, CRX1-DS, CRX2	Input	Input pins
	CTX0 to CTX2	Output	Output pins
Serial peripheral interface	RSPCKA-A/RSPCKA-B/ RSPCKB-A/RSPCKB-B	I/O	Clock input/output pin
	MOSIA-A/MOSIA-B/ MOSIB-A/MOSIB-B	I/O	Inputs or outputs data output from the master
	MISOA-A/MISOA-B/ MISOB-A/MISOB-B	I/O	Inputs or outputs data output from the slave
	SSLA0-A/SSLA0-B/ SSLB0-A/SSLB0-B	I/O	Input or output pin for slave selection
	SSLA1-A/SSLA1-B/ SSLB1-A/SSLB1-B to SSLA3-A/SSLA3-B/ SSLB3-A/SSLB3-B	Output	Output pin for slave selection
Quad serial peripheral interface	QSPCLK-A/-B	Output	QSPI clock output pin
	QSSL-A/-B	Output	QSPI slave output pin
	QMO-A/-B, QIO0-A/-B	I/O	Master transmit data/data 0
	QMI-A/-B, QIO1-A/-B	I/O	Master input data/data 1
	QIO2-A/-B, QIO3-A/-B	I/O	Data 2, data 3
Serial sound interface	SSISCK0, SSISCK1	I/O	SSI serial bit clock pins
	SSIWS0, SSIWS1	I/O	Word select pins
	SSITXD0	Output	Serial data output pins
	SSIRXD0	Input	Serial data input pins
	SSIDATA1	I/O	Serial data input/output pins
	AUDIO_MCLK	Input	Master clock pin for audio

Table 1.4 Pin Functions (7/8)

Classifications	Pin Name	I/O	Description
MMC host interface	MMC_CLK-A/ MMC_CLK-B	Output	MMC clock pin
	MMC_CMD-A/ MMC_CMD-B	I/O	Command/response pin
	MMC_D7-A/MMC_D7-B to MMC_D0-A/MMC_D0-B	I/O	Transmit data/receive data
	MMC_CD-A/MMC_CD-B	Input	Card detection pin
	MMC_RES#-A/MMC_RES#-B	Output	MMC reset output pin
SD host interface	SDHI_CLK-A/SDHI_CLK-B	Output	SD clock output pin
	SDHI_CMD-A/SDHI_CMD-B	I/O	SD command output, response input signal pin
	SDHI_D3-A/SDHI_D3-B to SDHI_D0-A/SDHI_D0-B	I/O	SD data bus pins
	SDHI_CD-A/SDHI_CD-B	Input	SD card detection pin
	SDHI_WP-A/SDHI_WP-B	Input	SD write-protect signal
Parallel data capture unit	PIXCLK	Input	Image transfer clock pin
	VSYNC	Input	Vertical synchronization signal pin
	HSYNC	Input	Horizontal synchronization signal pin
	PIXD0 to PIXD7	Input	8-bit image data pins
	PCKO	Output	Output pin for dot clock
Realtime clock	RTCOUT	Output	Output pin for 1-Hz/64-Hz clock
	RTCIC0 to RTCIC2	Input	Time capture event input pins
12-bit A/D converter	AN000 to AN007, AN100 to AN120	Input	Input pins for the analog signals to be processed by the A/D converter
	ADTRG0#, ADTRG1#	Input	Input pins for the external trigger signals that start the A/D conversion
	ANEX0	Output	Extended analog output pin
	ANEX1	Input	Extended analog input pin
12-bit D/A converter	DA0, DA1	Output	Output pins for the analog signals to be processed by the D/A converter
Analog power supply	AVCC0	Input	Analog voltage supply pin for the 12-bit A/D converter (unit 0). Connect this pin to a branch from the VCC power supply.
	AVSS0	Input	Analog ground pin for the 12-bit A/D converter (unit 0). Connect this pin to a branch from the VSS ground power supply.
	VREFH0	Input	Analog reference voltage supply pin for the 12-bit A/D converter (unit 0). Connect this pin to VCC if the 12-bit A/D converter is not to be used.
	VREFL0	Input	Analog reference ground pin for the 12-bit A/D converter (unit 0). Connect this pin to VSS if the 12-bit A/D converter is not to be used.
	AVCC1	Input	Analog voltage supply and reference voltage supply pin for the 12-bit A/D converter (unit 1) and D/A converter. This pin also supplies the analog voltage to the temperature sensor. Connect this pin to a branch from the VCC power supply.
	AVSS1	Input	Analog voltage supply and reference voltage supply pin for the 12-bit A/D converter (unit 1) and D/A converter. This pin also supplies the analog ground voltage to the temperature sensor. Connect this pin to a branch from the VSS ground power supply.

Table 1.4 Pin Functions (8/8)

Classifications	Pin Name	I/O	Description
I/O ports	P00 to P03, P05, P07	I/O	6-bit input/output pins
	P10 to P17	I/O	8-bit input/output pins
	P20 to P27	I/O	8-bit input/output pins
	P30 to P37	I/O	8-bit input/output pins (P35: input pin)
	P40 to P47	I/O	8-bit input/output pins
	P50 to P56	I/O	7-bit input/output pins (176-pin devices have only P50 to P53)
	P60 to P67	I/O	8-bit input/output pins
	P70 to P77	I/O	8-bit input/output pins
	P80 to P83, P86, P87	I/O	6-bit input/output pins
	P90 to P97	I/O	8-bit input/output pins
	PA0 to PA7	I/O	8-bit input/output pins
	PB0 to PB7	I/O	8-bit input/output pins
	PC0 to PC7	I/O	8-bit input/output pins
	PD0 to PD7	I/O	8-bit input/output pins
	PE0 to PE7	I/O	8-bit input/output pins
	PF0 to PF5	I/O	6-bit input/output pins
	PG0 to PG7	I/O	8-bit input/output pins
	PJ3, PJ5	I/O	2-bit input/output pins

Note: Note the following regarding pin names. For details, see section 1.5, Pin Assignments.

- We recommend using pins that have a letter ("-A", "-B", etc.) to indicate group membership appended to their names as groups. For the RSPI, QSPI, SDHI, and MMC interfaces, the AC portion of the electrical characteristics is measured for each group.
- Pins that have "-DS" appended to their names can be used as triggers for release from deep software standby.
- RIIC pin functions that have [FM+] appended to their names support fast-mode plus.

1.5 Pin Assignments

Figure 1.3 to Figure 1.9 show the pin assignments. Table 1.5 to Table 1.10 show the lists of pins and pin functions.

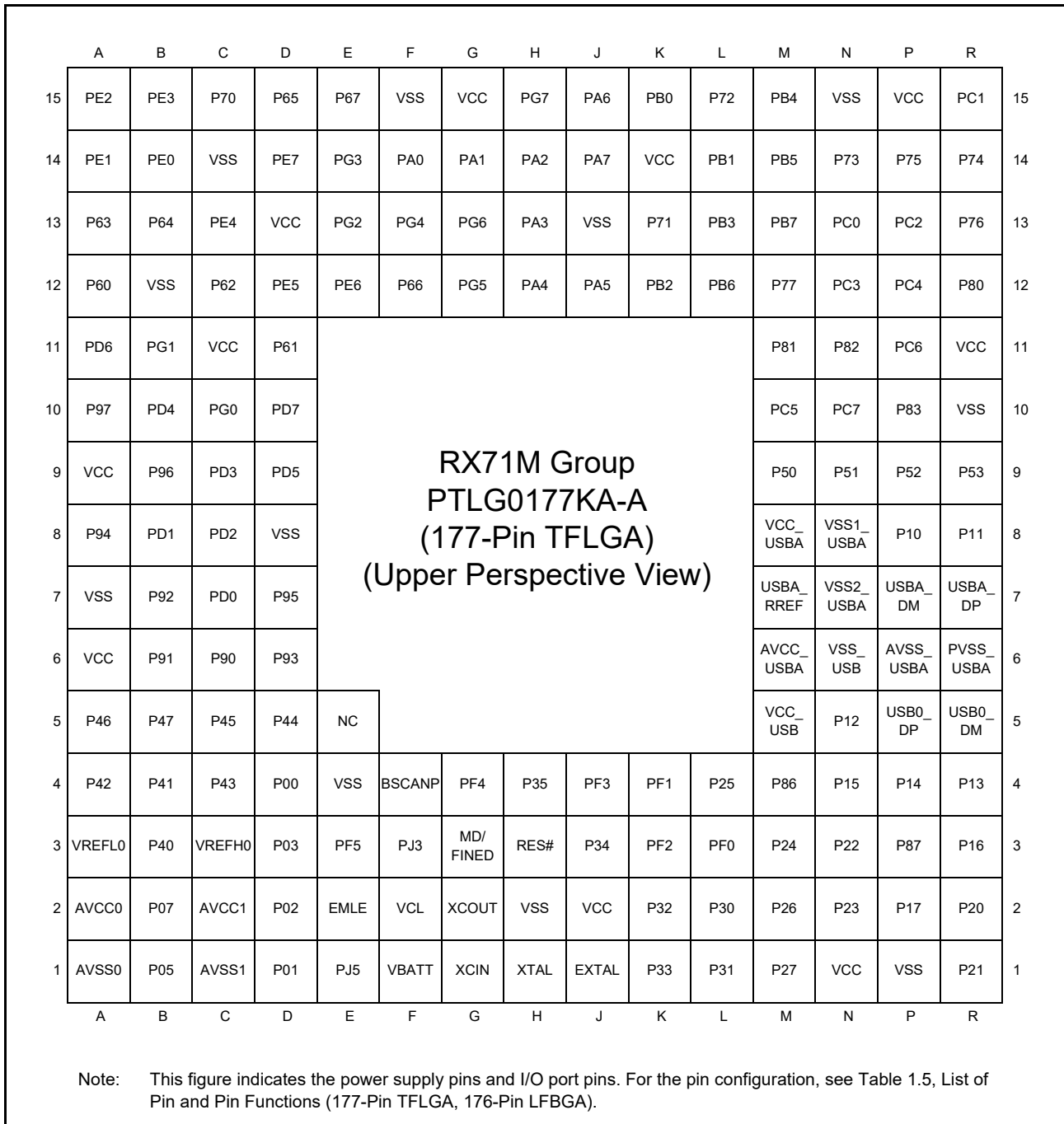

Figure 1.3 Pin Assignment (177-Pin TFLGA)

	A	B	C	D	E	F	G	H	J	K	L	M	N	P	R		
15	PE2	PE3	P70	P65	P67	VSS	VCC	PG7	PA6	PB0	P72	PB4	VSS	VCC	PC1	15	
14	PE1	PE0	VSS	PE7	PG3	PA0	PA1	PA2	PA7	VCC	PB1	PB5	P73	P75	P74	14	
13	P63	P64	PE4	VCC	PG2	PG4	PG6	PA3	VSS	P71	PB3	PB7	PC0	PC2	P76	13	
12	P60	VSS	P62	PE5	PE6	P66	PG5	PA4	PA5	PB2	PB6	P77	PC3	PC4	P80	12	
11	PD6	PG1	VCC	P61	RX71M Group PLBG0176GA-A (176-Pin LFBGA) (Upper Perspective View)								P81	P82	PC6	VCC	11
10	P97	PD4	PG0	PD7									PC5	PC7	P83	VSS	10
9	VCC	P96	PD3	PD5									P50	P51	P52	P53	9
8	P94	PD1	PD2	VSS									VCC_USBA	VSS1_USBA	P10	P11	8
7	VSS	P92	PD0	P95									USBA_RREF	VSS2_USBA	USBA_DM	USBA_DP	7
6	VCC	P91	P90	P93									AVCC_USBA	VSS_USB	AVSS_USBA	PVSS_USBA	6
5	P46	P47	P45	P44	VCC_USB	P12	USB0_DP	USB0_DM	5								
4	P42	P41	P43	P00	VSS	BSCANP	PF4	P35	PF3	PF1	P25	P86	P15	P14	P13	4	
3	VREFL0	P40	VREFH0	P03	PF5	PJ3	MD/ FINED	RES#	P34	PF2	PF0	P24	P22	P87	P16	3	
2	AVCC0	P07	AVCC1	P02	EMLE	VCL	XCOUT	VSS	VCC	P32	P30	P26	P23	P17	P20	2	
1	AVSS0	P05	AVSS1	P01	PJ5	VBATT	XCIN	XTAL	EXTAL	P33	P31	P27	VCC	VSS	P21	1	
	A	B	C	D	E	F	G	H	J	K	L	M	N	P	R		

Note: This figure indicates the power supply pins and I/O port pins. For the pin configuration, see Table 1.5, List of Pin and Pin Functions (177-Pin TFLGA, 176-Pin LFBGA).

Figure 1.4 Pin Assignment (176-Pin LFBGA)



Figure 1.5 Pin Assignment (176-Pin LQFP)

	A	B	C	D	E	F	G	H	J	K	L	M	N	
13	PE3	PE4	VSS	PE6	P67	PA2	PA4	PA7	PB1	PB5	VSS	VCC	P74	13
12	PE1	PE2	P70	PE5	P65	PA1	VCC	PB0	PB2	PB6	P73	PC1	P75	12
11	P62	P61	PE0	VCC	P66	VSS	PA6	P71	PB4	PB7	PC2	PC0	PC3	11
10	VSS	VCC	P63	PE7	PA0	PA3	PA5	P72	PB3	P76	PC4	P77	P82	10
9	PD6	PD4	PD7	P64	RX71M Group PTLG0145KA-A (145-Pin TFLGA) (Upper Perspective View)					P80	PC5	P81	PC7	9
8	PD2	PD0	PD3	P60						VCC	P83	PC6	VSS	8
7	P92	P91	PD1	PD5						P51	P52	P50	P55	7
6	P90	P47	VSS	P93						P53	P56	VSS_USB	USB0_DP	6
5	P45	P43	P46	VCC	P44	P54	P13	VCC_USB	USB0_DM	5				
4	P42	VREFL0	P41	P01	EMLE	VBATT	BSCANP	P35	P30	P15	P24	P12	P14	4
3	P40	P05	VREFH0	P03	PJ5	PJ3	MD/ FINED	VSS	P32	P31	P16	P86	P87	3
2	P07	AVCC0	P02	PF5	VCL	XCOUT	RES#	VCC	P33	P26	P23	P17	P20	2
1	AVSS0	AVCC1	AVSS1	P00	VSS	XCIN	XTAL	EXTAL	P34	P27	P25	P22	P21	1
	A	B	C	D	E	F	G	H	J	K	L	M	N	

Note: This figure indicates the power supply pins and I/O port pins. For the pin configuration, see Table 1.7, List of Pin and Pin Functions (145-Pin TFLGA).

Figure 1.6 Pin Assignment (145-Pin TFLGA)



Figure 1.7 Pin Assignment (144-Pin LQFP)

RX71M Group
PTLG0100JA-A (100-Pin TFLGA)
(Upper Perspective View)

	A	B	C	D	E	F	G	H	J	K	
10	PE2	PE3	PE4	PA0	PA3	VSS	VCC	PB7	PC1	PC2	10
9	PE1	PD7	PE5	PA1	PA5	PA7	PB1	PB6	PC0	PC3	9
8	PE0	PD6	PD5	PE7	PA4	PB0	PB4	PC6	PC4	PC5	8
7	PD4	PD3	PD2	PE6	PA6	PB2	PB5	PC7	P50	P51	7
6	PD0	PD1	P47	P46	PA2	PB3	P52	P54	VCC_ USB	USB0_ DP	6
5	P43	P44	P42	P45	P41	P12	P53	P55	VSS_ USB	USB0_ DM	5
4	VREFL0	P40	VREFH0	VBATT	P34	P32	P27	P15	P13	P14	4
3	P07	AVCC0	PJ3	MD/ FINED	RES#	P35	P30	P16	P17	P20	3
2	AVCC1	AVSS0	AVSS1	XCOUT	VSS	VCC	P31	P25	P21	P22	2
1	P05	EMLE	VCL	XCIN	XTAL	EXTAL	P33	P26	P24	P23	1
	A	B	C	D	E	F	G	H	J	K	

Note: This figure indicates the power supply pins and I/O port pins. For the pin configuration, see Table 1.9, List of Pin and Pin Functions (100-Pin TFLGA).

Figure 1.8 Pin Assignment (100-Pin TFLGA)



Figure 1.9 Pin Assignment (100-Pin LQFP)

Table 1.5 List of Pin and Pin Functions (177-Pin TFLGA, 176-Pin LFBGA) (1/7)

Pin Number	Power Supply Clock System Control	I/O Port	Bus EXDMAC SDRAMC	Timer (MTU, GPT, TPU, TMR, PPG, RTC, CMTW, POE, CAC)	Communication (ETHERC, SC1g, SC1h, RSPI, RIIC, CAN, USB, SSI)	Memory Interface Camera Interface (QSPI, SDHI, MMCIF, PDC)	Interrupt	S12ADC, R12DA
A1	AVSS0							
A2	AVCC0							
A3	VREFL0							
A4		P42					IRQ10-DS	AN002
A5		P46					IRQ14-DS	AN006
A6	VCC							
A7	VSS							
A8		P94	A20/D20		ET1_ERXD0/ RMI11_RXD0			
A9	VCC							
A10		P97	A23/D23		ET1_ERXD3			
A11		PD6	D6[A6/D6]	MTIC5V/MTIOC8A/ POE4#		MMC_D0-B/ SDHI_D0-B/ QIO0-B/ QMO-B	IRQ6	AN106
A12		P60	CS0#		ET1_TX_EN/ RMI11_TXD_EN			
A13		P63	CS3#/CAS#					
A14		PE1	D9[A9/D9]	MTIOC4C/MTIOC3B/ GTIOC1B-A/PO18	TXD12/SMOSI12/ SSDA12/TXD12/ SIOX12/SSLB2-B	MMC_D5-B		ANEX1
A15		PE2	D10[A10/D10]	MTIOC4A/ GTIOC0B-A/PO23/ TIC3	RXD12/SMISO12/ SSCL12/RXD12/ SSLB3-B	MMC_D6-B	IRQ7-DS	AN100
B1		P05					IRQ13	DA1
B2		P07					IRQ15	ADTRG0#
B3		P40					IRQ8-DS	AN000
B4		P41					IRQ9-DS	AN001
B5		P47					IRQ15-DS	AN007
B6		P91	A17/D17		ET1_COL/SCK7			AN115
B7		P92	A18/D18	POE4#	ET1_CRS/ RMI11_CRS_DV/ RXD7/SMISO7/SSCL7			AN116
B8		PD1	D1[A1/D1]	MTIOC4B/ GTIOC1A-E/POE0#	CTX0		IRQ1	AN109
B9		P96	A22/D22		ET1_ERXD2			
B10		PD4	D4[A4/D4]	MTIOC8B/POE11#		MMC_CMD-B/ SDHI_CMD-B/ QSSL-B	IRQ4	AN112
B11		PG1	D25		ET1_RX_ER/ RMI11_RX_ER			
B12	VSS							
B13		P64	CS4#/WE#					
B14		PE0	D8[A8/D8]	MTIOC3D/ GTIOC2B-A	SCK12/SSLB1-B	MMC_D4-B		ANEX0
B15		PE3	D11[A11/D11]	MTIOC4B/ GTIOC2A-A/PO26/ POE8#/TOC3	CTS12#/RTS12#/ SS12#/ ET0_ERXD3	MMC_D7-B		AN101
C1	AVSS1							
C2	AVCC1							
C3	VREFH0							

Table 1.5 List of Pin and Pin Functions (177-Pin TFLGA, 176-Pin LFBGA) (2/7)

Pin Number	Power Supply Clock System Control	I/O Port	Bus EXDMAC SDRAMC	Timer	Communication	Memory Interface Camera Interface	Interrupt	S12ADC, R12DA
177-Pin TFLGA 176-Pin LFBGA				(MTU, GPT, TPU, TMR, PPG, RTC, CMTW, POE, CAC)	(ETHERC, SCIG, SCIh, RSPI, RIIC, CAN, USB, SSI)	(QSPI, SDHI, MMCIF, PDC)		
C4		P43					IRQ11-DS	AN003
C5		P45					IRQ13-DS	AN005
C6		P90	A16/D16		ET1_RX_DV/ TXD7/SMOSI7/SSDA7			AN114
C7		PD0	D0[A0/D0]	GTIOC1B-E/POE4#			IRQ0	AN108
C8		PD2	D2[A2/D2]	MTIOC4D/ GTIOC0B-E/TIC2	CRX0	MMC_D2-B/ SDHI_D2-B/ QIO2_B	IRQ2	AN110
C9		PD3	D3[A3/D3]	MTIOC8D/ GTIOC0A-E/POE8#/ TOC2		MMC_D3-B/ SDHI_D3-B/ QIO3-B	IRQ3	AN111
C10		PG0	D24		ET1_RX_CLK/ REF50CK1			
C11	VCC							
C12		P62	CS2#/RAS#					
C13		PE4	D12[A12/D12]	MTIOC4D/MTIOC1A/ GTIOC1A-A/PO28	ET0_ERXD2/SSLB0-B			AN102
C14	VSS							
C15		P70	SDCLK					
D1		P01		TMC10	RXD6/SMISO6/ SSCL6		IRQ9	AN119
D2		P02		TMC11	SCK6		IRQ10	AN120
D3		P03					IRQ11	DA0
D4		P00		TMR10	TXD6/SMOSI6/ SSDA6		IRQ8	AN118
D5		P44					IRQ12-DS	AN004
D6		P93	A19/D19	POE0#	ET1_LINKSTA/CTS7#/ RTS7#/SS7#			AN117
D7		P95	A21/D21		ET1_ERXD1/ RMII1_RXD1			
D8	VSS							
D9		PD5	D5[A5/D5]	MTIC5W/MTIOC8C/ POE10#		MMC_CLK-B/ SDHI_CLK-B/ QSPCLK-B	IRQ5	AN113
D10		PD7	D7[A7/D7]	MTIC5U/POE0#		MMC_D1-B/ SDHI_D1-B/ QIO1-B/QMI-B	IRQ7	AN107
D11		P61	CS1#/SDCS#					
D12		PE5	D13[A13/D13]	MTIOC4C/MTIOC2B/ GTIOC0A-A	ET0_RX_CLK/ REF50CK0/ RSPCKB-B		IRQ5	AN103
D13	VCC							
D14		PE7	D15[A15/D15]	MTIOC6A/ GTIOC3A-E/TOC1	MISOB-B	MMC_RES#-B/ SDHI_WP-B	IRQ7	AN105
D15		P65	CS5#/CKE					
E1		PJ5		POE8#	CTS2#/RTS2#/SS2#			
E2	EMLE							
E3		PF5					IRQ4	
E4	VSS							
E5*1								
E12		PE6	D14[A14/D14]	MTIOC6C/ GTIOC3B-E/TIC1	MOSIB-B	MMC_CD-B/ SDHI_CD-B	IRQ6	AN104

Table 1.5 List of Pin and Pin Functions (177-Pin TFLGA, 176-Pin LFBGA) (3/7)

Pin Number	Power Supply Clock System Control	I/O Port	Bus EXDMAC SDRAMC	Timer (MTU, GPT, TPU, TMR, PPG, RTC, CMTW, POE, CAC)	Communication (ETHERC, SCiG, SCIh, RSPI, RIIC, CAN, USB, SSI)	Memory Interface Camera Interface (QSPI, SDHI, MMCIF, PDC)	Interrupt	S12ADC, R12DA
E13	TRDATA0	PG2	D26		ET1_TX_CLK			
E14	TRDATA1	PG3	D27		ET1_ETXD0/ RMII1_TXD0			
E15		P67	CS7#/DQM1	MTIOC7C/ GTIOC1B-C	CRX2		IRQ15	
F1	VBATT							
F2	VCL							
F3		PJ3	EDACK1	MTIOC3C	ET0_EXOUT/ CTS6#/RTS6#/ CTS0#/RTS0#/ SS6#/SS0#			
F4	BSCANP							
F12		P66	CS6#/DQM0	MTIOC7D/ GTIOC2B-C	CTX2			
F13	TRSYNC	PG4	D28		ET1_ETXD1/ RMII1_TXD1			
F14		PA0	A0/BC0#/ DQM2	MTIOC4A/MTIOC6D/ GTIOC0B-C/TIOCA0/ CACREF/PO16	SSLA1-B/ ET0_TX_EN/ RMII0_TXD_EN			
F15	VSS							
G1	XCIN							
G2	XCOUT							
G3	MD/FINED							
G4	TRST#	PF4						
G12	TRCLK	PG5	D29		ET1_ETXD2			
G13	TRDATA2	PG6	D30		ET1_ETXD3			
G14		PA1	A1/DQM3	MTIOC0B/MTCLKC/ MTIOC7B/ GTIOC2A-C/TIOCB0/ PO17	SCK5/SSLA2-B/ ET0_WOL		IRQ11	
G15	VCC							
H1	XTAL	P37						
H2	VSS							
H3	RES#							
H4	UPSEL	P35					NMI	
H12		PA4	A4	MTIC5U/MTCLKA/ TIOCA1/TMRI0/PO20	TXD5/SMOSI5/ SSDA5/SSLA0-B/ ET0_MDC		IRQ5-DS	
H13		PA3	A3	MTIOC0D/MTCLKD/ TIOCD0/TCLKB/PO19	RXD5/SMISO5/ SSCL5/ ET0_MDIO		IRQ6-DS	
H14		PA2	A2	MTIOC7A/ GTIOC1A-C/PO18	RXD5/SMISO5/ SSCL5/SSLA3-B			
H15	TRDATA3	PG7	D31		ET1_TX_ER			
J1	EXTAL	P36						
J2	VCC							
J3		P34		MTIOC0A/TMCI3/ PO12/POE10#	SCK6/SCK0/ ET0_LINKSTA		IRQ4	
J4	TMS	PF3						
J12		PA5	A5	MTIOC6B/ GTIOC0A-C/TIOCB1/ PO21	RSPCKA-B/ ET0_LINKSTA			
J13	VSS							

Table 1.5 List of Pin and Pin Functions (177-Pin TFLGA, 176-Pin LFBGA) (4/7)

Pin Number	Power Supply Clock System Control	I/O Port	Bus EXDMAC SDRAMC	Timer (MTU, GPT, TPU, TMR, PPG, RTC, CMTW, POE, CAC)	Communication (ETHERC, SCIG, SCIH, RSPI, RIIC, CAN, USB, SSI)	Memory Interface Camera Interface (QSPI, SDHI, MMCIF, PDC)	Interrupt	S12ADC, R12DA
J14		PA7	A7	TIOCB2/PO23	MISOA-B/ ET0_WOL			
J15		PA6	A6	MTIC5V/MTCLKB/ GTETR-G-C/TIOCA2/ TMC13/PO22/POE10#	CTS5#/RTS5#/SS5#/ MOSIA-B/ ET0_EXOUT			
K1		P33	EDREQ1	MTIOC0D/TIOC0D/ TMR13/PO11/POE4#/ POE11#	RXD6/RXD0/ SMISO6/ SMISO0/SSCL6/ SSCL0/CRX0	PCKO	IRQ3-DS	
K2		P32		MTIOC0C/TIOCC0/ TMO3/PO10/ RTCOUT/RTCIC2/ POE0#/POE10#	TXD6/TXD0/ SMOSI6/SMOSI0/ SSDA6/SSDA0/ CTX0/ USB0_VBUSEN	VSYNC	IRQ2-DS	
K3	TDI	PF2			RXD1/SMISO1/ SSCL1			
K4	TCK	PF1			SCK1			
K12		PB2	A10	TIOCC3/TCLKC/ PO26	CTS4#/RTS4#/CTS6#/ RTS6#/SS4#/SS6#/ ET0_RX_CLK/ REF50CK0			
K13		P71	A18/CS1#		ET0_MDIO			
K14	VCC							
K15		PB0	A8	MTIC5W/TIOCA3/ PO24	RXD4/RXD6/SMISO4/ SMISO6/SSCL4/ SSCL6/ET0_ERXD1/ RMII0_RXD1		IRQ12	
L1		P31		MTIOC4D/TMC12/ PO9/RTCIC1	CTS1#/RTS1#/ SS1#/ET1_MDC/ SSLB0-A		IRQ1-DS	
L2		P30		MTIOC4B/TMR13/ PO8/RTCIC0/POE8#	RXD1/SMISO1/ SSCL1/ET1_MDIO/ MISOB-A		IRQ0-DS	
L3	TDO	PF0			TXD1/SMOSI1/ SSDA1			
L4		P25	CS5#/ EDACK1	MTIOC4C/MTCLKB/ TIOCA4/PO5	RXD3/SMISO3/ SSCL3/ SSIDATA1	HSYNC		ADTRG0#
L12		PB6	A14	MTIOC3D/TIOCA5/ PO30	RXD9/ET0_ETXD1/ RMII0_TXD1			
L13		PB3	A11	MTIOC0A/MTIOC4A/ TIOC0D3/TCLKD/ TMO0/PO27/POE11#	SCK4/SCK6/ ET0_RX_ER/ RMII0_RX_ER			
L14		PB1	A9	MTIOC0C/MTIOC4C/ TIOCB3/TMC10/PO25	TXD4/TXD6/SMOSI4/ SMOSI6/SSDA4/ SSDA6/ET0_ERXD0/ RMII0_RXD0		IRQ4-DS	
L15		P72	A19/CS2#		ET0_MDC			
M1		P27	CS7#	MTIOC2B/TMC13/PO7	SCK1/ET1_WOL/ RSPCKB-A			
M2		P26	CS6#	MTIOC2A/TMO1/PO6	TXD1/CTS3#/ RTS3#/SMOSI1/ SS3#/SSDA1/ ET1_EXOUT/ MOSIB-A			
M3		P24	CS4#/ EDREQ1	MTIOC4A/MTCLKA/ TIOCB4/TMR11/PO4	SCK3/ USB0_VBUSEN/ SSISCK1	PIXCLK		
M4		P86		MTIOC4D/ GTIOC2B-B/TIOCA0	RXD10	PIXD1		

Table 1.5 List of Pin and Pin Functions (177-Pin TFLGA, 176-Pin LFBGA) (5/7)

Pin Number	Power Supply Clock System Control	I/O Port	Bus EXDMAC SDRAMC	Timer (MTU, GPT, TPU, TMR, PPG, RTC, CMTW, POE, CAC)	Communication (ETHERC, SCIG, SCIh, RSPI, RIIC, CAN, USB, SSI)	Memory Interface Camera Interface (QSPI, SDHI, MMCIF, PDC)	Interrupt	S12ADC, R12DA
M5	VCC_USB							
M6	AVCC_ USBA_							
M7	USBA_ RREF							
M8	VCC_ USBA							
M9		P50	WR0#/WR#		TXD2/SMOSI2/ SSDA2/SSLB1-A			
M10		PC5	A21/CS2#/ WAIT#	MTIOC3B/MTCLKD/ GTIOC1A-D/TMRI2/ PO29	SCK8/RSPCKA-A/ RTS8#/ET0_ETXD2	MMC_D5-A		
M11		P81	EDACK0	MTIOC3D/ GTIOC0B-D/PO27	RXD10/ET0_ETXD0/ RMII0_TXD0	MMC_D3-A/ SDHI_CD-A/ QIO3-A		
M12		P77	CS7#	PO23	TXD11/ET0_RX_ER/ RMII0_RX_ER	MMC_CLK-A/ SDHI_CLK-A/ QSPCLK-A		
M13		PB7	A15	MTIOC3B/TIOCB5/ PO31	TXD9/ET0_CRS/ RMII0_CRS_DV			
M14		PB5	A13	MTIOC2A/MTIOC1B/ TIOCB4/TMRI1/PO29/ POE4#	SCK9/RTS9#/ ET0_ETXD0/ RMII0_TXD0			
M15		PB4	A12	TIOCA4/PO28	CTS9#/ET0_TX_EN/ RMII0_TXD_EN			
N1	VCC							
N2		P23	EDACK0	MTIOC3D/MTCLKD/ GTIOC0A-B/TIOCD3/ PO3	TXD3/CTS0#/ RTS0#/SMOSI3/ SS0#/SSDA3/ SSISCK0	PIXD7		
N3		P22	EDREQ0	MTIOC3B/MTCLKC/ GTIOC1A-B/TIOCC3/ TMO0/PO2	SCK0/ USB0_OVRCURB/ USBA_OVRCURB/ AUDIO_MCLK	PIXD6		
N4		P15		MTIOC0B/MTCLKB/ GTETRG-B/TIOCB2/ TCLKB/TMCI2/PO13	RXD1/SCK3/ SMISO1/SSCL1/ CRX1-DS/ USBA_VBUSEN/ SSIWS1	PIXD0	IRQ5	
N5		P12	WR3#/BC3#	MTIC5U/TMCI1	RXD2/SMISO2/ SSCL2/ SCL0[FM+]		IRQ2	
N6	VSS_USB							
N7	VSS2_ USBA							
N8	VSS1_ USBA							
N9		P51	WR1#/BC1#/ WAIT#		SCK2/SSLB2-A			
N10	UB	PC7	A23/CS0#	MTIOC3A/MTCLKB/ GTIOC3A-D/TMO2/ TOC0/PO31/CACREF	TXD8/MISOA-A/ ET0_COL	MMC_D7-A	IRQ14	
N11		P82	EDREQ1	MTIOC4A/ GTIOC2A-D/PO28	TXD10/ET0_ETXD1/ RMII0_TXD1	MMC_D4-A		
N12		PC3	A19	MTIOC4D/ GTIOC1B-D/TCLKB/ PO24	TXD5/SMOSI5/ SSDA5/ ET0_TX_ER	MMC_D0-A/ SDHI_D0-A/ QIO0-A/ QMO-A		
N13		PC0	A16	MTIOC3C/TCLKC/ PO17	CTS5#/RTS5#/SS5#/ SSLA1-A/ET0_ERXD3		IRQ14	

Table 1.5 List of Pin and Pin Functions (177-Pin TFLGA, 176-Pin LFBGA) (6/7)

Pin Number	Power Supply Clock System Control	I/O Port	Bus EXDMAC SDRAMC	Timer	Communication	Memory Interface Camera Interface	Interrupt	S12ADC, R12DA
177-Pin TFLGA 176-Pin LFBGA				(MTU, GPT, TPU, TMR, PPG, RTC, CMTW, POE, CAC)	(ETHERC, SCIG, SCIH, RSPI, RIIC, CAN, USB, SSI)	(QSPI, SDHI, MMCIF, PDC)		
N14		P73	CS3#	PO16	ET0_WOL			
N15	VSS							
P1	VSS							
P2		P17		MTIOC3A/MTIOC3B/ MTIOC4B/ GTIOC0B-B/TIOC0B/ TCLKD/TMO1/PO15/ POE8#	SCK1/TXD3/ SMOSI3/SSDA3/ SDA2-DS/ SSITXD0	PIXD3	IRQ7	ADTRG1#
P3		P87		MTIOC4C/ GTIOC1B-B/TIOCA2	TXD10	PIXD2		
P4		P14		MTIOC3A/MTCLKA/ TIOC0B5/TCLKA/ TMRI2/PO15	CTS1#/RTS1#/ SS1#/CTX1/ USB0_OVRCURA		IRQ4	
P5					USB0_DP			
P6	AVSS_ USBA							
P7					USBA_DM			
P8		P10	ALE	MTIC5W/TMRI3	USBA_OVRCURA		IRQ0	
P9		P52	RD#		RXD2/SMISO2/ SSCL2/SSLB3-A			
P10		P83	EDACK1	MTIOC4C/ GTIOC0A-D	CTS10#/ET0_CRS/ RMII0_CRS_DV/ SCK10			
P11		PC6	A22/CS1#	MTIOC3C/MTCLKA/ GTIOC3B-D/TMCI2/ TIC0/PO30	RXD8/MOSIA-A/ ET0_ETXD3	MMC_D6-A	IRQ13	
P12		PC4	A20/CS3#	MTIOC3D/MTCLKC/ GTETR-D/TMCI1/ PO25/POE0#	SCK5/CTS8#/SSLA0- A/ET0_TX_CLK	MMC_D1-A/ SDHI_D1-A/ QIO1-A/QMI-A		
P13		PC2	A18	MTIOC4B/ GTIOC2B-D/TCLKA/ PO21	RXD5/SMISO5/ SSCL5/SSLA3-A/ ET0_RX_DV	MMC_CD-A/ SDHI_D3-A		
P14		P75	CS5#	PO20	SCK11/RTS11/ ET0_ERXD0/ RMII0_RXD0	MMC_RES#-A/ SDHI_D2-A		
P15	VCC							
R1		P21		MTIOC1B/MTIOC4A/ GTIOC2A-B/TIOCA3/ TMCI0/PO1	RXD0/SMISO0/ SSCL0/ USB0_EXICEN/ USBA_EXICEN/ SSIWS0	PIXD5	IRQ9	
R2		P20		MTIOC1A/TIOC0B3/ TMRI0/PO0	TXD0/SMOSI0/ SSDA0/USB0_ID/ USBA_ID/ SSIRXD0	PIXD4	IRQ8	
R3		P16		MTIOC3C/MTIOC3D/ TIOC0B1/TCLKC/ TMO2/PO14/ RTCOUT	TXD1/RXD3/ SMOSI1/SMISO3/ SSDA1/SSCL3/ SCL2-DS/ USB0_VBUS/ USB0_VBUSEN/ USB0_OVRCURB		IRQ6	ADTRG0#
R4		P13	WR2#/BC2#	MTIOC0B/TIOCA5/ TMO3/PO13	TXD2/SMOSI2/ SSDA2/ SDA0[FM+]		IRQ3	ADTRG1#
R5					USB0_DM			
R6	PVSS_ USBA							
R7					USBA_DP			

Table 1.5 List of Pin and Pin Functions (177-Pin TFLGA, 176-Pin LFBGA) (7/7)

Pin Number 177-Pin TFLGA 176-Pin LFBGA	Power Supply Clock System Control	I/O Port	Bus EXDMAC SDRAMC	Timer (MTU, GPT, TPU, TMR, PPG, RTC, CMTW, POE, CAC)	Communication (ETHERC, SC1g, SC1h, RSPI, RIIC, CAN, USB, SSI)	Memory Interface Camera Interface (QSPI, SDHI, MMCIF, PDC)	Interrupt	S12ADC, R12DA
R8		P11		MTIC5V/TMC13	SCK2/ USBA_VBUS/ USBA_VBUSEN		IRQ1	
R9		P53*2	BCLK					
R10	VSS							
R11	VCC							
R12		P80	EDREQ0	MTIOC3B/PO26	SCK10/RTS10#/ ET0_TX_EN/ RMII0_TXD_EN	MMC_D2-A/ SDHI_WP-A/ QIO2-A		
R13		P76	CS6#	PO22	RXD11/ET0_RX_CLK/ REF50CK0	MMC_CMD-A/ SDHI_CMD-A/ QSSL-A		
R14		P74	A20/CS4#	PO19	CTS11#/ET0_ERXD1/ RMII0_RXD1			
R15		PC1	A17	MTIOC3A/TCLKD/ PO18	SCK5/SSLA2-A/ ET0_ERXD2		IRQ12	

Note 1. The 176-pin LFBGA does not include the E5 pin.

Note 2. The BCLK function is multiplexed with the I/O port function for pin P53, so the port function is not available if the external bus is enabled.

Table 1.6 List of Pin and Pin Functions (176-Pin LQFP) (1/7)

Pin Number	Power Supply Clock System Control	I/O Port	Bus EXDMAC SDRAMC	Timer (MTU, GPT, TPU, TMR, PPG, RTC, CMTW, POE, CAC)	Communication (ETHERC, SC1g, SC1h, RSPI, RIIC, CAN, USB, SSI)	Memory Interface Camera Interface (QSPI, SDHI, MMCIF, PDC)	Interrupt	S12ADC, R12DA
1	AVSS0							
2		P05					IRQ13	DA1
3	AVCC1							
4		P03					IRQ11	DA0
5	AVSS1							
6		P02		TMCI1	SCK6		IRQ10	AN120
7		P01		TMCI0	RXD6/SMISO6/ SSCL6		IRQ9	AN119
8		P00		TMRI0	TXD6/SMOSI6/ SSDA6		IRQ8	AN118
9		PF5					IRQ4	
10	EMLE							
11		PJ5		POE8#	CTS2#/RTS2#/SS2#			
12	VSS							
13		PJ3	EDACK1	MTIOC3C	ET0_EXOUT/ CTS6#/RTS6#/ CTS0#/RTS0#/ SS6#/SS0#			
14	VCL							
15	VBATT							
16	NC							
17	TRST#	PF4						
18	MD/FINED							
19	XCIN							
20	XCOU							
21	RES#							
22	XTAL	P37						
23	VSS							
24	EXTAL	P36						
25	VCC							
26	UPSEL	P35					NMI	
27		P34		MTIOC0A/TMCI3/ PO12/POE10#	SCK6/SCK0/ ET0_LINKSTA		IRQ4	
28		P33	EDREQ1	MTIOC0D/TIOC0D/ TMRI3/PO11/POE4#/ POE11#	RXD6/RXD0/ SMISO6/ SMISO0/SSCL6/ SSCL0/CRX0	PCKO	IRQ3-DS	
29		P32		MTIOC0C/TIOCC0/ TMO3/PO10/ RTCOU/RTCIC2/ POE0#/POE10#	TXD6/TXD0/ SMOSI6/SMOSI0/ SSDA6/SSDA0/ CTX0/ USB_VBUSEN	VSYNC	IRQ2-DS	
30	TMS	PF3						
31	TDI	PF2			RXD1/SMISO1/ SSCL1			
32		P31		MTIOC4D/TMCI2/ PO9/RTCIC1	CTS1#/RTS1#/ SS1#/ET1_MDC/ SSLB0-A		IRQ1-DS	
33		P30		MTIOC4B/TMRI3/ PO8/RTCIC0/POE8#	RXD1/SMISO1/ SSCL1/ET1_MDIO/ MISOB-A		IRQ0-DS	
34	TCK	PF1			SCK1			
35	TDO	PF0			TXD1/SMOSI1/SSDA1			

Table 1.6 List of Pin and Pin Functions (176-Pin LFQFP) (2/7)

Pin Number	Power Supply Clock System Control	I/O Port	Bus EXDMAC SDRAMC	Timer (MTU, GPT, TPU, TMR, PPG, RTC, CMTW, POE, CAC)	Communication (ETHERC, SC1g, SC1h, RSPI, RIIC, CAN, USB, SSI)	Memory Interface Camera Interface (QSPI, SDHI, MMCIF, PDC)	Interrupt	S12ADC, R12DA
36		P27	CS7#	MTIOC2B/TMC13/PO7	SCK1/ET1_WOL/ RSPCKB-A			
37		P26	CS6#	MTIOC2A/TMO1/PO6	TXD1/CTS3#/ RTS3#/SMOSI1/ SS3#/SSDA1/ ET1_EXOUT/ MOSIB-A			
38		P25	CS5#/ EDACK1	MTIOC4C/MTCLKB/ TIOCA4/PO5	RXD3/SMISO3/ SSCL3/ SSIDATA1	HSYNC		ADTRG0#
39	VCC							
40		P24	CS4#/ EDREQ1	MTIOC4A/MTCLKA/ TIOCB4/TMRI1/PO4	SCK3/ USB0_VBUSEN/ SSISCK1	PIXCLK		
41	VSS							
42		P23	EDACK0	MTIOC3D/MTCLKD/ GTIOC0A-B/TIOCD3/ PO3	TXD3/CTS0#/ RTS0#/SMOSI3/ SS0#/SSDA3/ SSISCK0	PIXD7		
43		P22	EDREQ0	MTIOC3B/MTCLKC/ GTIOC1A-B/TIOCC3/ TMO0/PO2	SCK0/ USB0_OVRCURB/ USBA_OVRCURB/ AUDIO_MCLK	PIXD6		
44		P21		MTIOC1B/MTIOC4A/ GTIOC2A-B/TIOCA3/ TMC10/PO1	RXD0/SMISO0/ SSCL0/ USB0_EXICEN/ USBA_EXICEN/ SSIWS0	PIXD5	IRQ9	
45		P20		MTIOC1A/TIOCB3/ TMRI0/PO0	TXD0/SMOSI0/ SSDA0/USB0_ID/ USBA_ID/ SSIRXD0	PIXD4	IRQ8	
46		P17		MTIOC3A/MTIOC3B/ MTIOC4B/ GTIOC0B-B/TIOCB0/ TCLKD/TMO1/PO15/ POE8#	SCK1/TXD3/ SMOSI3/SSDA3/ SDA2-DS/ SSITXD0	PIXD3	IRQ7	ADTRG1#
47		P87		MTIOC4C/ GTIOC1B-B/TIOCA2	TXD10	PIXD2		
48		P16		MTIOC3C/MTIOC3D/ TIOCB1/TCLKC/ TMO2/PO14/ RTCOUT	TXD1/RXD3/ SMOSI1/SMISO3/ SSDA1/SSCL3/ SCL2-DS/ USB0_VBUS/ USB0_VBUSEN/ USB0_OVRCURB		IRQ6	ADTRG0#
49		P86		MTIOC4D/ GTIOC2B-B/TIOCA0	RXD10	PIXD1		
50		P15		MTIOC0B/MTCLKB/ GTETR-G/TIOCB2/ TCLKB/TMC12/PO13	RXD1/SCK3/ SMISO1/SSCL1/ CRX1-DS/ USBA_VBUSEN/ SSIWS1	PIXD0	IRQ5	
51		P14		MTIOC3A/MTCLKA/ TIOCB5/TCLKA/ TMRI2/PO15	CTS1#/RTS1#/ SS1#/CTX1/ USB0_OVRCURA		IRQ4	
52		P13	WR2#/BC2#	MTIOC0B/TIOCA5/ TMO3/PO13	TXD2/SMOSI2/ SSDA2/ SDA0[FM+]		IRQ3	ADTRG1#
53		P12	WR3#/BC3#	MTIC5U/TMC11	RXD2/SMISO2/ SSCL2/ SCL0[FM+]		IRQ2	
54	VCC_USB							
55					USB0_DM			

Table 1.6 List of Pin and Pin Functions (176-Pin LQFP) (3/7)

Pin Number	Power Supply Clock System Control	I/O Port	Bus EXDMAC SDRAMC	Timer (MTU, GPT, TPU, TMR, PPG, RTC, CMTW, POE, CAC)	Communication (ETHERC, SC1g, SC1h, RSPI, RIIC, CAN, USB, SSI)	Memory Interface Camera Interface (QSPI, SDHI, MMCIF, PDC)	Interrupt	S12ADC, R12DA
56					USB0_DP			
57	VSS_USB							
58	AVCC_USBA							
59	USBA_RREF							
60	AVSS_USBA							
61	PVSS_USBA							
62	VSS2_USBA							
63					USBA_DM			
64					USBA_DP			
65	VSS1_USBA							
66	VCC_USBA							
67		P11		MTIC5V/TMC13	SCK2/USBA_VBUS/ USBA_VBUSEN		IRQ1	
68		P10	ALE	MTIC5W/TMR13	USBA_OVRCURA		IRQ0	
69		P53*1	BCLK					
70		P52	RD#		RXD2/SMISO2/ SSCL2/SSLB3-A			
71		P51	WR1#/BC1#/ WAIT#		SCK2/SSLB2-A			
72		P50	WR0#/WR#		TXD2/SMOSI2/ SSDA2/SSLB1-A			
73	VSS							
74		P83	EDACK1	MTIOC4C/ GTIOC0A-D	CTS10#/ET0_CRS/ RMII0_CRS_DV/ SCK10			
75	VCC							
76	UB	PC7	A23/CS0#	MTIOC3A/MTCLKB/ GTIOC3A-D/TMO2/ TOC0/PO31/CACREF	TXD8/MISOA-A/ ET0_COL	MMC_D7-A	IRQ14	
77		PC6	A22/CS1#	MTIOC3C/MTCLKA/ GTIOC3B-D/TMC12/ TIC0/PO30	RXD8/MOSIA-A/ ET0_ETXD3	MMC_D6-A	IRQ13	
78		PC5	A21/CS2#/ WAIT#	MTIOC3B/MTCLKD/ GTIOC1A-D/TMR12/ PO29	SCK8/RSPCKA-A/ RTS8#/ET0_ETXD2	MMC_D5-A		
79		P82	EDREQ1	MTIOC4A/ GTIOC2A-D/PO28	TXD10/ET0_ETXD1/ RMII0_TXD1	MMC_D4-A		
80		P81	EDACK0	MTIOC3D/ GTIOC0B-D/PO27	RXD10/ET0_ETXD0/ RMII0_TXD0	MMC_D3-A/ SDHI_CD-A/ QIO3-A		
81		P80	EDREQ0	MTIOC3B/PO26	SCK10/RTS10#/ ET0_TX_EN/ RMII0_TXD_EN	MMC_D2-A/ SDHI_WP-A/ QIO2-A		
82		PC4	A20/CS3#	MTIOC3D/MTCLKC/ GTETR-D/TMC11/ PO25/POE0#	SCK5/CTS8#/SSLA0- A/ET0_TX_CLK	MMC_D1-A/ SDHI_D1-A/ QIO1-A/QMI-A		
83		PC3	A19	MTIOC4D/ GTIOC1B-D/TCLKB/ PO24	TXD5/SMOSI5/ SSDA5/ ET0_TX_ER	MMC_D0-A/ SDHI_D0-A/ QIO0-A/ QMO-A		

Table 1.6 List of Pin and Pin Functions (176-Pin LQFP) (4/7)

Pin Number	Power Supply Clock System Control	I/O Port	Bus EXDMAC SDRAMC	Timer (MTU, GPT, TPU, TMR, PPG, RTC, CMTW, POE, CAC)	Communication (ETHERC, SC1g, SC1h, RSPI, RIIC, CAN, USB, SSI)	Memory Interface Camera Interface (QSPI, SDHI, MMCIF, PDC)	Interrupt	S12ADC, R12DA
84		P77	CS7#	PO23	TXD11/ET0_RX_ER/ RMII0_RX_ER	MMC_CLK-A/ SDHI_CLK-A/ QSPCLK-A		
85		P76	CS6#	PO22	RXD11/ET0_RX_CLK/ REF50CK0	MMC_CMD-A/ SDHI_CMD-A/ QSSL-A		
86		PC2	A18	MTIOC4B/ GTIOC2B-D/TCLKA/ PO21	RXD5/SMISO5/ SSCL5/SSLA3-A/ ET0_RX_DV	MMC_CD-A/ SDHI_D3-A		
87		P75	CS5#	PO20	SCK11/RTS11#/ ET0_ERXD0/ RMII0_RXD0	MMC_RES#-A/ SDHI_D2-A		
88		P74	A20/CS4#	PO19	CTS11#/ET0_ERXD1/ RMII0_RXD1			
89		PC1	A17	MTIOC3A/TCLKD/ PO18	SCK5/SSLA2-A/ ET0_ERXD2		IRQ12	
90	VCC							
91		PC0	A16	MTIOC3C/TCLKC/ PO17	CTS5#/RTS5#/SS5#/ SSLA1-A/ET0_ERXD3		IRQ14	
92	VSS							
93		P73	CS3#	PO16	ET0_WOL			
94		PB7	A15	MTIOC3B/TIOCB5/ PO31	TXD9/ET0_CRS/ RMII0_CRS_DV			
95		PB6	A14	MTIOC3D/TIOCA5/ PO30	RXD9/ET0_ETXD1/ RMII0_TXD1			
96		PB5	A13	MTIOC2A/MTIOC1B/ TIOCB4/TMR11/PO29/ POE4#	SCK9/RTS9#/ ET0_ETXD0/ RMII0_TXD0			
97		PB4	A12	TIOCA4/PO28	CTS9#/ET0_TX_EN/ RMII0_TXD_EN			
98		PB3	A11	MTIOC0A/MTIOC4A/ TIOCD3/TCLKD/ TMO0/PO27/POE11#	SCK4/SCK6/ ET0_RX_ER/ RMII0_RX_ER			
99		PB2	A10	TIOCC3/TCLKC/ PO26	CTS4#/RTS4#/ CTS6#/ RTS6#/ SS4#/ SS6#/ ET0_RX_CLK/ REF50CK0			
100		PB1	A9	MTIOC0C/MTIOC4C/ TIOCB3/TMCI0/PO25	TXD4/TXD6/SMOSI4/ SMOSI6/SSDA4/ SSDA6/ET0_ERXD0/ RMII0_RXD0		IRQ4-DS	
101		P72	A19/CS2#		ET0_MDC			
102		P71	A18/CS1#		ET0_MDIO			
103	VCC							
104		PB0	A8	MTIC5W/TIOCA3/ PO24	RXD4/RXD6/SMISO4/ SMISO6/SSCL4/ SSCL6/ET0_ERXD1/ RMII0_RXD1		IRQ12	
105	VSS							
106		PA7	A7	TIOCB2/PO23	MISOA-B/ ET0_WOL			
107		PA6	A6	MTIC5V/MTCLKB/ GTETR-C/TIOCA2/ TMCI3/PO22/POE10#	CTS5#/RTS5#/ SS5#/ MOSIA-B/ ET0_EXOUT			
108		PA5	A5	MTIOC6B/ GTIOC0A-C/TIOCB1/ PO21	RSPCKA-B/ ET0_LINKSTA			
109		PA4	A4	MTIC5U/MTCLKA/ TIOCA1/TMRI0/PO20	TXD5/SMOSI5/ SSDA5/SSLA0-B/ ET0_MDC		IRQ5-DS	

Table 1.6 List of Pin and Pin Functions (176-Pin LQFP) (5/7)

Pin Number	Power Supply Clock System Control	I/O Port	Bus EXDMAC SDRAMC	Timer (MTU, GPT, TPU, TMR, PPG, RTC, CMTW, POE, CAC)	Communication (ETHERC, SC1g, SC1h, RSPI, RIIC, CAN, USB, SSI)	Memory Interface Camera Interface (QSPI, SDHI, MMCIF, PDC)	Interrupt	S12ADC, R12DA
110		PA3	A3	MTIIOC0D/MTCLKD/TIIOC0D/TCLKB/PO19	RXD5/SMISO5/SSCL5/ET0_MDIO		IRQ6-DS	
111	TRDATA3	PG7	D31		ET1_TX_ER			
112		PA2	A2	MTIIOC7A/GTIIOC1A-C/PO18	RXD5/SMISO5/SSCL5/SSLA3-B			
113	TRDATA2	PG6	D30		ET1_ETXD3			
114		PA1	A1/DQM3	MTIIOC0B/MTCLKC/MTIIOC7B/GTIIOC2A-C/TIIOC0B/PO17	SCK5/SSLA2-B/ET0_WOL		IRQ11	
115	VCC							
116	TRCLK	PG5	D29		ET1_ETXD2			
117	VSS							
118		PA0	A0/BC0#/DQM2	MTIIOC4A/MTIIOC6D/GTIIOC0B-C/TIIOC0A0/CACREF/PO16	SSLA1-B/ET0_TX_EN/RMII0_TXD_EN			
119	TRSYNC	PG4	D28		ET1_ETXD1/RMII1_TXD1			
120		P67	CS7#/DQM1	MTIIOC7C/GTIIOC1B-C	CRX2		IRQ15	
121	TRDATA1	PG3	D27		ET1_ETXD0/RMII1_TXD0			
122		P66	CS6#/DQM0	MTIIOC7D/GTIIOC2B-C	CTX2			
123	TRDATA0	PG2	D26		ET1_TX_CLK			
124		P65	CS5#/CKE					
125		PE7	D15[A15/D15]	MTIIOC6A/GTIIOC3A-E/TOC1	MISOB-B	MMC_RES#-B/SDHI_WP-B	IRQ7	AN105
126		PE6	D14[A14/D14]	MTIIOC6C/GTIIOC3B-E/TIC1	MOSIB-B	MMC_CD-B/SDHI_CD-B	IRQ6	AN104
127	VCC							
128		P70	SDCLK					
129	VSS							
130		PE5	D13[A13/D13]	MTIIOC4C/MTIIOC2B/GTIIOC0A-A	ET0_RX_CLK/REF50CK0/RSPCKB-B		IRQ5	AN103
131		PE4	D12[A12/D12]	MTIIOC4D/MTIIOC1A/GTIIOC1A-A/PO28	ET0_ERXD2/SSLB0-B			AN102
132		PE3	D11[A11/D11]	MTIIOC4B/GTIIOC2A-A/PO26/POE8#/TOC3	CTS12#/RTS12#/SS12#/ET0_ERXD3	MMC_D7-B		AN101
133		PE2	D10[A10/D10]	MTIIOC4A/GTIIOC0B-A/PO23/TIC3	RXD12/SMISO12/SSCL12/RXDX12/SSLB3-B	MMC_D6-B	IRQ7-DS	AN100
134		PE1	D9[A9/D9]	MTIIOC4C/MTIIOC3B/GTIIOC1B-A/PO18	TXD12/SMOSI12/SSDA12/TXDX12/SIOX12/SSLB2-B	MMC_D5-B		ANEX1
135		PE0	D8[A8/D8]	MTIIOC3D/GTIIOC2B-A	SCK12/SSLB1-B	MMC_D4-B		ANEX0
136		P64	CS4#/WE#					
137		P63	CS3#/CAS#					
138		P62	CS2#/RAS#					
139		P61	CS1#/SDCS#					
140	VSS							

Table 1.6 List of Pin and Pin Functions (176-Pin LQFP) (6/7)

Pin Number	Power Supply Clock System Control	I/O Port	Bus EXDMAC SDRAMC	Timer (MTU, GPT, TPU, TMR, PPG, RTC, CMTW, POE, CAC)	Communication (ETHERC, SC1g, SC1h, RSPI, RIIC, CAN, USB, SSI)	Memory Interface Camera Interface (QSPI, SDHI, MMCIF, PDC)	Interrupt	S12ADC, R12DA
141		P60	CS0#		ET1_TX_EN/ RMII1_TXD_EN			
142	VCC							
143		PD7	D7[A7/D7]	MTIC5U/POE0#		MMC_D1-B/ SDHI_D1-B/ QIO1-B/QMI-B	IRQ7	AN107
144		PG1	D25		ET1_RX_ER/ RMII1_RX_ER			
145		PD6	D6[A6/D6]	MTIC5V/MTIOC8A/ POE4#		MMC_D0-B/ SDHI_D0-B/ QIO0-B/ QMO-B	IRQ6	AN106
146		PG0	D24		ET1_RX_CLK/ REF50CK1			
147		PD5	D5[A5/D5]	MTIC5W/MTIOC8C/ POE10#		MMC_CLK-B/ SDHI_CLK-B/ QSPCLK-B	IRQ5	AN113
148		PD4	D4[A4/D4]	MTIOC8B/POE11#		MMC_CMD-B/ SDHI_CMD-B/ QSSL-B	IRQ4	AN112
149		P97	A23/D23		ET1_ERXD3			
150		PD3	D3[A3/D3]	MTIOC8D/ GTIOC0A-E/POE8#/ TOC2		MMC_D3-B/ SDHI_D3-B/ QIO3-B	IRQ3	AN111
151	VSS							
152		P96	A22/D22		ET1_ERXD2			
153	VCC							
154		PD2	D2[A2/D2]	MTIOC4D/ GTIOC0B-E/TIC2	CRX0	MMC_D2-B/ SDHI_D2-B/ QIO2_B	IRQ2	AN110
155		P95	A21/D21		ET1_ERXD1/ RMII1_RXD1			
156		PD1	D1[A1/D1]	MTIOC4B/ GTIOC1A-E/POE0#	CTX0		IRQ1	AN109
157		P94	A20/D20		ET1_ERXD0/ RMII1_RXD0			
158		PD0	D0[A0/D0]	GTIOC1B-E/POE4#			IRQ0	AN108
159		P93	A19/D19	POE0#	ET1_LINKSTA/CTS7#/ RTS7#/SS7#			AN117
160		P92	A18/D18	POE4#	ET1_CRS/ RMII1_CRS_DV/ RXD7/SMISO7/SSCL7			AN116
161		P91	A17/D17		ET1_COL/SCK7			AN115
162	VSS							
163		P90	A16/D16		ET1_RX_DV/ TXD7/SMOSI7/SSDA7			AN114
164	VCC							
165		P47					IRQ15- DS	AN007
166		P46					IRQ14- DS	AN006
167		P45					IRQ13- DS	AN005
168		P44					IRQ12- DS	AN004
169		P43					IRQ11-DS	AN003
170		P42					IRQ10- DS	AN002

Table 1.6 List of Pin and Pin Functions (176-Pin LFQFP) (7/7)

Pin Number	Power Supply Clock System Control	I/O Port	Bus EXDMAC SDRAMC	Timer (MTU, GPT, TPU, TMR, PPG, RTC, CMTW, POE, CAC)	Communication (ETHERC, SC1g, SC1h, RSPI, RIIC, CAN, USB, SSI)	Memory Interface Camera Interface (QSPI, SDHI, MMCIF, PDC)	Interrupt	S12ADC, R12DA
171		P41					IRQ9-DS	AN001
172	VREFL0							
173		P40					IRQ8-DS	AN000
174	VREFH0							
175	AVCC0							
176		P07					IRQ15	ADTRG0#

Note 1. The BCLK function is multiplexed with the I/O port function for pin P53, so the port function is not available if the external bus is enabled.

Table 1.7 List of Pin and Pin Functions (145-Pin TFLGA) (1/5)

Pin Number	Power Supply Clock System Control	I/O Port	Bus EXDMAC SDRAMC	Timer (MTU, GPT, TPU, TMR, PPG, RTC, CMTW, POE, CAC)	Communication (ETHERC, SC1g, SC1h, RSPI, RIIC, CAN, USB, SSI)	Memory Interface Camera Interface (QSPI, SDHI, MMCIF, PDC)	Interrupt	S12ADC, R12DA
A1	AVSS0							
A2		P07					IRQ15	ADTRG0#
A3		P40					IRQ8-DS	AN000
A4		P42					IRQ10-DS	AN002
A5		P45					IRQ13-DS	AN005
A6		P90	A16		TXD7/SMOSI7/SSDA7			AN114
A7		P92	A18	POE4#	RXD7/SMISO7/SSCL7			AN116
A8		PD2	D2[A2/D2]	MTIOC4D/ GTIOC0B-E/TIC2	CRX0	MMC_D2-B/ SDHI_D2-B/ QIO2-B	IRQ2	AN110
A9		PD6	D6[A6/D6]	MTIC5V/MTIOC8A/ POE4#		MMC_D0-B/ SDHI_D0-B/ QIO0-B/ QMO-B	IRQ6	AN106
A10	VSS							
A11		P62	CS2#/RAS#					
A12		PE1	D9[A9/D9]	MTIOC4C/MTIOC3B/ GTIOC1B-A/PO18	TXD12/SMOSI12/ SSDA12/TXDX12/ SIOX12/SSLB2-B	MMC_D5-B		ANEX1
A13		PE3	D11[A11/D11]	MTIOC4B/ GTIOC2A-A/PO26/ POE8#/TOC3	CTS12#/RTS12#/ SS12#/ET0_ERXD3/	MMC_D7-B		AN101
B1	AVCC1							
B2	AVCC0							
B3		P05					IRQ13	DA1
B4	VREFL0							
B5		P43					IRQ11-DS	AN003
B6		P47					IRQ15-DS	AN007
B7		P91	A17		SCK7			AN115
B8		PD0	D0[A0/D0]	GTIOC1B-E/POE4#			IRQ0	AN108
B9		PD4	D4[A4/D4]	MTIOC8B/POE11#		MMC_CMD-B/ SDHI_CMD-B/ QSSL-B	IRQ4	AN112
B10	VCC							
B11		P61	CS1#/SDCS#					
B12		PE2	D10[A10/D10]	MTIOC4A/ GTIOC0B-A/PO23/ TIC3	RXD12/SMISO12/ SSCL12/RXDX12/ SSLB3-B	MMC_D6-B	IRQ7-DS	AN100
B13		PE4	D12[A12/D12]	MTIOC4D/MTIOC1A/ GTIOC1A-A/PO28	ET0_ERXD2/SSLB0-B			AN102
C1	AVSS1							
C2		P02		TMCI1	SCK6		IRQ10	AN120
C3	VREFH0							
C4		P41					IRQ9-DS	AN001
C5		P46					IRQ14-DS	AN006
C6	VSS							
C7		PD1	D1[A1/D1]	MTIOC4B/ GTIOC1A-E/POE0#	CTX0		IRQ1	AN109
C8		PD3	D3[A3/D3]	MTIOC8D/ GTIOC0A-E/POE8#/ TOC2		MMC_D3-B/ SDHI_D3-B/ QIO3-B	IRQ3	AN111

Table 1.7 List of Pin and Pin Functions (145-Pin TFLGA) (2/5)

Pin Number	Power Supply Clock System Control	I/O Port	Bus EXDMAC SDRAMC	Timer (MTU, GPT, TPU, TMR, PPG, RTC, CMTW, POE, CAC)	Communication (ETHERC, SC1g, SC1h, RSPI, RIIC, CAN, USB, SSI)	Memory Interface Camera Interface (QSPI, SDHI, MMCIF, PDC)	Interrupt	S12ADC, R12DA
C9		PD7	D7[A7/D7]	MTIC5U/POE0#		MMC_D1-B/ SDHI_D1-B/ QIO1-B/QMI-B	IRQ7	AN107
C10		P63	CS3#/CAS#					
C11		PE0	D8[A8/D8]	MTIOC3D/ GTIOC2B-A	SCK12/SSLB1-B	MMC_D4-B		ANEX0
C12		P70	SDCLK					
C13	VSS							
D1		P00		TMR10	TXD6/SMISO6/SSDA6		IRQ8	AN118
D2		PF5					IRQ4	
D3		P03					IRQ11	DA0
D4		P01		TMC10	RXD6/SMISO6/SSCL6		IRQ9	AN119
D5	VCC							
D6		P93	A19	POE0#	CTS7#/RTS7#/SS7#			AN117
D7		PD5	D5[A5/D5]	MTIC5W/MTIOC8C/ POE10#		MMC_CLK-B/ SDHI_CLK-B/ QSPCLK-B	IRQ5	AN113
D8		P60	CS0#					
D9		P64	CS4#/WE#					
D10		PE7	D15[A15/D15]	MTIOC6A/ GTIOC3A-E/TOC1	MISOB-B	MMC_RES#-B/ SDHI_WP-B	IRQ7	AN105
D11	VCC							
D12		PE5	D13[A13/D13]	MTIOC4C/MTIOC2B/ GTIOC0A-A	ET0_RX_CLK/ REF50CK0/ RSPCKB-B		IRQ5	AN103
D13		PE6	D14[A14/D14]	MTIOC6C/GTIOC3B- E/TIC1	MOSIB-B	MMC_CD-B/ SDHI_CD-B	IRQ6	AN104
E1	VSS							
E2	VCL							
E3		PJ5		POE8#	CTS2#/RTS2#/SS2#			
E4	EMLE							
E5		P44					IRQ12- DS	AN004
E10		PA0	A0/BC0#	MTIOC4A/MTIOC6D/ GTIOC0B-C/TIOCA0/ CACREF/PO16	SSLA1-B/ ET0_TX_EN/ RMII0_TXD_EN			
E11		P66	CS6#/DQM0	MTIOC7D/ GTIOC2B-C	CTX2			
E12		P65	CS5#/CKE					
E13		P67	CS7#/DQM1	MTIOC7C/ GTIOC1B-C	CRX2		IRQ15	
F1	XCIN							
F2	XCOUT							
F3		PJ3	EDACK1	MTIOC3C	ET0_EXOUT/CTS6#/ RTS6#/CTS0#/RTS0#/ SS6#/SS0#			
F4	VBATT							
F10		PA3	A3	MTIOC0D/MTCLKD/ TIOC0D/TCLKB/PO19	RXD5/SMISO5/ SSCL5/ET0_MDIO		IRQ6-DS	
F11	VSS							
F12		PA1	A1	MTIOC0B/MTCLKC/ MTIOC7B/ GTIOC2A-C/TIOC0B/ PO17	SCK5/SSLA2-B/ ET0_WOL		IRQ11	

Table 1.7 List of Pin and Pin Functions (145-Pin TFLGA) (3/5)

Pin Number	Power Supply Clock System Control	I/O Port	Bus EXDMAC SDRAMC	Timer (MTU, GPT, TPU, TMR, PPG, RTC, CMTW, POE, CAC)	Communication (ETHERC, SC1g, SC1h, RSPI, RIIC, CAN, USB, SSI)	Memory Interface Camera Interface (QSPI, SDHI, MMCIF, PDC)	Interrupt	S12ADC, R12DA
F13		PA2	A2	MTIOC7A/ GTIOC1A-C/PO18	RXD5/SMISO5/ SSCL5/SSLA3-B			
G1	XTAL	P37						
G2	RES							
G3	MD/FINED							
G4	BSCANP							
G10		PA5	A5	MTIOC6B/TIOCB1/ GTIOC0A-C/PO21	RSPCKA-B/ ET0_LINKSTA			
G11		PA6	A6	MTIC5V/MTCLKB/ GTETRGC-C/TIOCA2/ TMC13/PO22/POE10#	CTS5#/RTS5#/SS5#/ MOSIA-B/ ET0_EXOUT			
G12	VCC							
G13		PA4	A4	MTIC5U/MTCLKA/ TIOCA1/TMRI0/PO20	TXD5/SMOSI5/ SSDA5/SSLA0-B/ ET0_MDC		IRQ5-DS	
H1	EXTAL	P36						
H2	VCC							
H3	VSS							
H4	UPSEL	P35					NMI	
H10		P72	A19/CS2#		ET0_MDC			
H11		P71	A18/CS1#		ET0_MDIO			
H12		PB0	A8	MTIC5W/TIOCA3/ PO24	RXD4/RXD6/SMISO4/ SMISO6/SSCL4/ SSCL6/ET0_ERXD1/ RMII0_RXD1		IRQ12	
H13		PA7	A7	TIOCB2/PO23	MISOA-B/ET0_WOL			
J1	TRST#	P34		MTIOC0A/TMC13/ PO12/POE10#	SCK6/SCK0/ ET0_LINKSTA		IRQ4	
J2		P33	EDREQ1	MTIOC0D/TIOC0D/ TMRI3/PO11/POE4#/ POE11#	RXD6/RXD0/SMISO6/ SMISO0/SSCL6/ SSCL0/CRX0	PCKO	IRQ3-DS	
J3		P32		MTIOC0C/TIOCC0/ TMO3/PO10/ RTCOUT/RTCIC2/ POE0#/POE10#	TXD6/TXD0/SMOSI6/ SMOSI0/SSDA6/ SSDA0/CTX0/ USB0_VBUSEN	VSYNC	IRQ2-DS	
J4	TDI	P30		MTIOC4B/TMRI3/ PO8/RTCIC0/POE8#	RXD1/SMISO1/ SSCL1/MISOB-A		IRQ0-DS	
J10		PB3	A11	MTIOC0A/MTIOC4A/ TIOC03/TCLKD/ TMO0/PO27/POE11#	SCK4/SCK6/ ET0_RX_ER/ RMII0_RX_ER			
J11		PB4	A12	TIOCA4/PO28	CTS9#/ET0_TX_EN/ RMII0_TXD_EN			
J12		PB2	A10	TIOCC3/TCLKC/ PO26	CTS4#/RTS4#/CTS6#/ RTS6#/SS4#/SS6#/ ET0_RX_CLK/ REF50CK0			
J13		PB1	A9	MTIOC0C/MTIOC4C/ TIOCB3/TMC10/PO25	TXD4/TXD6/SMOSI4/ SMOSI6/SSDA4/ SSDA6/ET0_ERXD0/ RMII0_RXD0		IRQ4-DS	
K1	TCK	P27	CS7#	MTIOC2B/TMC13/PO7	SCK1/RSPCKB-A			
K2	TDO	P26	CS6#	MTIOC2A/TMO1/PO6	TXD1/CTS3#/RTS3#/ SMOSI1/SS3#/ SSDA1/MOSIB-A			
K3	TMS	P31		MTIOC4D/TMC12/ PO9/RTCIC1	CTS1#/RTS1#/SS1#/ SSLB0-A		IRQ1-DS	

Table 1.7 List of Pin and Pin Functions (145-Pin TFLGA) (4/5)

Pin Number	Power Supply Clock System Control	I/O Port	Bus EXDMAC SDRAMC	Timer (MTU, GPT, TPU, TMR, PPG, RTC, CMTW, POE, CAC)	Communication (ETHERC, SC1g, SC1h, RSPI, RIIC, CAN, USB, SSI)	Memory Interface Camera Interface (QSPI, SDHI, MMCIF, PDC)	Interrupt	S12ADC, R12DA
K4		P15		MTIOC0B/MTCLKB/ GTETRG-B/TIOC2B/ TCLKB/TMC12/PO13	RXD1/SCK3/SMISO1/ SSCL1/CRX1-DS/ SSIWS1	PIXD0	IRQ5	
K5	TRDATA2	P54	ALE/EDACK0	MTIOC4B/TMC11	CTS2#/RTS2#/SS2#/ CTX1/ET0_LINKSTA			
K6		P53*1	BCLK					
K7		P51	WR1#/BC1#/ WAIT#		SCK2/SSLB2-A			
K8	VCC							
K9	TRDATA0	P80	EDREQ0	MTIOC3B/PO26	SCK10/RTS10#/ ET0_TX_EN/ RMII0_TXD_EN	MMC_D2-A/ SDHI_WP-A/ QIO2-A		
K10		P76	CS6#	PO22	RXD11/ET0_RX_CLK/ REF50CK0	MMC_CMD-A/ SDHI_CMD-A/ QSSL-A		
K11		PB7	A15	MTIOC3B/TIOCB5/ PO31	TXD9/ET0_CRS/ RMII0_CRS_DV			
K12		PB6	A14	MTIOC3D/TIOCA5/ PO30	RXD9/ET0_ETXD1/ RMII0_TXD1			
K13		PB5	A13	MTIOC2A/MTIOC1B/ TIOCB4/TMR11/PO29/ POE4#	SCK9/RTS9#/ ET0_ETXD0/ RMII0_TXD0			
L1		P25	CS5#/ EDACK1	MTIOC4C/MTCLKB/ TIOCA4/PO5	RXD3/SMISO3/ SSCL3/SSIDATA1	HSYNC		ADTRG0#
L2		P23	EDACK0	MTIOC3D/MTCLKD/ GTIOC0A-B/TIOCD3/ PO3	TXD3/CTS0#/RTS0#/ SMOSI3/SS0#/ SSDA3/SSISCK0	PIXD7		
L3		P16		MTIOC3C/MTIOC3D/ TIOCB1/TCLKC/ TMO2/PO14/ RTCOUT	TXD1/RXD3/SMOSI1/ SMISO3/SSDA1/ SSCL3/SCL2-DS/ USB0_VBUS/ USB0_VBUSEN/ USB0_OVRCURB		IRQ6	ADTRG0#
L4		P24	CS4#/ EDREQ1	MTIOC4A/MTCLKA/ TIOCB4/TMR11/PO4	SCK3/ USB0_VBUSEN/ SSISCK1	PIXCLK		
L5		P13		MTIOC0B/TIOCA5/ TMO3/PO13	TXD2/SMOSI2/ SSDA2/SDA0[FM+]		IRQ3	ADTRG1#
L6		P56	EDACK1	MTIOC3C/TIOCA1				
L7		P52	RD#		RXD2/SMISO2/ SSCL2/SSLB3-A			
L8	TRCLK	P83	EDACK1	MTIOC4C/ GTIOC0A-D	CTS10#/ET0_CRS/ RMII0_CRS_DV/ SCK10			
L9		PC5	A21/CS2#/ WAIT#	MTIOC3B/MTCLKD/ GTIOC1A-D/TMR12/ PO29	SCK8/RSPCKA-A/ RTS8#/ET0_ETXD2	MMC_D5-A		
L10		PC4	A20/CS3#	MTIOC3D/MTCLKC/ GTETRG-D/TMC11/ PO25/POE0#	SCK5/CTS8#/ SSLA0-A/ ET0_TX_CLK	MMC_D1-A/ SDHI_D1-A/ QIO1-A/QMI-A		
L11		PC2	A18	MTIOC4B/ GTIOC2B-D/TCLKA/ PO21	RXD5/SMISO5/ SSCL5/SSLA3-A/ ET0_RX_DV	MMC_CD-A/ SDHI_D3-A		
L12		P73	CS3#	PO16	ET0_WOL			
L13	VSS							
M1		P22	EDREQ0	MTIOC3B/MTCLKC/ GTIOC1A-B/TIOCC3/ TMO0/PO2	SCK0/ USB0_OVRCURB/ AUDIO_MCLK	PIXD6		

Table 1.7 List of Pin and Pin Functions (145-Pin TFLGA) (5/5)

Pin Number	Power Supply Clock System Control	I/O Port	Bus EXDMAC SDRAMC	Timer (MTU, GPT, TPU, TMR, PPG, RTC, CMTW, POE, CAC)	Communication (ETHERC, SC1g, SC1h, RSPI, RIIC, CAN, USB, SSI)	Memory Interface Camera Interface (QSPI, SDHI, MMCIF, PDC)	Interrupt	S12ADC, R12DA
M2		P17		MTIOC3A/MTIOC3B/MTIOC4B/GTIOC0B-B/TIOC0B0/TCLKD/TMO1/PO15/POE8#	SCK1/TXD3/SMOSI3/SSDA3/SDA2-DS/SSITXD0	PIXD3	IRQ7	ADTRG1#
M3		P86		MTIOC4D/GTIOC2B-B/TIOCA0	RXD10	PIXD1		
M4		P12		TMCI1	RXD2/SMISO2/SSCL2/SCL0[FM+]		IRQ2	
M5	VCC_USB							
M6	VSS_USB							
M7		P50	WR0#/WR#		TXD2/SMOSI2/SSDA2/SSLB1-A			
M8		PC6	A22/CS1#	MTIOC3C/MTCLKA/GTIOC3B-D/TMCI2/TIC0/PO30	RXD8/MOSIA-A/ET0_ETXD3	MMC_D6-A	IRQ13	
M9	TRDATA1	P81	EDACK0	MTIOC3D/GTIOC0B-D/PO27	RXD10/ET0_ETXD0/RMII0_TXD0	MMC_D3-A/SDHI_CD-A/QIO3-A		
M10		P77	CS7#	PO23	TXD11/ET0_RX_ER/RMII0_RX_ER	MMC_CLK-A/SDHI_CLK-A/QSPCLK-A		
M11		PC0	A16	MTIOC3C/TCLKC/PO17	CTS5#/RTS5#/SS5#/SSLA1-A/ET0_ERXD3		IRQ14	
M12		PC1	A17	MTIOC3A/TCLKD/PO18	SCK5/SSLA2-A/ET0_ERXD2		IRQ12	
M13	VCC							
N1		P21		MTIOC1B/MTIOC4A/GTIOC2A-B/TIOCA3/TMCI0/PO1	RXD0/SMISO0/SSCL0/USB0_EXICEN/SSIWS0	PIXD5	IRQ9	
N2		P20		MTIOC1A/TIOC0B3/TMRI0/PO0	TXD0/SMOSI0/SSDA0/USB0_ID/SSIRXD0	PIXD4	IRQ8	
N3		P87		MTIOC4C/GTIOC1B-B/TIOCA2	TXD10	PIXD2		
N4		P14		MTIOC3A/MTCLKA/TIOC0B5/TCLKA/TMRI2/PO15	CTS1#/RTS1#/SS1#/CTX1/USB0_OVRCURA		IRQ4	
N5					USB0_DM			
N6					USB0_DP			
N7	TRDATA3	P55	WAIT#/EDREQ0	MTIOC4D/TMO3	CRX1/ET0_EXOUT		IRQ10	
N8	VSS							
N9	UB	PC7	A23/CS0#	MTIOC3A/MTCLKB/GTIOC3A-D/TMO2/TOC0/PO31/CACREF	TXD8/MISOA-A/ET0_COL	MMC_D7-A	IRQ14	
N10	TRSYNC	P82	EDREQ1	MTIOC4A/GTIOC2A-D/PO28	TXD10/ET0_ETXD1/RMII0_TXD1	MMC_D4-A		
N11		PC3	A19	MTIOC4D/GTIOC1B-D/TCLKB/PO24	TXD5/SMOSI5/SSDA5/ET0_TX_ER	MMC_D0-A/SDHI_D0-A/QIO0-A/QMO-A		
N12		P75	CS5#	PO20	SCK11/RTS11#/ET0_ERXD0/RMII0_RXD0	MMC_RES#-A/SDHI_D2-A		
N13		P74	A20/CS4#	PO19	CTS11#/ET0_ERXD1/RMII0_RXD1			

Note 1. The BCLK function is multiplexed with the I/O port function for pin P53, so the port function is not available if the external bus is enabled.

Table 1.8 List of Pin and Pin Functions (144-Pin LQFP) (1/5)

Pin Number	Power Supply Clock System Control	I/O Port	Bus EXDMAC SDRAMC	Timer (MTU, GPT, TPU, TMR, PPG, RTC, CMTW, POE, CAC)	Communication (ETHERC, SC1g, SC1h, RSPI, RIIC, CAN, USB, SSI)	Memory Interface Camera Interface (QSPI, SDHI, MMCIF, PDC)	Interrupt	S12ADC, R12DA
1	AVSS0							
2		P05					IRQ13	DA1
3	AVCC1							
4		P03					IRQ11	DA0
5	AVSS1							
6		P02		TMCI1	SCK6		IRQ10	AN120
7		P01		TMCI0	RXD6/SMISO6/SSCL6		IRQ9	AN119
8		P00		TMRI0	TXD6/SMOSI6/SSDA6		IRQ8	AN118
9		PF5					IRQ4	
10	EMLE							
11		PJ5		POE8#	CTS2#/RTS2#/SS2#			
12	VSS							
13		PJ3	EDACK1	MTIOC3C	ET0_EXOUT/CTS6#/ RTS6#/CTS0#/RTS0#/ SS6#/SS0#			
14	VCL							
15	VBATT							
16	MD/FINED							
17	XCIN							
18	XCOUT							
19	RES							
20	XTAL	P37						
21	VSS							
22	EXTAL	P36						
23	VCC							
24		P35					NMI	
25	TRST#	P34		MTIOC0A/TMCI3/ PO12/POE10#	SCK6/SCK0/ ET0_LINKSTA		IRQ4	
26		P33	EDREQ1	MTIOC0D/TIOCD0/ TMRI3/PO11/POE4#/ POE11#	RXD6/RXD0/SMISO6/ SMISO0/SSCL6/ SSCL0/CRX0	PCKO	IRQ3-DS	
27		P32		MTIOC0C/TIOCC0/ TMO3/PO10/ RTCOUT/RTCIC2/ POE0#/POE10#	TXD6/TXD0/SMOSI6/ SMOSI0/SSDA6/ SSDA0/CTX0/ USB0_VBUSEN	VSYN	IRQ2-DS	
28	TMS	P31		MTIOC4D/TMCI2/ PO9/RTCIC1	CTS1#/RTS1#/SS1#/ SSLB0-A		IRQ1-DS	
29	TDI	P30		MTIOC4B/TMRI3/ PO8/RTCIC0/POE8#	RXD1/SMISO1/ SSCL1/MISOB-A		IRQ0-DS	
30	TCK	P27	CS7#	MTIOC2B/TMCI3/PO7	SCK1/RSPCKB-A			
31	TDO	P26	CS6#	MTIOC2A/TMO1/PO6	TXD1/CTS3#/RTS3#/ SMOSI1/SS3#/ SSDA1/MOSIB-A			
32		P25	CS5#/ EDACK1	MTIOC4C/MTCLKB/ TIOCA4/PO5	RXD3/SMISO3/ SSCL3/SSDATA1	HSYN		ADTRG0#
33		P24	CS4#/ EDREQ1	MTIOC4A/MTCLKA/ TIOCB4/TMRI1/PO4	SCK3/ USB0_VBUSEN/ SSISCK1	PIXCLK		
34		P23	EDACK0	MTIOC3D/MTCLKD/ GTIOC0A-B/TIOCD3/ PO3	TXD3/CTS0#/RTS0#/ SMOSI3/SS0#/ SSDA3/SSISCK0	PIXD7		
35		P22	EDREQ0	MTIOC3B/MTCLKC/ GTIOC1A-B/TIOCC3/ TMO0/PO2	SCK0/ USB0_OVRCURB/ AUDIO_MCLK	PIXD6		

Table 1.8 List of Pin and Pin Functions (144-Pin LQFP) (2/5)

Pin Number	Power Supply Clock System Control	I/O Port	Bus EXDMAC SDRAMC	Timer (MTU, GPT, TPU, TMR, PPG, RTC, CMTW, POE, CAC)	Communication (ETHERC, SC1g, SC1h, RSPI, RIIC, CAN, USB, SSI)	Memory Interface Camera Interface (QSPI, SDHI, MMCIF, PDC)	Interrupt	S12ADC, R12DA
36		P21		MTIOC1B/MTIOC4A/ GTIOC2A-B/TIOCA3/ TMCI0/PO1	RXD0/SMISO0/ SSCL0/ USB0_EXICEN/ SSIWS0	PIXD5	IRQ9	
37		P20		MTIOC1A/TIOC3B/ TMRI0/PO0	TXD0/SMOSI0/ SSDA0/USB0_ID/ SSIRXD0	PIXD4	IRQ8	
38		P17		MTIOC3A/MTIOC3B/ MTIOC4B/ GTIOC0B-B/TIOC3B/ TCLKD/TMO1/PO15/ POE8#	SCK1/TXD3/SMOSI3/ SSDA3/SDA2-DS/ SSITXD0	PIXD3	IRQ7	ADTRG1#
39		P87		MTIOC4C/ GTIOC1B-B/TIOCA2	TXD10	PIXD2		
40		P16		MTIOC3C/MTIOC3D/ TIOC3B1/TCLKC/ TMO2/PO14/ RTCOUT	TXD1/RXD3/SMOSI1/ SMISO3/SSDA1/ SSCL3/SCL2-DS/ USB0_VBUS/ USB0_VBUSEN/ USB0_OVRCURB		IRQ6	ADTRG0#
41		P86		MTIOC4D/ GTIOC2B-B/TIOCA0	RXD10	PIXD1		
42		P15		MTIOC0B/MTCLKB/ GTETR-G/TIOC3B/ TCLKB/TMCI2/PO13	RXD1/SCK3/SMISO1/ SSCL1/CRX1-DS/ SSIWS1	PIXD0	IRQ5	
43		P14		MTIOC3A/MTCLKA/ TIOC3B5/TCLKA/ TMRI2/PO15	CTS1#/RTS1#/SS1#/ CTX1/ USB0_OVRCURA		IRQ4	
44		P13		MTIOC0B/TIOCA5/ TMO3/PO13	TXD2/SMOSI2/ SSDA2/SDA0[FM+]		IRQ3	ADTRG1#
45		P12		TMCI1	RXD2/SMISO2/ SSCL2/SCL0[FM+]		IRQ2	
46	VCC_USB							
47					USB0_DM			
48					USB0_DP			
49	VSS_USB							
50		P56	EDACK1	MTIOC3C/TIOCA1				
51	TRDATA3	P55	WAIT#/ EDREQ0	MTIOC4D/TMO3	CRX1/ET0_EXOUT		IRQ10	
52	TRDATA2	P54	ALE/EDACK0	MTIOC4B/TMCI1	CTS2#/RTS2#/SS2#/ CTX1/ET0_LINKSTA			
53		P53*1	BCLK					
54		P52	RD#		RXD2/SMISO2/ SSCL2/SSLB3-A			
55		P51	WR1#/BC1#/ WAIT#		SCK2/SSLB2-A			
56		P50	WRO#/WR#		TXD2/SMOSI2/ SSDA2/SSLB1-A			
57	VSS							
58	TRCLK	P83	EDACK1	MTIOC4C/ GTIOC0A-D	CTS10#/ET0_CRS/ RMII0_CRS_DV/ SCK10			
59	VCC							
60	UB	PC7	A23/CS0#	MTIOC3A/MTCLKB/ GTIOC3A-D/TMO2/ TOC0/PO31/CACREF	TXD8/MISOA-A/ ET0_COL	MMC_D7-A	IRQ14	
61		PC6	A22/CS1#	MTIOC3C/MTCLKA/ GTIOC3B-D/TMCI2/ TIC0/PO30	RXD8/MOSIA-A/ ET0_ETXD3	MMC_D6-A	IRQ13	

Table 1.8 List of Pin and Pin Functions (144-Pin LFQFP) (3/5)

Pin Number	Power Supply Clock System Control	I/O Port	Bus EXDMAC SDRAMC	Timer (MTU, GPT, TPU, TMR, PPG, RTC, CMTW, POE, CAC)	Communication (ETHERC, SC1g, SC1h, RSPI, RIIC, CAN, USB, SSI)	Memory Interface Camera Interface (QSPI, SDHI, MMCIF, PDC)	Interrupt	S12ADC, R12DA
62		PC5	A21/CS2#/WAIT#	MTIOC3B/MTCLKD/GTIOC1A-D/TMRI2/PO29	SCK8/RSPCKA-A/RTS8#/ET0_ETXD2	MMC_D5-A		
63	TRSYNC	P82	EDREQ1	MTIOC4A/GTIOC2A-D/PO28	TXD10/ET0_ETXD1/RMII0_TXD1	MMC_D4-A		
64	TRDATA1	P81	EDACK0	MTIOC3D/GTIOC0B-D/PO27	RXD10/ET0_ETXD0/RMII0_TXD0	MMC_D3-A/SDHI_CD-A/QIO3-A		
65	TRDATA0	P80	EDREQ0	MTIOC3B/PO26	SCK10/RTS10#/ET0_TX_EN/RMII0_TXD_EN	MMC_D2-A/SDHI_WP-A/QIO2-A		
66		PC4	A20/CS3#	MTIOC3D/MTCLKC/GTETR-D/TMCI1/PO25/POE0#	SCK5/CTS8#/SSLA0-A/ET0_TX_CLK/	MMC_D1-A/SDHI_D1-A/QIO1-A/QMI-A		
67		PC3	A19	MTIOC4D/GTIOC1B-D/TCLKB/PO24	TXD5/SMOSI5/SSDA5/ET0_TX_ER	MMC_D0-A/SDHI_D0-A/QIO0-A/QMO-A		
68		P77	CS7#	PO23	TXD11/ET0_RX_ER/RMII0_RX_ER	MMC_CLK-A/SDHI_CLK-A/QSPCLK-A		
69		P76	CS6#	PO22	RXD11/ET0_RX_CLK/REF50CK0	MMC_CMD-A/SDHI_CMD-A/QSSL-A		
70		PC2	A18	MTIOC4B/GTIOC2B-D/TCLKA/PO21	RXD5/SMISO5/SSCL5/SSLA3-A/ET0_RX_DV	MMC_CD-A/SDHI_D3-A		
71		P75	CS5#	PO20	SCK11/RTS11/ET0_ERXD0/RMII0_RXD0	MMC_RES#-A/SDHI_D2-A		
72		P74	A20/CS4#	PO19	CTS11#/ET0_ERXD1/RMII0_RXD1			
73		PC1	A17	MTIOC3A/TCLKD/PO18	SCK5/SSLA2-A/ET0_ERXD2		IRQ12	
74	VCC							
75		PC0	A16	MTIOC3C/TCLKC/PO17	CTS5#/RTS5#/SS5#/SSLA1-A/ET0_ERXD3		IRQ14	
76	VSS							
77		P73	CS3#	PO16	ET0_WOL			
78		PB7	A15	MTIOC3B/TIOCB5/PO31	TXD9/ET0_CRS/RMII0_CRS_DV			
79		PB6	A14	MTIOC3D/TIOCA5/PO30	RXD9/ET0_ETXD1/RMII0_TXD1			
80		PB5	A13	MTIOC2A/MTIOC1B/TIOCB4/TMRI1/PO29/POE4#	SCK9/RTS9#/ET0_ETXD0/RMII0_TXD0			
81		PB4	A12	TIOCA4/PO28	CTS9#/ET0_TX_EN/RMII0_TXD_EN			
82		PB3	A11	MTIOC0A/MTIOC4A/TIOCD3/TCLKD/TMO0/PO27/POE11#	SCK4/SCK6/ET0_RX_ER/RMII0_RX_ER			
83		PB2	A10	TIOCC3/TCLKC/PO26	CTS4#/RTS4#/CTS6#/RTS6#/SS4#/SS6#/ET0_RX_CLK/REF50CK0			
84		PB1	A9	MTIOC0C/MTIOC4C/TIOCB3/TMCI0/PO25	TXD4/TXD6/SMOSI4/SMOSI6/SSDA4/SSDA6/ET0_ERXD0/RMII0_RXD0		IRQ4-DS	
85		P72	A19/CS2#		ET0_MDC			
86		P71	A18/CS1#		ET0_MDIO			

Table 1.8 List of Pin and Pin Functions (144-Pin LQFP) (4/5)

Pin Number	Power Supply Clock System Control	I/O Port	Bus EXDMAC SDRAMC	Timer (MTU, GPT, TPU, TMR, PPG, RTC, CMTW, POE, CAC)	Communication (ETHERC, SC1g, SC1h, RSPI, RIIC, CAN, USB, SSI)	Memory Interface Camera Interface (QSPI, SDHI, MMCIF, PDC)	Interrupt	S12ADC, R12DA
87		PB0	A8	MTIC5W/TIOCA3/PO24	RXD4/RXD6/SMISO4/SMISO6/SSCL4/SSCL6/ET0_ERXD1/RMII0_RXD1		IRQ12	
88		PA7	A7	TIOCB2/PO23	MISOA-B/ET0_WOL			
89		PA6	A6	MTIC5V/MTCLKB/GTETR-C/TIOCA2/TMC13/PO22/POE10#	CTS5#/RTS5#/SS5#/MOSIA-B/ET0_EXOUT			
90		PA5	A5	MTIOC6B/TIOCB1/GTIOC0A-C/PO21	RSPCKA-B/ET0_LINKSTA			
91	VCC							
92		PA4	A4	MTIC5U/MTCLKA/TIOCA1/TMRI0/PO20	TXD5/SMOSI5/SSDA5/SSLA0-B/ET0_MDC		IRQ5-DS	
93	VSS							
94		PA3	A3	MTIOC0D/MTCLKD/TIOC0D/TCLKB/PO19	RXD5/SMISO5/SSCL5/ET0_MDIO		IRQ6-DS	
95		PA2	A2	MTIOC7A/GTIOC1A-C/PO18	RXD5/SMISO5/SSCL5/SSLA3-B			
96		PA1	A1	MTIOC0B/MTCLKC/MTIOC7B/GTIOC2A-C/TIOCB0/PO17	SCK5/SSLA2-B/ET0_WOL		IRQ11	
97		PA0	A0/BC0#	MTIOC4A/MTIOC6D/GTIOC0B-C/TIOCA0/CACREF/PO16	SSLA1-B/ET0_TX_EN/RMII0_TXD_EN			
98		P67	CS7#/DQM1	MTIOC7C/GTIOC1B-C	CRX2		IRQ15	
99		P66	CS6#/DQM0	MTIOC7D/GTIOC2B-C	CTX2			
100		P65	CS5#/CKE					
101		PE7	D15[A15/D15]	MTIOC6A/GTIOC3A-E/TOC1	MISOB-B	MMC_RES#-B/SDHI_WP-B	IRQ7	AN105
102		PE6	D14[A14/D14]	MTIOC6C/GTIOC3B-E/TIC1	MOSIB-B	MMC_CD-B/SDHI_CD-B	IRQ6	AN104
103	VCC							
104		P70	SDCLK					
105	VSS							
106		PE5	D13[A13/D13]	MTIOC4C/MTIOC2B/GTIOC0A-A	ET0_RX_CLK/REF50CK0/RSPCKB-B		IRQ5	AN103
107		PE4	D12[A12/D12]	MTIOC4D/MTIOC1A/GTIOC1A-A/PO28	ET0_ERXD2/SSLB0-B			AN102
108		PE3	D11[A11/D11]	MTIOC4B/GTIOC2A-A/PO26/POE8#/TOC3	CTS12#/RTS12#/SS12#/ET0_ERXD3/	MMC_D7-B		AN101
109		PE2	D10[A10/D10]	MTIOC4A/GTIOC0B-A/PO23/TIC3	RXD12/SMISO12/SSCL12/RXD12/SSLB3-B	MMC_D6-B	IRQ7-DS	AN100
110		PE1	D9[A9/D9]	MTIOC4C/MTIOC3B/GTIOC1B-A/PO18	TXD12/SMOSI12/SSDA12/TXDX12/SIOX12/SSLB2-B	MMC_D5-B		ANEX1
111		PE0	D8[A8/D8]	MTIOC3D/GTIOC2B-A	SCK12/SSLB1-B	MMC_D4-B		ANEX0
112		P64	CS4#/WE#					
113		P63	CS3#/CAS#					
114		P62	CS2#/RAS#					
115		P61	CS1#/SDCS#					

Table 1.8 List of Pin and Pin Functions (144-Pin LQFP) (5/5)

Pin Number	Power Supply Clock System Control	I/O Port	Bus EXDMAC SDRAMC	Timer (MTU, GPT, TPU, TMR, PPG, RTC, CMTW, POE, CAC)	Communication (ETHERC, SC1g, SC1h, RSPI, RIIC, CAN, USB, SSI)	Memory Interface Camera Interface (QSPI, SDHI, MMCIF, PDC)	Interrupt	S12ADC, R12DA
116	VSS							
117		P60	CS0#					
118	VCC							
119		PD7	D7[A7/D7]	MTIC5U/POE0#		MMC_D1-B/ SDHI_D1-B/ QIO1-B/QMI-B	IRQ7	AN107
120		PD6	D6[A6/D6]	MTIC5V/MTIOC8A/ POE4#		MMC_D0-B/ SDHI_D0-B/ QIO0-B/QMO- B	IRQ6	AN106
121		PD5	D5[A5/D5]	MTIC5W/MTIOC8C/ POE10#		MMC_CLK-B/ SDHI_CLK-B/ QSPCLK-B	IRQ5	AN113
122		PD4	D4[A4/D4]	MTIOC8B/POE11#		MMC_CMD-B/ SDHI_CMD-B/ QSSL-B	IRQ4	AN112
123		PD3	D3[A3/D3]	MTIOC8D/ GTIOC0A-E/POE8#/ TOC2		MMC_D3-B/ SDHI_D3-B/ QIO3-B	IRQ3	AN111
124		PD2	D2[A2/D2]	MTIOC4D/ GTIOC0B-E/TIC2	CRX0	MMC_D2-B/ SDHI_D2-B/ QIO2-B	IRQ2	AN110
125		PD1	D1[A1/D1]	MTIOC4B/ GTIOC1A-E/POE0#	CTX0		IRQ1	AN109
126		PD0	D0[A0/D0]	GTIOC1B-E/POE4#			IRQ0	AN108
127		P93	A19	POE0#	CTS7#/RTS7#/SS7#			AN117
128		P92	A18	POE4#	RXD7/SMISO7/SSCL7			AN116
129		P91	A17		SCK7			AN115
130	VSS							
131		P90	A16		TXD7/SMOSI7/SSDA7			AN114
132	VCC							
133		P47					IRQ15- DS	AN007
134		P46					IRQ14- DS	AN006
135		P45					IRQ13- DS	AN005
136		P44					IRQ12- DS	AN004
137		P43					IRQ11-DS	AN003
138		P42					IRQ10- DS	AN002
139		P41					IRQ9-DS	AN001
140	VREFL0							
141		P40					IRQ8-DS	AN000
142	VREFH0							
143	AVCC0							
144		P07					IRQ15	ADTRG0#

Note 1. The BCLK function is multiplexed with the I/O port function for pin P53, so the port function is not available if the external bus is enabled.

Table 1.9 List of Pin and Pin Functions (100-Pin TFLGA) (1/4)

Pin Number	Power Supply Clock System Control	I/O Port	Bus EXDMAC	Timer (MTU, GPT, TPU, TMR, PPG, RTC, CMTW, POE, CAC)	Communication (ETHERC, SCIG, SCIH, RSPI, RIIC, CAN, USB, SSI)	Memory Interface Camera Interface (QSPI, SDHI, MMCIF)	Interrupt	S12ADC, R12DA
A1	P05						IRQ13	DA1
A2	AVCC1							
A3		P07					IRQ15	ADTRG0#
A4	VREFL0							
A5		P43					IRQ11-DS	AN003
A6		PD0	D0[A0/D0]	GTIOC1B-E/POE4#			IRQ0	AN108
A7		PD4	D4[A4/D4]	MTIOC8B/POE11#		MMC_CMD-B/ SDHI_CMD-B/ QSSL-B	IRQ4	AN112
A8		PE0	D8[A8/D8]	MTIOC3D/GTIOC2B-A	SCK12/SSLB1-B	MMC_D4-B		ANEX0
A9		PE1	D9[A9/D9]	MTIOC4C/MTIOC3B/ GTIOC1B-A/PO18	TXD12/SMOSI12/ SSDA12/TXD12/ SIOX12/SSLB2-B	MMC_D5-B		ANEX1
A10		PE2	D10[A10/ D10]	MTIOC4A/GTIOC0B- A/PO23/TIC3	RXD12/SMISO12/ SSCL12/RXD12/ SSLB3-B	MMC_D6-B	IRQ7-DS	AN100
B1	EMLE							
B2	AVSS0							
B3	AVCC0							
B4		P40					IRQ8-DS	AN000
B5		P44					IRQ12-DS	AN004
B6		PD1	D1[A1/D1]	MTIOC4B/GTIOC1A- E/POE0#	CTX0		IRQ1	AN109
B7		PD3	D3[A3/D3]	MTIOC8D/GTIOC0A- E/POE8#/TOC2		MMC_D3-B/ SDHI_D3-B/ QIO3-B	IRQ3	AN111
B8		PD6	D6[A6/D6]	MTIC5V/MTIOC8A/ POE4#		MMC_D0-B/ SDHI_D0-B/ QIO0-B/QMO-B	IRQ6	AN106
B9		PD7	D7[A7/D7]	MTIC5U/POE0#		MMC_D1-B/ SDHI_D1-B/ QIO1/QMI-B	IRQ7	AN107
B10		PE3	D11[A11/ D11]	MTIOC4B/GTIOC2A- A/PO26/POE8#/TOC3	CTS12#/RTS12#/ SS12#/ET0_ERXD3	MMC_D7-B		AN101
C1	VCL							
C2	AVSS1							
C3		PJ3	EDACK1	MTIOC3C	ET0_EXOUT/CTS6#/ RTS6#/CTS0#/RTS0#/ SS6#/SS0#			
C4	VREFH0							
C5		P42					IRQ10-DS	AN002
C6		P47					IRQ15-DS	AN007
C7		PD2	D2[A2/D2]	MTIOC4D/GTIOC0B- E/TIC2	CRX0	MMC_D2-B/ SDHI_D2-B/ QIO2-B	IRQ2	AN110
C8		PD5	D5[A5/D5]	MTIC5W/MTIOC8C/ POE10#		MMC_CLK-B/ SDHI_CLK-B/ QSPCLK-B	IRQ5	AN113
C9		PE5	D13[A13/ D13]	MTIOC4C/MTIOC2B/ GTIOC0A-A	ET0_RX_CLK/ REF50CK0/ RSPCKB-B		IRQ5	AN103
C10		PE4	D12[A12/ D12]	MTIOC4D/MTIOC1A/ GTIOC1A-A/PO28	ET0_ERXD2/SSLB0-B			AN102

Table 1.9 List of Pin and Pin Functions (100-Pin TFLGA) (2/4)

Pin Number	Power Supply Clock System Control	I/O Port	Bus EXDMAC	Timer (MTU, GPT, TPU, TMR, PPG, RTC, CMTW, POE, CAC)	Communication (ETHERC, SCIG, SCIH, RSPI, RIIC, CAN, USB, SSI)	Memory Interface Camera Interface (QSPI, SDHI, MMCIF)	Interrupt	S12ADC, R12DA
D1	XCIN							
D2	XCOU							
D3	MD/FINED							
D4	VBATT							
D5		P45					IRQ13-DS	AN005
D6		P46					IRQ14-DS	AN006
D7		PE6	D14[A14/D14]	MTIOC6C/GTIOC3B-E/TIC1	MOSIB-B	MMC_CD-B/SDHI_CD-B	IRQ6	AN104
D8		PE7	D15[A15/D15]	MTIOC6A/GTIOC3A-E/TOC1	MISOB-B	MMC_RES#-B/SDHI_WP-B	IRQ7	AN105
D9		PA1	A1	MTIOC0B/MTCLKC/MTIOC7B/GTIOC2A-C/TIOC0B/PO17	SCK5/SSLA2-B/ET0_WOL		IRQ11	
D10		PA0	A0/BC0#	MTIOC4A/MTIOC6D/GTIOC0B-C/TIOCA0/CACREF/PO16	SSLA1-B/ET0_TX_EN/RMII0_TXD_EN			
E1	XTAL	P37						
E2	VSS							
E3	RES#							
E4	TRST#	P34		MTIOC0A/TMC13/PO12/POE10#	SCK6/SCK0/ET0_LINKSTA		IRQ4	
E5		P41					IRQ9-DS	AN001
E6		PA2	A2	MTIOC7A/GTIOC1A-C/PO18	RXD5/SMISO5/SSCL5/SSLA3-B			
E7		PA6	A6	MTIC5V/MTCLKB/GTETRIG-C/TIOCA2/TMC13/PO22/POE10#	CTS5#/RTS5#/SS5#/MOSIA-B/ET0_EXOUT			
E8		PA4	A4	MTIC5U/MTCLKA/TIOCA1/TMRI0/PO20	TXD5/SMOSI5/SSDA5/SSLA0-B/ET0_MDC		IRQ5-DS	
E9		PA5	A5	MTIOC6B/TIOCB1/GTIOC0A-C/PO21	RSPCKA-B/ET0_LINKSTA			
E10		PA3	A3	MTIOC0D/MTCLKD/TIOC0D/TCLKB/PO19	RXD5/SMISO5/SSCL5/ET0_MDIO		IRQ6-DS	
F1	EXTAL	P36						
F2	VCC							
F3	UPSEL	P35					NMI	
F4		P32		MTIOC0C/TIOCC0/TMO3/PO10/RTCOU/RTCIC2/POE0#/POE10#	TXD6/TXD0/SMOSI6/SMOSI0/SSDA6/SSDA0/CTX0/USB0_VBUSEN		IRQ2-DS	
F5		P12		TMC11	RXD2/SMISO2/SSCL2/SCL0[FM+]		IRQ2	
F6		PB3	A11	MTIOC0A/MTIOC4A/TIOC0D3/TCLKD/TMO0/PO27/POE11#	SCK6/ET0_RX_ER/RMII0_RX_ER			
F7		PB2	A10	TIOCC3/TCLKC/PO26	CTS6#/RTS6#SS6#/ET0_RX_CLK/REF50CK0			
F8		PB0	A8	MTIC5W/TIOCA3/PO24	RXD6/SMISO6/SSCL6/ET0_ERXD1/RMII0_RXD1		IRQ12	
F9		PA7	A7	TIOCB2/PO23	MISOA-B/ET0_WOL			
F10	VSS							

Table 1.9 List of Pin and Pin Functions (100-Pin TFLGA) (3/4)

Pin Number	Power Supply Clock System Control	I/O Port	Bus EXDMAC	Timer (MTU, GPT, TPU, TMR, PPG, RTC, CMTW, POE, CAC)	Communication (ETHERC, SClg, SCiH, RSPI, RIIC, CAN, USB, SSI)	Memory Interface Camera Interface (QSPI, SDHI, MMCIF)	Interrupt	S12ADC, R12DA
G1		P33	EDREQ1	MTIOC0D/TIOC0D/ TMRI3/PO11/POE4#/ POE11#	RXD6/RXD0/SMISO6/ SMISO0/SSCL6/ SSCL0/CRX0		IRQ3-DS	
G2	TMS	P31		MTIOC4D/TMC12/ PO9/RTCIC1	CTS1#/RTS1#/SS1#/ SSLB0-A		IRQ1-DS	
G3	TDI	P30		MTIOC4B/TMRI3/ PO8/RTCIC0/POE8#	RXD1/SMISO1/ SSCL1/MISOB-A		IRQ0-DS	
G4	TCK	P27	CS7#	MTIOC2B/TMC13/PO7	SCK1/RSPCKB-A			
G5		P53*1	BCLK					
G6		P52	RD#		RXD2/SMISO2/ SSCL2/SSLB3-A			
G7		PB5	A13	MTIOC2A/MTIOC1B/ TIOC4/TMRI1/PO29/ POE4#	SCK9/RTS9#/ ET0_ETXD0/ RMII0_TXD0			
G8		PB4	A12	TIOCA4/PO28	CTS9#/ET0_TX_EN/ RMII0_TXD_EN			
G9		PB1	A9	MTIOC0C/MTIOC4C/ TIOC3/TMC10/PO25	TXD6/SMOSI6/ SSDA6/ET0_ERXD0/ RMII0_RXD0		IRQ4-DS	
G10	VCC							
H1	TDO	P26	CS6#	MTIOC2A/TMO1/PO6	TXD1/CTS3#/RTS3#/ SMOSI1/SS3#/ SSDA1/MOSIB-A			
H2		P25	CS5#/ EDACK1	MTIOC4C/MTCLKB/ TIOCA4/PO5	RXD3/SMISO3/ SSCL3/SSIDATA1			ADTRG0#
H3		P16		MTIOC3C/MTIOC3D/ TIOCB1/TCLKC/ TMO2/PO14/ RTCOU	TXD1/RXD3/SMOSI1/ SMISO3/SSDA1/ SSCL3/SCL2-DS/ USB0_VBUS/ USB0_VBUSEN/ USB0_OVRCURB		IRQ6	ADTRG0#
H4		P15		MTIOC0B/MTCLKB/ GTETRQ-B/TIOCB2/ TCLKB/TMC12/PO13	RXD1/SCK3/SMISO1/ SSCL1/CRX1-DS/ SSIWS1		IRQ5	
H5		P55	WAIT#/ EDREQ0	MTIOC4D/TMO3	CRX1/ET0_EXOUT		IRQ10	
H6		P54	ALE/ EDACK0	MTIOC4B/TMC11	CTS2#/RTS2#/SS2#/ CTX1/ET0_LINKSTA			
H7	UB	PC7	A23/CS0#	MTIOC3A/MTCLKB/ GTIOC3A-D/TMO2/ TOC0/PO31/CACREF	TXD8/MISOA-A/ ET0_COL		IRQ14	
H8		PC6	A22/CS1#	MTIOC3C/MTCLKA/ GTIOC3B-D/TMC12/ TIC0/PO30	RXD8/MOSIA-A/ ET0_ETXD3		IRQ13	
H9		PB6	A14	MTIOC3D/TIOCA5/ PO30	RXD9/ET0_ETXD1/ RMII0_TXD1			
H10		PB7	A15	MTIOC3B/TIOCB5/ PO31	TXD9/ET0_CRS/ RMII0_CRS_DV			
J1		P24	CS4#/ EDREQ1	MTIOC4A/MTCLKA/ TIOC4/TMRI1/PO4	SCK3/ USB0_VBUSEN/ SSISCK1			
J2		P21		MTIOC1B/MTIOC4A/ GTIOC2A-B/TIOCA3/ TMC10/PO1	RXD0/SMISO0/ SSCL0/ USB0_EXICEN/ SSIWS0		IRQ9	
J3		P17		MTIOC3A/MTIOC3B/ MTIOC4B/GTIOC0B- B/TIOCB0/TCLKD/ TMO1/PO15/POE8#	SCK1/TXD3/SMOSI3/ SSDA3/SDA2-DS/ SSITXD0		IRQ7	ADTRG1#
J4		P13		MTIOC0B/TIOCA5/ TMO3/PO13	TXD2/SMOSI2/ SSDA2/SDA0[FM+]		IRQ3	ADTRG1#

Table 1.9 List of Pin and Pin Functions (100-Pin TFLGA) (4/4)

Pin Number	Power Supply Clock System Control	I/O Port	Bus EXDMAC	Timer (MTU, GPT, TPU, TMR, PPG, RTC, CMTW, POE, CAC)	Communication (ETHERC, SCIG, SCIH, RSPI, RIIC, CAN, USB, SSI)	Memory Interface Camera Interface (QSPI, SDHI, MMCIF)	Interrupt	S12ADC, R12DA
J5	VSS_USB							
J6	VCC_USB							
J7		P50	WR0#/WR#		TXD2/SMOSI2/SSDA2/SSLB1-A			
J8		PC4	A20/CS3#	MTIOC3D/MTCLKC/GTETR-D/TMCI1/PO25/POE0#	SCK5/CTS8#/SSLA0-A/ET0_TX_CLK			
J9		PC0	A16	MTIOC3C/TCLKC/PO17	CTS5#/RTS5#/SS5#/SSLA1-A/ET0_ERXD3		IRQ14	
J10		PC1	A17	MTIOC3A/TCLKD/PO18	SCK5/SSLA2-A/ET0_ERXD2		IRQ12	
K1		P23	EDACK0	MTIOC3D/MTCLKD/GTIOC0A-B/TIOC3/PO3	TXD3/CTS0#/RTS0#/SMOSI3/SS0#/SSDA3/SSISCK0			
K2		P22	EDREQ0	MTIOC3B/MTCLKC/GTIOC1A-B/TIOCC3/TMO0/PO2	SCK0/USB0_OVRCURB/AUDIO_MCLK			
K3		P20		MTIOC1A/TIOCB3/TMRI0/PO0	TXD0/SMOSI0/SSDA0/USB0_ID/SSIRXD0		IRQ8	
K4		P14		MTIOC3A/MTCLKA/TIOCB5/TCLKA/TMRI2/PO15	CTS1#/RTS1#/SS1#/CTX1/USB0_OVRCURA		IRQ4	
K5					USB0_DM			
K6					USB0_DP			
K7		P51	WR1#/BC1#/WAIT#		SCK2/SSLB2-A			
K8		PC5	A21/CS2#/WAIT#	MTIOC3B/MTCLKD/GTIOC1A-D/TMRI2/PO29	SCK8/RSPCKA-A/RTS8#/ET0_ETXD2			
K9		PC3	A19	MTIOC4D/GTIOC1B-D/TCLKB/PO24	TXD5/SMOSI5/SSDA5/ET0_TX_ER			
K10		PC2	A18	MTIOC4B/GTIOC2B-D/TCLKA/PO21	RXD5/SMISO5/SSCL5/SSLA3-A/ET0_RX_DV			

Note 1. The BCLK function is multiplexed with the I/O port function for pin P53, so the port function is not available if the external bus is enabled.

Table 1.10 List of Pin and Pin Functions (100-Pin LQFP) (1/4)

Pin Number	Power Supply Clock System Control	I/O Port	Bus EXDMAC	Timer (MTU, GPT, TPU, TMR, PPG, RTC, CMTW, POE, CAC)	Communication (ETHERC, SCIG, SCIh, RSPI, RIIC, CAN, USB, SSI)	Memory Interface Camera Interface (QSPI, SDHI, MMCIF)	Interrupt	S12ADC, R12DA
1	AVCC1							
2	EMLE							
3	AVSS1							
4		PJ3	EDACK1	MTIOC3C	ET0_EXOUT CTS6#/RTS6#/CTS0#/ RTS0#/SS6#/SS0#			
5	VCL							
6	VBATT							
7	MD/FINED							
8	XCIN							
9	XCOU							
10	RES#							
11	XTAL	P37						
12	VSS							
13	EXTAL	P36						
14	VCC							
15	UPSEL	P35					NMI	
16	TRST#	P34		MTIOC0A/TMCI3/ PO12/POE10#	SCK6/SCK0/ ET0_LINKSTA		IRQ4	
17		P33	EDREQ1	MTIOC0D/TIOC0D/ TMR13/PO11/POE4#/ POE11#	RXD6/RXD0/SMISO6/ SMISO0/SSCL6/ SSCL0/CRX0		IRQ3-DS	
18		P32		MTIOC0C/TIOCC0/ TMO3/PO10/ RTCOU/RTCIC2/ POE0#/POE10#	TXD6/TXD0/SMOSI6/ SMOSI0/SSDA6/ SSDA0/CTX0/ USB_VBUSEN		IRQ2-DS	
19	TMS	P31		MTIOC4D/TMCI2/ PO9/RTCIC1	CTS1#/RTS1#/SS1#/ SSLB0-A		IRQ1-DS	
20	TDI	P30		MTIOC4B/TMR13/ PO8/RTCIC0/POE8#	RXD1/SMISO1/ SSCL1/MISOB-A		IRQ0-DS	
21	TCK	P27	CS7#	MTIOC2B/TMCI3/PO7	SCK1/RSPCKB-A			
22	TDO	P26	CS6#	MTIOC2A/TMO1/PO6	TXD1/CTS3#/RTS3#/ SMOSI1/SS3#/ SSDA1/MOSIB-A			
23		P25	CS5#/ EDACK1	MTIOC4C/MTCLKB/ TIOCA4/PO5	RXD3/SMISO3/ SSCL3/SSDATA1			ADTRG0#
24		P24	CS4#/ EDREQ1	MTIOC4A/MTCLKA/ TIOCB4/TMR11/PO4	SCK3/ USB_VBUSEN/ SSISCK1			
25		P23	EDACK0	MTIOC3D/MTCLKD/ GTIOC0A-B/TIOC3D/ PO3	TXD3/CTS0#/RTS0#/ SMOSI3/SS0#/ SSDA3/SSISCK0			
26		P22	EDREQ0	MTIOC3B/MTCLKC/ GTIOC1A-B/TIOCC3/ TMO0/PO2	SCK0/ USB_OVRCURB/ AUDIO_MCLK			
27		P21		MTIOC1B/MTIOC4A/ GTIOC2A-B/TIOCA3/ TMCI0/PO1	RXD0/SMISO0/ SSCL0/ USB_EXICEN/ SSIWS0		IRQ9	
28		P20		MTIOC1A/TIOCB3/ TMR10/PO0	TXD0/SMOSI0/ SSDA0/USB_ID/ SSIRXD0		IRQ8	
29		P17		MTIOC3A/MTIOC3B/ MTIOC4B/ GTIOC0B-B/TIOCB0/ TCLKD/TMO1/PO15/ POE8#	SCK1/TXD3/SMOSI3/ SSDA3/SDA2-DS/ SSITXD0		IRQ7	ADTRG1#

Table 1.10 List of Pin and Pin Functions (100-Pin LQFP) (2/4)

Pin Number	Power Supply Clock System Control	I/O Port	Bus EXDMAC	Timer (MTU, GPT, TPU, TMR, PPG, RTC, CMTW, POE, CAC)	Communication (ETHERC, SClg, SClh, RSPI, RIIC, CAN, USB, SSI)	Memory Interface Camera Interface (QSPI, SDHI, MMCIF)	Interrupt	S12ADC, R12DA
30		P16		MTIOC3C/MTIOC3D/ TIOCB1/TCLKC/ TMO2/PO14/ RTCOUT	TXD1/RXD3/SMOSI1/ SMISO3/SSDA1/ SSCL3/SCL2-DS/ USB0_VBUS/ USB0_VBUSEN/ USB0_OVRCURB		IRQ6	ADTRG0#
31		P15		MTIOC0B/MTCLKB/ GTETR-G/TIOCB2/ TCLKB/TMC12/PO13	RXD1/SCK3/SMISO1/ SSCL1/CRX1-DS/ SSIWS1		IRQ5	
32		P14		MTIOC3A/MTCLKA/ TIOCB5/TCLKA/ TMR12/PO15	CTS1#/RTS1#/SS1#/ CTX1/ USB0_OVRCURA		IRQ4	
33		P13		MTIOC0B/TIOCA5/ TMO3/PO13	TXD2/SMOSI2/ SSDA2/SDA0[FM+]		IRQ3	ADTRG1#
34		P12		TMC11	RXD2/SMISO2/ SSCL2/SCL0[FM+]		IRQ2	
35	VCC_USB							
36					USB0_DM			
37					USB0_DP			
38	VSS_USB							
39		P55	WAIT#/ EDREQ0	MTIOC4D/TMO3	CRX1/ET0_EXOUT		IRQ10	
40		P54	ALE/EDACK0	MTIOC4B/TMC11	CTS2#/RTS2#/SS2#/ CTX1/ET0_LINKSTA			
41		P53*1	BCLK					
42		P52	RD#		RXD2/SMISO2/ SSCL2/SSLB3-A			
43		P51	WR1#/BC1#/ WAIT#		SCK2/SSLB2-A			
44		P50	WR0#/WR#		TXD2/SMOSI2/ SSDA2/SSLB1-A			
45	UB	PC7	A23/CS0#	MTIOC3A/MTCLKB/ GTIOC3A-D/TMO2/ TOC0/PO31/CACREF	TXD8/MISOA-A/ ET0_COL		IRQ14	
46		PC6	A22/CS1#	MTIOC3C/MTCLKA/ GTIOC3B-D/TMC12/ TIC0/PO30	RXD8/MOSIA-A/ ET0_ETXD3		IRQ13	
47		PC5	A21/CS2#/ WAIT#	MTIOC3B/MTCLKD/ GTIOC1A-D/TMR12/ PO29	SCK8/RSPCKA-A/ RTS8#/ET0_ETXD2			
48		PC4	A20/CS3#	MTIOC3D/MTCLKC/ GTETR-G/TMC11/ PO25/POE0#	SCK5/CTS8#/ SSLA0-A/ ET0_TX_CLK			
49		PC3	A19	MTIOC4D/ GTIOC1B-D/TCLKB/ PO24	TXD5/SMOSI5/ SSDA5/ET0_TX_ER			
50		PC2	A18	MTIOC4B/ GTIOC2B-D/TCLKA/ PO21	RXD5/SMISO5/ SSCL5/SSLA3-A/ ET0_RX_DV			
51		PC1	A17	MTIOC3A/TCLKD/ PO18	SCK5/SSLA2-A/ ET0_ERXD2		IRQ12	
52		PC0	A16	MTIOC3C/TCLKC/ PO17	CTS5#/RTS5#/SS5#/ SSLA1-A/ET0_ERXD3		IRQ14	
53		PB7	A15	MTIOC3B/TIOCB5/ PO31	TXD9/ET0_CRS/ RMII0_CRS_DV			
54		PB6	A14	MTIOC3D/TIOCA5/ PO30	RXD9/ET0_ETXD1/ RMII0_TXD1			
55		PB5	A13	MTIOC2A/MTIOC1B/ TIOCB4/TMR11/PO29/ POE4#	SCK9/RTS9#/ ET0_ETXD0/ RMII0_TXD0			

Table 1.10 List of Pin and Pin Functions (100-Pin LQFP) (3/4)

Pin Number	Power Supply Clock System Control	I/O Port	Bus EXDMAC	Timer (MTU, GPT, TPU, TMR, PPG, RTC, CMTW, POE, CAC)	Communication (ETHERC, SCIG, SCIH, RSPI, RIIC, CAN, USB, SSI)	Memory Interface Camera Interface (QSPI, SDHI, MMCIF)	Interrupt	S12ADC, R12DA
56		PB4	A12	TIOCA4/PO28	CTS9#/ET0_TX_EN/ RMII0_TXD_EN			
57		PB3	A11	MTIOC0A/MTIOC4A/ TIOC03/TCLKD/ TMO0/PO27/POE11#	SCK6/ET0_RX_ER/ RMII0_RX_ER			
58		PB2	A10	TIOCC3/TCLKC/ PO26	CTS6#/RTS6#SS6#/ ET0_RX_CLK/ REF50CK0			
59		PB1	A9	MTIOC0C/MTIOC4C/ TIOCB3/TMCI0/PO25	TXD6/SMOSI6/ SSDA6/ET0_ERXD0/ RMII0_RXD0		IRQ4-DS	
60	VCC							
61		PB0	A8	MTIC5W/TIOCA3/ PO24	RXD6/SMISO6/ SSCL6/ET0_ERXD1/ RMII0_RXD1		IRQ12	
62	VSS							
63		PA7	A7	TIOCB2/PO23	MISOA-B/ET0_WOL			
64		PA6	A6	MTIC5V/MTCLKB/ GTETRIG-C/TIOCA2/ TMCI3/PO22/POE10#	CTS5#/RTS5#SS5#/ MOSIA-B/ ET0_EXOUT			
65		PA5	A5	MTIOC6B/TIOCB1/ GTIOC0A-C/PO21	RSPCKA-B/ ET0_LINKSTA			
66		PA4	A4	MTIC5U/MTCLKA/ TIOCA1/TMRI0/PO20	TXD5/SMOSI5/ SSDA5/SSLA0-B/ ET0_MDC		IRQ5-DS	
67		PA3	A3	MTIOC0D/MTCLKD/ TIOC00/TCLKB/PO19	RXD5/SMISO5/ SSCL5/ET0_MDIO		IRQ6-DS	
68		PA2	A2	MTIOC7A/ GTIOC1A-C/PO18	RXD5/SMISO5/ SSCL5/SSLA3-B			
69		PA1	A1	MTIOC0B/MTCLKC/ MTIOC7B/ GTIOC2A-C/TIOCB0/ PO17	SCK5/SSLA2-B/ ET0_WOL		IRQ11	
70		PA0	A0/BC0#	MTIOC4A/MTIOC6D/ GTIOC0B-C/TIOCA0/ CACREF/PO16	SSLA1-B/ ET0_TX_EN/ RMII0_TXD_EN			
71		PE7	D15[A15/D15]	MTIOC6A/ GTIOC3A-E/TOC1	MISOB-B	MMC_RES#-B/ SDHI_WP-B	IRQ7	AN105
72		PE6	D14[A14/D14]	MTIOC6C/GTIOC3B- E/TIC1	MOSIB-B	MMC_CD-B/ SDHI_CD-B	IRQ6	AN104
73		PE5	D13[A13/D13]	MTIOC4C/MTIOC2B/ GTIOC0A-A	ET0_RX_CLK/ REF50CK0/ RSPCKB-B		IRQ5	AN103
74		PE4	D12[A12/D12]	MTIOC4D/MTIOC1A/ GTIOC1A-A/PO28	ET0_ERXD2/SSLB0-B			AN102
75		PE3	D11[A11/D11]	MTIOC4B/ GTIOC2A-A/PO26/ POE8#/TOC3	CTS12#/RTS12#/ SS12#/ET0_ERXD3	MMC_D7-B		AN101
76		PE2	D10[A10/D10]	MTIOC4A/ GTIOC0B-A/PO23/ TIC3	RXD12/SMISO12/ SSCL12/RXD12/ SSLB3-B	MMC_D6-B	IRQ7-DS	AN100
77		PE1	D9[A9/D9]	MTIOC4C/MTIOC3B/ GTIOC1B-A/PO18	TXD12/SMOSI12/ SSDA12/TXD12/ SIOX12/SSLB2-B	MMC_D5-B		ANEX1
78		PE0	D8[A8/D8]	MTIOC3D/ GTIOC2B-A	SCK12/SSLB1-B	MMC_D4-B		ANEX0
79		PD7	D7[A7/D7]	MTIC5U/POE0#		MMC_D1-B/ SDHI_D1-B/ QIO1-B/ QMI-B	IRQ7	AN107

Table 1.10 List of Pin and Pin Functions (100-Pin LQFP) (4/4)

Pin Number	Power Supply Clock System Control	I/O Port	Bus EXDMAC	Timer (MTU, GPT, TPU, TMR, PPG, RTC, CMTW, POE, CAC)	Communication (ETHERC, SCIG, SCIH, RSPI, RIIC, CAN, USB, SSI)	Memory Interface Camera Interface (QSPI, SDHI, MMCIF)	Interrupt	S12ADC, R12DA
80		PD6	D6[A6/D6]	MTIC5V/MTIOC8A/POE4#		MMC_D0-B/ SDHI_D0-B/ QIO0-B/QMO-B	IRQ6	AN106
81		PD5	D5[A5/D5]	MTIC5W/MTIOC8C/POE10#		MMC_CLK-B/ SDHI_CLK-B/ QSPCLK-B	IRQ5	AN113
82		PD4	D4[A4/D4]	MTIOC8B/POE11#		MMC_CMD-B/ SDHI_CMD-B/ QSSL-B	IRQ4	AN112
83		PD3	D3[A3/D3]	MTIOC8D/ GTIOC0A-E/POE8#/ TOC2		MMC_D3-B/ SDHI_D3-B/ QIO3-B	IRQ3	AN111
84		PD2	D2[A2/D2]	MTIOC4D/ GTIOC0B-E/TIC2	CRX0	MMC_D2-B/ SDHI_D2-B/ QIO2-B	IRQ2	AN110
85		PD1	D1[A1/D1]	MTIOC4B/ GTIOC1A-E/POE0#	CTX0		IRQ1	AN109
86		PD0	D0[A0/D0]	GTIOC1B-E/POE4#			IRQ0	AN108
87		P47					IRQ15-DS	AN007
88		P46					IRQ14-DS	AN006
89		P45					IRQ13-DS	AN005
90		P44					IRQ12-DS	AN004
91		P43					IRQ11-DS	AN003
92		P42					IRQ10-DS	AN002
93		P41					IRQ9-DS	AN001
94	VREFL0							
95		P40					IRQ8-DS	AN000
96	VREFH0							
97	AVCC0							
98		P07					IRQ15	ADTRG0#
99	AVSS0							
100	P05						IRQ13	DA1

Note 1. The BCLK function is multiplexed with the I/O port function for pin P53, so the port function is not available if the external bus is enabled.

2. CPU

Figure 2.1 shows register set of the CPU.



Figure 2.1 Register Set of the CPU

2.1 General-Purpose Registers (R0 to R15)

This CPU has sixteen 32-bit general-purpose registers (R0 to R15). R0 to R15 can be used as data registers or address registers.

R0, a general-purpose register, also functions as the stack pointer (SP).

The stack pointer is switched to operate as the interrupt stack pointer (ISP) or user stack pointer (USP) by the value of the stack pointer select bit (U) in the processor status word (PSW).

2.2 Control Registers

(1) Interrupt Stack Pointer (ISP) / User Stack Pointer (USP)

The stack pointer (SP) can be either of two types, the interrupt stack pointer (ISP) or the user stack pointer (USP). Whether the stack pointer operates as the ISP or USP depends on the value of the stack pointer select bit (U) in the processor status word (PSW).

(2) Exception Table Register (EXTB)

The exception table register (EXTB) specifies the address where the exception vector table starts.

(3) Interrupt Table Register (INTB)

The interrupt table register (INTB) specifies the address where the interrupt vector table starts.

(4) Program Counter (PC)

The program counter (PC) indicates the address of the instruction being executed.

(5) Processor Status Word (PSW)

The processor status word (PSW) indicates the results of instruction execution or the state of the CPU.

(6) Backup PC (BPC)

The backup PC (BPC) is provided to speed up response to interrupts.

After a fast interrupt has been generated, the contents of the program counter (PC) are saved in the BPC register.

(7) Backup PSW (BPSW)

The backup PSW (BPSW) is provided to speed up response to interrupts.

After a fast interrupt has been generated, the contents of the processor status word (PSW) are saved in the BPSW. The allocation of bits in the BPSW corresponds to that in the PSW.

(8) Fast Interrupt Vector Register (FINTV)

The fast interrupt vector register (FINTV) is provided to speed up response to interrupts.

The FINTV register specifies a branch destination address when a fast interrupt has been generated.

(9) Floating-Point Status Word (FPSW)

The floating-point status word (FPSW) indicates the results of floating-point operations.

When an exception handling enable bit (E_j) enables the exception handling ($E_j = 1$), the exception cause can be identified by checking the corresponding C_j flag in the exception handling routine. If the exception handling is masked ($E_j = 0$), the occurrence of exception can be checked by reading the F_j flag at the end of a series of processing. Once the F_j flag has been set to 1, this value is retained until it is cleared to 0 by software ($j = X, U, Z, O, \text{ or } V$).

2.3 Accumulator

The accumulator (ACC0 or ACC1) is a 72-bit register used for DSP instructions. The accumulator is handled as a 96-bit register for reading and writing. At this time, when bits 95 to 72 of the accumulator are read, the value where the value of bit 71 is sign extended is read. Writing to bits 95 to 72 of the accumulator is ignored. ACC0 is also used for the multiply and multiply-and-accumulate instructions; EMUL, EMULU, FMUL, MUL, and RMPA, in which case the prior value in ACC0 is modified by execution of the instruction.

Use the MVTACGU, MVTACHI, and MVTACLO instructions for writing to the accumulator. The MVTACGU, MVTACHI, and MVTACLO instructions write data to bits 95 to 64, the higher-order 32 bits (bits 63 to 32), and the lower-order 32 bits (bits 31 to 0), respectively.

Use the MVFACGU, MVFACHI, MVFACMI, and MVFACLO instructions for reading data from the accumulator. The MVFACGU, MVFACHI, MVFACMI, and MVFACLO instructions read data from the guard bits (bits 95 to 64), higher-order 32 bits (bits 63 to 32), the middle 32 bits (bits 47 to 16), and the lower-order 32 bits (bits 31 to 0), respectively.

3. Address Space

3.1 Address Space

This MCU has a 4-Gbyte address space, consisting of the range of addresses from 0000 0000h to FFFF FFFFh. That is, linear access to an address space of up to 4 Gbytes is possible, and this contains both program and data areas.

Figure 3.1 shows the memory maps in the respective operating modes. Accessible areas will differ according to the operating mode and states of control bits.

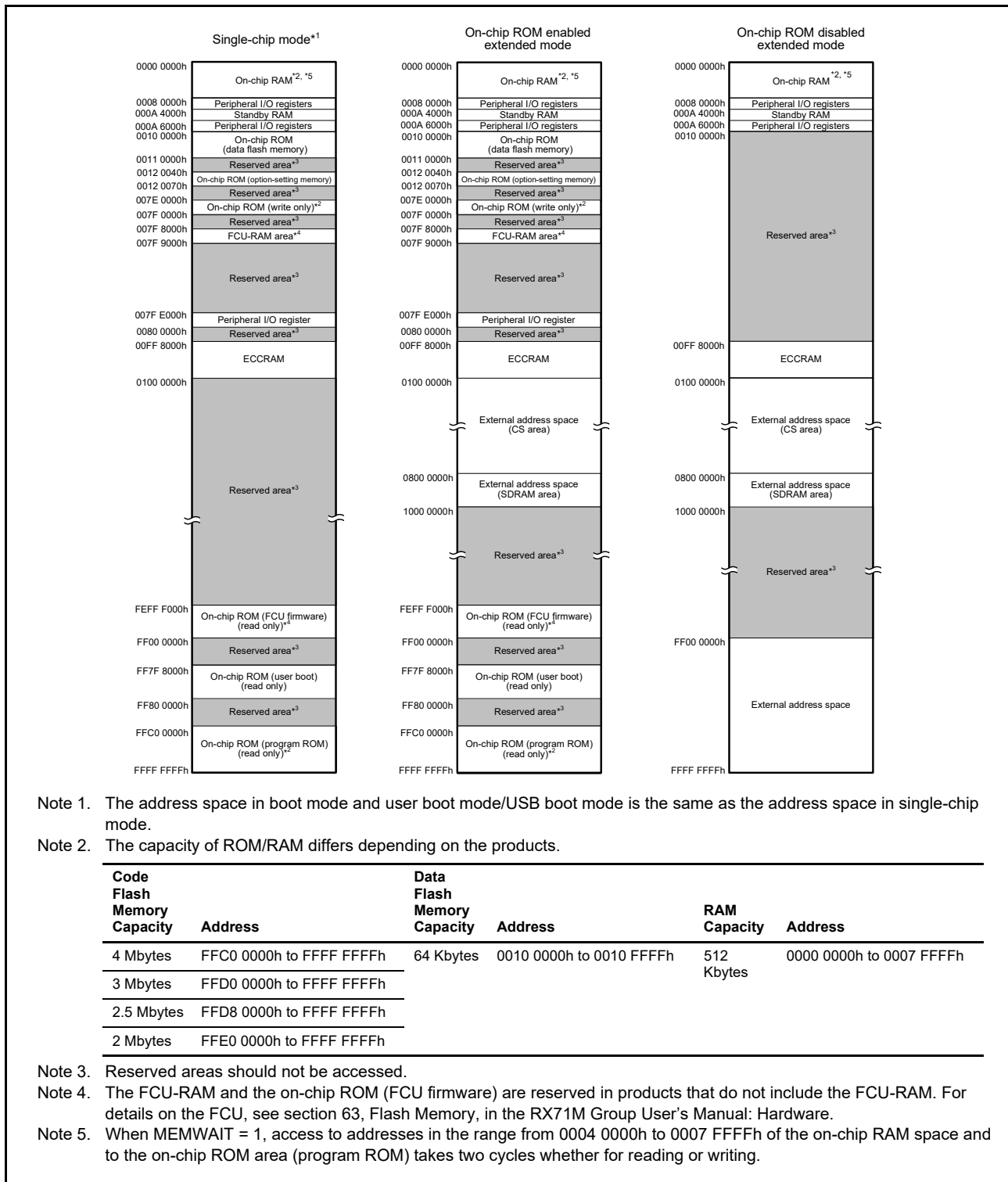

Figure 3.1 Memory Map in Each Operating Mode

3.2 External Address Space

The external address space is divided into CS areas (CS0 to CS7) and SDRAM area (SDCS). The CS areas are divided into up to eight areas (CS0 to CS7), each corresponding to the CSn# signal output from a CSn# (n = 0 to 7) pin.

Figure 3.2 shows the address ranges corresponding to the individual CS areas (CS0 to CS7) and SDRAM areas (SDCS) in on-chip ROM disabled extended mode.



Figure 3.2 Correspondence between External Address Spaces and CS Areas (In On-Chip ROM Disabled Extended Mode)

4. I/O Registers

This section gives information on the on-chip I/O register addresses. The information is given as shown below. Notes on writing to registers are also given at the end.

(1) I/O register addresses (address order)

- Registers are listed from the lower allocation addresses.
- Registers are classified according to module symbols.
- The number of access cycles indicates the number of cycles based on the specified reference clock.
- Among the internal I/O register area, addresses not listed in the list of registers are reserved. Reserved addresses must not be accessed. Do not access these addresses; otherwise, the operation when accessing these bits and subsequent operations cannot be guaranteed.

(2) Notes on writing to I/O registers

When writing to an I/O register, the CPU starts executing the subsequent instruction before completing I/O register write. This may cause the subsequent instruction to be executed before the post-update I/O register value is reflected on the operation.

As described in the following examples, special care is required for the cases in which the subsequent instruction must be executed after the post-update I/O register value is actually reflected.

[Examples of cases requiring special care]

- The subsequent instruction must be executed while an interrupt request is disabled with the IENj bit in IERN of the ICU (interrupt request enable bit) set to 0.
- A WAIT instruction is executed immediately after the preprocessing for causing a transition to the low power consumption state.

In the above cases, after writing to an I/O register, wait until the write operation is completed using the following procedure and then execute the subsequent instruction.

- Write to an I/O register.
- Read the value from the I/O register to a general register.
- Execute the operation using the value read.
- Execute the subsequent instruction.

[Instruction examples]

- Byte-size I/O registers

```
MOV.L #SFR_ADDR, R1
MOV.B #SFR_DATA, [R1]
CMP [R1].UB, R1
;; Next process
```

- Word-size I/O registers

```
MOV.L #SFR_ADDR, R1
MOV.W #SFR_DATA, [R1]
CMP [R1].W, R1
;; Next process
```

- Longword-size I/O registers

```
MOV.L #SFR_ADDR, R1
MOV.L #SFR_DATA, [R1]
CMP [R1].L, R1
;; Next process
```

If multiple registers are written to and a subsequent instruction should be executed after the write operations are entirely completed, only read the I/O register that was last written to and execute the operation using the value; it is not necessary to read or execute operation for all the registers that were written to.

(3) Number of Access Cycles to I/O Registers

For the number of I/O register access cycles, refer to Table 4.1, List of I/O Registers (Address Order).

The number of access cycles to I/O registers is obtained by following equation.*1

Number of access cycles to I/O registers = Number of bus cycles for internal main bus 1 +
 Number of divided clock synchronization cycles +
 Number of bus cycles for internal peripheral busses 1 to 6

The number of bus cycles of internal peripheral bus 1 to 6 differs according to the register to be accessed. When peripheral functions connected to internal peripheral bus 2 to 6 or registers for the external bus control unit (except for bus error related registers) are accessed, the number of divided clock synchronization cycles is added.

The number of divided clock synchronization cycles differs depending on the frequency ratio between ICLK and PCLK (or FCLK, BCLK) or bus access timing.

In the peripheral function unit, when the frequency ratio of ICLK is equal to or greater than that of PCLK (or FCLK), the sum of the number of bus cycles for internal main bus 1 and the number of the divided clock synchronization cycles will be one cycle of PCLK (or FCLK) at a maximum. Therefore, one PCLK (or FCLK) has been added to the number of access states shown in Table 4.1.

When the frequency ratio of ICLK is lower than that of PCLK (or FCLK), the subsequent bus access is started from the ICLK cycle following the completion of the access to the peripheral functions. Therefore, the access cycles are described on an ICLK basis.

In the external bus control unit, the sum of the number of bus cycles for internal main bus 1 and the number of divided clock synchronization cycles will be one cycle of BCLK at a maximum. Therefore, one BCLK is added to the number of access cycles shown in Table 4.1.

Note 1. This applies to the number of cycles when the access from the CPU does not conflict with the instruction fetching to the external memory or bus access from the different bus master (DMAC or DTC).

(4) Notes on Sleep Mode and Mode Transitions

During sleep mode or mode transitions, do not write to the registers related to system control (indicated by 'SYSTEM' in the Module Symbol column in Table 4.1, List of I/O Registers (Address Order)).

(5) Restrictions in Relation to RMPA and String-Manipulation Instructions

The allocation of data to be handled by RMPA or string-manipulation instructions to I/O registers is prohibited, and operation is not guaranteed if this restriction is not observed.

4.1 I/O Register Addresses (Address Order)

Table 4.1 List of I/O Registers (Address Order) (1 / 70)

Address	Module Symbol	Register Name	Register Symbol	Number of Bits	Access Size	Number of Access Cycles		Related Function
						ICLK ≥ PCLK	ICLK < PCLK	
0008 0000h	SYSTEM	Mode Monitor Register	MDMONR	16	16	3 ICLK		Operating Modes
0008 0002h	SYSTEM	Mode Status Register	MDSR	16	16	3 ICLK		Operating Modes
0008 0006h	SYSTEM	System Control Register 0	SYSCR0	16	16	3 ICLK		Operating Modes
0008 0008h	SYSTEM	System Control Register 1	SYSCR1	16	16	3 ICLK		Operating Modes
0008 000Ch	SYSTEM	Standby Control Register	SBYCR	16	16	3 ICLK		Low Power Consumption
0008 0010h	SYSTEM	Module Stop Control Register A	MSTPCRA	32	32	3 ICLK		Low Power Consumption
0008 0014h	SYSTEM	Module Stop Control Register B	MSTPCRB	32	32	3 ICLK		Low Power Consumption
0008 0018h	SYSTEM	Module Stop Control Register C	MSTPCRC	32	32	3 ICLK		Low Power Consumption
0008 001Ch	SYSTEM	Module Stop Control Register D	MSTPCRD	32	32	3 ICLK		Low Power Consumption
0008 0020h	SYSTEM	System Clock Control Register	SCKCR	32	32	3 ICLK		Clock Generation Circuit
0008 0024h	SYSTEM	System Clock Control Register 2	SCKCR2	16	16	3 ICLK		Clock Generation Circuit
0008 0026h	SYSTEM	System Clock Control Register 3	SCKCR3	16	16	3 ICLK		Clock Generation Circuit
0008 0028h	SYSTEM	PLL Control Register	PLLCR	16	16	3 ICLK		Clock Generation Circuit
0008 002Ah	SYSTEM	PLL Control Register 2	PLLCR2	8	8	3 ICLK		Clock Generation Circuit
0008 0030h	SYSTEM	External Bus Clock Control Register	BCKCR	8	8	3 ICLK		Clock Generation Circuit
0008 0032h	SYSTEM	Main Clock Oscillator Control Register	MOSCCR	8	8	3 ICLK		Clock Generation Circuit
0008 0033h	SYSTEM	Sub-Clock Oscillator Control Register	SOSCCR	8	8	3 ICLK		Clock Generation Circuit
0008 0034h	SYSTEM	Low-Speed On-Chip Oscillator Control Register	LOCOCR	8	8	3 ICLK		Clock Generation Circuit

Table 4.1 List of I/O Registers (Address Order) (2 / 70)

Address	Module Symbol	Register Name	Register Symbol	Number of Bits	Access Size	Number of Access Cycles		Related Function
						ICLK ≥ PCLK	ICLK < PCLK	
0008 0035h	SYSTEM	IWDT-Dedicated On-Chip Oscillator Control Register	ILOCOCR	8	8	3 ICLK		Clock Generation Circuit
0008 0036h	SYSTEM	High-Speed On-Chip Oscillator Control Register	HOCOCR	8	8	3 ICLK		Clock Generation Circuit
0008 0037h	SYSTEM	High-Speed On-Chip Oscillator Control Register 2	HOCOCR2	8	8	3 ICLK		Clock Generation Circuit
0008 003Ch	SYSTEM	Oscillation Stabilization Flag Register	OSCOVFSR	8	8	3 ICLK		Clock Generation Circuit
0008 0040h	SYSTEM	Oscillation Stop Detection Control Register	OSTDCR	8	8	3 ICLK		Clock Generation Circuit
0008 0041h	SYSTEM	Oscillation Stop Detection Status Register	OSTDSR	8	8	3 ICLK		Clock Generation Circuit
0008 00A0h	SYSTEM	Operating Power Control Register	OPCCR	8	8	3 ICLK		Low Power Consumption
0008 00A1h	SYSTEM	Sleep Mode Return Clock Source Switching Register	RSTCKCR	8	8	3 ICLK		Low Power Consumption
0008 00A2h	SYSTEM	Main Clock Oscillator Wait Control Register	MOSCWTCR	8	8	3 ICLK		Clock Generation Circuit
0008 00A3h	SYSTEM	Sub-Clock Oscillator Wait Control Register	SOSCWTCR	8	8	3 ICLK		Clock Generation Circuit
0008 00C0h	SYSTEM	Reset Status Register 2	RSTSR2	8	8	3 ICLK		Resets
0008 00C2h	SYSTEM	Software Reset Register	SWRR	16	16	3 ICLK		Resets
0008 00E0h	SYSTEM	Voltage Monitoring 1 Circuit Control Register 1	LVD1CR1	8	8	3 ICLK		LVDA
0008 00E1h	SYSTEM	Voltage Monitoring 1 Circuit Status Register	LVD1SR	8	8	3 ICLK		LVDA
0008 00E2h	SYSTEM	Voltage Monitoring 2 Circuit Control Register 1	LVD2CR1	8	8	3 ICLK		LVDA
0008 00E3h	SYSTEM	Voltage Monitoring 2 Circuit Status Register	LVD2SR	8	8	3 ICLK		LVDA
0008 03FEh	SYSTEM	Protect Register	PRCR	16	16	3 ICLK		Register Write Protection Function
0008 1200h	RAM	RAM Operating Mode Control Register	RAMMODE	8	8	2 ICLK		RAM
0008 1201h	RAM	RAM Error Status Register	RAMSTS	8	8	2 ICLK		RAM
0008 1204h	RAM	RAM Protection Register	RAMPRCR	8	8	2 ICLK		RAM
0008 1208h	RAM	RAM Error Address Capture Register	RAMECAD	32	32	2 ICLK		RAM
0008 12C0h	ECCRAM	ECCRAM Operating Mode Control Register	ECCRAMMODE	8	8	2 ICLK		RAM
0008 12C1h	ECCRAM	ECCRAM 2-Bit Error Status Register	ECCRAM2STS	8	8	2 ICLK		RAM
0008 12C2h	ECCRAM	ECCRAM 1-Bit Error Information Update Enable Register	ECCRAM1STSEN	8	8	2 ICLK		RAM

Table 4.1 List of I/O Registers (Address Order) (3 / 70)

Address	Module Symbol	Register Name	Register Symbol	Number of Bits	Access Size	Number of Access Cycles		Related Function
						ICLK ≥ PCLK	ICLK < PCLK	
0008 12C3h	ECCRAM	ECCRAM 1-Bit Error Status Register	ECCRAM1STS	8	8	2 ICLK		RAM
0008 12C4h	ECCRAM	ECCRAM Protection Register	ECCRAMPCR	8	8	2 ICLK		RAM
0008 12C8h	ECCRAM	ECCRAM 2-Bit Error Address Capture Register	ECCRAM2ECAD	32	32	2 ICLK		RAM
0008 12CCh	ECCRAM	ECCRAM 1-Bit Error Address Capture Register	ECCRAM1ECAD	32	32	2 ICLK		RAM
0008 12D0h	ECCRAM	ECCRAM Protection Register 2	ECCRAMPCR2	8	8	2 ICLK		RAM
0008 12D4h	ECCRAM	ECCRAM Test Control Register	ECCRAMETS	8	8	2 ICLK		RAM
0008 1300h	BSC	Bus Error Status Clear Register	BERCLR	8	8	2 ICLK		Buses
0008 1304h	BSC	Bus Error Monitoring Enable Register	BEREN	8	8	2 ICLK		Buses
0008 1308h	BSC	Bus Error Status Register 1	BERSR1	8	8	2 ICLK		Buses
0008 130Ah	BSC	Bus Error Status Register 2	BERSR2	16	16	2 ICLK		Buses
0008 1310h	BSC	Bus Priority Control Register	BUSPRI	16	16	2 ICLK		Buses
0008 2000h	DMAC0	DMA Source Address Register	DMSAR	32	32	2 ICLK		DMACa
0008 2004h	DMAC0	DMA Destination Address Register	DMDAR	32	32	2 ICLK		DMACa
0008 2008h	DMAC0	DMA Transfer Count Register	DMCRA	32	32	2 ICLK		DMACa
0008 200Ch	DMAC0	DMA Block Transfer Count Register	DMCRB	16	16	2 ICLK		DMACa
0008 2010h	DMAC0	DMA Transfer Mode Register	DMTMD	16	16	2 ICLK		DMACa
0008 2013h	DMAC0	DMA Interrupt Setting Register	DMINT	8	8	2 ICLK		DMACa
0008 2014h	DMAC0	DMA Address Mode Register	DMAMD	16	16	2 ICLK		DMACa
0008 2018h	DMAC0	DMA Offset Register	DMOFR	32	32	2 ICLK		DMACa
0008 201Ch	DMAC0	DMA Transfer Enable Register	DMCNT	8	8	2 ICLK		DMACa
0008 201Dh	DMAC0	DMA Software Start Register	DMREQ	8	8	2 ICLK		DMACa
0008 201Eh	DMAC0	DMA Status Register	DMSTS	8	8	2 ICLK		DMACa
0008 201Fh	DMAC0	DMA Request Source Flag Control Register	DMCSL	8	8	2 ICLK		DMACa
0008 2040h	DMAC1	DMA Source Address Register	DMSAR	32	32	2 ICLK		DMACa
0008 2044h	DMAC1	DMA Destination Address Register	DMDAR	32	32	2 ICLK		DMACa
0008 2048h	DMAC1	DMA Transfer Count Register	DMCRA	32	32	2 ICLK		DMACa
0008 204Ch	DMAC1	DMA Block Transfer Count Register	DMCRB	16	16	2 ICLK		DMACa
0008 2050h	DMAC1	DMA Transfer Mode Register	DMTMD	16	16	2 ICLK		DMACa
0008 2053h	DMAC1	DMA Interrupt Setting Register	DMINT	8	8	2 ICLK		DMACa
0008 2054h	DMAC1	DMA Address Mode Register	DMAMD	16	16	2 ICLK		DMACa
0008 205Ch	DMAC1	DMA Transfer Enable Register	DMCNT	8	8	2 ICLK		DMACa
0008 205Dh	DMAC1	DMA Software Start Register	DMREQ	8	8	2 ICLK		DMACa
0008 205Eh	DMAC1	DMA Status Register	DMSTS	8	8	2 ICLK		DMACa
0008 205Fh	DMAC1	DMA Request Source Flag Control Register	DMCSL	8	8	2 ICLK		DMACa
0008 2080h	DMAC2	DMA Source Address Register	DMSAR	32	32	2 ICLK		DMACa
0008 2084h	DMAC2	DMA Destination Address Register	DMDAR	32	32	2 ICLK		DMACa
0008 2088h	DMAC2	DMA Transfer Count Register	DMCRA	32	32	2 ICLK		DMACa
0008 208Ch	DMAC2	DMA Block Transfer Count Register	DMCRB	16	16	2 ICLK		DMACa
0008 2090h	DMAC2	DMA Transfer Mode Register	DMTMD	16	16	2 ICLK		DMACa
0008 2093h	DMAC2	DMA Interrupt Setting Register	DMINT	8	8	2 ICLK		DMACa
0008 2094h	DMAC2	DMA Address Mode Register	DMAMD	16	16	2 ICLK		DMACa
0008 209Ch	DMAC2	DMA Transfer Enable Register	DMCNT	8	8	2 ICLK		DMACa
0008 209Dh	DMAC2	DMA Software Start Register	DMREQ	8	8	2 ICLK		DMACa
0008 209Eh	DMAC2	DMA Status Register	DMSTS	8	8	2 ICLK		DMACa
0008 209Fh	DMAC2	DMA Request Source Flag Control Register	DMCSL	8	8	2 ICLK		DMACa
0008 20C0h	DMAC3	DMA Source Address Register	DMSAR	32	32	2 ICLK		DMACa

Table 4.1 List of I/O Registers (Address Order) (4 / 70)

Address	Module Symbol	Register Name	Register Symbol	Number of Bits	Access Size	Number of Access Cycles		Related Function
						ICLK ≥ PCLK	ICLK < PCLK	
0008 20C4h	DMAC3	DMA Destination Address Register	DMDAR	32	32		2 ICLK	DMACAA
0008 20C8h	DMAC3	DMA Transfer Count Register	DMCRA	32	32		2 ICLK	DMACAA
0008 20CCh	DMAC3	DMA Block Transfer Count Register	DMCRB	16	16		2 ICLK	DMACAA
0008 20D0h	DMAC3	DMA Transfer Mode Register	DMTMD	16	16		2 ICLK	DMACAA
0008 20D3h	DMAC3	DMA Interrupt Setting Register	DMINT	8	8		2 ICLK	DMACAA
0008 20D4h	DMAC3	DMA Address Mode Register	DMAMD	16	16		2 ICLK	DMACAA
0008 20DCh	DMAC3	DMA Transfer Enable Register	DMCNT	8	8		2 ICLK	DMACAA
0008 20DDh	DMAC3	DMA Software Start Register	DMREQ	8	8		2 ICLK	DMACAA
0008 20DEh	DMAC3	DMA Status Register	DMSTS	8	8		2 ICLK	DMACAA
0008 20DFh	DMAC3	DMA Request Source Flag Control Register	DMCSL	8	8		2 ICLK	DMACAA
0008 2100h	DMAC4	DMA Source Address Register	DMSAR	32	32		2 ICLK	DMACAA
0008 2104h	DMAC4	DMA Destination Address Register	DMDAR	32	32		2 ICLK	DMACAA
0008 2108h	DMAC4	DMA Transfer Count Register	DMCRA	32	32		2 ICLK	DMACAA
0008 210Ch	DMAC4	DMA Block Transfer Count Register	DMCRB	16	16		2 ICLK	DMACAA
0008 2110h	DMAC4	DMA Transfer Mode Register	DMTMD	16	16		2 ICLK	DMACAA
0008 2113h	DMAC4	DMA Interrupt Setting Register	DMINT	8	8		2 ICLK	DMACAA
0008 2114h	DMAC4	DMA Address Mode Register	DMAMD	16	16		2 ICLK	DMACAA
0008 211Ch	DMAC4	DMA Transfer Enable Register	DMCNT	8	8		2 ICLK	DMACAA
0008 211Dh	DMAC4	DMA Software Start Register	DMREQ	8	8		2 ICLK	DMACAA
0008 211Eh	DMAC4	DMA Status Register	DMSTS	8	8		2 ICLK	DMACAA
0008 211Fh	DMAC4	DMA Request Source Flag Control Register	DMCSL	8	8		2 ICLK	DMACAA
0008 2140h	DMAC5	DMA Source Address Register	DMSAR	32	32		2 ICLK	DMACAA
0008 2144h	DMAC5	DMA Destination Address Register	DMDAR	32	32		2 ICLK	DMACAA
0008 2148h	DMAC5	DMA Transfer Count Register	DMCRA	32	32		2 ICLK	DMACAA
0008 214Ch	DMAC5	DMA Block Transfer Count Register	DMCRB	16	16		2 ICLK	DMACAA
0008 2150h	DMAC5	DMA Transfer Mode Register	DMTMD	16	16		2 ICLK	DMACAA
0008 2153h	DMAC5	DMA Interrupt Setting Register	DMINT	8	8		2 ICLK	DMACAA
0008 2154h	DMAC5	DMA Address Mode Register	DMAMD	16	16		2 ICLK	DMACAA
0008 215Ch	DMAC5	DMA Transfer Enable Register	DMCNT	8	8		2 ICLK	DMACAA
0008 215Dh	DMAC5	DMA Software Start Register	DMREQ	8	8		2 ICLK	DMACAA
0008 215Eh	DMAC5	DMA Status Register	DMSTS	8	8		2 ICLK	DMACAA
0008 215Fh	DMAC5	DMA Request Source Flag Control Register	DMCSL	8	8		2 ICLK	DMACAA
0008 2180h	DMAC6	DMA Source Address Register	DMSAR	32	32		2 ICLK	DMACAA
0008 2184h	DMAC6	DMA Destination Address Register	DMDAR	32	32		2 ICLK	DMACAA
0008 2188h	DMAC6	DMA Transfer Count Register	DMCRA	32	32		2 ICLK	DMACAA
0008 218Ch	DMAC6	DMA Block Transfer Count Register	DMCRB	16	16		2 ICLK	DMACAA
0008 2190h	DMAC6	DMA Transfer Mode Register	DMTMD	16	16		2 ICLK	DMACAA
0008 2193h	DMAC6	DMA Interrupt Setting Register	DMINT	8	8		2 ICLK	DMACAA
0008 2194h	DMAC6	DMA Address Mode Register	DMAMD	16	16		2 ICLK	DMACAA
0008 219Ch	DMAC6	DMA Transfer Enable Register	DMCNT	8	8		2 ICLK	DMACAA
0008 219Dh	DMAC6	DMA Software Start Register	DMREQ	8	8		2 ICLK	DMACAA
0008 219Eh	DMAC6	DMA Status Register	DMSTS	8	8		2 ICLK	DMACAA
0008 219Fh	DMAC6	DMA Request Source Flag Control Register	DMCSL	8	8		2 ICLK	DMACAA
0008 21C0h	DMAC7	DMA Source Address Register	DMSAR	32	32		2 ICLK	DMACAA
0008 21C4h	DMAC7	DMA Destination Address Register	DMDAR	32	32		2 ICLK	DMACAA
0008 21C8h	DMAC7	DMA Transfer Count Register	DMCRA	32	32		2 ICLK	DMACAA
0008 21CCh	DMAC7	DMA Block Transfer Count Register	DMCRB	16	16		2 ICLK	DMACAA
0008 21D0h	DMAC7	DMA Transfer Mode Register	DMTMD	16	16		2 ICLK	DMACAA
0008 21D3h	DMAC7	DMA Interrupt Setting Register	DMINT	8	8		2 ICLK	DMACAA
0008 21D4h	DMAC7	DMA Address Mode Register	DMAMD	16	16		2 ICLK	DMACAA

Table 4.1 List of I/O Registers (Address Order) (5 / 70)

Address	Module Symbol	Register Name	Register Symbol	Number of Bits	Access Size	Number of Access Cycles		Related Function
						ICLK ≥ PCLK	ICLK < PCLK	
0008 21DCh	DMAC7	DMA Transfer Enable Register	DMCNT	8	8	2 ICLK		DMACAa
0008 21DDh	DMAC7	DMA Software Start Register	DMREQ	8	8	2 ICLK		DMACAa
0008 21DEh	DMAC7	DMA Status Register	DMSTS	8	8	2 ICLK		DMACAa
0008 21DFh	DMAC7	DMA Request Source Flag Control Register	DMCSL	8	8	2 ICLK		DMACAa
0008 2200h	DMAC	DMAC Module Start Register	DMAST	8	8	2 ICLK		DMACAa
0008 2204h	DMAC	DMAC74 Interrupt Status Monitor Register	DMIST	8	8	2 ICLK		DMACAa
0008 2400h	DTC	DTC Control Register	DTCCR	8	8	2 ICLK		DTCa
0008 2404h	DTC	DTC Vector Base Register	DTCVBR	32	32	2 ICLK		DTCa
0008 2408h	DTC	DTC Address Mode Register	DTCADMOD	8	8	2 ICLK		DTCa
0008 240Ch	DTC	DTC Module Start Register	DTCST	8	8	2 ICLK		DTCa
0008 240Eh	DTC	DTC Status Register	DTCSTS	16	16	2 ICLK		DTCa
0008 2800h	EXDMA C0	EXDMA Source Address Register	EDMSAR	32	32	1, 2 BCLK		EXDMA Ca
0008 2804h	EXDMA C0	EXDMA Destination Address Register	EDMDAR	32	32	1, 2 BCLK		EXDMA Ca
0008 2808h	EXDMA C0	EXDMA Transfer Count Register	EDMCRA	32	32	1, 2 BCLK		EXDMA Ca
0008 280Ch	EXDMA C0	EXDMA Block Transfer Count Register	EDMCRB	16	16	1, 2 BCLK		EXDMA Ca
0008 2810h	EXDMA C0	EXDMA Transfer Mode Register	EDMTMD	16	16	1, 2 BCLK		EXDMA Ca
0008 2812h	EXDMA C0	EXDMA Output Setting Register	EDMOMD	8	8	1, 2 BCLK		EXDMA Ca
0008 2813h	EXDMA C0	EXDMA Interrupt Setting Register	EDMINT	8	8	1, 2 BCLK		EXDMA Ca
0008 2814h	EXDMA C0	EXDMA Address Mode Register	EDMAMD	32	32	1, 2 BCLK		EXDMA Ca
0008 2818h	EXDMA C0	EXDMA Offset Register	EDMOFR	32	32	1, 2 BCLK		EXDMA Ca
0008 281Ch	EXDMA C0	EXDMA Transfer Enable Register	EDMCNT	8	8	1, 2 BCLK		EXDMA Ca
0008 281Dh	EXDMA C0	EXDMA Software Start Register	EDMREQ	8	8	1, 2 BCLK		EXDMA Ca
0008 281Eh	EXDMA C0	EXDMA Status Register	EDMSTS	8	8	1, 2 BCLK		EXDMA Ca
0008 2820h	EXDMA C0	EXDMA External Request Sense Mode Register	EDMRMD	8	8	1, 2 BCLK		EXDMA Ca
0008 2821h	EXDMA C0	EXDMA External Request Flag Register	EDMERF	8	8	1, 2 BCLK		EXDMA Ca
0008 2822h	EXDMA C0	EXDMA Peripheral Request Flag Register	EDMPRF	8	8	1, 2 BCLK		EXDMA Ca
0008 2840h	EXDMA C1	EXDMA Source Address Register	EDMSAR	32	32	1, 2 BCLK		EXDMA Ca
0008 2844h	EXDMA C1	EXDMA Destination Address Register	EDMDAR	32	32	1, 2 BCLK		EXDMA Ca
0008 2848h	EXDMA C1	EXDMA Transfer Count Register	EDMCRA	32	32	1, 2 BCLK		EXDMA Ca
0008 284Ch	EXDMA C1	EXDMA Block Transfer Count Register	EDMCRB	16	16	1, 2 BCLK		EXDMA Ca
0008 2850h	EXDMA C1	EXDMA Transfer Mode Register	EDMTMD	16	16	1, 2 BCLK		EXDMA Ca
0008 2852h	EXDMA C1	EXDMA Output Setting Register	EDMOMD	8	8	1, 2 BCLK		EXDMA Ca
0008 2853h	EXDMA C1	EXDMA Interrupt Setting Register	EDMINT	8	8	1, 2 BCLK		EXDMA Ca
0008 2854h	EXDMA C1	EXDMA Address Mode Register	EDMAMD	32	32	1, 2 BCLK		EXDMA Ca
0008 285Ch	EXDMA C1	EXDMA Transfer Enable Register	EDMCNT	8	8	1, 2 BCLK		EXDMA Ca

Table 4.1 List of I/O Registers (Address Order) (6 / 70)

Address	Module Symbol	Register Name	Register Symbol	Number of Bits	Access Size	Number of Access Cycles		Related Function
						ICLK ≥ PCLK	ICLK < PCLK	
0008 285Dh	EXDMA C1	EXDMA Software Start Register	EDMREQ	8	8	1, 2 BCLK		EXDMA Ca
0008 285Eh	EXDMA C1	EXDMA Status Register	EDMSTS	8	8	1, 2 BCLK		EXDMA Ca
0008 2860h	EXDMA C1	EXDMA External Request Sense Mode Register	EDMRMD	8	8	1, 2 BCLK		EXDMA Ca
0008 2861h	EXDMA C1	EXDMA External Request Flag Register	EDMERF	8	8	1, 2 BCLK		EXDMA Ca
0008 2862h	EXDMA C1	EXDMA Peripheral Request Flag Register	EDMPRF	8	8	1, 2 BCLK		EXDMA Ca
0008 2A00h	EXDMA C	EXDMAC Module Start Register	EDMAST	8	8	1, 2 BCLK		EXDMA Ca
0008 2BE0h	EXDMA C	Cluster Buffer Register 0	CLSBR0	32	32	1, 2 BCLK		EXDMA Ca
0008 2BE4h	EXDMA C	Cluster Buffer Register 1	CLSBR1	32	32	1, 2 BCLK		EXDMA Ca
0008 2BE8h	EXDMA C	Cluster Buffer Register 2	CLSBR2	32	32	1, 2 BCLK		EXDMA Ca
0008 2BECh	EXDMA C	Cluster Buffer Register 3	CLSBR3	32	32	1, 2 BCLK		EXDMA Ca
0008 2BF0h	EXDMA C	Cluster Buffer Register 4	CLSBR4	32	32	1, 2 BCLK		EXDMA Ca
0008 2BF4h	EXDMA C	Cluster Buffer Register 5	CLSBR5	32	32	1, 2 BCLK		EXDMA Ca
0008 2BF8h	EXDMA C	Cluster Buffer Register 6	CLSBR6	32	32	1, 2 BCLK		EXDMA Ca
0008 2BFCh	EXDMA C	Cluster Buffer Register 7	CLSBR7	32	32	1, 2 BCLK		EXDMA Ca
0008 3002h	BSC	CS0 Mode Register	CS0MOD	16	16	1, 2 BCLK		Buses
0008 3004h	BSC	CS0 Wait Control Register 1	CS0WCR1	32	32	1, 2 BCLK		Buses
0008 3008h	BSC	CS0 Wait Control Register 2	CS0WCR2	32	32	1, 2 BCLK		Buses
0008 3012h	BSC	CS1 Mode Register	CS1MOD	16	16	1, 2 BCLK		Buses
0008 3014h	BSC	CS1 Wait Control Register 1	CS1WCR1	32	32	1, 2 BCLK		Buses
0008 3018h	BSC	CS1 Wait Control Register 2	CS1WCR2	32	32	1, 2 BCLK		Buses
0008 3022h	BSC	CS2 Mode Register	CS2MOD	16	16	1, 2 BCLK		Buses
0008 3024h	BSC	CS2 Wait Control Register 1	CS2WCR1	32	32	1, 2 BCLK		Buses
0008 3028h	BSC	CS2 Wait Control Register 2	CS2WCR2	32	32	1, 2 BCLK		Buses
0008 3032h	BSC	CS3 Mode Register	CS3MOD	16	16	1, 2 BCLK		Buses
0008 3034h	BSC	CS3 Wait Control Register 1	CS3WCR1	32	32	1, 2 BCLK		Buses
0008 3038h	BSC	CS3 Wait Control Register 2	CS3WCR2	32	32	1, 2 BCLK		Buses
0008 3042h	BSC	CS4 Mode Register	CS4MOD	16	16	1, 2 BCLK		Buses
0008 3044h	BSC	CS4 Wait Control Register 1	CS4WCR1	32	32	1, 2 BCLK		Buses
0008 3048h	BSC	CS4 Wait Control Register 2	CS4WCR2	32	32	1, 2 BCLK		Buses
0008 3052h	BSC	CS5 Mode Register	CS5MOD	16	16	1, 2 BCLK		Buses
0008 3054h	BSC	CS5 Wait Control Register 1	CS5WCR1	32	32	1, 2 BCLK		Buses
0008 3058h	BSC	CS5 Wait Control Register 2	CS5WCR2	32	32	1, 2 BCLK		Buses
0008 3062h	BSC	CS6 Mode Register	CS6MOD	16	16	1, 2 BCLK		Buses
0008 3064h	BSC	CS6 Wait Control Register 1	CS6WCR1	32	32	1, 2 BCLK		Buses
0008 3068h	BSC	CS6 Wait Control Register 2	CS6WCR2	32	32	1, 2 BCLK		Buses
0008 3072h	BSC	CS7 Mode Register	CS7MOD	16	16	1, 2 BCLK		Buses
0008 3074h	BSC	CS7 Wait Control Register 1	CS7WCR1	32	32	1, 2 BCLK		Buses
0008 3078h	BSC	CS7 Wait Control Register 2	CS7WCR2	32	32	1, 2 BCLK		Buses
0008 3802h	BSC	CS0 Control Register	CS0CR	16	16	1, 2 BCLK		Buses
0008 380Ah	BSC	CS0 Recovery Cycle Register	CS0REC	16	16	1, 2 BCLK		Buses
0008 3812h	BSC	CS1 Control Register	CS1CR	16	16	1, 2 BCLK		Buses
0008 381Ah	BSC	CS1 Recovery Cycle Register	CS1REC	16	16	1, 2 BCLK		Buses

Table 4.1 List of I/O Registers (Address Order) (7 / 70)

Address	Module Symbol	Register Name	Register Symbol	Number of Bits	Access Size	Number of Access Cycles		Related Function
						ICLK ≥ PCLK	ICLK < PCLK	
0008 3822h	BSC	CS2 Control Register	CS2CR	16	16	1, 2	BCLK	Buses
0008 382Ah	BSC	CS2 Recovery Cycle Register	CS2REC	16	16	1, 2	BCLK	Buses
0008 3832h	BSC	CS3 Control Register	CS3CR	16	16	1, 2	BCLK	Buses
0008 383Ah	BSC	CS3 Recovery Cycle Register	CS3REC	16	16	1, 2	BCLK	Buses
0008 3842h	BSC	CS4 Control Register	CS4CR	16	16	1, 2	BCLK	Buses
0008 384Ah	BSC	CS4 Recovery Cycle Register	CS4REC	16	16	1, 2	BCLK	Buses
0008 3852h	BSC	CS5 Control Register	CS5CR	16	16	1, 2	BCLK	Buses
0008 385Ah	BSC	CS5 Recovery Cycle Register	CS5REC	16	16	1, 2	BCLK	Buses
0008 3862h	BSC	CS6 Control Register	CS6CR	16	16	1, 2	BCLK	Buses
0008 386Ah	BSC	CS6 Recovery Cycle Register	CS6REC	16	16	1, 2	BCLK	Buses
0008 3872h	BSC	CS7 Control Register	CS7CR	16	16	1, 2	BCLK	Buses
0008 387Ah	BSC	CS7 Recovery Cycle Register	CS7REC	16	16	1, 2	BCLK	Buses
0008 3880h	BSC	CS Recovery Cycle Insertion Enable Register	CSREGEN	16	16	1, 2	BCLK	Buses
0008 3C00h	BSC	SDC Control Register	SDCCR	8	8	1, 2	BCLK	Buses
0008 3C01h	BSC	SDC Mode Register	SDCMOD	8	8	1, 2	BCLK	Buses
0008 3C02h	BSC	SDRAM Access Mode Register	SDAMOD	8	8	1, 2	BCLK	Buses
0008 3C10h	BSC	SDRAM Self-Refresh Control Register	SDSELF	8	8	1, 2	BCLK	Buses
0008 3C14h	BSC	SDRAM Refresh Control Register	SDRFRCR	16	16	1, 2	BCLK	Buses
0008 3C16h	BSC	SDRAM Auto-Refresh Control Register	SDRFEN	8	8	1, 2	BCLK	Buses
0008 3C20h	BSC	SDRAM Initialization Sequence Control Register	SDICR	8	8	1, 2	BCLK	Buses
0008 3C24h	BSC	SDRAM Initialization Register	SDIR	16	16	1, 2	BCLK	Buses
0008 3C40h	BSC	SDRAM Address Register	SDADR	8	8	1, 2	BCLK	Buses
0008 3C44h	BSC	SDRAM Timing Register	SDTR	32	32	1, 2	BCLK	Buses
0008 3C48h	BSC	SDRAM Mode Register	SDMOD	16	16	1, 2	BCLK	Buses
0008 3C50h	BSC	SDRAM Status Register	SDSR	8	8	1, 2	BCLK	Buses
0008 6400h	MPU	Region-0 Start Page Number Register	RSPAGE0	32	32	1	ICLK	MPU
0008 6404h	MPU	Region-0 End Page Number Register	REPAGE0	32	32	1	ICLK	MPU
0008 6408h	MPU	Region-1 Start Page Number Register	RSPAGE1	32	32	1	ICLK	MPU
0008 640Ch	MPU	Region-1 End Page Number Register	REPAGE1	32	32	1	ICLK	MPU
0008 6410h	MPU	Region-2 Start Page Number Register	RSPAGE2	32	32	1	ICLK	MPU
0008 6414h	MPU	Region-2 End Page Number Register	REPAGE2	32	32	1	ICLK	MPU
0008 6418h	MPU	Region-3 Start Page Number Register	RSPAGE3	32	32	1	ICLK	MPU
0008 641Ch	MPU	Region-3 End Page Number Register	REPAGE3	32	32	1	ICLK	MPU
0008 6420h	MPU	Region-4 Start Page Number Register	RSPAGE4	32	32	1	ICLK	MPU
0008 6424h	MPU	Region-4 End Page Number Register	REPAGE4	32	32	1	ICLK	MPU
0008 6428h	MPU	Region-5 Start Page Number Register	RSPAGE5	32	32	1	ICLK	MPU
0008 642Ch	MPU	Region-5 End Page Number Register	REPAGE5	32	32	1	ICLK	MPU
0008 6430h	MPU	Region-6 Start Page Number Register	RSPAGE6	32	32	1	ICLK	MPU
0008 6434h	MPU	Region-6 End Page Number Register	REPAGE6	32	32	1	ICLK	MPU
0008 6438h	MPU	Region-7 Start Page Number Register	RSPAGE7	32	32	1	ICLK	MPU
0008 643Ch	MPU	Region-7 End Page Number Register	REPAGE7	32	32	1	ICLK	MPU
0008 6500h	MPU	Memory-Protection Enable Register	MPEN	32	32	1	ICLK	MPU
0008 6504h	MPU	Background Access Control Register	MPBAC	32	32	1	ICLK	MPU
0008 6508h	MPU	Memory-Protection Error Status-Clearing Register	MPECLR	32	32	1	ICLK	MPU
0008 650Ch	MPU	Memory-Protection Error Status Register	MPESTS	32	32	1	ICLK	MPU
0008 6514h	MPU	Data Memory-Protection Error Address Register	MPDEA	32	32	1	ICLK	MPU
0008 6520h	MPU	Region Search Address Register	MPSA	32	32	1	ICLK	MPU
0008 6524h	MPU	Region Search Operation Register	MPOPS	16	16	1	ICLK	MPU
0008 6526h	MPU	Region Invalidation Operation Register	MPOPI	16	16	1	ICLK	MPU
0008 6528h	MPU	Instruction-Hit Region Register	MHITI	32	32	1	ICLK	MPU

Table 4.1 List of I/O Registers (Address Order) (8 / 70)

Address	Module Symbol	Register Name	Register Symbol	Number of Bits	Access Size	Number of Access Cycles		Related Function
						ICLK ≥ PCLK	ICLK < PCLK	
0008 652Ch	MPU	Data-Hit Region Register	MHITD	32	32	1 ICLK		MPU
0008 6610h	SYSTEM	Memory Wait Cycle Setting Register	MEMWAIT	32	32	1 ICLK		Clock Generation Circuit
0008 7010h to 0008 70FFh	ICU	Interrupt Request Register 016 to Interrupt Request Register 255	IR016 to IR255	8	8	2 ICLK		ICUA
0008 711Ah to 0008 71FFh	ICU	DTC Transfer Request Enable Register 026 to DTC Transfer Request Enable Register 255	DTCE026 to DTCE255	8	8	2 ICLK		ICUA
0008 7202h to 0008 721Fh	ICU	Interrupt Request Enable Register 02 to Interrupt Request Enable Register 1F	IER02 to IER1F	8	8	2 ICLK		ICUA
0008 72E0h	ICU	Software Interrupt Generation Register	SWINTR	8	8	2 ICLK		ICUA
0008 72E1h	ICU	Software Interrupt 2 Generation Register	SWINT2R	8	8	2 ICLK		ICUA
0008 72F0h	ICU	Fast Interrupt Set Register	FIR	16	16	2 ICLK		ICUA
0008 7300h to 0008 73FFh	ICU	Interrupt Source Priority Register 000 to Interrupt Source Priority Register 255	IPR000 to IPR255	8	8	2 ICLK		ICUA
0008 7400h	ICU	DMAC Trigger Select Register 0	DMRSR0	8	8	2 ICLK		ICUA
0008 7404h	ICU	DMAC Trigger Select Register 1	DMRSR1	8	8	2 ICLK		ICUA
0008 7408h	ICU	DMAC Trigger Select Register 2	DMRSR2	8	8	2 ICLK		ICUA
0008 740Ch	ICU	DMAC Trigger Select Register 3	DMRSR3	8	8	2 ICLK		ICUA
0008 7410h	ICU	DMAC Trigger Select Register 4	DMRSR4	8	8	2 ICLK		ICUA
0008 7414h	ICU	DMAC Trigger Select Register 5	DMRSR5	8	8	2 ICLK		ICUA
0008 7418h	ICU	DMAC Trigger Select Register 6	DMRSR6	8	8	2 ICLK		ICUA
0008 741Ch	ICU	DMAC Trigger Select Register 7	DMRSR7	8	8	2 ICLK		ICUA
0008 7500h to 0008 75FFh	ICU	IRQ Control Register 0 to IRQ Control Register 15	IRQCR0 to IRQCR15	8	8	2 ICLK		ICUA
0008 7520h	ICU	IRQ Pin Digital Filter Enable Register 0	IRQFLTE0	8	8	2 ICLK		ICUA
0008 7521h	ICU	IRQ Pin Digital Filter Enable Register 1	IRQFLTE1	8	8	2 ICLK		ICUA
0008 7528h	ICU	IRQ Pin Digital Filter Setting Register 0	IRQFLTC0	16	16	2 ICLK		ICUA
0008 752Ah	ICU	IRQ Pin Digital Filter Setting Register 1	IRQFLTC1	16	16	2 ICLK		ICUA
0008 7580h	ICU	Non-Maskable Interrupt Status Register	NMISR	8	8	2 ICLK		ICUA
0008 7581h	ICU	Non-Maskable Interrupt Enable Register	NMIER	8	8	2 ICLK		ICUA
0008 7582h	ICU	Non-Maskable Interrupt Status Clear Register	NMICLR	8	8	2 ICLK		ICUA
0008 7583h	ICU	NMI Pin Interrupt Control Register	NMICR	8	8	2 ICLK		ICUA
0008 7590h	ICU	NMI Pin Digital Filter Enable Register	NMIFLTE	8	8	2 ICLK		ICUA
0008 7594h	ICU	NMI Pin Digital Filter Setting Register	NMIFLTC	8	8	2 ICLK		ICUA
0008 7600h	ICU	Group BE0 Interrupt Request Register	GRPBEO	32	32	2 ICLK to 1 PCLKB	2 ICLK	ICUA
0008 7630h	ICU	Group BL0 Interrupt Request Register	GRPBL0	32	32	2 ICLK to 1 PCLKB	2 ICLK	ICUA
0008 7634h	ICU	Group BL1 Interrupt Request Register	GRPBL1	32	32	2 ICLK to 1 PCLKB	2 ICLK	ICUA
0008 7640h	ICU	Group BE0 Interrupt Request Enable Register	GENBEO	32	32	2 ICLK to 1 PCLKB	2 ICLK	ICUA
0008 7670h	ICU	Group BL0 Interrupt Request Enable Register	GENBL0	32	32	2 ICLK to 1 PCLKB	2 ICLK	ICUA
0008 7674h	ICU	Group BL1 Interrupt Request Enable Register	GENBL1	32	32	2 ICLK to 1 PCLKB	2 ICLK	ICUA
0008 7680h	ICU	Group BE0 Interrupt Clear Register	GCRBEO	32	32	2 ICLK to 1 PCLKB	2 ICLK	ICUA
0008 7700h	ICU	Software Configurable Interrupt B Request Register 0	PIBR0	8	8	2 ICLK to 1 PCLKB	2 ICLK	ICUA
0008 7701h	ICU	Software Configurable Interrupt B Request Register 1	PIBR1	8	8	2 ICLK to 1 PCLKB	2 ICLK	ICUA
0008 7702h	ICU	Software Configurable Interrupt B Request Register 2	PIBR2	8	8	2 ICLK to 1 PCLKB	2 ICLK	ICUA
0008 7703h	ICU	Software Configurable Interrupt B Request Register 3	PIBR3	8	8	2 ICLK to 1 PCLKB	2 ICLK	ICUA
0008 7704h	ICU	Software Configurable Interrupt B Request Register 4	PIBR4	8	8	2 ICLK to 1 PCLKB	2 ICLK	ICUA

Table 4.1 List of I/O Registers (Address Order) (9 / 70)

Address	Module Symbol	Register Name	Register Symbol	Number of Bits	Access Size	Number of Access Cycles		Related Function
						ICLK ≥ PCLK	ICLK < PCLK	
0008 7705h	ICU	Software Configurable Interrupt B Request Register 5	PIBR5	8	8	2 ICLK to 1 PCLKB	2 ICLK	ICUA
0008 7706h	ICU	Software Configurable Interrupt B Request Register 6	PIBR6	8	8	2 ICLK to 1 PCLKB	2 ICLK	ICUA
0008 7707h	ICU	Software Configurable Interrupt B Request Register 7	PIBR7	8	8	2 ICLK to 1 PCLKB	2 ICLK	ICUA
0008 7708h	ICU	Software Configurable Interrupt B Request Register 8	PIBR8	8	8	2 ICLK to 1 PCLKB	2 ICLK	ICUA
0008 7709h	ICU	Software Configurable Interrupt B Request Register 9	PIBR9	8	8	2 ICLK to 1 PCLKB	2 ICLK	ICUA
0008 770Ah	ICU	Software Configurable Interrupt B Request Register A	PIBRA	8	8	2 ICLK to 1 PCLKB	2 ICLK	ICUA
0008 7780h	ICU	Software Configurable Interrupt B Source Select Register X128	SLIBXR128	8	8	2 ICLK to 1 PCLKB	2 ICLK	ICUA
0008 7781h	ICU	Software Configurable Interrupt B Source Select Register X129	SLIBXR129	8	8	2 ICLK to 1 PCLKB	2 ICLK	ICUA
0008 7782h	ICU	Software Configurable Interrupt B Source Select Register X130	SLIBXR130	8	8	2 ICLK to 1 PCLKB	2 ICLK	ICUA
0008 7783h	ICU	Software Configurable Interrupt B Source Select Register X131	SLIBXR131	8	8	2 ICLK to 1 PCLKB	2 ICLK	ICUA
0008 7784h	ICU	Software Configurable Interrupt B Source Select Register X132	SLIBXR132	8	8	2 ICLK to 1 PCLKB	2 ICLK	ICUA
0008 7785h	ICU	Software Configurable Interrupt B Source Select Register X133	SLIBXR133	8	8	2 ICLK to 1 PCLKB	2 ICLK	ICUA
0008 7786h	ICU	Software Configurable Interrupt B Source Select Register X134	SLIBXR134	8	8	2 ICLK to 1 PCLKB	2 ICLK	ICUA
0008 7787h	ICU	Software Configurable Interrupt B Source Select Register X135	SLIBXR135	8	8	2 ICLK to 1 PCLKB	2 ICLK	ICUA
0008 7788h	ICU	Software Configurable Interrupt B Source Select Register X136	SLIBXR136	8	8	2 ICLK to 1 PCLKB	2 ICLK	ICUA
0008 7789h	ICU	Software Configurable Interrupt B Source Select Register X137	SLIBXR137	8	8	2 ICLK to 1 PCLKB	2 ICLK	ICUA
0008 778Ah	ICU	Software Configurable Interrupt B Source Select Register X138	SLIBXR138	8	8	2 ICLK to 1 PCLKB	2 ICLK	ICUA
0008 778Bh	ICU	Software Configurable Interrupt B Source Select Register X139	SLIBXR139	8	8	2 ICLK to 1 PCLKB	2 ICLK	ICUA
0008 778Ch	ICU	Software Configurable Interrupt B Source Select Register X140	SLIBXR140	8	8	2 ICLK to 1 PCLKB	2 ICLK	ICUA
0008 778Dh	ICU	Software Configurable Interrupt B Source Select Register X141	SLIBXR141	8	8	2 ICLK to 1 PCLKB	2 ICLK	ICUA
0008 778Eh	ICU	Software Configurable Interrupt B Source Select Register X142	SLIBXR142	8	8	2 ICLK to 1 PCLKB	2 ICLK	ICUA
0008 778Fh	ICU	Software Configurable Interrupt B Source Select Register X143	SLIBXR143	8	8	2 ICLK to 1 PCLKB	2 ICLK	ICUA
0008 7790h	ICU	Software Configurable Interrupt B Source Select Register 144	SLIBR144	8	8	2 ICLK to 1 PCLKB	2 ICLK	ICUA
0008 7791h	ICU	Software Configurable Interrupt B Source Select Register 145	SLIBR145	8	8	2 ICLK to 1 PCLKB	2 ICLK	ICUA
0008 7792h	ICU	Software Configurable Interrupt B Source Select Register 146	SLIBR146	8	8	2 ICLK to 1 PCLKB	2 ICLK	ICUA
0008 7793h	ICU	Software Configurable Interrupt B Source Select Register 147	SLIBR147	8	8	2 ICLK to 1 PCLKB	2 ICLK	ICUA
0008 7794h	ICU	Software Configurable Interrupt B Source Select Register 148	SLIBR148	8	8	2 ICLK to 1 PCLKB	2 ICLK	ICUA
0008 7795h	ICU	Software Configurable Interrupt B Source Select Register 149	SLIBR149	8	8	2 ICLK to 1 PCLKB	2 ICLK	ICUA
0008 7796h	ICU	Software Configurable Interrupt B Source Select Register 150	SLIBR150	8	8	2 ICLK to 1 PCLKB	2 ICLK	ICUA
0008 7797h	ICU	Software Configurable Interrupt B Source Select Register 151	SLIBR151	8	8	2 ICLK to 1 PCLKB	2 ICLK	ICUA
0008 7798h	ICU	Software Configurable Interrupt B Source Select Register 152	SLIBR152	8	8	2 ICLK to 1 PCLKB	2 ICLK	ICUA
0008 7799h	ICU	Software Configurable Interrupt B Source Select Register 153	SLIBR153	8	8	2 ICLK to 1 PCLKB	2 ICLK	ICUA

Table 4.1 List of I/O Registers (Address Order) (10 / 70)

Address	Module Symbol	Register Name	Register Symbol	Number of Bits	Access Size	Number of Access Cycles		Related Function
						ICLK ≥ PCLK	ICLK < PCLK	
0008 779Ah	ICU	Software Configurable Interrupt B Source Select Register 154	SLIBR154	8	8	2 ICLK to 1 PCLKB	2 ICLK	ICUA
0008 779Bh	ICU	Software Configurable Interrupt B Source Select Register 155	SLIBR155	8	8	2 ICLK to 1 PCLKB	2 ICLK	ICUA
0008 779Ch	ICU	Software Configurable Interrupt B Source Select Register 156	SLIBR156	8	8	2 ICLK to 1 PCLKB	2 ICLK	ICUA
0008 779Dh	ICU	Software Configurable Interrupt B Source Select Register 157	SLIBR157	8	8	2 ICLK to 1 PCLKB	2 ICLK	ICUA
0008 779Eh	ICU	Software Configurable Interrupt B Source Select Register 158	SLIBR158	8	8	2 ICLK to 1 PCLKB	2 ICLK	ICUA
0008 779Fh	ICU	Software Configurable Interrupt B Source Select Register 159	SLIBR159	8	8	2 ICLK to 1 PCLKB	2 ICLK	ICUA
0008 77A0h	ICU	Software Configurable Interrupt B Source Select Register 160	SLIBR160	8	8	2 ICLK to 1 PCLKB	2 ICLK	ICUA
0008 77A1h	ICU	Software Configurable Interrupt B Source Select Register 161	SLIBR161	8	8	2 ICLK to 1 PCLKB	2 ICLK	ICUA
0008 77A2h	ICU	Software Configurable Interrupt B Source Select Register 162	SLIBR162	8	8	2 ICLK to 1 PCLKB	2 ICLK	ICUA
0008 77A3h	ICU	Software Configurable Interrupt B Source Select Register 163	SLIBR163	8	8	2 ICLK to 1 PCLKB	2 ICLK	ICUA
0008 77A4h	ICU	Software Configurable Interrupt B Source Select Register 164	SLIBR164	8	8	2 ICLK to 1 PCLKB	2 ICLK	ICUA
0008 77A5h	ICU	Software Configurable Interrupt B Source Select Register 165	SLIBR165	8	8	2 ICLK to 1 PCLKB	2 ICLK	ICUA
0008 77A6h	ICU	Software Configurable Interrupt B Source Select Register 166	SLIBR166	8	8	2 ICLK to 1 PCLKB	2 ICLK	ICUA
0008 77A7h	ICU	Software Configurable Interrupt B Source Select Register 167	SLIBR167	8	8	2 ICLK to 1 PCLKB	2 ICLK	ICUA
0008 77A8h	ICU	Software Configurable Interrupt B Source Select Register 168	SLIBR168	8	8	2 ICLK to 1 PCLKB	2 ICLK	ICUA
0008 77A9h	ICU	Software Configurable Interrupt B Source Select Register 169	SLIBR169	8	8	2 ICLK to 1 PCLKB	2 ICLK	ICUA
0008 77AAh	ICU	Software Configurable Interrupt B Source Select Register 170	SLIBR170	8	8	2 ICLK to 1 PCLKB	2 ICLK	ICUA
0008 77ABh	ICU	Software Configurable Interrupt B Source Select Register 171	SLIBR171	8	8	2 ICLK to 1 PCLKB	2 ICLK	ICUA
0008 77ACh	ICU	Software Configurable Interrupt B Source Select Register 172	SLIBR172	8	8	2 ICLK to 1 PCLKB	2 ICLK	ICUA
0008 77ADh	ICU	Software Configurable Interrupt B Source Select Register 173	SLIBR173	8	8	2 ICLK to 1 PCLKB	2 ICLK	ICUA
0008 77AEh	ICU	Software Configurable Interrupt B Source Select Register 174	SLIBR174	8	8	2 ICLK to 1 PCLKB	2 ICLK	ICUA
0008 77AFh	ICU	Software Configurable Interrupt B Source Select Register 175	SLIBR175	8	8	2 ICLK to 1 PCLKB	2 ICLK	ICUA
0008 77B0h	ICU	Software Configurable Interrupt B Source Select Register 176	SLIBR176	8	8	2 ICLK to 1 PCLKB	2 ICLK	ICUA
0008 77B1h	ICU	Software Configurable Interrupt B Source Select Register 177	SLIBR177	8	8	2 ICLK to 1 PCLKB	2 ICLK	ICUA
0008 77B2h	ICU	Software Configurable Interrupt B Source Select Register 178	SLIBR178	8	8	2 ICLK to 1 PCLKB	2 ICLK	ICUA
0008 77B3h	ICU	Software Configurable Interrupt B Source Select Register 179	SLIBR179	8	8	2 ICLK to 1 PCLKB	2 ICLK	ICUA
0008 77B4h	ICU	Software Configurable Interrupt B Source Select Register 180	SLIBR180	8	8	2 ICLK to 1 PCLKB	2 ICLK	ICUA
0008 77B5h	ICU	Software Configurable Interrupt B Source Select Register 181	SLIBR181	8	8	2 ICLK to 1 PCLKB	2 ICLK	ICUA
0008 77B6h	ICU	Software Configurable Interrupt B Source Select Register 182	SLIBR182	8	8	2 ICLK to 1 PCLKB	2 ICLK	ICUA
0008 77B7h	ICU	Software Configurable Interrupt B Source Select Register 183	SLIBR183	8	8	2 ICLK to 1 PCLKB	2 ICLK	ICUA
0008 77B8h	ICU	Software Configurable Interrupt B Source Select Register 184	SLIBR184	8	8	2 ICLK to 1 PCLKB	2 ICLK	ICUA

Table 4.1 List of I/O Registers (Address Order) (11 / 70)

Address	Module Symbol	Register Name	Register Symbol	Number of Bits	Access Size	Number of Access Cycles		Related Function
						ICLK ≥ PCLK	ICLK < PCLK	
0008 77B9h	ICU	Software Configurable Interrupt B Source Select Register 185	SLIBR185	8	8	2 ICLK to 1 PCLKB	2 ICLK	ICUA
0008 77BAh	ICU	Software Configurable Interrupt B Source Select Register 186	SLIBR186	8	8	2 ICLK to 1 PCLKB	2 ICLK	ICUA
0008 77BBh	ICU	Software Configurable Interrupt B Source Select Register 187	SLIBR187	8	8	2 ICLK to 1 PCLKB	2 ICLK	ICUA
0008 77BCh	ICU	Software Configurable Interrupt B Source Select Register 188	SLIBR188	8	8	2 ICLK to 1 PCLKB	2 ICLK	ICUA
0008 77BDh	ICU	Software Configurable Interrupt B Source Select Register 189	SLIBR189	8	8	2 ICLK to 1 PCLKB	2 ICLK	ICUA
0008 77BEh	ICU	Software Configurable Interrupt B Source Select Register 190	SLIBR190	8	8	2 ICLK to 1 PCLKB	2 ICLK	ICUA
0008 77BFh	ICU	Software Configurable Interrupt B Source Select Register 191	SLIBR191	8	8	2 ICLK to 1 PCLKB	2 ICLK	ICUA
0008 77C0h	ICU	Software Configurable Interrupt B Source Select Register 192	SLIBR192	8	8	2 ICLK to 1 PCLKB	2 ICLK	ICUA
0008 77C1h	ICU	Software Configurable Interrupt B Source Select Register 193	SLIBR193	8	8	2 ICLK to 1 PCLKB	2 ICLK	ICUA
0008 77C2h	ICU	Software Configurable Interrupt B Source Select Register 194	SLIBR194	8	8	2 ICLK to 1 PCLKB	2 ICLK	ICUA
0008 77C3h	ICU	Software Configurable Interrupt B Source Select Register 195	SLIBR195	8	8	2 ICLK to 1 PCLKB	2 ICLK	ICUA
0008 77C4h	ICU	Software Configurable Interrupt B Source Select Register 196	SLIBR196	8	8	2 ICLK to 1 PCLKB	2 ICLK	ICUA
0008 77C5h	ICU	Software Configurable Interrupt B Source Select Register 197	SLIBR197	8	8	2 ICLK to 1 PCLKB	2 ICLK	ICUA
0008 77C6h	ICU	Software Configurable Interrupt B Source Select Register 198	SLIBR198	8	8	2 ICLK to 1 PCLKB	2 ICLK	ICUA
0008 77C7h	ICU	Software Configurable Interrupt B Source Select Register 199	SLIBR199	8	8	2 ICLK to 1 PCLKB	2 ICLK	ICUA
0008 77C8h	ICU	Software Configurable Interrupt B Source Select Register 200	SLIBR200	8	8	2 ICLK to 1 PCLKB	2 ICLK	ICUA
0008 77C9h	ICU	Software Configurable Interrupt B Source Select Register 201	SLIBR201	8	8	2 ICLK to 1 PCLKB	2 ICLK	ICUA
0008 77CAh	ICU	Software Configurable Interrupt B Source Select Register 202	SLIBR202	8	8	2 ICLK to 1 PCLKB	2 ICLK	ICUA
0008 77CBh	ICU	Software Configurable Interrupt B Source Select Register 203	SLIBR203	8	8	2 ICLK to 1 PCLKB	2 ICLK	ICUA
0008 77CCh	ICU	Software Configurable Interrupt B Source Select Register 204	SLIBR204	8	8	2 ICLK to 1 PCLKB	2 ICLK	ICUA
0008 77CDh	ICU	Software Configurable Interrupt B Source Select Register 205	SLIBR205	8	8	2 ICLK to 1 PCLKB	2 ICLK	ICUA
0008 77CEh	ICU	Software Configurable Interrupt B Source Select Register 206	SLIBR206	8	8	2 ICLK to 1 PCLKB	2 ICLK	ICUA
0008 77CFh	ICU	Software Configurable Interrupt B Source Select Register 207	SLIBR207	8	8	2 ICLK to 1 PCLKB	2 ICLK	ICUA
0008 7830h	ICU	Group AL0 Interrupt Request Register	GRPAL0	32	32	2 ICLK to 1 PCLKA	2 ICLK	ICUA
0008 7834h	ICU	Group AL1 Interrupt Request Register	GRPAL1	32	32	2 ICLK to 1 PCLKA	2 ICLK	ICUA
0008 7870h	ICU	Group AL0 Interrupt Request Enable Register	GENAL0	32	32	2 ICLK to 1 PCLKA	2 ICLK	ICUA
0008 7874h	ICU	Group AL1 Interrupt Request Enable Register	GENAL1	32	32	2 ICLK to 1 PCLKA	2 ICLK	ICUA
0008 7900h	ICU	Software Configurable Interrupt A Request Register 0	PIAR0	8	8	2 ICLK to 1 PCLKA	2 ICLK	ICUA
0008 7901h	ICU	Software Configurable Interrupt A Request Register 1	PIAR1	8	8	2 ICLK to 1 PCLKA	2 ICLK	ICUA
0008 7902h	ICU	Software Configurable Interrupt A Request Register 2	PIAR2	8	8	2 ICLK to 1 PCLKA	2 ICLK	ICUA
0008 7903h	ICU	Software Configurable Interrupt A Request Register 3	PIAR3	8	8	2 ICLK to 1 PCLKA	2 ICLK	ICUA
0008 7904h	ICU	Software Configurable Interrupt A Request Register 4	PIAR4	8	8	2 ICLK to 1 PCLKA	2 ICLK	ICUA

Table 4.1 List of I/O Registers (Address Order) (12 / 70)

Address	Module Symbol	Register Name	Register Symbol	Number of Bits	Access Size	Number of Access Cycles		Related Function
						ICLK ≥ PCLK	ICLK < PCLK	
0008 7905h	ICU	Software Configurable Interrupt A Request Register 5	PIAR5	8	8	2 ICLK to 1 PCLKA	2 ICLK	ICUA
0008 7906h	ICU	Software Configurable Interrupt A Request Register 6	PIAR6	8	8	2 ICLK to 1 PCLKA	2 ICLK	ICUA
0008 7907h	ICU	Software Configurable Interrupt A Request Register 7	PIAR7	8	8	2 ICLK to 1 PCLKA	2 ICLK	ICUA
0008 7908h	ICU	Software Configurable Interrupt A Request Register 8	PIAR8	8	8	2 ICLK to 1 PCLKA	2 ICLK	ICUA
0008 7909h	ICU	Software Configurable Interrupt A Request Register 9	PIAR9	8	8	2 ICLK to 1 PCLKA	2 ICLK	ICUA
0008 790Ah	ICU	Software Configurable Interrupt A Request Register A	PIARA	8	8	2 ICLK to 1 PCLKA	2 ICLK	ICUA
0008 790Bh	ICU	Software Configurable Interrupt A Request Register B	PIARB	8	8	2 ICLK to 1 PCLKA	2 ICLK	ICUA
0008 79D0h	ICU	Software Configurable Interrupt A Source Select Register 208	SLIAR208	8	8	2 ICLK to 1 PCLKA	2 ICLK	ICUA
0008 79D1h	ICU	Software Configurable Interrupt A Source Select Register 209	SLIAR209	8	8	2 ICLK to 1 PCLKA	2 ICLK	ICUA
0008 79D2h	ICU	Software Configurable Interrupt A Source Select Register 210	SLIAR210	8	8	2 ICLK to 1 PCLKA	2 ICLK	ICUA
0008 79D3h	ICU	Software Configurable Interrupt A Source Select Register 211	SLIAR211	8	8	2 ICLK to 1 PCLKA	2 ICLK	ICUA
0008 79D4h	ICU	Software Configurable Interrupt A Source Select Register 212	SLIAR212	8	8	2 ICLK to 1 PCLKA	2 ICLK	ICUA
0008 79D5h	ICU	Software Configurable Interrupt A Source Select Register 213	SLIAR213	8	8	2 ICLK to 1 PCLKA	2 ICLK	ICUA
0008 79D6h	ICU	Software Configurable Interrupt A Source Select Register 214	SLIAR214	8	8	2 ICLK to 1 PCLKA	2 ICLK	ICUA
0008 79D7h	ICU	Software Configurable Interrupt A Source Select Register 215	SLIAR215	8	8	2 ICLK to 1 PCLKA	2 ICLK	ICUA
0008 79D8h	ICU	Software Configurable Interrupt A Source Select Register 216	SLIAR216	8	8	2 ICLK to 1 PCLKA	2 ICLK	ICUA
0008 79D9h	ICU	Software Configurable Interrupt A Source Select Register 217	SLIAR217	8	8	2 ICLK to 1 PCLKA	2 ICLK	ICUA
0008 79DAh	ICU	Software Configurable Interrupt A Source Select Register 218	SLIAR218	8	8	2 ICLK to 1 PCLKA	2 ICLK	ICUA
0008 79DBh	ICU	Software Configurable Interrupt A Source Select Register 219	SLIAR219	8	8	2 ICLK to 1 PCLKA	2 ICLK	ICUA
0008 79DCh	ICU	Software Configurable Interrupt A Source Select Register 220	SLIAR220	8	8	2 ICLK to 1 PCLKA	2 ICLK	ICUA
0008 79DDh	ICU	Software Configurable Interrupt A Source Select Register 221	SLIAR221	8	8	2 ICLK to 1 PCLKA	2 ICLK	ICUA
0008 79DEh	ICU	Software Configurable Interrupt A Source Select Register 222	SLIAR222	8	8	2 ICLK to 1 PCLKA	2 ICLK	ICUA
0008 79DFh	ICU	Software Configurable Interrupt A Source Select Register 223	SLIAR223	8	8	2 ICLK to 1 PCLKA	2 ICLK	ICUA
0008 79E0h	ICU	Software Configurable Interrupt A Source Select Register 224	SLIAR224	8	8	2 ICLK to 1 PCLKA	2 ICLK	ICUA
0008 79E1h	ICU	Software Configurable Interrupt A Source Select Register 225	SLIAR225	8	8	2 ICLK to 1 PCLKA	2 ICLK	ICUA
0008 79E2h	ICU	Software Configurable Interrupt A Source Select Register 226	SLIAR226	8	8	2 ICLK to 1 PCLKA	2 ICLK	ICUA
0008 79E3h	ICU	Software Configurable Interrupt A Source Select Register 227	SLIAR227	8	8	2 ICLK to 1 PCLKA	2 ICLK	ICUA
0008 79E4h	ICU	Software Configurable Interrupt A Source Select Register 228	SLIAR228	8	8	2 ICLK to 1 PCLKA	2 ICLK	ICUA
0008 79E5h	ICU	Software Configurable Interrupt A Source Select Register 229	SLIAR229	8	8	2 ICLK to 1 PCLKA	2 ICLK	ICUA
0008 79E6h	ICU	Software Configurable Interrupt A Source Select Register 230	SLIAR230	8	8	2 ICLK to 1 PCLKA	2 ICLK	ICUA
0008 79E7h	ICU	Software Configurable Interrupt A Source Select Register 231	SLIAR231	8	8	2 ICLK to 1 PCLKA	2 ICLK	ICUA
0008 79E8h	ICU	Software Configurable Interrupt A Source Select Register 232	SLIAR232	8	8	2 ICLK to 1 PCLKA	2 ICLK	ICUA

Table 4.1 List of I/O Registers (Address Order) (13 / 70)

Address	Module Symbol	Register Name	Register Symbol	Number of Bits	Access Size	Number of Access Cycles		Related Function
						ICLK ≥ PCLK	ICLK < PCLK	
0008 79E9h	ICU	Software Configurable Interrupt A Source Select Register 233	SLIAR233	8	8	2 ICLK to 1 PCLKA	2 ICLK	ICUA
0008 79EAh	ICU	Software Configurable Interrupt A Source Select Register 234	SLIAR234	8	8	2 ICLK to 1 PCLKA	2 ICLK	ICUA
0008 79EBh	ICU	Software Configurable Interrupt A Source Select Register 235	SLIAR235	8	8	2 ICLK to 1 PCLKA	2 ICLK	ICUA
0008 79ECh	ICU	Software Configurable Interrupt A Source Select Register 236	SLIAR236	8	8	2 ICLK to 1 PCLKA	2 ICLK	ICUA
0008 79EDh	ICU	Software Configurable Interrupt A Source Select Register 237	SLIAR237	8	8	2 ICLK to 1 PCLKA	2 ICLK	ICUA
0008 79EEh	ICU	Software Configurable Interrupt A Source Select Register 238	SLIAR238	8	8	2 ICLK to 1 PCLKA	2 ICLK	ICUA
0008 79EFh	ICU	Software Configurable Interrupt A Source Select Register 239	SLIAR239	8	8	2 ICLK to 1 PCLKA	2 ICLK	ICUA
0008 79F0h	ICU	Software Configurable Interrupt A Source Select Register 240	SLIAR240	8	8	2 ICLK to 1 PCLKA	2 ICLK	ICUA
0008 79F1h	ICU	Software Configurable Interrupt A Source Select Register 241	SLIAR241	8	8	2 ICLK to 1 PCLKA	2 ICLK	ICUA
0008 79F2h	ICU	Software Configurable Interrupt A Source Select Register 242	SLIAR242	8	8	2 ICLK to 1 PCLKA	2 ICLK	ICUA
0008 79F3h	ICU	Software Configurable Interrupt A Source Select Register 243	SLIAR243	8	8	2 ICLK to 1 PCLKA	2 ICLK	ICUA
0008 79F4h	ICU	Software Configurable Interrupt A Source Select Register 244	SLIAR244	8	8	2 ICLK to 1 PCLKA	2 ICLK	ICUA
0008 79F5h	ICU	Software Configurable Interrupt A Source Select Register 245	SLIAR245	8	8	2 ICLK to 1 PCLKA	2 ICLK	ICUA
0008 79F6h	ICU	Software Configurable Interrupt A Source Select Register 246	SLIAR246	8	8	2 ICLK to 1 PCLKA	2 ICLK	ICUA
0008 79F7h	ICU	Software Configurable Interrupt A Source Select Register 247	SLIAR247	8	8	2 ICLK to 1 PCLKA	2 ICLK	ICUA
0008 79F8h	ICU	Software Configurable Interrupt A Source Select Register 248	SLIAR248	8	8	2 ICLK to 1 PCLKA	2 ICLK	ICUA
0008 79F9h	ICU	Software Configurable Interrupt A Source Select Register 249	SLIAR249	8	8	2 ICLK to 1 PCLKA	2 ICLK	ICUA
0008 79FAh	ICU	Software Configurable Interrupt A Source Select Register 250	SLIAR250	8	8	2 ICLK to 1 PCLKA	2 ICLK	ICUA
0008 79FBh	ICU	Software Configurable Interrupt A Source Select Register 251	SLIAR251	8	8	2 ICLK to 1 PCLKA	2 ICLK	ICUA
0008 79FCh	ICU	Software Configurable Interrupt A Source Select Register 252	SLIAR252	8	8	2 ICLK to 1 PCLKA	2 ICLK	ICUA
0008 79FDh	ICU	Software Configurable Interrupt A Source Select Register 253	SLIAR253	8	8	2 ICLK to 1 PCLKA	2 ICLK	ICUA
0008 79FEh	ICU	Software Configurable Interrupt A Source Select Register 254	SLIAR254	8	8	2 ICLK to 1 PCLKA	2 ICLK	ICUA
0008 79FFh	ICU	Software Configurable Interrupt A Source Select Register 255	SLIAR255	8	8	2 ICLK to 1 PCLKA	2 ICLK	ICUA
0008 7A00h	ICU	Software Configurable Interrupt Source Select Register Write Protect Register	SLIPRCR	8	8	2 ICLK to 1 PCLKA/B	2 ICLK	ICUA
0008 7A01h	ICU	EXDMAC Trigger Select Register	SELEXDR	8	8	2 ICLK to 1 PCLKA/B	2 ICLK	ICUA
0008 8000h	CMT	Compare Match Timer Start Register 0	CMSTR0	16	16	2, 3 PCLKB	2 ICLK	CMT
0008 8002h	CMT0	Compare Match Timer Control Register	CMCR	16	16	2, 3 PCLKB	2 ICLK	CMT
0008 8004h	CMT0	Compare Match Counter	CMCNT	16	16	2, 3 PCLKB	2 ICLK	CMT
0008 8006h	CMT0	Compare Match Constant Register	CMCOR	16	16	2, 3 PCLKB	2 ICLK	CMT
0008 8008h	CMT1	Compare Match Timer Control Register	CMCR	16	16	2, 3 PCLKB	2 ICLK	CMT
0008 800Ah	CMT1	Compare Match Counter	CMCNT	16	16	2, 3 PCLKB	2 ICLK	CMT
0008 800Ch	CMT1	Compare Match Constant Register	CMCOR	16	16	2, 3 PCLKB	2 ICLK	CMT
0008 8010h	CMT	Compare Match Timer Start Register 1	CMSTR1	16	16	2, 3 PCLKB	2 ICLK	CMT
0008 8012h	CMT2	Compare Match Timer Control Register	CMCR	16	16	2, 3 PCLKB	2 ICLK	CMT
0008 8014h	CMT2	Compare Match Counter	CMCNT	16	16	2, 3 PCLKB	2 ICLK	CMT
0008 8016h	CMT2	Compare Match Constant Register	CMCOR	16	16	2, 3 PCLKB	2 ICLK	CMT

Table 4.1 List of I/O Registers (Address Order) (14 / 70)

Address	Module Symbol	Register Name	Register Symbol	Number of Bits	Access Size	Number of Access Cycles		Related Function
						ICLK ≥ PCLK	ICLK < PCLK	
0008 8018h	CMT3	Compare Match Timer Control Register	CMCR	16	16	2, 3 PCLKB	2 ICLK	CMT
0008 801Ah	CMT3	Compare Match Counter	CMCNT	16	16	2, 3 PCLKB	2 ICLK	CMT
0008 801Ch	CMT3	Compare Match Constant Register	CMCOR	16	16	2, 3 PCLKB	2 ICLK	CMT
0008 8020h	WDT	WDT Refresh Register	WDTRR	8	8	2, 3 PCLKB	2 ICLK	WDTA
0008 8022h	WDT	WDT Control Register	WDTCR	16	16	2, 3 PCLKB	2 ICLK	WDTA
0008 8024h	WDT	WDT Status Register	WDTSR	16	16	2, 3 PCLKB	2 ICLK	WDTA
0008 8026h	WDT	WDT Reset Control Register	WDTRCR	8	8	2, 3 PCLKB	2 ICLK	WDTA
0008 8030h	IWDT	IWDT Refresh Register	IWDTRR	8	8	2, 3 PCLKB	2 ICLK	IWDTa
0008 8032h	IWDT	IWDT Control Register	IWDTCR	16	16	2, 3 PCLKB	2 ICLK	IWDTa
0008 8034h	IWDT	IWDT Status Register	IWDTSR	16	16	2, 3 PCLKB	2 ICLK	IWDTa
0008 8036h	IWDT	IWDT Reset Control Register	IWDTRCR	8	8	2, 3 PCLKB	2 ICLK	IWDTa
0008 8038h	IWDT	IWDT Count Stop Control Register	IWDCSTPR	8	8	2, 3 PCLKB	2 ICLK	IWDTa
0008 8040h	DA	D/A Data Register 0	DADR0	16	16	2, 3 PCLKB	2 ICLK	R12DA
0008 8042h	DA	D/A Data Register 1	DADR1	16	16	2, 3 PCLKB	2 ICLK	R12DA
0008 8044h	DA	D/A Control Register	DACR	8	8	2, 3 PCLKB	2 ICLK	R12DA
0008 8045h	DA	DADRm Format Select Register	DADPR	8	8	2, 3 PCLKB	2 ICLK	R12DA
0008 8046h	DA	D/A A/D Synchronous Start Control Register	DAADSCR	8	8	2, 3 PCLKB	2 ICLK	R12DA
0008 8048h	DA	D/A Output Amplifier Control Register	DAAMPCR	8	8	2, 3 PCLKB	2 ICLK	R12DA
0008 8100h	TPUA	Timer Start Register	TSTR	8	8	2, 3 PCLKB	2 ICLK	TPUa
0008 8101h	TPUA	Timer Synchronous Register	TSYR	8	8	2, 3 PCLKB	2 ICLK	TPUa
0008 8108h	TPU0	Noise Filter Control Register	NFCR	8	8	2, 3 PCLKB	2 ICLK	TPUa
0008 8109h	TPU1	Noise Filter Control Register	NFCR	8	8	2, 3 PCLKB	2 ICLK	TPUa
0008 810Ah	TPU2	Noise Filter Control Register	NFCR	8	8	2, 3 PCLKB	2 ICLK	TPUa
0008 810Bh	TPU3	Noise Filter Control Register	NFCR	8	8	2, 3 PCLKB	2 ICLK	TPUa
0008 810Ch	TPU4	Noise Filter Control Register	NFCR	8	8	2, 3 PCLKB	2 ICLK	TPUa
0008 810Dh	TPU5	Noise Filter Control Register	NFCR	8	8	2, 3 PCLKB	2 ICLK	TPUa
0008 8110h	TPU0	Timer Control Register	TCR	8	8	2, 3 PCLKB	2 ICLK	TPUa
0008 8111h	TPU0	Timer Mode Register	TMDR	8	8	2, 3 PCLKB	2 ICLK	TPUa
0008 8112h	TPU0	Timer I/O Control Register H	TIORH	8	8	2, 3 PCLKB	2 ICLK	TPUa
0008 8113h	TPU0	Timer I/O Control Register L	TIORL	8	8	2, 3 PCLKB	2 ICLK	TPUa
0008 8114h	TPU0	Timer Interrupt Enable Register	TIER	8	8	2, 3 PCLKB	2 ICLK	TPUa
0008 8115h	TPU0	Timer Status Register	TSR	8	8	2, 3 PCLKB	2 ICLK	TPUa
0008 8116h	TPU0	Timer Counter	TCNT	16	16	2, 3 PCLKB	2 ICLK	TPUa
0008 8118h	TPU0	Timer General Register A	TGRA	16	16	2, 3 PCLKB	2 ICLK	TPUa
0008 811Ah	TPU0	Timer General Register B	TGRB	16	16	2, 3 PCLKB	2 ICLK	TPUa
0008 811Ch	TPU0	Timer General Register C	TGRC	16	16	2, 3 PCLKB	2 ICLK	TPUa
0008 811Eh	TPU0	Timer General Register D	TGRD	16	16	2, 3 PCLKB	2 ICLK	TPUa
0008 8120h	TPU1	Timer Control Register	TCR	8	8	2, 3 PCLKB	2 ICLK	TPUa
0008 8121h	TPU1	Timer Mode Register	TMDR	8	8	2, 3 PCLKB	2 ICLK	TPUa
0008 8122h	TPU1	Timer I/O Control Register	TIOR	8	8	2, 3 PCLKB	2 ICLK	TPUa
0008 8124h	TPU1	Timer Interrupt Enable Register	TIER	8	8	2, 3 PCLKB	2 ICLK	TPUa
0008 8125h	TPU1	Timer Status Register	TSR	8	8	2, 3 PCLKB	2 ICLK	TPUa
0008 8126h	TPU1	Timer Counter	TCNT	16	16	2, 3 PCLKB	2 ICLK	TPUa
0008 8128h	TPU1	Timer General Register A	TGRA	16	16	2, 3 PCLKB	2 ICLK	TPUa
0008 812Ah	TPU1	Timer General Register B	TGRB	16	16	2, 3 PCLKB	2 ICLK	TPUa
0008 8130h	TPU2	Timer Control Register	TCR	8	8	2, 3 PCLKB	2 ICLK	TPUa
0008 8131h	TPU2	Timer Mode Register	TMDR	8	8	2, 3 PCLKB	2 ICLK	TPUa
0008 8132h	TPU2	Timer I/O Control Register	TIOR	8	8	2, 3 PCLKB	2 ICLK	TPUa
0008 8134h	TPU2	Timer Interrupt Enable Register	TIER	8	8	2, 3 PCLKB	2 ICLK	TPUa
0008 8135h	TPU2	Timer Status Register	TSR	8	8	2, 3 PCLKB	2 ICLK	TPUa

Table 4.1 List of I/O Registers (Address Order) (15 / 70)

Address	Module Symbol	Register Name	Register Symbol	Number of Bits	Access Size	Number of Access Cycles		Related Function
						ICLK ≥ PCLK	ICLK < PCLK	
0008 8136h	TPU2	Timer Counter	TCNT	16	16	2, 3 PCLKB	2 ICLK	TPUa
0008 8138h	TPU2	Timer General Register A	TGRA	16	16	2, 3 PCLKB	2 ICLK	TPUa
0008 813Ah	TPU2	Timer General Register B	TGRB	16	16	2, 3 PCLKB	2 ICLK	TPUa
0008 8140h	TPU3	Timer Control Register	TCR	8	8	2, 3 PCLKB	2 ICLK	TPUa
0008 8141h	TPU3	Timer Mode Register	TMDR	8	8	2, 3 PCLKB	2 ICLK	TPUa
0008 8142h	TPU3	Timer I/O Control Register H	TIORH	8	8	2, 3 PCLKB	2 ICLK	TPUa
0008 8143h	TPU3	Timer I/O Control Register L	TIORL	8	8	2, 3 PCLKB	2 ICLK	TPUa
0008 8144h	TPU3	Timer Interrupt Enable Register	TIER	8	8	2, 3 PCLKB	2 ICLK	TPUa
0008 8145h	TPU3	Timer Status Register	TSR	8	8	2, 3 PCLKB	2 ICLK	TPUa
0008 8146h	TPU3	Timer Counter	TCNT	16	16	2, 3 PCLKB	2 ICLK	TPUa
0008 8148h	TPU3	Timer General Register A	TGRA	16	16	2, 3 PCLKB	2 ICLK	TPUa
0008 814Ah	TPU3	Timer General Register B	TGRB	16	16	2, 3 PCLKB	2 ICLK	TPUa
0008 814Ch	TPU3	Timer General Register C	TGRC	16	16	2, 3 PCLKB	2 ICLK	TPUa
0008 814Eh	TPU3	Timer General Register D	TGRD	16	16	2, 3 PCLKB	2 ICLK	TPUa
0008 8150h	TPU4	Timer Control Register	TCR	8	8	2, 3 PCLKB	2 ICLK	TPUa
0008 8151h	TPU4	Timer Mode Register	TMDR	8	8	2, 3 PCLKB	2 ICLK	TPUa
0008 8152h	TPU4	Timer I/O Control Register	TIOR	8	8	2, 3 PCLKB	2 ICLK	TPUa
0008 8154h	TPU4	Timer Interrupt Enable Register	TIER	8	8	2, 3 PCLKB	2 ICLK	TPUa
0008 8155h	TPU4	Timer Status Register	TSR	8	8	2, 3 PCLKB	2 ICLK	TPUa
0008 8156h	TPU4	Timer Counter	TCNT	16	16	2, 3 PCLKB	2 ICLK	TPUa
0008 8158h	TPU4	Timer General Register A	TGRA	16	16	2, 3 PCLKB	2 ICLK	TPUa
0008 815Ah	TPU4	Timer General Register B	TGRB	16	16	2, 3 PCLKB	2 ICLK	TPUa
0008 8160h	TPU5	Timer Control Register	TCR	8	8	2, 3 PCLKB	2 ICLK	TPUa
0008 8161h	TPU5	Timer Mode Register	TMDR	8	8	2, 3 PCLKB	2 ICLK	TPUa
0008 8162h	TPU5	Timer I/O Control Register	TIOR	8	8	2, 3 PCLKB	2 ICLK	TPUa
0008 8164h	TPU5	Timer Interrupt Enable Register	TIER	8	8	2, 3 PCLKB	2 ICLK	TPUa
0008 8165h	TPU5	Timer Status Register	TSR	8	8	2, 3 PCLKB	2 ICLK	TPUa
0008 8166h	TPU5	Timer Counter	TCNT	16	16	2, 3 PCLKB	2 ICLK	TPUa
0008 8168h	TPU5	Timer General Register A	TGRA	16	16	2, 3 PCLKB	2 ICLK	TPUa
0008 816Ah	TPU5	Timer General Register B	TGRB	16	16	2, 3 PCLKB	2 ICLK	TPUa
0008 81E6h	PPG0	PPG Output Control Register	PCR	8	8	2, 3 PCLKB	2 ICLK	PPG
0008 81E7h	PPG0	PPG Output Mode Register	PMR	8	8	2, 3 PCLKB	2 ICLK	PPG
0008 81E8h	PPG0	Next Data Enable Registers H	NDERH	8	8	2, 3 PCLKB	2 ICLK	PPG
0008 81E9h	PPG0	Next Data Enable Registers L	NDERL	8	8	2, 3 PCLKB	2 ICLK	PPG
0008 81EAh	PPG0	Output Data Registers H	PODRH	8	8	2, 3 PCLKB	2 ICLK	PPG
0008 81EBh	PPG0	Output Data Registers L	PODRL	8	8	2, 3 PCLKB	2 ICLK	PPG
0008 81ECh	PPG0	Next Data Registers H*1	NDRH	8	8	2, 3 PCLKB	2 ICLK	PPG
0008 81EDh	PPG0	Next Data Registers L*2	NDRL	8	8	2, 3 PCLKB	2 ICLK	PPG
0008 81EEh	PPG0	Next Data Registers H*1	NDRH2	8	8	2, 3 PCLKB	2 ICLK	PPG
0008 81EFh	PPG0	Next Data Registers L*2	NDRL2	8	8	2, 3 PCLKB	2 ICLK	PPG
0008 81F0h	PPG1	PPG Trigger Select Register	PTRSLR	8	8	2, 3 PCLKB	2 ICLK	PPG
0008 81F6h	PPG1	PPG Output Control Register	PCR	8	8	2, 3 PCLKB	2 ICLK	PPG
0008 81F7h	PPG1	PPG Output Mode Register	PMR	8	8	2, 3 PCLKB	2 ICLK	PPG
0008 81F8h	PPG1	Next Data Enable Registers H	NDERH	8	8	2, 3 PCLKB	2 ICLK	PPG
0008 81F9h	PPG1	Next Data Enable Registers L	NDERL	8	8	2, 3 PCLKB	2 ICLK	PPG
0008 81FAh	PPG1	Output Data Registers H	PODRH	8	8	2, 3 PCLKB	2 ICLK	PPG
0008 81FBh	PPG1	Output Data Registers L	PODRL	8	8	2, 3 PCLKB	2 ICLK	PPG
0008 81FCh	PPG1	Next Data Registers H*3	NDRH	8	8	2, 3 PCLKB	2 ICLK	PPG
0008 81FDh	PPG1	Next Data Registers L*4	NDRL	8	8	2, 3 PCLKB	2 ICLK	PPG
0008 81FEh	PPG1	Next Data Registers H*3	NDRH2	8	8	2, 3 PCLKB	2 ICLK	PPG

Table 4.1 List of I/O Registers (Address Order) (16 / 70)

Address	Module Symbol	Register Name	Register Symbol	Number of Bits	Access Size	Number of Access Cycles		Related Function
						ICLK ≥ PCLK	ICLK < PCLK	
0008 81FFh	PPG1	Next Data Registers L*4	NDRL2	8	8	2, 3 PCLKB	2 ICLK	PPG
0008 8200h	TMR0	Timer Control Register	TCR	8	8	2, 3 PCLKB	2 ICLK	TMR
0008 8201h	TMR1	Timer Control Register	TCR	8	8	2, 3 PCLKB	2 ICLK	TMR
0008 8202h	TMR0	Timer Control/Status Register	TCSR	8	8	2, 3 PCLKB	2 ICLK	TMR
0008 8203h	TMR1	Timer Control/Status Register	TCSR	8	8	2, 3 PCLKB	2 ICLK	TMR
0008 8204h	TMR0	Time Constant Register A	TCORA	8	8	2, 3 PCLKB	2 ICLK	TMR
0008 8204h	TMR01	Time Constant Register A	TCORA	16	16	2, 3 PCLKB	2 ICLK	TMR
0008 8205h	TMR1	Time Constant Register A	TCORA	8	8	2, 3 PCLKB	2 ICLK	TMR
0008 8206h	TMR0	Time Constant Register B	TCORB	8	8	2, 3 PCLKB	2 ICLK	TMR
0008 8206h	TMR01	Time Constant Register B	TCORB	16	16	2, 3 PCLKB	2 ICLK	TMR
0008 8207h	TMR1	Time Constant Register B	TCORB	8	8	2, 3 PCLKB	2 ICLK	TMR
0008 8208h	TMR0	Timer Counter	TCNT	8	8	2, 3 PCLKB	2 ICLK	TMR
0008 8208h	TMR01	Timer Counter	TCNT	16	16	2, 3 PCLKB	2 ICLK	TMR
0008 8209h	TMR1	Timer Counter	TCNT	8	8	2, 3 PCLKB	2 ICLK	TMR
0008 820Ah	TMR0	Timer Counter Control Register	TCCR	8	8	2, 3 PCLKB	2 ICLK	TMR
0008 820Ah	TMR01	Timer Counter Control Register	TCCR	16	16	2, 3 PCLKB	2 ICLK	TMR
0008 820Bh	TMR1	Timer Counter Control Register	TCCR	8	8	2, 3 PCLKB	2 ICLK	TMR
0008 820Ch	TMR0	Timer Counter Start Register	TCSTR	8	8	2, 3 PCLKB	2 ICLK	TMR
0008 820Dh	TMR1	Timer Counter Start Register	TCSTR	8	8	2, 3 PCLKB	2 ICLK	TMR
0008 8210h	TMR2	Timer Control Register	TCR	8	8	2, 3 PCLKB	2 ICLK	TMR
0008 8211h	TMR3	Timer Control Register	TCR	8	8	2, 3 PCLKB	2 ICLK	TMR
0008 8212h	TMR2	Timer Control/Status Register	TCSR	8	8	2, 3 PCLKB	2 ICLK	TMR
0008 8213h	TMR3	Timer Control/Status Register	TCSR	8	8	2, 3 PCLKB	2 ICLK	TMR
0008 8214h	TMR2	Time Constant Register A	TCORA	8	8	2, 3 PCLKB	2 ICLK	TMR
0008 8214h	TMR23	Time Constant Register A	TCORA	16	16	2, 3 PCLKB	2 ICLK	TMR
0008 8215h	TMR3	Time Constant Register A	TCORA	8	8	2, 3 PCLKB	2 ICLK	TMR
0008 8216h	TMR2	Time Constant Register B	TCORB	8	8	2, 3 PCLKB	2 ICLK	TMR
0008 8216h	TMR23	Time Constant Register B	TCORB	16	16	2, 3 PCLKB	2 ICLK	TMR
0008 8217h	TMR3	Time Constant Register B	TCORB	8	8	2, 3 PCLKB	2 ICLK	TMR
0008 8218h	TMR2	Timer Counter	TCNT	8	8	2, 3 PCLKB	2 ICLK	TMR
0008 8218h	TMR23	Timer Counter	TCNT	16	16	2, 3 PCLKB	2 ICLK	TMR
0008 8219h	TMR3	Timer Counter	TCNT	8	8	2, 3 PCLKB	2 ICLK	TMR
0008 821Ah	TMR2	Timer Counter Control Register	TCCR	8	8	2, 3 PCLKB	2 ICLK	TMR
0008 821Ah	TMR23	Timer Counter Control Register	TCCR	16	16	2, 3 PCLKB	2 ICLK	TMR
0008 821Bh	TMR3	Timer Counter Control Register	TCCR	8	8	2, 3 PCLKB	2 ICLK	TMR
0008 821Ch	TMR2	Timer Counter Start Register	TCSTR	8	8	2, 3 PCLKB	2 ICLK	TMR
0008 821Dh	TMR3	Timer Counter Start Register	TCSTR	8	8	2, 3 PCLKB	2 ICLK	TMR
0008 8280h	CRC	CRC Control Register	CRCCR	8	8	2, 3 PCLKB	2 ICLK	CRC
0008 8281h	CRC	CRC Data Input Register	CRCDIR	8	8	2, 3 PCLKB	2 ICLK	CRC
0008 8282h	CRC	CRC Data Output Register	CRCDOR	16	16	2, 3 PCLKB	2 ICLK	CRC
0008 8300h	RIIC0	I ² C-bus Control Register 1	ICCR1	8	8	2, 3 PCLKB	2 ICLK	RIICa
0008 8301h	RIIC0	I ² C-bus Control Register 2	ICCR2	8	8	2, 3 PCLKB	2 ICLK	RIICa
0008 8302h	RIIC0	I ² C-bus Mode Register 1	ICMR1	8	8	2, 3 PCLKB	2 ICLK	RIICa
0008 8303h	RIIC0	I ² C-bus Mode Register 2	ICMR2	8	8	2, 3 PCLKB	2 ICLK	RIICa
0008 8304h	RIIC0	I ² C-bus Mode Register 3	ICMR3	8	8	2, 3 PCLKB	2 ICLK	RIICa
0008 8305h	RIIC0	I ² C-bus Function Enable Register	ICFER	8	8	2, 3 PCLKB	2 ICLK	RIICa
0008 8306h	RIIC0	I ² C-bus Status Enable Register	ICSER	8	8	2, 3 PCLKB	2 ICLK	RIICa
0008 8307h	RIIC0	I ² C-bus Interrupt Enable Register	ICIER	8	8	2, 3 PCLKB	2 ICLK	RIICa
0008 8308h	RIIC0	I ² C-bus Status Register 1	ICSR1	8	8	2, 3 PCLKB	2 ICLK	RIICa
0008 8309h	RIIC0	I ² C-bus Status Register 2	ICSR2	8	8	2, 3 PCLKB	2 ICLK	RIICa

Table 4.1 List of I/O Registers (Address Order) (17 / 70)

Address	Module Symbol	Register Name	Register Symbol	Number of Bits	Access Size	Number of Access Cycles		Related Function
						ICLK ≥ PCLK	ICLK < PCLK	
0008 830Ah	RIIC0	Slave Address Register L0	SARL0	8	8	2, 3 PCLKB	2 ICLK	RIICa
0008 830Bh	RIIC0	Slave Address Register U0	SARU0	8	8	2, 3 PCLKB	2 ICLK	RIICa
0008 830Ch	RIIC0	Slave Address Register L1	SARL1	8	8	2, 3 PCLKB	2 ICLK	RIICa
0008 830Dh	RIIC0	Slave Address Register U1	SARU1	8	8	2, 3 PCLKB	2 ICLK	RIICa
0008 830Eh	RIIC0	Slave Address Register L2	SARL2	8	8	2, 3 PCLKB	2 ICLK	RIICa
0008 830Fh	RIIC0	Slave Address Register U2	SARU2	8	8	2, 3 PCLKB	2 ICLK	RIICa
0008 8310h	RIIC0	I ² C-bus Bit Rate Low-Level Register	ICBRL	8	8	2, 3 PCLKB	2 ICLK	RIICa
0008 8311h	RIIC0	I ² C-bus Bit Rate High-Level Register	ICBRH	8	8	2, 3 PCLKB	2 ICLK	RIICa
0008 8312h	RIIC0	I ² C-bus Transmit Data Register	ICDRT	8	8	2, 3 PCLKB	2 ICLK	RIICa
0008 8313h	RIIC0	I ² C-bus Receive Data Register	ICDRR	8	8	2, 3 PCLKB	2 ICLK	RIICa
0008 8340h	RIIC2	I ² C-bus Control Register 1	ICCR1	8	8	2, 3 PCLKB	2 ICLK	RIICa
0008 8341h	RIIC2	I ² C-bus Control Register 2	ICCR2	8	8	2, 3 PCLKB	2 ICLK	RIICa
0008 8342h	RIIC2	I ² C-bus Mode Register 1	ICMR1	8	8	2, 3 PCLKB	2 ICLK	RIICa
0008 8343h	RIIC2	I ² C-bus Mode Register 2	ICMR2	8	8	2, 3 PCLKB	2 ICLK	RIICa
0008 8344h	RIIC2	I ² C-bus Mode Register 3	ICMR3	8	8	2, 3 PCLKB	2 ICLK	RIICa
0008 8345h	RIIC2	I ² C-bus Function Enable Register	ICFER	8	8	2, 3 PCLKB	2 ICLK	RIICa
0008 8346h	RIIC2	I ² C-bus Status Enable Register	ICSER	8	8	2, 3 PCLKB	2 ICLK	RIICa
0008 8347h	RIIC2	I ² C-bus Interrupt Enable Register	ICIER	8	8	2, 3 PCLKB	2 ICLK	RIICa
0008 8348h	RIIC2	I ² C-bus Status Register 1	ICSR1	8	8	2, 3 PCLKB	2 ICLK	RIICa
0008 8349h	RIIC2	I ² C-bus Status Register 2	ICSR2	8	8	2, 3 PCLKB	2 ICLK	RIICa
0008 834Ah	RIIC2	Slave Address Register L0	SARL0	8	8	2, 3 PCLKB	2 ICLK	RIICa
0008 834Bh	RIIC2	Slave Address Register U0	SARU0	8	8	2, 3 PCLKB	2 ICLK	RIICa
0008 834Ch	RIIC2	Slave Address Register L1	SARL1	8	8	2, 3 PCLKB	2 ICLK	RIICa
0008 834Dh	RIIC2	Slave Address Register U1	SARU1	8	8	2, 3 PCLKB	2 ICLK	RIICa
0008 834Eh	RIIC2	Slave Address Register L2	SARL2	8	8	2, 3 PCLKB	2 ICLK	RIICa
0008 834Fh	RIIC2	Slave Address Register U2	SARU2	8	8	2, 3 PCLKB	2 ICLK	RIICa
0008 8350h	RIIC2	I ² C-bus Bit Rate Low-Level Register	ICBRL	8	8	2, 3 PCLKB	2 ICLK	RIICa
0008 8351h	RIIC2	I ² C-bus Bit Rate High-Level Register	ICBRH	8	8	2, 3 PCLKB	2 ICLK	RIICa
0008 8352h	RIIC2	I ² C-bus Transmit Data Register	ICDRT	8	8	2, 3 PCLKB	2 ICLK	RIICa
0008 8353h	RIIC2	I ² C-bus Receive Data Register	ICDRR	8	8	2, 3 PCLKB	2 ICLK	RIICa
0008 8500h	MMCIF	Command Setting Register	CECMDSET	32	32	2, 3 PCLKB	2 ICLK	MMCIF
0008 8508h	MMCIF	Argument Register	CEARG	32	32	2, 3 PCLKB	2 ICLK	MMCIF
0008 850Ch	MMCIF	Automatically Issued CMD12 Argument Register	CEARGCMD12	32	32	2, 3 PCLKB	2 ICLK	MMCIF
0008 8510h	MMCIF	Command Control Register	CECMDCTRL	32	32	2, 3 PCLKB	2 ICLK	MMCIF
0008 8514h	MMCIF	Transfer Block Setting Register	CEBLOCKSET	32	32	2, 3 PCLKB	2 ICLK	MMCIF
0008 8518h	MMCIF	Clock Control Register	CECLKCTRL	32	32	2, 3 PCLKB	2 ICLK	MMCIF
0008 851Ch	MMCIF	Buffer Access Setting Register	CEBUFACC	32	32	2, 3 PCLKB	2 ICLK	MMCIF
0008 8520h	MMCIF	Response Register 3	CERESP3	32	32	2, 3 PCLKB	2 ICLK	MMCIF
0008 8524h	MMCIF	Response Register 2	CERESP2	32	32	2, 3 PCLKB	2 ICLK	MMCIF
0008 8528h	MMCIF	Response Register 1	CERESP1	32	32	2, 3 PCLKB	2 ICLK	MMCIF
0008 852Ch	MMCIF	Response Register 0	CERESP0	32	32	2, 3 PCLKB	2 ICLK	MMCIF
0008 8530h	MMCIF	Automatically Issued CMD12 Response Register	CERESPCMD12	32	32	2, 3 PCLKB	2 ICLK	MMCIF
0008 8534h	MMCIF	Data Register	CEDATA	32	32	2, 3 PCLKB	2 ICLK	MMCIF
0008 853Ch	MMCIF	Boot Operation Setting Register	CEBOOT	32	32	2, 3 PCLKB	2 ICLK	MMCIF
0008 8540h	MMCIF	Interrupt status Flag Register	CEINT	32	32	2, 3 PCLKB	2 ICLK	MMCIF
0008 8544h	MMCIF	Interrupt request Enable Register	CEINTEN	32	32	2, 3 PCLKB	2 ICLK	MMCIF
0008 8548h	MMCIF	Status Register 1	CEHOSTSTS1	32	32	2, 3 PCLKB	2 ICLK	MMCIF

Table 4.1 List of I/O Registers (Address Order) (18 / 70)

Address	Module Symbol	Register Name	Register Symbol	Number of Bits	Access Size	Number of Access Cycles		Related Function
						ICLK ≥ PCLK	ICLK < PCLK	
0008 854Ch	MMCIF	Status Register 2	CEHOSTSTS2	32	32	2, 3 PCLKB	2 ICLK	MMCIF
0008 8570h	MMCIF	MMC Detection and Port Control Register	CEDETECT	32	32	2, 3 PCLKB	2 ICLK	MMCIF
0008 8574h	MMCIF	Special Mode Setting Register	CEADDMODE	32	32	2, 3 PCLKB	2 ICLK	MMCIF
0008 857Ch	MMCIF	Version Register	CEVERSION	32	32	2, 3 PCLKB	2 ICLK	MMCIF
0008 9000h	S12AD	A/D Control Register	ADCSR	16	16	2, 3 PCLKB	2 ICLK	S12ADC
0008 9004h	S12AD	A/D Channel Select Register A0	ADANSA0	16	16	2, 3 PCLKB	2 ICLK	S12ADC
0008 9008h	S12AD	A/D-Converted Value Addition/Average Mode Select Register 0	ADADS0	16	16	2, 3 PCLKB	2 ICLK	S12ADC
0008 900Ch	S12AD	A/D-Converted Value Addition/Average Count Select Register	ADADC	8	8	2, 3 PCLKB	2 ICLK	S12ADC
0008 900Eh	S12AD	A/D Control Extended Register	ADCER	16	16	2, 3 PCLKB	2 ICLK	S12ADC
0008 9010h	S12AD	A/D Start Trigger Select Register	ADSTRGR	16	16	2, 3 PCLKB	2 ICLK	S12ADC
0008 9014h	S12AD	A/D Channel Select Register B0	ADANSB0	16	16	2, 3 PCLKB	2 ICLK	S12ADC
0008 9018h	S12AD	A/D Data Duplication Register	ADDBLDR	16	16	2, 3 PCLKB	2 ICLK	S12ADC
0008 901Eh	S12AD	A/D Self-Diagnosis Data Register	ADRD	16	16	2, 3 PCLKB	2 ICLK	S12ADC
0008 9020h	S12AD	A/D Data Register 0	ADDR0	16	16	2, 3 PCLKB	2 ICLK	S12ADC
0008 9022h	S12AD	A/D Data Register 1	ADDR1	16	16	2, 3 PCLKB	2 ICLK	S12ADC
0008 9024h	S12AD	A/D Data Register 2	ADDR2	16	16	2, 3 PCLKB	2 ICLK	S12ADC
0008 9026h	S12AD	A/D Data Register 3	ADDR3	16	16	2, 3 PCLKB	2 ICLK	S12ADC
0008 9028h	S12AD	A/D Data Register 4	ADDR4	16	16	2, 3 PCLKB	2 ICLK	S12ADC
0008 902Ah	S12AD	A/D Data Register 5	ADDR5	16	16	2, 3 PCLKB	2 ICLK	S12ADC
0008 902Ch	S12AD	A/D Data Register 6	ADDR6	16	16	2, 3 PCLKB	2 ICLK	S12ADC
0008 902Eh	S12AD	A/D Data Register 7	ADDR7	16	16	2, 3 PCLKB	2 ICLK	S12ADC
0008 9060h	S12AD	A/D Sampling State Register 0	ADSSTR0	8	8	2, 3 PCLKB	2 ICLK	S12ADC
0008 9066h	S12AD	A/D Sample-and-Hold Circuit Control Register	ADSHCR	16	16	2, 3 PCLKB	2 ICLK	S12ADC
0008 9073h	S12AD	A/D Sampling State Register 1	ADSSTR1	8	8	2, 3 PCLKB	2 ICLK	S12ADC
0008 9074h	S12AD	A/D Sampling State Register 2	ADSSTR2	8	8	2, 3 PCLKB	2 ICLK	S12ADC
0008 9075h	S12AD	A/D Sampling State Register 3	ADSSTR3	8	8	2, 3 PCLKB	2 ICLK	S12ADC
0008 9076h	S12AD	A/D Sampling State Register 4	ADSSTR4	8	8	2, 3 PCLKB	2 ICLK	S12ADC
0008 9077h	S12AD	A/D Sampling State Register 5	ADSSTR5	8	8	2, 3 PCLKB	2 ICLK	S12ADC
0008 9078h	S12AD	A/D Sampling State Register 6	ADSSTR6	8	8	2, 3 PCLKB	2 ICLK	S12ADC
0008 9079h	S12AD	A/D Sampling State Register 7	ADSSTR7	8	8	2, 3 PCLKB	2 ICLK	S12ADC
0008 907Ah	S12AD	A/D Disconnection Detection Control Register	ADDISCR	8	8	2, 3 PCLKB	2 ICLK	S12ADC
0008 907Ch	S12AD	A/D Sample-and-Hold Operating Mode Select Register	ADSHMSR	8	8	2, 3 PCLKB	2 ICLK	S12ADC

Table 4.1 List of I/O Registers (Address Order) (19 / 70)

Address	Module Symbol	Register Name	Register Symbol	Number of Bits	Access Size	Number of Access Cycles		Related Function
						ICLK ≥ PCLK	ICLK < PCLK	
0008 9080h	S12AD	A/D Group Scan Priority Control Register	ADGSPCR	16	16	2, 3 PCLKB	2 ICLK	S12ADC
0008 9084h	S12AD	A/D Data Duplication Register A	ADDBLDRA	16	16	2, 3 PCLKB	2 ICLK	S12ADC
0008 9086h	S12AD	A/D Data Duplication Register B	ADDBLDRB	16	16	2, 3 PCLKB	2 ICLK	S12ADC
0008 9090h	S12AD	A/D Compare Control Register	ADCMPCR	8	8	2, 3 PCLKB	2 ICLK	S12ADC
0008 9094h	S12AD	A/D Compare Channel Select Register 0	ADCMPSR0	16	16	2, 3 PCLKB	2 ICLK	S12ADC
0008 9098h	S12AD	A/D Compare Level Register 0	ADCMPLR0	16	16	2, 3 PCLKB	2 ICLK	S12ADC
0008 909Ch	S12AD	A/D Compare Data Register 0	ADCMPCR0	16	16	2, 3 PCLKB	2 ICLK	S12ADC
0008 909Eh	S12AD	A/D Compare Data Register 1	ADCMPCR1	16	16	2, 3 PCLKB	2 ICLK	S12ADC
0008 90A0h	S12AD	A/D Compare Status Register 0	ADCMPSR0	16	16	2, 3 PCLKB	2 ICLK	S12ADC
0008 9100h	S12AD1	A/D Control Register	ADCSR	16	16	2, 3 PCLKB	2 ICLK	S12ADC
0008 9104h	S12AD1	A/D Channel Select Register A0	ADANSA0	16	16	2, 3 PCLKB	2 ICLK	S12ADC
0008 9106h	S12AD1	A/D Channel Select Register A1	ADANSA1	16	16	2, 3 PCLKB	2 ICLK	S12ADC
0008 9108h	S12AD1	A/D-Converted Value Addition/Average Mode Select Register 0	ADADS0	16	16	2, 3 PCLKB	2 ICLK	S12ADC
0008 910Ah	S12AD1	A/D-Converted Value Addition/Average Mode Select Register 1	ADADS1	16	16	2, 3 PCLKB	2 ICLK	S12ADC
0008 910Ch	S12AD1	A/D-Converted Value Addition/Average Count Select Register	ADADC	8	8	2, 3 PCLKB	2 ICLK	S12ADC
0008 910Eh	S12AD1	A/D Control Extended Register	ADCER	16	16	2, 3 PCLKB	2 ICLK	S12ADC
0008 9110h	S12AD1	A/D Start Trigger Select Register	ADSTRGR	16	16	2, 3 PCLKB	2 ICLK	S12ADC
0008 9112h	S12AD1	A/D Conversion Extended Input Control Register	ADEXICR	16	16	2, 3 PCLKB	2 ICLK	S12ADC
0008 9114h	S12AD1	A/D Channel Select Register B0	ADANSB0	16	16	2, 3 PCLKB	2 ICLK	S12ADC
0008 9116h	S12AD1	A/D Channel Select Register B1	ADANSB1	16	16	2, 3 PCLKB	2 ICLK	S12ADC
0008 9118h	S12AD1	A/D Data Duplication Register	ADDBLDR	16	16	2, 3 PCLKB	2 ICLK	S12ADC
0008 911Ah	S12AD1	A/D Temperature Sensor Data Register	ADTSDR	16	16	2, 3 PCLKB	2 ICLK	S12ADC
0008 911Ch	S12AD1	A/D Internal Reference Voltage Data Register	ADOCDR	16	16	2, 3 PCLKB	2 ICLK	S12ADC
0008 911Eh	S12AD1	A/D Self-Diagnosis Data Register	ADRD	16	16	2, 3 PCLKB	2 ICLK	S12ADC
0008 9120h	S12AD1	A/D Data Register 0	ADDR0	16	16	2, 3 PCLKB	2 ICLK	S12ADC
0008 9122h	S12AD1	A/D Data Register 1	ADDR1	16	16	2, 3 PCLKB	2 ICLK	S12ADC
0008 9124h	S12AD1	A/D Data Register 2	ADDR2	16	16	2, 3 PCLKB	2 ICLK	S12ADC
0008 9126h	S12AD1	A/D Data Register 3	ADDR3	16	16	2, 3 PCLKB	2 ICLK	S12ADC
0008 9128h	S12AD1	A/D Data Register 4	ADDR4	16	16	2, 3 PCLKB	2 ICLK	S12ADC
0008 912Ah	S12AD1	A/D Data Register 5	ADDR5	16	16	2, 3 PCLKB	2 ICLK	S12ADC
0008 912Ch	S12AD1	A/D Data Register 6	ADDR6	16	16	2, 3 PCLKB	2 ICLK	S12ADC

Table 4.1 List of I/O Registers (Address Order) (20 / 70)

Address	Module Symbol	Register Name	Register Symbol	Number of Bits	Access Size	Number of Access Cycles		Related Function
						ICLK ≥ PCLK	ICLK < PCLK	
0008 912Eh	S12AD1	A/D Data Register 7	ADDR7	16	16	2, 3 PCLKB	2 ICLK	S12ADC
0008 9130h	S12AD1	A/D Data Register 8	ADDR8	16	16	2, 3 PCLKB	2 ICLK	S12ADC
0008 9132h	S12AD1	A/D Data Register 9	ADDR9	16	16	2, 3 PCLKB	2 ICLK	S12ADC
0008 9134h	S12AD1	A/D Data Register 10	ADDR10	16	16	2, 3 PCLKB	2 ICLK	S12ADC
0008 9136h	S12AD1	A/D Data Register 11	ADDR11	16	16	2, 3 PCLKB	2 ICLK	S12ADC
0008 9138h	S12AD1	A/D Data Register 12	ADDR12	16	16	2, 3 PCLKB	2 ICLK	S12ADC
0008 913Ah	S12AD1	A/D Data Register 13	ADDR13	16	16	2, 3 PCLKB	2 ICLK	S12ADC
0008 913Ch	S12AD1	A/D Data Register 14	ADDR14	16	16	2, 3 PCLKB	2 ICLK	S12ADC
0008 913Eh	S12AD1	A/D Data Register 15	ADDR15	16	16	2, 3 PCLKB	2 ICLK	S12ADC
0008 9140h	S12AD1	A/D Data Register 16	ADDR16	16	16	2, 3 PCLKB	2 ICLK	S12ADC
0008 9142h	S12AD1	A/D Data Register 17	ADDR17	16	16	2, 3 PCLKB	2 ICLK	S12ADC
0008 9144h	S12AD1	A/D Data Register 18	ADDR18	16	16	2, 3 PCLKB	2 ICLK	S12ADC
0008 9146h	S12AD1	A/D Data Register 19	ADDR19	16	16	2, 3 PCLKB	2 ICLK	S12ADC
0008 9148h	S12AD1	A/D Data Register 20	ADDR20	16	16	2, 3 PCLKB	2 ICLK	S12ADC
0008 9160h	S12AD1	A/D Sampling State Register 0	ADSSTR0	8	8	2, 3 PCLKB	2 ICLK	S12ADC
0008 9161h	S12AD1	A/D Sampling State Register L	ADSSTRL	8	8	2, 3 PCLKB	2 ICLK	S12ADC
0008 9170h	S12AD1	A/D Sampling State Register T	ADSSTRT	8	8	2, 3 PCLKB	2 ICLK	S12ADC
0008 9171h	S12AD1	A/D Sampling State Register O	ADSSTRO	8	8	2, 3 PCLKB	2 ICLK	S12ADC
0008 9173h	S12AD1	A/D Sampling State Register 1	ADSSTR1	8	8	2, 3 PCLKB	2 ICLK	S12ADC
0008 9174h	S12AD1	A/D Sampling State Register 2	ADSSTR2	8	8	2, 3 PCLKB	2 ICLK	S12ADC
0008 9175h	S12AD1	A/D Sampling State Register 3	ADSSTR3	8	8	2, 3 PCLKB	2 ICLK	S12ADC
0008 9176h	S12AD1	A/D Sampling State Register 4	ADSSTR4	8	8	2, 3 PCLKB	2 ICLK	S12ADC
0008 9177h	S12AD1	A/D Sampling State Register 5	ADSSTR5	8	8	2, 3 PCLKB	2 ICLK	S12ADC
0008 9178h	S12AD1	A/D Sampling State Register 6	ADSSTR6	8	8	2, 3 PCLKB	2 ICLK	S12ADC
0008 9179h	S12AD1	A/D Sampling State Register 7	ADSSTR7	8	8	2, 3 PCLKB	2 ICLK	S12ADC
0008 917Ah	S12AD1	A/D Disconnection Detection Control Register	ADDISCR	8	8	2, 3 PCLKB	2 ICLK	S12ADC
0008 9180h	S12AD1	A/D Group Scan Priority Control Register	ADGSPCR	16	16	2, 3 PCLKB	2 ICLK	S12ADC
0008 9184h	S12AD1	A/D Data Duplication Register A	ADDBLDRA	16	16	2, 3 PCLKB	2 ICLK	S12ADC
0008 9186h	S12AD1	A/D Data Duplication Register B	ADDBLDRB	16	16	2, 3 PCLKB	2 ICLK	S12ADC
0008 9190h	S12AD1	A/D Compare Control Register	ADCMPCR	8	8	2, 3 PCLKB	2 ICLK	S12ADC
0008 9192h	S12AD1	A/D Compare Channel Select Extended Register	ADCMPANSE R	8	8	2, 3 PCLKB	2 ICLK	S12ADC

Table 4.1 List of I/O Registers (Address Order) (21 / 70)

Address	Module Symbol	Register Name	Register Symbol	Number of Bits	Access Size	Number of Access Cycles		Related Function
						ICLK ≥ PCLK	ICLK < PCLK	
0008 9193h	S12AD1	A/D Compare Level Extended Register	ADCMPLER	8	8	2, 3 PCLKB	2 ICLK	S12ADC
0008 9194h	S12AD1	A/D Compare Channel Select Register 0	ADCMPSR0	16	16	2, 3 PCLKB	2 ICLK	S12ADC
0008 9196h	S12AD1	A/D Compare Channel Select Register 1	ADCMPSR1	16	16	2, 3 PCLKB	2 ICLK	S12ADC
0008 9198h	S12AD1	A/D Compare Level Register 0	ADCMPLR0	16	16	2, 3 PCLKB	2 ICLK	S12ADC
0008 919Ah	S12AD1	A/D Compare Level Register 1	ADCMPLR1	16	16	2, 3 PCLKB	2 ICLK	S12ADC
0008 919Ch	S12AD1	A/D Compare Data Register 0	ADCMPCR0	16	16	2, 3 PCLKB	2 ICLK	S12ADC
0008 919Eh	S12AD1	A/D Compare Data Register 1	ADCMPCR1	16	16	2, 3 PCLKB	2 ICLK	S12ADC
0008 91A0h	S12AD1	A/D Compare Status Register 0	ADCMPSR0	16	16	2, 3 PCLKB	2 ICLK	S12ADC
0008 91A2h	S12AD1	A/D Compare Status Register 1	ADCMPSR1	16	16	2, 3 PCLKB	2 ICLK	S12ADC
0008 91A4h	S12AD1	A/D Compare Status Extended Register	ADCMPSER	8	8	2, 3 PCLKB	2 ICLK	S12ADC
0008 9E00h	QSPI	QSPI Control Register	SPCR	8	8	4, 5 PCLKB	2, 3 ICLK	QSPI
0008 9E01h	QSPI	QSPI Slave Select Polarity Register	SSLP	8	8	4, 5 PCLKB	2, 3 ICLK	QSPI
0008 9E02h	QSPI	QSPI Pin Control Register	SPPCR	8	8	4, 5 PCLKB	2, 3 ICLK	QSPI
0008 9E03h	QSPI	QSPI Status Register	SPSR	8	8	4, 5 PCLKB	2, 3 ICLK	QSPI
0008 9E04h	QSPI	QSPI Data Register	SPDR	32	8, 16, 32	4, 5 PCLKB	2, 3 ICLK	QSPI
0008 9E08h	QSPI	QSPI Sequence Control Register	SPSCR	8	8	4, 5 PCLKB	2, 3 ICLK	QSPI
0008 9E09h	QSPI	QSPI Sequence Status Register	SPSSR	8	8	4, 5 PCLKB	2, 3 ICLK	QSPI
0008 9E0Ah	QSPI	QSPI Bit Rate Register	SPBR	8	8	4, 5 PCLKB	2, 3 ICLK	QSPI
0008 9E0Bh	QSPI	QSPI Data Control Register	SPDCR	8	8	4, 5 PCLKB	2, 3 ICLK	QSPI
0008 9E0Ch	QSPI	QSPI Clock Delay Register	SPCKD	8	8	4, 5 PCLKB	2, 3 ICLK	QSPI
0008 9E0Dh	QSPI	QSPI Slave Select Negation Delay Register	SSLND	8	8	4, 5 PCLKB	2, 3 ICLK	QSPI
0008 9E0Eh	QSPI	QSPI Next-Access Delay Register	SPND	8	8	4, 5 PCLKB	2, 3 ICLK	QSPI
0008 9E10h	QSPI	QSPI Command Register 0	SPCMD0	16	16	4, 5 PCLKB	2, 3 ICLK	QSPI
0008 9E12h	QSPI	QSPI Command Register 1	SPCMD1	16	16	4, 5 PCLKB	2, 3 ICLK	QSPI
0008 9E14h	QSPI	QSPI Command Register 2	SPCMD2	16	16	4, 5 PCLKB	2, 3 ICLK	QSPI
0008 9E16h	QSPI	QSPI Command Register 3	SPCMD3	16	16	4, 5 PCLKB	2, 3 ICLK	QSPI
0008 9E18h	QSPI	QSPI Buffer Control Register	SPBFCR	8	8	4, 5 PCLKB	2, 3 ICLK	QSPI
0008 9E1Ah	QSPI	QSPI Buffer Data Count Set Register	SPBDCR	16	16	4, 5 PCLKB	2, 3 ICLK	QSPI
0008 9E1Ch	QSPI	QSPI Transfer Data Length Multiplier Setting Register 0	SPBMUL0	32	32	4, 5 PCLKB	2, 3 ICLK	QSPI
0008 9E20h	QSPI	QSPI Transfer Data Length Multiplier Setting Register 1	SPBMUL1	32	32	4, 5 PCLKB	2, 3 ICLK	QSPI
0008 9E24h	QSPI	QSPI Transfer Data Length Multiplier Setting Register 2	SPBMUL2	32	32	4, 5 PCLKB	2, 3 ICLK	QSPI
0008 9E28h	QSPI	QSPI Transfer Data Length Multiplier Setting Register 3	SPBMUL3	32	32	4, 5 PCLKB	2, 3 ICLK	QSPI
0008 A000h	SCIO	Serial Mode Register	SMR	8	8	2, 3 PCLKB	2 ICLK	SClg, SClh
0008 A001h	SCIO	Bit Rate Register	BRR	8	8	2, 3 PCLKB	2 ICLK	SClg, SClh
0008 A002h	SCIO	Serial Control Register	SCR	8	8	2, 3 PCLKB	2 ICLK	SClg, SClh
0008 A003h	SCIO	Transmit Data Register	TDR	8	8	2, 3 PCLKB	2 ICLK	SClg, SClh
0008 A004h	SCIO	Serial Status Register	SSR	8	8	2, 3 PCLKB	2 ICLK	SClg, SClh
0008 A005h	SCIO	Receive Data Register	RDR	8	8	2, 3 PCLKB	2 ICLK	SClg, SClh

Table 4.1 List of I/O Registers (Address Order) (22 / 70)

Address	Module Symbol	Register Name	Register Symbol	Number of Bits	Access Size	Number of Access Cycles		Related Function
						ICLK ≥ PCLK	ICLK < PCLK	
0008 A006h	SMCI0	Smart Card Mode Register	SCMR	8	8	2, 3 PCLKB	2 ICLK	SClg, SClh
0008 A007h	SCIO	Serial Extended Mode Register	SEMR	8	8	2, 3 PCLKB	2 ICLK	SClg, SClh
0008 A008h	SCIO	Noise Filter Setting Register	SNFR	8	8	2, 3 PCLKB	2 ICLK	SClg, SClh
0008 A009h	SCIO	I ² C Mode Register 1	SIMR1	8	8	2, 3 PCLKB	2 ICLK	SClg, SClh
0008 A00Ah	SCIO	I ² C Mode Register 2	SIMR2	8	8	2, 3 PCLKB	2 ICLK	SClg, SClh
0008 A00Bh	SCIO	I ² C Mode Register 3	SIMR3	8	8	2, 3 PCLKB	2 ICLK	SClg, SClh
0008 A00Ch	SCIO	I ² C Status Register	SISR	8	8	2, 3 PCLKB	2 ICLK	SClg, SClh
0008 A00Dh	SCIO	SPI Mode Register	SPMR	8	8	2, 3 PCLKB	2 ICLK	SClg, SClh
0008 A00Eh	SCIO	Transmit Data Register H	TDRH	8	8	2, 3 PCLKB	2 ICLK	SClg, SClh
0008 A00Fh	SCIO	Transmit Data Register L	TDRL	8	8	2, 3 PCLKB	2 ICLK	SClg, SClh
0008 A00Eh	SCIO	Transmit Data Register HL	TDRHL	16	16	4, 5 PCLKB	2 ICLK	SClg, SClh
0008 A010h	SCIO	Receive Data Register H	RDRH	8	8	2, 3 PCLKB	2 ICLK	SClg, SClh
0008 A011h	SCIO	Receive Data Register L	RDRL	8	8	2, 3 PCLKB	2 ICLK	SClg, SClh
0008 A010h	SCIO	Receive Data Register HL	RDRHL	16	16	4, 5 PCLKB	2 ICLK	SClg, SClh
0008 A012h	SCIO	Modulation Duty Register	MDDR	8	8	2, 3 PCLKB	2 ICLK	SClg, SClh
0008 A020h	SCI1	Serial Mode Register	SMR	8	8	2, 3 PCLKB	2 ICLK	SClg, SClh
0008 A021h	SCI1	Bit Rate Register	BRR	8	8	2, 3 PCLKB	2 ICLK	SClg, SClh
0008 A022h	SCI1	Serial Control Register	SCR	8	8	2, 3 PCLKB	2 ICLK	SClg, SClh
0008 A023h	SCI1	Transmit Data Register	TDR	8	8	2, 3 PCLKB	2 ICLK	SClg, SClh
0008 A024h	SCI1	Serial Status Register	SSR	8	8	2, 3 PCLKB	2 ICLK	SClg, SClh
0008 A025h	SCI1	Receive Data Register	RDR	8	8	2, 3 PCLKB	2 ICLK	SClg, SClh
0008 A026h	SMCI1	Smart Card Mode Register	SCMR	8	8	2, 3 PCLKB	2 ICLK	SClg, SClh
0008 A027h	SCI1	Serial Extended Mode Register	SEMR	8	8	2, 3 PCLKB	2 ICLK	SClg, SClh
0008 A028h	SCI1	Noise Filter Setting Register	SNFR	8	8	2, 3 PCLKB	2 ICLK	SClg, SClh
0008 A029h	SCI1	I ² C Mode Register 1	SIMR1	8	8	2, 3 PCLKB	2 ICLK	SClg, SClh
0008 A02Ah	SCI1	I ² C Mode Register 2	SIMR2	8	8	2, 3 PCLKB	2 ICLK	SClg, SClh
0008 A02Bh	SCI1	I ² C Mode Register 3	SIMR3	8	8	2, 3 PCLKB	2 ICLK	SClg, SClh
0008 A02Ch	SCI1	I ² C Status Register	SISR	8	8	2, 3 PCLKB	2 ICLK	SClg, SClh
0008 A02Dh	SCI1	SPI Mode Register	SPMR	8	8	2, 3 PCLKB	2 ICLK	SClg, SClh
0008 A02Eh	SCI1	Transmit Data Register H	TDRH	8	8	2, 3 PCLKB	2 ICLK	SClg, SClh
0008 A02Fh	SCI1	Transmit Data Register L	TDRL	8	8	2, 3 PCLKB	2 ICLK	SClg, SClh

Table 4.1 List of I/O Registers (Address Order) (23 / 70)

Address	Module Symbol	Register Name	Register Symbol	Number of Bits	Access Size	Number of Access Cycles		Related Function
						ICLK ≥ PCLK	ICLK < PCLK	
0008 A02Eh	SCI1	Transmit Data Register HL	TDRHL	16	16	4, 5 PCLKB	2 ICLK	SClg, SClh
0008 A030h	SCI1	Receive Data Register H	RDRH	8	8	2, 3 PCLKB	2 ICLK	SClg, SClh
0008 A031h	SCI1	Receive Data Register L	RDRL	8	8	2, 3 PCLKB	2 ICLK	SClg, SClh
0008 A030h	SCI1	Receive Data Register HL	RDRHL	16	16	4, 5 PCLKB	2 ICLK	SClg, SClh
0008 A032h	SCI1	Modulation Duty Register	MDDR	8	8	2, 3 PCLKB	2 ICLK	SClg, SClh
0008 A040h	SCI2	Serial Mode Register	SMR	8	8	2, 3 PCLKB	2 ICLK	SClg, SClh
0008 A041h	SCI2	Bit Rate Register	BRR	8	8	2, 3 PCLKB	2 ICLK	SClg, SClh
0008 A042h	SCI2	Serial Control Register	SCR	8	8	2, 3 PCLKB	2 ICLK	SClg, SClh
0008 A043h	SCI2	Transmit Data Register	TDR	8	8	2, 3 PCLKB	2 ICLK	SClg, SClh
0008 A044h	SCI2	Serial Status Register	SSR	8	8	2, 3 PCLKB	2 ICLK	SClg, SClh
0008 A045h	SCI2	Receive Data Register	RDR	8	8	2, 3 PCLKB	2 ICLK	SClg, SClh
0008 A046h	SMCI2	Smart Card Mode Register	SCMR	8	8	2, 3 PCLKB	2 ICLK	SClg, SClh
0008 A047h	SCI2	Serial Extended Mode Register	SEMR	8	8	2, 3 PCLKB	2 ICLK	SClg, SClh
0008 A048h	SCI2	Noise Filter Setting Register	SNFR	8	8	2, 3 PCLKB	2 ICLK	SClg, SClh
0008 A049h	SCI2	I ² C Mode Register 1	SIMR1	8	8	2, 3 PCLKB	2 ICLK	SClg, SClh
0008 A04Ah	SCI2	I ² C Mode Register 2	SIMR2	8	8	2, 3 PCLKB	2 ICLK	SClg, SClh
0008 A04Bh	SCI2	I ² C Mode Register 3	SIMR3	8	8	2, 3 PCLKB	2 ICLK	SClg, SClh
0008 A04Ch	SCI2	I ² C Status Register	SISR	8	8	2, 3 PCLKB	2 ICLK	SClg, SClh
0008 A04Dh	SCI2	SPI Mode Register	SPMR	8	8	2, 3 PCLKB	2 ICLK	SClg, SClh
0008 A04Eh	SCI2	Transmit Data Register H	TDRH	8	8	2, 3 PCLKB	2 ICLK	SClg, SClh
0008 A04Fh	SCI2	Transmit Data Register L	TDRL	8	8	2, 3 PCLKB	2 ICLK	SClg, SClh
0008 A04Eh	SCI2	Transmit Data Register HL	TDRHL	16	16	4, 5 PCLKB	2 ICLK	SClg, SClh
0008 A050h	SCI2	Receive Data Register H	RDRH	8	8	2, 3 PCLKB	2 ICLK	SClg, SClh
0008 A051h	SCI2	Receive Data Register L	RDRL	8	8	2, 3 PCLKB	2 ICLK	SClg, SClh
0008 A050h	SCI2	Receive Data Register HL	RDRHL	16	16	4, 5 PCLKB	2 ICLK	SClg, SClh
0008 A052h	SCI2	Modulation Duty Register	MDDR	8	8	2, 3 PCLKB	2 ICLK	SClg, SClh
0008 A060h	SCI3	Serial Mode Register	SMR	8	8	2, 3 PCLKB	2 ICLK	SClg, SClh
0008 A061h	SCI3	Bit Rate Register	BRR	8	8	2, 3 PCLKB	2 ICLK	SClg, SClh
0008 A062h	SCI3	Serial Control Register	SCR	8	8	2, 3 PCLKB	2 ICLK	SClg, SClh
0008 A063h	SCI3	Transmit Data Register	TDR	8	8	2, 3 PCLKB	2 ICLK	SClg, SClh
0008 A064h	SCI3	Serial Status Register	SSR	8	8	2, 3 PCLKB	2 ICLK	SClg, SClh

Table 4.1 List of I/O Registers (Address Order) (24 / 70)

Address	Module Symbol	Register Name	Register Symbol	Number of Bits	Access Size	Number of Access Cycles		Related Function
						ICLK ≥ PCLK	ICLK < PCLK	
0008 A065h	SCI3	Receive Data Register	RDR	8	8	2, 3 PCLKB	2 ICLK	SClg, SClh
0008 A066h	SMCI3	Smart Card Mode Register	SCMR	8	8	2, 3 PCLKB	2 ICLK	SClg, SClh
0008 A067h	SCI3	Serial Extended Mode Register	SEMR	8	8	2, 3 PCLKB	2 ICLK	SClg, SClh
0008 A068h	SCI3	Noise Filter Setting Register	SNFR	8	8	2, 3 PCLKB	2 ICLK	SClg, SClh
0008 A069h	SCI3	I ² C Mode Register 1	SIMR1	8	8	2, 3 PCLKB	2 ICLK	SClg, SClh
0008 A06Ah	SCI3	I ² C Mode Register 2	SIMR2	8	8	2, 3 PCLKB	2 ICLK	SClg, SClh
0008 A06Bh	SCI3	I ² C Mode Register 3	SIMR3	8	8	2, 3 PCLKB	2 ICLK	SClg, SClh
0008 A06Ch	SCI3	I ² C Status Register	SISR	8	8	2, 3 PCLKB	2 ICLK	SClg, SClh
0008 A06Dh	SCI3	SPI Mode Register	SPMR	8	8	2, 3 PCLKB	2 ICLK	SClg, SClh
0008 A06Eh	SCI3	Transmit Data Register H	TDRH	8	8	2, 3 PCLKB	2 ICLK	SClg, SClh
0008 A06Fh	SCI3	Transmit Data Register L	TDRL	8	8	2, 3 PCLKB	2 ICLK	SClg, SClh
0008 A06Eh	SCI3	Transmit Data Register HL	TDRHL	16	16	4, 5 PCLKB	2 ICLK	SClg, SClh
0008 A070h	SCI3	Receive Data Register H	RDRH	8	8	2, 3 PCLKB	2 ICLK	SClg, SClh
0008 A071h	SCI3	Receive Data Register L	RDRL	8	8	2, 3 PCLKB	2 ICLK	SClg, SClh
0008 A070h	SCI3	Receive Data Register HL	RDRHL	16	16	4, 5 PCLKB	2 ICLK	SClg, SClh
0008 A072h	SCI3	Modulation Duty Register	MDDR	8	8	2, 3 PCLKB	2 ICLK	SClg, SClh
0008 A080h	SCI4	Serial Mode Register	SMR	8	8	2, 3 PCLKB	2 ICLK	SClg, SClh
0008 A081h	SCI4	Bit Rate Register	BRR	8	8	2, 3 PCLKB	2 ICLK	SClg, SClh
0008 A082h	SCI4	Serial Control Register	SCR	8	8	2, 3 PCLKB	2 ICLK	SClg, SClh
0008 A083h	SCI4	Transmit Data Register	TDR	8	8	2, 3 PCLKB	2 ICLK	SClg, SClh
0008 A084h	SCI4	Serial Status Register	SSR	8	8	2, 3 PCLKB	2 ICLK	SClg, SClh
0008 A085h	SCI4	Receive Data Register	RDR	8	8	2, 3 PCLKB	2 ICLK	SClg, SClh
0008 A086h	SMCI4	Smart Card Mode Register	SCMR	8	8	2, 3 PCLKB	2 ICLK	SClg, SClh
0008 A087h	SCI4	Serial Extended Mode Register	SEMR	8	8	2, 3 PCLKB	2 ICLK	SClg, SClh
0008 A088h	SCI4	Noise Filter Setting Register	SNFR	8	8	2, 3 PCLKB	2 ICLK	SClg, SClh
0008 A089h	SCI4	I ² C Mode Register 1	SIMR1	8	8	2, 3 PCLKB	2 ICLK	SClg, SClh
0008 A08Ah	SCI4	I ² C Mode Register 2	SIMR2	8	8	2, 3 PCLKB	2 ICLK	SClg, SClh
0008 A08Bh	SCI4	I ² C Mode Register 3	SIMR3	8	8	2, 3 PCLKB	2 ICLK	SClg, SClh
0008 A08Ch	SCI4	I ² C Status Register	SISR	8	8	2, 3 PCLKB	2 ICLK	SClg, SClh
0008 A08Dh	SCI4	SPI Mode Register	SPMR	8	8	2, 3 PCLKB	2 ICLK	SClg, SClh
0008 A08Eh	SCI4	Transmit Data Register H	TDRH	8	8	2, 3 PCLKB	2 ICLK	SClg, SClh

Table 4.1 List of I/O Registers (Address Order) (25 / 70)

Address	Module Symbol	Register Name	Register Symbol	Number of Bits	Access Size	Number of Access Cycles		Related Function
						ICLK ≥ PCLK	ICLK < PCLK	
0008 A08Fh	SCI4	Transmit Data Register L	TDRL	8	8	2, 3 PCLKB	2 ICLK	SClg, SClh
0008 A08Eh	SCI4	Transmit Data Register HL	TDRHL	16	16	4, 5 PCLKB	2 ICLK	SClg, SClh
0008 A090h	SCI4	Receive Data Register H	RDRH	8	8	2, 3 PCLKB	2 ICLK	SClg, SClh
0008 A091h	SCI4	Receive Data Register L	RDRL	8	8	2, 3 PCLKB	2 ICLK	SClg, SClh
0008 A090h	SCI4	Receive Data Register HL	RDRHL	16	16	4, 5 PCLKB	2 ICLK	SClg, SClh
0008 A092h	SCI4	Modulation Duty Register	MDDR	8	8	2, 3 PCLKB	2 ICLK	SClg, SClh
0008 A0A0h	SCI5	Serial Mode Register	SMR	8	8	2, 3 PCLKB	2 ICLK	SClg, SClh
0008 A0A1h	SCI5	Bit Rate Register	BRR	8	8	2, 3 PCLKB	2 ICLK	SClg, SClh
0008 A0A2h	SCI5	Serial Control Register	SCR	8	8	2, 3 PCLKB	2 ICLK	SClg, SClh
0008 A0A3h	SCI5	Transmit Data Register	TDR	8	8	2, 3 PCLKB	2 ICLK	SClg, SClh
0008 A0A4h	SCI5	Serial Status Register	SSR	8	8	2, 3 PCLKB	2 ICLK	SClg, SClh
0008 A0A5h	SCI5	Receive Data Register	RDR	8	8	2, 3 PCLKB	2 ICLK	SClg, SClh
0008 A0A6h	SMCI5	Smart Card Mode Register	SCMR	8	8	2, 3 PCLKB	2 ICLK	SClg, SClh
0008 A0A7h	SCI5	Serial Extended Mode Register	SEMR	8	8	2, 3 PCLKB	2 ICLK	SClg, SClh
0008 A0A8h	SCI5	Noise Filter Setting Register	SNFR	8	8	2, 3 PCLKB	2 ICLK	SClg, SClh
0008 A0A9h	SCI5	I ² C Mode Register 1	SIMR1	8	8	2, 3 PCLKB	2 ICLK	SClg, SClh
0008 A0AAh	SCI5	I ² C Mode Register 2	SIMR2	8	8	2, 3 PCLKB	2 ICLK	SClg, SClh
0008 A0ABh	SCI5	I ² C Mode Register 3	SIMR3	8	8	2, 3 PCLKB	2 ICLK	SClg, SClh
0008 A0ACh	SCI5	I ² C Status Register	SISR	8	8	2, 3 PCLKB	2 ICLK	SClg, SClh
0008 A0ADh	SCI5	SPI Mode Register	SPMR	8	8	2, 3 PCLKB	2 ICLK	SClg, SClh
0008 A0AEh	SCI5	Transmit Data Register H	TDRH	8	8	2, 3 PCLKB	2 ICLK	SClg, SClh
0008 A0AFh	SCI5	Transmit Data Register L	TDRL	8	8	2, 3 PCLKB	2 ICLK	SClg, SClh
0008 A0AEh	SCI5	Transmit Data Register HL	TDRHL	16	16	4, 5 PCLKB	2 ICLK	SClg, SClh
0008 A0B0h	SCI5	Receive Data Register H	RDRH	8	8	2, 3 PCLKB	2 ICLK	SClg, SClh
0008 A0B1h	SCI5	Receive Data Register L	RDRL	8	8	2, 3 PCLKB	2 ICLK	SClg, SClh
0008 A0B0h	SCI5	Receive Data Register HL	RDRHL	16	16	4, 5 PCLKB	2 ICLK	SClg, SClh
0008 A0B2h	SCI5	Modulation Duty Register	MDDR	8	8	2, 3 PCLKB	2 ICLK	SClg, SClh
0008 A0C0h	SCI6	Serial Mode Register	SMR	8	8	2, 3 PCLKB	2 ICLK	SClg, SClh
0008 A0C1h	SCI6	Bit Rate Register	BRR	8	8	2, 3 PCLKB	2 ICLK	SClg, SClh
0008 A0C2h	SCI6	Serial Control Register	SCR	8	8	2, 3 PCLKB	2 ICLK	SClg, SClh
0008 A0C3h	SCI6	Transmit Data Register	TDR	8	8	2, 3 PCLKB	2 ICLK	SClg, SClh

Table 4.1 List of I/O Registers (Address Order) (26 / 70)

Address	Module Symbol	Register Name	Register Symbol	Number of Bits	Access Size	Number of Access Cycles		Related Function
						ICLK ≥ PCLK	ICLK < PCLK	
0008 A0C4h	SCI6	Serial Status Register	SSR	8	8	2, 3 PCLKB	2 ICLK	SClg, SClh
0008 A0C5h	SCI6	Receive Data Register	RDR	8	8	2, 3 PCLKB	2 ICLK	SClg, SClh
0008 A0C6h	SMCI6	Smart Card Mode Register	SCMR	8	8	2, 3 PCLKB	2 ICLK	SClg, SClh
0008 A0C7h	SCI6	Serial Extended Mode Register	SEMR	8	8	2, 3 PCLKB	2 ICLK	SClg, SClh
0008 A0C8h	SCI6	Noise Filter Setting Register	SNFR	8	8	2, 3 PCLKB	2 ICLK	SClg, SClh
0008 A0C9h	SCI6	I ² C Mode Register 1	SIMR1	8	8	2, 3 PCLKB	2 ICLK	SClg, SClh
0008 A0CAh	SCI6	I ² C Mode Register 2	SIMR2	8	8	2, 3 PCLKB	2 ICLK	SClg, SClh
0008 A0CBh	SCI6	I ² C Mode Register 3	SIMR3	8	8	2, 3 PCLKB	2 ICLK	SClg, SClh
0008 A0CCh	SCI6	I ² C Status Register	SISR	8	8	2, 3 PCLKB	2 ICLK	SClg, SClh
0008 A0CDh	SCI6	SPI Mode Register	SPMR	8	8	2, 3 PCLKB	2 ICLK	SClg, SClh
0008 A0CEh	SCI6	Transmit Data Register H	TDRH	8	8	2, 3 PCLKB	2 ICLK	SClg, SClh
0008 A0CFh	SCI6	Transmit Data Register L	TDRL	8	8	2, 3 PCLKB	2 ICLK	SClg, SClh
0008 A0CEh	SCI6	Transmit Data Register HL	TDRHL	16	16	4, 5 PCLKB	2 ICLK	SClg, SClh
0008 A0D0h	SCI6	Receive Data Register H	RDRH	8	8	2, 3 PCLKB	2 ICLK	SClg, SClh
0008 A0D1h	SCI6	Receive Data Register L	RDRL	8	8	2, 3 PCLKB	2 ICLK	SClg, SClh
0008 A0D0h	SCI6	Receive Data Register HL	RDRHL	16	16	4, 5 PCLKB	2 ICLK	SClg, SClh
0008 A0D2h	SCI6	Modulation Duty Register	MDDR	8	8	2, 3 PCLKB	2 ICLK	SClg, SClh
0008 A0E0h	SCI7	Serial Mode Register	SMR	8	8	2, 3 PCLKB	2 ICLK	SClg, SClh
0008 A0E1h	SCI7	Bit Rate Register	BRR	8	8	2, 3 PCLKB	2 ICLK	SClg, SClh
0008 A0E2h	SCI7	Serial Control Register	SCR	8	8	2, 3 PCLKB	2 ICLK	SClg, SClh
0008 A0E3h	SCI7	Transmit Data Register	TDR	8	8	2, 3 PCLKB	2 ICLK	SClg, SClh
0008 A0E4h	SCI7	Serial Status Register	SSR	8	8	2, 3 PCLKB	2 ICLK	SClg, SClh
0008 A0E5h	SCI7	Receive Data Register	RDR	8	8	2, 3 PCLKB	2 ICLK	SClg, SClh
0008 A0E6h	SMCI7	Smart Card Mode Register	SCMR	8	8	2, 3 PCLKB	2 ICLK	SClg, SClh
0008 A0E7h	SCI7	Serial Extended Mode Register	SEMR	8	8	2, 3 PCLKB	2 ICLK	SClg, SClh
0008 A0E8h	SCI7	Noise Filter Setting Register	SNFR	8	8	2, 3 PCLKB	2 ICLK	SClg, SClh
0008 A0E9h	SCI7	I ² C Mode Register 1	SIMR1	8	8	2, 3 PCLKB	2 ICLK	SClg, SClh
0008 A0EAh	SCI7	I ² C Mode Register 2	SIMR2	8	8	2, 3 PCLKB	2 ICLK	SClg, SClh
0008 A0EBh	SCI7	I ² C Mode Register 3	SIMR3	8	8	2, 3 PCLKB	2 ICLK	SClg, SClh
0008 A0ECh	SCI7	I ² C Status Register	SISR	8	8	2, 3 PCLKB	2 ICLK	SClg, SClh
0008 A0EDh	SCI7	SPI Mode Register	SPMR	8	8	2, 3 PCLKB	2 ICLK	SClg, SClh

Table 4.1 List of I/O Registers (Address Order) (27 / 70)

Address	Module Symbol	Register Name	Register Symbol	Number of Bits	Access Size	Number of Access Cycles		Related Function
						ICLK ≥ PCLK	ICLK < PCLK	
0008 A0EEh	SCI7	Transmit Data Register H	TDRH	8	8	2, 3 PCLKB	2 ICLK	SClg, SClh
0008 A0EFh	SCI7	Transmit Data Register L	TDRL	8	8	2, 3 PCLKB	2 ICLK	SClg, SClh
0008 A0EEh	SCI7	Transmit Data Register HL	TDRHL	16	16	4, 5 PCLKB	2 ICLK	SClg, SClh
0008 A0F0h	SCI7	Receive Data Register H	RDRH	8	8	2, 3 PCLKB	2 ICLK	SClg, SClh
0008 A0F1h	SCI7	Receive Data Register L	RDRL	8	8	2, 3 PCLKB	2 ICLK	SClg, SClh
0008 A0F0h	SCI7	Receive Data Register HL	RDRHL	16	16	4, 5 PCLKB	2 ICLK	SClg, SClh
0008 A0F2h	SCI7	Modulation Duty Register	MDDR	8	8	2, 3 PCLKB	2 ICLK	SClg, SClh
0008 A500h	SSIO	Control Register	SSICR	32	32	2, 3 PCLKB	2 ICLK	SSI
0008 A504h	SSIO	Status Register	SSISR	32	32	2, 3 PCLKB	2 ICLK	SSI
0008 A510h	SSIO	FIFO Control Register	SSIFCR	32	32	2, 3 PCLKB	2 ICLK	SSI
0008 A514h	SSIO	FIFO Status Register	SSIFSR	32	32	2, 3 PCLKB	2 ICLK	SSI
0008 A518h	SSIO	Transmit FIFO Data Register	SSIFTDR	32	32	2, 3 PCLKB	2 ICLK	SSI
0008 A51Ch	SSIO	Receive FIFO Data Register	SSIFRDR	32	32	2, 3 PCLKB	2 ICLK	SSI
0008 A520h	SSIO	TDM Mode Register	SSITDMR	32	32	2, 3 PCLKB	2 ICLK	SSI
0008 A540h	SSI1	Control Register	SSICR	32	32	2, 3 PCLKB	2 ICLK	SSI
0008 A544h	SSI1	Status Register	SSISR	32	32	2, 3 PCLKB	2 ICLK	SSI
0008 A550h	SSI1	FIFO Control Register	SSIFCR	32	32	2, 3 PCLKB	2 ICLK	SSI
0008 A554h	SSI1	FIFO Status Register	SSIFSR	32	32	2, 3 PCLKB	2 ICLK	SSI
0008 A558h	SSI1	Transmit FIFO Data Register	SSIFTDR	32	32	2, 3 PCLKB	2 ICLK	SSI
0008 A55Ch	SSI1	Receive FIFO Data Register	SSIFRDR	32	32	2, 3 PCLKB	2 ICLK	SSI
0008 A560h	SSI1	TDM Mode Register	SSITDMR	32	32	2, 3 PCLKB	2 ICLK	SSI
0008 AC00h	SDHI	Command Register	SDCMD	32	32	2, 3 PCLKB	2 ICLK	SDHI
0008 AC08h	SDHI	Argument Register	SDARG	32	32	2, 3 PCLKB	2 ICLK	SDHI
0008 AC10h	SDHI	Data Stop Register	SDSTOP	32	32	2, 3 PCLKB	2 ICLK	SDHI
0008 AC14h	SDHI	Block Count Register	SDBLKCNT	32	32	2, 3 PCLKB	2 ICLK	SDHI
0008 AC18h	SDHI	Response Register 10	SDRSP10	32	32	2, 3 PCLKB	2 ICLK	SDHI
0008 AC20h	SDHI	Response Register 32	SDRSP32	32	32	2, 3 PCLKB	2 ICLK	SDHI
0008 AC28h	SDHI	Response Register 54	SDRSP54	32	32	2, 3 PCLKB	2 ICLK	SDHI
0008 AC30h	SDHI	Response Register 76	SDRSP76	32	32	2, 3 PCLKB	2 ICLK	SDHI
0008 AC38h	SDHI	SD Status Register 1	SDSTS1	32	32	2, 3 PCLKB	2 ICLK	SDHI
0008 AC3Ch	SDHI	SD Status Register 2	SDSTS2	32	32	2, 3 PCLKB	2 ICLK	SDHI
0008 AC40h	SDHI	SD Interrupt Mask Register 1	SDIMSK1	32	32	2, 3 PCLKB	2 ICLK	SDHI
0008 AC44h	SDHI	SD Interrupt Mask Register 2	SDIMSK2	32	32	2, 3 PCLKB	2 ICLK	SDHI
0008 AC48h	SDHI	SDHI Clock Control Register	SDCLKCR	32	32	2, 3 PCLKB	2 ICLK	SDHI
0008 AC4Ch	SDHI	Transfer Data Size Register	SDSIZE	32	32	2, 3 PCLKB	2 ICLK	SDHI
0008 AC50h	SDHI	Card Access Option Register	SDOPT	32	32	2, 3 PCLKB	2 ICLK	SDHI
0008 AC58h	SDHI	SD Error Status Register 1	SDERSTS1	32	32	2, 3 PCLKB	2 ICLK	SDHI
0008 AC5Ch	SDHI	SD Error Status Register 2	SDERSTS2	32	32	2, 3 PCLKB	2 ICLK	SDHI
0008 AC60h	SDHI	SD Buffer Register	SDBUFR	32	32	2, 3 PCLKB	2 ICLK	SDHI
0008 AC68h	SDHI	SDIO Mode Control Register	SDIOMD	32	32	2, 3 PCLKB	2 ICLK	SDHI
0008 AC6Ch	SDHI	SDIO Status Register	SDIOSTS	32	32	2, 3 PCLKB	2 ICLK	SDHI
0008 AC70h	SDHI	SDIO Interrupt Mask Register	SDIOIMSK	32	32	2, 3 PCLKB	2 ICLK	SDHI
0008 ADB0h	SDHI	DMA Transfer Enable Register	SDDMAEN	32	32	2, 3 PCLKB	2 ICLK	SDHI
0008 ADC0h	SDHI	SDHI Software Reset Register	SDRST	32	32	2, 3 PCLKB	2 ICLK	SDHI
0008 ADC4h	SDHI	Version Register	SDVER	32	32	2, 3 PCLKB	2 ICLK	SDHI
0008 ADE0h	SDHI	Swap Control Register	SDSWAP	32	32	2, 3 PCLKB	2 ICLK	SDHI

Table 4.1 List of I/O Registers (Address Order) (28 / 70)

Address	Module Symbol	Register Name	Register Symbol	Number of Bits	Access Size	Number of Access Cycles		Related Function
						ICLK ≥ PCLK	ICLK < PCLK	
0008 B000h	CAC	CAC Control Register 0	CACR0	8	8	2, 3 PCLKB	2 ICLK	CAC
0008 B001h	CAC	CAC Control Register 1	CACR1	8	8	2, 3 PCLKB	2 ICLK	CAC
0008 B002h	CAC	CAC Control Register 2	CACR2	8	8	2, 3 PCLKB	2 ICLK	CAC
0008 B003h	CAC	CAC Interrupt Request Enable Register	CAICR	8	8	2, 3 PCLKB	2 ICLK	CAC
0008 B004h	CAC	CAC Status Register	CASTR	8	8	2, 3 PCLKB	2 ICLK	CAC
0008 B006h	CAC	CAC Upper-Limit Value Setting Register	CAULVR	16	16	2, 3 PCLKB	2 ICLK	CAC
0008 B008h	CAC	CAC Lower-Limit Value Setting Register	CALLVR	16	16	2, 3 PCLKB	2 ICLK	CAC
0008 B00Ah	CAC	CAC Counter Buffer Register	CACNTBR	16	16	2, 3 PCLKB	2 ICLK	CAC
0008 B080h	DOC	DOC Control Register	DOCR	8	8	2, 3 PCLKB	2 ICLK	DOC
0008 B082h	DOC	DOC Data Input Register	DODIR	16	16	2, 3 PCLKB	2 ICLK	DOC
0008 B084h	DOC	DOC Data Setting Register	DODSR	16	16	2, 3 PCLKB	2 ICLK	DOC
0008 B100h	ELC	Event Link Control Register	ELCR	8	8	2, 3 PCLKB	2 ICLK	ELC
0008 B101h	ELC	Event Link Setting Register 0	ELSR0	8	8	2, 3 PCLKB	2 ICLK	ELC
0008 B104h	ELC	Event Link Setting Register 3	ELSR3	8	8	2, 3 PCLKB	2 ICLK	ELC
0008 B105h	ELC	Event Link Setting Register 4	ELSR4	8	8	2, 3 PCLKB	2 ICLK	ELC
0008 B108h	ELC	Event Link Setting Register 7	ELSR7	8	8	2, 3 PCLKB	2 ICLK	ELC
0008 B10Bh	ELC	Event Link Setting Register 10	ELSR10	8	8	2, 3 PCLKB	2 ICLK	ELC
0008 B10Ch	ELC	Event Link Setting Register 11	ELSR11	8	8	2, 3 PCLKB	2 ICLK	ELC
0008 B10Dh	ELC	Event Link Setting Register 12	ELSR12	8	8	2, 3 PCLKB	2 ICLK	ELC
0008 B10Eh	ELC	Event Link Setting Register 13	ELSR13	8	8	2, 3 PCLKB	2 ICLK	ELC
0008 B110h	ELC	Event Link Setting Register 15	ELSR15	8	8	2, 3 PCLKB	2 ICLK	ELC
0008 B111h	ELC	Event Link Setting Register 16	ELSR16	8	8	2, 3 PCLKB	2 ICLK	ELC
0008 B113h	ELC	Event Link Setting Register 18	ELSR18	8	8	2, 3 PCLKB	2 ICLK	ELC
0008 B114h	ELC	Event Link Setting Register 19	ELSR19	8	8	2, 3 PCLKB	2 ICLK	ELC
0008 B115h	ELC	Event Link Setting Register 20	ELSR20	8	8	2, 3 PCLKB	2 ICLK	ELC
0008 B116h	ELC	Event Link Setting Register 21	ELSR21	8	8	2, 3 PCLKB	2 ICLK	ELC
0008 B117h	ELC	Event Link Setting Register 22	ELSR22	8	8	2, 3 PCLKB	2 ICLK	ELC
0008 B118h	ELC	Event Link Setting Register 23	ELSR23	8	8	2, 3 PCLKB	2 ICLK	ELC
0008 B119h	ELC	Event Link Setting Register 24	ELSR24	8	8	2, 3 PCLKB	2 ICLK	ELC
0008 B11Ah	ELC	Event Link Setting Register 25	ELSR25	8	8	2, 3 PCLKB	2 ICLK	ELC
0008 B11Bh	ELC	Event Link Setting Register 26	ELSR26	8	8	2, 3 PCLKB	2 ICLK	ELC
0008 B11Ch	ELC	Event Link Setting Register 27	ELSR27	8	8	2, 3 PCLKB	2 ICLK	ELC
0008 B11Dh	ELC	Event Link Setting Register 28	ELSR28	8	8	2, 3 PCLKB	2 ICLK	ELC
0008 B11Fh	ELC	Event Link Option Setting Register A	ELOPA	8	8	2, 3 PCLKB	2 ICLK	ELC
0008 B120h	ELC	Event Link Option Setting Register B	ELOPB	8	8	2, 3 PCLKB	2 ICLK	ELC
0008 B121h	ELC	Event Link Option Setting Register C	ELOPC	8	8	2, 3 PCLKB	2 ICLK	ELC
0008 B122h	ELC	Event Link Option Setting Register D	ELOPD	8	8	2, 3 PCLKB	2 ICLK	ELC
0008 B123h	ELC	Port Group Setting Register 1	PGR1	8	8	2, 3 PCLKB	2 ICLK	ELC
0008 B124h	ELC	Port Group Setting Register 2	PGR2	8	8	2, 3 PCLKB	2 ICLK	ELC
0008 B125h	ELC	Port Group Control Register 1	PGC1	8	8	2, 3 PCLKB	2 ICLK	ELC
0008 B126h	ELC	Port Group Control Register 2	PGC2	8	8	2, 3 PCLKB	2 ICLK	ELC
0008 B127h	ELC	Port Buffer Register 1	PDBF1	8	8	2, 3 PCLKB	2 ICLK	ELC
0008 B128h	ELC	Port Buffer Register 2	PDBF2	8	8	2, 3 PCLKB	2 ICLK	ELC
0008 B129h	ELC	Event Link Port Setting Register 0	PEL0	8	8	2, 3 PCLKB	2 ICLK	ELC
0008 B12Ah	ELC	Event Link Port Setting Register 1	PEL1	8	8	2, 3 PCLKB	2 ICLK	ELC
0008 B12Bh	ELC	Event Link Port Setting Register 2	PEL2	8	8	2, 3 PCLKB	2 ICLK	ELC
0008 B12Ch	ELC	Event Link Port Setting Register 3	PEL3	8	8	2, 3 PCLKB	2 ICLK	ELC
0008 B12Dh	ELC	Event Link Software Event Generation Register	ELSEGR	8	8	2, 3 PCLKB	2 ICLK	ELC
0008 B131h	ELC	Event Link Setting Register 33	ELSR33	8	8	2, 3 PCLKB	2 ICLK	ELC
0008 B133h	ELC	Event Link Setting Register 35	ELSR35	8	8	2, 3 PCLKB	2 ICLK	ELC

Table 4.1 List of I/O Registers (Address Order) (29 / 70)

Address	Module Symbol	Register Name	Register Symbol	Number of Bits	Access Size	Number of Access Cycles		Related Function
						ICLK ≥ PCLK	ICLK < PCLK	
0008 B134h	ELC	Event Link Setting Register 36	ELSR36	8	8	2, 3 PCLKB	2 ICLK	ELC
0008 B135h	ELC	Event Link Setting Register 37	ELSR37	8	8	2, 3 PCLKB	2 ICLK	ELC
0008 B136h	ELC	Event Link Setting Register 38	ELSR38	8	8	2, 3 PCLKB	2 ICLK	ELC
0008 B139h	ELC	Event Link Setting Register 41	ELSR41	8	8	2, 3 PCLKB	2 ICLK	ELC
0008 B13Ah	ELC	Event Link Setting Register 42	ELSR42	8	8	2, 3 PCLKB	2 ICLK	ELC
0008 B13Bh	ELC	Event Link Setting Register 43	ELSR43	8	8	2, 3 PCLKB	2 ICLK	ELC
0008 B13Ch	ELC	Event Link Setting Register 44	ELSR44	8	8	2, 3 PCLKB	2 ICLK	ELC
0008 B13Dh	ELC	Event Link Setting Register 45	ELSR45	8	8	2, 3 PCLKB	2 ICLK	ELC
0008 B13Fh	ELC	Event Link Option Setting Register F	ELOPF	8	8	2, 3 PCLKB	2 ICLK	ELC
0008 B141h	ELC	Event Link Option Setting Register H	ELOPH	8	8	2, 3 PCLKB	2 ICLK	ELC
0008 B142h	ELC	Event Link Option Setting Register I	ELOPI	8	8	2, 3 PCLKB	2 ICLK	ELC
0008 B143h	ELC	Event Link Option Setting Register J	ELOPJ	8	8	2, 3 PCLKB	2 ICLK	ELC
0008 B300h	SCI12	Serial Mode Register	SMR	8	8	2, 3 PCLKB	2 ICLK	SCIh
0008 B301h	SCI12	Bit Rate Register	BRR	8	8	2, 3 PCLKB	2 ICLK	SCIh
0008 B302h	SCI12	Serial Control Register	SCR	8	8	2, 3 PCLKB	2 ICLK	SCIh
0008 B303h	SCI12	Transmit Data Register	TDR	8	8	2, 3 PCLKB	2 ICLK	SCIh
0008 B304h	SCI12	Serial Status Register	SSR	8	8	2, 3 PCLKB	2 ICLK	SCIh
0008 B305h	SCI12	Receive Data Register	RDR	8	8	2, 3 PCLKB	2 ICLK	SCIh
0008 B306h	SMCI12	Smart Card Mode Register	SCMR	8	8	2, 3 PCLKB	2 ICLK	SCIh
0008 B307h	SCI12	Serial Extended Mode Register	SEMR	8	8	2, 3 PCLKB	2 ICLK	SCIh
0008 B308h	SCI12	Noise Filter Setting Register	SNFR	8	8	2, 3 PCLKB	2 ICLK	SCIh
0008 B309h	SCI12	I ² C Mode Register 1	SIMR1	8	8	2, 3 PCLKB	2 ICLK	SCIh
0008 B30Ah	SCI12	I ² C Mode Register 2	SIMR2	8	8	2, 3 PCLKB	2 ICLK	SCIh
0008 B30Bh	SCI12	I ² C Mode Register 3	SIMR3	8	8	2, 3 PCLKB	2 ICLK	SCIh
0008 B30Ch	SCI12	I ² C Status Register	SISR	8	8	2, 3 PCLKB	2 ICLK	SCIh
0008 B30Dh	SCI12	SPI Mode Register	SPMR	8	8	2, 3 PCLKB	2 ICLK	SCIh
0008 B30Eh	SCI12	Transmit Data Register H	TDRH	8	8	2, 3 PCLKB	2 ICLK	SCIh
0008 B30Fh	SCI12	Transmit Data Register L	TDRL	8	8	2, 3 PCLKB	2 ICLK	SCIh
0008 B30Eh	SCI12	Transmit Data Register HL	TDRHL	16	16	4, 5 PCLKB	2 ICLK	SCIh
0008 B310h	SCI12	Receive Data Register H	RDRH	8	8	2, 3 PCLKB	2 ICLK	SCIh
0008 B311h	SCI12	Receive Data Register L	RDRL	8	8	2, 3 PCLKB	2 ICLK	SCIh
0008 B310h	SCI12	Receive Data Register HL	RDRHL	16	16	4, 5 PCLKB	2 ICLK	SCIh
0008 B312h	SCI12	Modulation Duty Register	MDDR	8	8	2, 3 PCLKB	2 ICLK	SCIh
0008 B320h	SCI12	Extended Serial Module Enable Register	ESMER	8	8	2, 3 PCLKB	2 ICLK	SCIh
0008 B321h	SCI12	Control Register 0	CR0	8	8	2, 3 PCLKB	2 ICLK	SCIh
0008 B322h	SCI12	Control Register 1	CR1	8	8	2, 3 PCLKB	2 ICLK	SCIh
0008 B323h	SCI12	Control Register 2	CR2	8	8	2, 3 PCLKB	2 ICLK	SCIh
0008 B324h	SCI12	Control Register 3	CR3	8	8	2, 3 PCLKB	2 ICLK	SCIh
0008 B325h	SCI12	Port Control Register	PCR	8	8	2, 3 PCLKB	2 ICLK	SCIh
0008 B326h	SCI12	Interrupt Control Register	ICR	8	8	2, 3 PCLKB	2 ICLK	SCIh
0008 B327h	SCI12	Status Register	STR	8	8	2, 3 PCLKB	2 ICLK	SCIh
0008 B328h	SCI12	Status Clear Register	STCR	8	8	2, 3 PCLKB	2 ICLK	SCIh
0008 B329h	SCI12	Control Field 0 Data Register	CF0DR	8	8	2, 3 PCLKB	2 ICLK	SCIh
0008 B32Ah	SCI12	Control Field 0 Compare Enable Register	CF0CR	8	8	2, 3 PCLKB	2 ICLK	SCIh
0008 B32Bh	SCI12	Control Field 0 Receive Data Register	CF0RR	8	8	2, 3 PCLKB	2 ICLK	SCIh
0008 B32Ch	SCI12	Primary Control Field 1 Data Register	PCF1DR	8	8	2, 3 PCLKB	2 ICLK	SCIh
0008 B32Dh	SCI12	Secondary Control Field 1 Data Register	SCF1DR	8	8	2, 3 PCLKB	2 ICLK	SCIh
0008 B32Eh	SCI12	Control Field 1 Compare Enable Register	CF1CR	8	8	2, 3 PCLKB	2 ICLK	SCIh
0008 B32Fh	SCI12	Control Field 1 Receive Data Register	CF1RR	8	8	2, 3 PCLKB	2 ICLK	SCIh
0008 B330h	SCI12	Timer Control Register	TCR	8	8	2, 3 PCLKB	2 ICLK	SCIh

Table 4.1 List of I/O Registers (Address Order) (30 / 70)

Address	Module Symbol	Register Name	Register Symbol	Number of Bits	Access Size	Number of Access Cycles		Related Function
						ICLK ≥ PCLK	ICLK < PCLK	
0008 B331h	SCI12	Timer Mode Register	TMR	8	8	2, 3 PCLKB	2 ICLK	SCIh
0008 B332h	SCI12	Timer Prescaler Register	TPRE	8	8	2, 3 PCLKB	2 ICLK	SCIh
0008 B333h	SCI12	Timer Count Register	TCNT	8	8	2, 3 PCLKB	2 ICLK	SCIh
0008 C000h	PORT0	Port Direction Register	PDR	8	8	2, 3 PCLKB	2 ICLK	I/O Ports
0008 C001h	PORT1	Port Direction Register	PDR	8	8	2, 3 PCLKB	2 ICLK	I/O Ports
0008 C002h	PORT2	Port Direction Register	PDR	8	8	2, 3 PCLKB	2 ICLK	I/O Ports
0008 C003h	PORT3	Port Direction Register	PDR	8	8	2, 3 PCLKB	2 ICLK	I/O Ports
0008 C004h	PORT4	Port Direction Register	PDR	8	8	2, 3 PCLKB	2 ICLK	I/O Ports
0008 C005h	PORT5	Port Direction Register	PDR	8	8	2, 3 PCLKB	2 ICLK	I/O Ports
0008 C006h	PORT6	Port Direction Register	PDR	8	8	2, 3 PCLKB	2 ICLK	I/O Ports
0008 C007h	PORT7	Port Direction Register	PDR	8	8	2, 3 PCLKB	2 ICLK	I/O Ports
0008 C008h	PORT8	Port Direction Register	PDR	8	8	2, 3 PCLKB	2 ICLK	I/O Ports
0008 C009h	PORT9	Port Direction Register	PDR	8	8	2, 3 PCLKB	2 ICLK	I/O Ports
0008 C00Ah	PORTA	Port Direction Register	PDR	8	8	2, 3 PCLKB	2 ICLK	I/O Ports
0008 C00Bh	PORTB	Port Direction Register	PDR	8	8	2, 3 PCLKB	2 ICLK	I/O Ports
0008 C00Ch	PORTC	Port Direction Register	PDR	8	8	2, 3 PCLKB	2 ICLK	I/O Ports
0008 C00Dh	PORTD	Port Direction Register	PDR	8	8	2, 3 PCLKB	2 ICLK	I/O Ports
0008 C00Eh	PORTE	Port Direction Register	PDR	8	8	2, 3 PCLKB	2 ICLK	I/O Ports
0008 C00Fh	PORTF	Port Direction Register	PDR	8	8	2, 3 PCLKB	2 ICLK	I/O Ports
0008 C010h	PORTG	Port Direction Register	PDR	8	8	2, 3 PCLKB	2 ICLK	I/O Ports
0008 C012h	PORTJ	Port Direction Register	PDR	8	8	2, 3 PCLKB	2 ICLK	I/O Ports
0008 C020h	PORT0	Port Output Data Register	PODR	8	8	2, 3 PCLKB	2 ICLK	I/O Ports
0008 C021h	PORT1	Port Output Data Register	PODR	8	8	2, 3 PCLKB	2 ICLK	I/O Ports
0008 C022h	PORT2	Port Output Data Register	PODR	8	8	2, 3 PCLKB	2 ICLK	I/O Ports
0008 C023h	PORT3	Port Output Data Register	PODR	8	8	2, 3 PCLKB	2 ICLK	I/O Ports
0008 C024h	PORT4	Port Output Data Register	PODR	8	8	2, 3 PCLKB	2 ICLK	I/O Ports
0008 C025h	PORT5	Port Output Data Register	PODR	8	8	2, 3 PCLKB	2 ICLK	I/O Ports
0008 C026h	PORT6	Port Output Data Register	PODR	8	8	2, 3 PCLKB	2 ICLK	I/O Ports
0008 C027h	PORT7	Port Output Data Register	PODR	8	8	2, 3 PCLKB	2 ICLK	I/O Ports
0008 C028h	PORT8	Port Output Data Register	PODR	8	8	2, 3 PCLKB	2 ICLK	I/O Ports
0008 C029h	PORT9	Port Output Data Register	PODR	8	8	2, 3 PCLKB	2 ICLK	I/O Ports
0008 C02Ah	PORTA	Port Output Data Register	PODR	8	8	2, 3 PCLKB	2 ICLK	I/O Ports
0008 C02Bh	PORTB	Port Output Data Register	PODR	8	8	2, 3 PCLKB	2 ICLK	I/O Ports

Table 4.1 List of I/O Registers (Address Order) (31 / 70)

Address	Module Symbol	Register Name	Register Symbol	Number of Bits	Access Size	Number of Access Cycles		Related Function
						ICLK \geq PCLK	ICLK $<$ PCLK	
0008 C02Ch	PORTC	Port Output Data Register	PODR	8	8	2, 3 PCLKB	2 ICLK	I/O Ports
0008 C02Dh	PORTD	Port Output Data Register	PODR	8	8	2, 3 PCLKB	2 ICLK	I/O Ports
0008 C02Eh	PORTE	Port Output Data Register	PODR	8	8	2, 3 PCLKB	2 ICLK	I/O Ports
0008 C02Fh	PORTF	Port Output Data Register	PODR	8	8	2, 3 PCLKB	2 ICLK	I/O Ports
0008 C030h	PORTG	Port Output Data Register	PODR	8	8	2, 3 PCLKB	2 ICLK	I/O Ports
0008 C032h	PORTJ	Port Output Data Register	PODR	8	8	2, 3 PCLKB	2 ICLK	I/O Ports
0008 C040h	PORT0	Port Input Register	PIDR	8	8	2, 3 PCLKB	2 ICLK	I/O Ports
0008 C041h	PORT1	Port Input Register	PIDR	8	8	2, 3 PCLKB	2 ICLK	I/O Ports
0008 C042h	PORT2	Port Input Register	PIDR	8	8	2, 3 PCLKB	2 ICLK	I/O Ports
0008 C043h	PORT3	Port Input Register	PIDR	8	8	2, 3 PCLKB	2 ICLK	I/O Ports
0008 C044h	PORT4	Port Input Register	PIDR	8	8	2, 3 PCLKB	2 ICLK	I/O Ports
0008 C045h	PORT5	Port Input Register	PIDR	8	8	2, 3 PCLKB	2 ICLK	I/O Ports
0008 C046h	PORT6	Port Input Register	PIDR	8	8	2, 3 PCLKB	2 ICLK	I/O Ports
0008 C047h	PORT7	Port Input Register	PIDR	8	8	2, 3 PCLKB	2 ICLK	I/O Ports
0008 C048h	PORT8	Port Input Register	PIDR	8	8	2, 3 PCLKB	2 ICLK	I/O Ports
0008 C049h	PORT9	Port Input Register	PIDR	8	8	2, 3 PCLKB	2 ICLK	I/O Ports
0008 C04Ah	PORTA	Port Input Register	PIDR	8	8	2, 3 PCLKB	2 ICLK	I/O Ports
0008 C04Bh	PORTB	Port Input Register	PIDR	8	8	2, 3 PCLKB	2 ICLK	I/O Ports
0008 C04Ch	PORTC	Port Input Register	PIDR	8	8	2, 3 PCLKB	2 ICLK	I/O Ports
0008 C04Dh	PORTD	Port Input Register	PIDR	8	8	2, 3 PCLKB	2 ICLK	I/O Ports
0008 C04Eh	PORTE	Port Input Register	PIDR	8	8	2, 3 PCLKB	2 ICLK	I/O Ports
0008 C04Fh	PORTF	Port Input Register	PIDR	8	8	2, 3 PCLKB	2 ICLK	I/O Ports
0008 C050h	PORTG	Port Input Register	PIDR	8	8	2, 3 PCLKB	2 ICLK	I/O Ports
0008 C052h	PORTJ	Port Input Register	PIDR	8	8	2, 3 PCLKB	2 ICLK	I/O Ports
0008 C060h	PORT0	Port Mode Register	PMR	8	8	2, 3 PCLKB	2 ICLK	I/O Ports
0008 C061h	PORT1	Port Mode Register	PMR	8	8	2, 3 PCLKB	2 ICLK	I/O Ports
0008 C062h	PORT2	Port Mode Register	PMR	8	8	2, 3 PCLKB	2 ICLK	I/O Ports
0008 C063h	PORT3	Port Mode Register	PMR	8	8	2, 3 PCLKB	2 ICLK	I/O Ports
0008 C064h	PORT4	Port Mode Register	PMR	8	8	2, 3 PCLKB	2 ICLK	I/O Ports
0008 C065h	PORT5	Port Mode Register	PMR	8	8	2, 3 PCLKB	2 ICLK	I/O Ports
0008 C066h	PORT6	Port Mode Register	PMR	8	8	2, 3 PCLKB	2 ICLK	I/O Ports

Table 4.1 List of I/O Registers (Address Order) (32 / 70)

Address	Module Symbol	Register Name	Register Symbol	Number of Bits	Access Size	Number of Access Cycles		Related Function
						ICLK ≥ PCLK	ICLK < PCLK	
0008 C067h	PORT7	Port Mode Register	PMR	8	8	2, 3 PCLKB	2 ICLK	I/O Ports
0008 C068h	PORT8	Port Mode Register	PMR	8	8	2, 3 PCLKB	2 ICLK	I/O Ports
0008 C069h	PORT9	Port Mode Register	PMR	8	8	2, 3 PCLKB	2 ICLK	I/O Ports
0008 C06Ah	PORTA	Port Mode Register	PMR	8	8	2, 3 PCLKB	2 ICLK	I/O Ports
0008 C06Bh	PORTB	Port Mode Register	PMR	8	8	2, 3 PCLKB	2 ICLK	I/O Ports
0008 C06Ch	PORTC	Port Mode Register	PMR	8	8	2, 3 PCLKB	2 ICLK	I/O Ports
0008 C06Dh	PORTD	Port Mode Register	PMR	8	8	2, 3 PCLKB	2 ICLK	I/O Ports
0008 C06Eh	PORTE	Port Mode Register	PMR	8	8	2, 3 PCLKB	2 ICLK	I/O Ports
0008 C06Fh	PORTF	Port Mode Register	PMR	8	8	2, 3 PCLKB	2 ICLK	I/O Ports
0008 C070h	PORTG	Port Mode Register	PMR	8	8	2, 3 PCLKB	2 ICLK	I/O Ports
0008 C072h	PORTJ	Port Mode Register	PMR	8	8	2, 3 PCLKB	2 ICLK	I/O Ports
0008 C080h	PORT0	Open-Drain Control Register 0	ODR0	8	8	2, 3 PCLKB	2 ICLK	I/O Ports
0008 C081h	PORT0	Open-Drain Control Register 1	ODR1	8	8	2, 3 PCLKB	2 ICLK	I/O Ports
0008 C082h	PORT1	Open-Drain Control Register 0	ODR0	8	8	2, 3 PCLKB	2 ICLK	I/O Ports
0008 C083h	PORT1	Open-Drain Control Register 1	ODR1	8	8	2, 3 PCLKB	2 ICLK	I/O Ports
0008 C084h	PORT2	Open-Drain Control Register 0	ODR0	8	8	2, 3 PCLKB	2 ICLK	I/O Ports
0008 C085h	PORT2	Open-Drain Control Register 1	ODR1	8	8	2, 3 PCLKB	2 ICLK	I/O Ports
0008 C086h	PORT3	Open-Drain Control Register 0	ODR0	8	8	2, 3 PCLKB	2 ICLK	I/O Ports
0008 C087h	PORT3	Open-Drain Control Register 1	ODR1	8	8	2, 3 PCLKB	2 ICLK	I/O Ports
0008 C088h	PORT4	Open-Drain Control Register 0	ODR0	8	8	2, 3 PCLKB	2 ICLK	I/O Ports
0008 C089h	PORT4	Open-Drain Control Register 1	ODR1	8	8	2, 3 PCLKB	2 ICLK	I/O Ports
0008 C08Ah	PORT5	Open-Drain Control Register 0	ODR0	8	8	2, 3 PCLKB	2 ICLK	I/O Ports
0008 C08Bh	PORT5	Open-Drain Control Register 1	ODR1	8	8	2, 3 PCLKB	2 ICLK	I/O Ports
0008 C08Ch	PORT6	Open-Drain Control Register 0	ODR0	8	8	2, 3 PCLKB	2 ICLK	I/O Ports
0008 C08Dh	PORT6	Open-Drain Control Register 1	ODR1	8	8	2, 3 PCLKB	2 ICLK	I/O Ports
0008 C08Eh	PORT7	Open-Drain Control Register 0	ODR0	8	8	2, 3 PCLKB	2 ICLK	I/O Ports
0008 C08Fh	PORT7	Open-Drain Control Register 1	ODR1	8	8	2, 3 PCLKB	2 ICLK	I/O Ports
0008 C090h	PORT8	Open-Drain Control Register 0	ODR0	8	8	2, 3 PCLKB	2 ICLK	I/O Ports
0008 C091h	PORT8	Open-Drain Control Register 1	ODR1	8	8	2, 3 PCLKB	2 ICLK	I/O Ports
0008 C092h	PORT9	Open-Drain Control Register 0	ODR0	8	8	2, 3 PCLKB	2 ICLK	I/O Ports
0008 C093h	PORT9	Open-Drain Control Register 1	ODR1	8	8	2, 3 PCLKB	2 ICLK	I/O Ports

Table 4.1 List of I/O Registers (Address Order) (33 / 70)

Address	Module Symbol	Register Name	Register Symbol	Number of Bits	Access Size	Number of Access Cycles		Related Function
						ICLK ≥ PCLK	ICLK < PCLK	
0008 C094h	PORTA	Open-Drain Control Register 0	ODR0	8	8	2, 3 PCLKB	2 ICLK	I/O Ports
0008 C095h	PORTA	Open-Drain Control Register 1	ODR1	8	8	2, 3 PCLKB	2 ICLK	I/O Ports
0008 C096h	PORTB	Open-Drain Control Register 0	ODR0	8	8	2, 3 PCLKB	2 ICLK	I/O Ports
0008 C097h	PORTB	Open-Drain Control Register 1	ODR1	8	8	2, 3 PCLKB	2 ICLK	I/O Ports
0008 C098h	PORTC	Open-Drain Control Register 0	ODR0	8	8	2, 3 PCLKB	2 ICLK	I/O Ports
0008 C099h	PORTC	Open-Drain Control Register 1	ODR1	8	8	2, 3 PCLKB	2 ICLK	I/O Ports
0008 C09Ah	PORTD	Open-Drain Control Register 0	ODR0	8	8	2, 3 PCLKB	2 ICLK	I/O Ports
0008 C09Bh	PORTD	Open-Drain Control Register 1	ODR1	8	8	2, 3 PCLKB	2 ICLK	I/O Ports
0008 C09Ch	PORTE	Open-Drain Control Register 0	ODR0	8	8	2, 3 PCLKB	2 ICLK	I/O Ports
0008 C09Dh	PORTE	Open-Drain Control Register 1	ODR1	8	8	2, 3 PCLKB	2 ICLK	I/O Ports
0008 C09Eh	PORTF	Open-Drain Control Register 0	ODR0	8	8	2, 3 PCLKB	2 ICLK	I/O Ports
0008 C09Fh	PORTF	Open-Drain Control Register 1	ODR1	8	8	2, 3 PCLKB	2 ICLK	I/O Ports
0008 C0A0h	PORTG	Open-Drain Control Register 0	ODR0	8	8	2, 3 PCLKB	2 ICLK	I/O Ports
0008 C0A1h	PORTG	Open-Drain Control Register 1	ODR1	8	8	2, 3 PCLKB	2 ICLK	I/O Ports
0008 C0A4h	PORTJ	Open-Drain Control Register 0	ODR0	8	8	2, 3 PCLKB	2 ICLK	I/O Ports
0008 C0A5h	PORTJ	Open-Drain Control Register 1	ODR1	8	8	2, 3 PCLKB	2 ICLK	I/O Ports
0008 C0C0h	PORT0	Pull-Up Resistor Control Register	PCR	8	8	2, 3 PCLKB	2 ICLK	I/O Ports
0008 C0C1h	PORT1	Pull-Up Resistor Control Register	PCR	8	8	2, 3 PCLKB	2 ICLK	I/O Ports
0008 C0C2h	PORT2	Pull-Up Resistor Control Register	PCR	8	8	2, 3 PCLKB	2 ICLK	I/O Ports
0008 C0C3h	PORT3	Pull-Up Resistor Control Register	PCR	8	8	2, 3 PCLKB	2 ICLK	I/O Ports
0008 C0C4h	PORT4	Pull-Up Resistor Control Register	PCR	8	8	2, 3 PCLKB	2 ICLK	I/O Ports
0008 C0C5h	PORT5	Pull-Up Resistor Control Register	PCR	8	8	2, 3 PCLKB	2 ICLK	I/O Ports
0008 C0C6h	PORT6	Pull-Up Resistor Control Register	PCR	8	8	2, 3 PCLKB	2 ICLK	I/O Ports
0008 C0C7h	PORT7	Pull-Up Resistor Control Register	PCR	8	8	2, 3 PCLKB	2 ICLK	I/O Ports
0008 C0C8h	PORT8	Pull-Up Resistor Control Register	PCR	8	8	2, 3 PCLKB	2 ICLK	I/O Ports
0008 C0C9h	PORT9	Pull-Up Resistor Control Register	PCR	8	8	2, 3 PCLKB	2 ICLK	I/O Ports
0008 C0CAh	PORTA	Pull-Up Resistor Control Register	PCR	8	8	2, 3 PCLKB	2 ICLK	I/O Ports
0008 C0CBh	PORTB	Pull-Up Resistor Control Register	PCR	8	8	2, 3 PCLKB	2 ICLK	I/O Ports
0008 C0CCh	PORTC	Pull-Up Resistor Control Register	PCR	8	8	2, 3 PCLKB	2 ICLK	I/O Ports
0008 C0CDh	PORTD	Pull-Up Resistor Control Register	PCR	8	8	2, 3 PCLKB	2 ICLK	I/O Ports
0008 C0CEh	PORTE	Pull-Up Resistor Control Register	PCR	8	8	2, 3 PCLKB	2 ICLK	I/O Ports

Table 4.1 List of I/O Registers (Address Order) (34 / 70)

Address	Module Symbol	Register Name	Register Symbol	Number of Bits	Access Size	Number of Access Cycles		Related Function
						ICLK ≥ PCLK	ICLK < PCLK	
0008 C0CFh	PORTF	Pull-Up Resistor Control Register	PCR	8	8	2, 3 PCLKB	2 ICLK	I/O Ports
0008 C0D0h	PORTG	Pull-Up Resistor Control Register	PCR	8	8	2, 3 PCLKB	2 ICLK	I/O Ports
0008 C0D2h	PORTJ	Pull-Up Resistor Control Register	PCR	8	8	2, 3 PCLKB	2 ICLK	I/O Ports
0008 C0E0h	PORT0	Drive Capacity Control Register	DSCR	8	8	2, 3 PCLKB	2 ICLK	I/O Ports
0008 C0E2h	PORT2	Drive Capacity Control Register	DSCR	8	8	2, 3 PCLKB	2 ICLK	I/O Ports
0008 C0E5h	PORT5	Drive Capacity Control Register	DSCR	8	8	2, 3 PCLKB	2 ICLK	I/O Ports
0008 C0E9h	PORT9	Drive Capacity Control Register	DSCR	8	8	2, 3 PCLKB	2 ICLK	I/O Ports
0008 C0EAh	PORTA	Drive Capacity Control Register	DSCR	8	8	2, 3 PCLKB	2 ICLK	I/O Ports
0008 C0EBh	PORTB	Drive Capacity Control Register	DSCR	8	8	2, 3 PCLKB	2 ICLK	I/O Ports
0008 C0ECh	PORTC	Drive Capacity Control Register	DSCR	8	8	2, 3 PCLKB	2 ICLK	I/O Ports
0008 C0EDh	PORTD	Drive Capacity Control Register	DSCR	8	8	2, 3 PCLKB	2 ICLK	I/O Ports
0008 C0EEh	PORTE	Drive Capacity Control Register	DSCR	8	8	2, 3 PCLKB	2 ICLK	I/O Ports
0008 C0F0h	PORTG	Drive Capacity Control Register	DSCR	8	8	2, 3 PCLKB	2 ICLK	I/O Ports
0008 C100h	MPC	CS Output Enable Register	PFCSE	8	8	2, 3 PCLKB	2 ICLK	MPC
0008 C102h	MPC	CS Output Pin Select Register 0	PFCSS0	8	8	2, 3 PCLKB	2 ICLK	MPC
0008 C103h	MPC	CS Output Pin Select Register 1	PFCSS1	8	8	2, 3 PCLKB	2 ICLK	MPC
0008 C104h	MPC	Address Output Enable Register 0	PFAOE0	8	8	2, 3 PCLKB	2 ICLK	MPC
0008 C105h	MPC	Address Output Enable Register 1	PFAOE1	8	8	2, 3 PCLKB	2 ICLK	MPC
0008 C106h	MPC	External Bus Control Register 0	PFBCR0	8	8	2, 3 PCLKB	2 ICLK	MPC
0008 C107h	MPC	External Bus Control Register 1	PFBCR1	8	8	2, 3 PCLKB	2 ICLK	MPC
0008 C10Eh	MPC	Ethernet Control Register	PFENET	8	8	2, 3 PCLKB	2 ICLK	MPC
0008 C11Fh	MPC	Write-Protect Register	PWPR	8	8	2, 3 PCLKB	2 ICLK	MPC
0008 C140h	MPC	P00 Pin Function Control Register	P00PFS	8	8	2, 3 PCLKB	2 ICLK	MPC
0008 C141h	MPC	P01 Pin Function Control Register	P01PFS	8	8	2, 3 PCLKB	2 ICLK	MPC
0008 C142h	MPC	P02 Pin Function Control Register	P02PFS	8	8	2, 3 PCLKB	2 ICLK	MPC
0008 C143h	MPC	P03 Pin Function Control Register	P03PFS	8	8	2, 3 PCLKB	2 ICLK	MPC
0008 C145h	MPC	P05 Pin Function Control Register	P05PFS	8	8	2, 3 PCLKB	2 ICLK	MPC
0008 C147h	MPC	P07 Pin Function Control Register	P07PFS	8	8	2, 3 PCLKB	2 ICLK	MPC
0008 C148h	MPC	P10 Pin Function Control Register	P10PFS	8	8	2, 3 PCLKB	2 ICLK	MPC
0008 C149h	MPC	P11 Pin Function Control Register	P11PFS	8	8	2, 3 PCLKB	2 ICLK	MPC
0008 C14Ah	MPC	P12 Pin Function Control Register	P12PFS	8	8	2, 3 PCLKB	2 ICLK	MPC
0008 C14Bh	MPC	P13 Pin Function Control Register	P13PFS	8	8	2, 3 PCLKB	2 ICLK	MPC
0008 C14Ch	MPC	P14 Pin Function Control Register	P14PFS	8	8	2, 3 PCLKB	2 ICLK	MPC
0008 C14Dh	MPC	P15 Pin Function Control Register	P15PFS	8	8	2, 3 PCLKB	2 ICLK	MPC
0008 C14Eh	MPC	P16 Pin Function Control Register	P16PFS	8	8	2, 3 PCLKB	2 ICLK	MPC
0008 C14Fh	MPC	P17 Pin Function Control Register	P17PFS	8	8	2, 3 PCLKB	2 ICLK	MPC
0008 C150h	MPC	P20 Pin Function Control Register	P20PFS	8	8	2, 3 PCLKB	2 ICLK	MPC
0008 C151h	MPC	P21 Pin Function Control Register	P21PFS	8	8	2, 3 PCLKB	2 ICLK	MPC
0008 C152h	MPC	P22 Pin Function Control Register	P22PFS	8	8	2, 3 PCLKB	2 ICLK	MPC
0008 C153h	MPC	P23 Pin Function Control Register	P23PFS	8	8	2, 3 PCLKB	2 ICLK	MPC
0008 C154h	MPC	P24 Pin Function Control Register	P24PFS	8	8	2, 3 PCLKB	2 ICLK	MPC
0008 C155h	MPC	P25 Pin Function Control Register	P25PFS	8	8	2, 3 PCLKB	2 ICLK	MPC

Table 4.1 List of I/O Registers (Address Order) (35 / 70)

Address	Module Symbol	Register Name	Register Symbol	Number of Bits	Access Size	Number of Access Cycles		Related Function
						ICLK ≥ PCLK	ICLK < PCLK	
0008 C156h	MPC	P26 Pin Function Control Register	P26PFS	8	8	2, 3 PCLKB	2 ICLK	MPC
0008 C157h	MPC	P27 Pin Function Control Register	P27PFS	8	8	2, 3 PCLKB	2 ICLK	MPC
0008 C158h	MPC	P30 Pin Function Control Register	P30PFS	8	8	2, 3 PCLKB	2 ICLK	MPC
0008 C159h	MPC	P31 Pin Function Control Register	P31PFS	8	8	2, 3 PCLKB	2 ICLK	MPC
0008 C15Ah	MPC	P32 Pin Function Control Register	P32PFS	8	8	2, 3 PCLKB	2 ICLK	MPC
0008 C15Bh	MPC	P33 Pin Function Control Register	P33PFS	8	8	2, 3 PCLKB	2 ICLK	MPC
0008 C15Ch	MPC	P34 Pin Function Control Register	P34PFS	8	8	2, 3 PCLKB	2 ICLK	MPC
0008 C160h	MPC	P40 Pin Function Control Register	P40PFS	8	8	2, 3 PCLKB	2 ICLK	MPC
0008 C161h	MPC	P41 Pin Function Control Register	P41PFS	8	8	2, 3 PCLKB	2 ICLK	MPC
0008 C162h	MPC	P42 Pin Function Control Register	P42PFS	8	8	2, 3 PCLKB	2 ICLK	MPC
0008 C163h	MPC	P43 Pin Function Control Register	P43PFS	8	8	2, 3 PCLKB	2 ICLK	MPC
0008 C164h	MPC	P44 Pin Function Control Register	P44PFS	8	8	2, 3 PCLKB	2 ICLK	MPC
0008 C165h	MPC	P45 Pin Function Control Register	P45PFS	8	8	2, 3 PCLKB	2 ICLK	MPC
0008 C166h	MPC	P46 Pin Function Control Register	P46PFS	8	8	2, 3 PCLKB	2 ICLK	MPC
0008 C167h	MPC	P47 Pin Function Control Register	P47PFS	8	8	2, 3 PCLKB	2 ICLK	MPC
0008 C168h	MPC	P50 Pin Function Control Register	P50PFS	8	8	2, 3 PCLKB	2 ICLK	MPC
0008 C169h	MPC	P51 Pin Function Control Register	P51PFS	8	8	2, 3 PCLKB	2 ICLK	MPC
0008 C16Ah	MPC	P52 Pin Function Control Register	P52PFS	8	8	2, 3 PCLKB	2 ICLK	MPC
0008 C16Ch	MPC	P54 Pin Function Control Register	P54PFS	8	8	2, 3 PCLKB	2 ICLK	MPC
0008 C16Dh	MPC	P55 Pin Function Control Register	P55PFS	8	8	2, 3 PCLKB	2 ICLK	MPC
0008 C16Eh	MPC	P56 Pin Function Control Register	P56PFS	8	8	2, 3 PCLKB	2 ICLK	MPC
0008 C170h	MPC	P60 Pin Function Control Register	P60PFS	8	8	2, 3 PCLKB	2 ICLK	MPC
0008 C176h	MPC	P66 Pin Function Control Register	P66PFS	8	8	2, 3 PCLKB	2 ICLK	MPC
0008 C177h	MPC	P67 Pin Function Control Register	P67PFS	8	8	2, 3 PCLKB	2 ICLK	MPC
0008 C179h	MPC	P71 Pin Function Control Register	P71PFS	8	8	2, 3 PCLKB	2 ICLK	MPC
0008 C17Ah	MPC	P72 Pin Function Control Register	P72PFS	8	8	2, 3 PCLKB	2 ICLK	MPC
0008 C17Bh	MPC	P73 Pin Function Control Register	P73PFS	8	8	2, 3 PCLKB	2 ICLK	MPC
0008 C17Ch	MPC	P74 Pin Function Control Register	P74PFS	8	8	2, 3 PCLKB	2 ICLK	MPC
0008 C17Dh	MPC	P75 Pin Function Control Register	P75PFS	8	8	2, 3 PCLKB	2 ICLK	MPC
0008 C17Eh	MPC	P76 Pin Function Control Register	P76PFS	8	8	2, 3 PCLKB	2 ICLK	MPC
0008 C17Fh	MPC	P77 Pin Function Control Register	P77PFS	8	8	2, 3 PCLKB	2 ICLK	MPC
0008 C180h	MPC	P80 Pin Function Control Register	P80PFS	8	8	2, 3 PCLKB	2 ICLK	MPC
0008 C181h	MPC	P81 Pin Function Control Register	P81PFS	8	8	2, 3 PCLKB	2 ICLK	MPC
0008 C182h	MPC	P82 Pin Function Control Register	P82PFS	8	8	2, 3 PCLKB	2 ICLK	MPC
0008 C183h	MPC	P83 Pin Function Control Register	P83PFS	8	8	2, 3 PCLKB	2 ICLK	MPC
0008 C186h	MPC	P86 Pin Function Control Register	P86PFS	8	8	2, 3 PCLKB	2 ICLK	MPC
0008 C187h	MPC	P87 Pin Function Control Register	P87PFS	8	8	2, 3 PCLKB	2 ICLK	MPC
0008 C188h	MPC	P90 Pin Function Control Register	P90PFS	8	8	2, 3 PCLKB	2 ICLK	MPC
0008 C189h	MPC	P91 Pin Function Control Register	P91PFS	8	8	2, 3 PCLKB	2 ICLK	MPC
0008 C18Ah	MPC	P92 Pin Function Control Register	P92PFS	8	8	2, 3 PCLKB	2 ICLK	MPC
0008 C18Bh	MPC	P93 Pin Function Control Register	P93PFS	8	8	2, 3 PCLKB	2 ICLK	MPC
0008 C18Ch	MPC	P94 Pin Function Control Register	P94PFS	8	8	2, 3 PCLKB	2 ICLK	MPC
0008 C18Dh	MPC	P95 Pin Function Control Register	P95PFS	8	8	2, 3 PCLKB	2 ICLK	MPC
0008 C18Eh	MPC	P96 Pin Function Control Register	P96PFS	8	8	2, 3 PCLKB	2 ICLK	MPC
0008 C18Fh	MPC	P97 Pin Function Control Register	P97PFS	8	8	2, 3 PCLKB	2 ICLK	MPC
0008 C190h	MPC	PA0 Pin Function Control Register	PA0PFS	8	8	2, 3 PCLKB	2 ICLK	MPC
0008 C191h	MPC	PA1 Pin Function Control Register	PA1PFS	8	8	2, 3 PCLKB	2 ICLK	MPC
0008 C192h	MPC	PA2 Pin Function Control Register	PA2PFS	8	8	2, 3 PCLKB	2 ICLK	MPC
0008 C193h	MPC	PA3 Pin Function Control Register	PA3PFS	8	8	2, 3 PCLKB	2 ICLK	MPC
0008 C194h	MPC	PA4 Pin Function Control Register	PA4PFS	8	8	2, 3 PCLKB	2 ICLK	MPC

Table 4.1 List of I/O Registers (Address Order) (36 / 70)

Address	Module Symbol	Register Name	Register Symbol	Number of Bits	Access Size	Number of Access Cycles		Related Function
						ICLK ≥ PCLK	ICLK < PCLK	
0008 C195h	MPC	PA5 Pin Function Control Register	PA5PFS	8	8	2, 3 PCLKB	2 ICLK	MPC
0008 C196h	MPC	PA6 Pin Function Control Register	PA6PFS	8	8	2, 3 PCLKB	2 ICLK	MPC
0008 C197h	MPC	PA7 Pin Function Control Register	PA7PFS	8	8	2, 3 PCLKB	2 ICLK	MPC
0008 C198h	MPC	PB0 Pin Function Control Register	PB0PFS	8	8	2, 3 PCLKB	2 ICLK	MPC
0008 C199h	MPC	PB1 Pin Function Control Register	PB1PFS	8	8	2, 3 PCLKB	2 ICLK	MPC
0008 C19Ah	MPC	PB2 Pin Function Control Register	PB2PFS	8	8	2, 3 PCLKB	2 ICLK	MPC
0008 C19Bh	MPC	PB3 Pin Function Control Register	PB3PFS	8	8	2, 3 PCLKB	2 ICLK	MPC
0008 C19Ch	MPC	PB4 Pin Function Control Register	PB4PFS	8	8	2, 3 PCLKB	2 ICLK	MPC
0008 C19Dh	MPC	PB5 Pin Function Control Register	PB5PFS	8	8	2, 3 PCLKB	2 ICLK	MPC
0008 C19Eh	MPC	PB6 Pin Function Control Register	PB6PFS	8	8	2, 3 PCLKB	2 ICLK	MPC
0008 C19Fh	MPC	PB7 Pin Function Control Register	PB7PFS	8	8	2, 3 PCLKB	2 ICLK	MPC
0008 C1A0h	MPC	PC0 Pin Function Control Register	PC0PFS	8	8	2, 3 PCLKB	2 ICLK	MPC
0008 C1A1h	MPC	PC1 Pin Function Control Register	PC1PFS	8	8	2, 3 PCLKB	2 ICLK	MPC
0008 C1A2h	MPC	PC2 Pin Function Control Register	PC2PFS	8	8	2, 3 PCLKB	2 ICLK	MPC
0008 C1A3h	MPC	PC3 Pin Function Control Register	PC3PFS	8	8	2, 3 PCLKB	2 ICLK	MPC
0008 C1A4h	MPC	PC4 Pin Function Control Register	PC4PFS	8	8	2, 3 PCLKB	2 ICLK	MPC
0008 C1A5h	MPC	PC5 Pin Function Control Register	PC5PFS	8	8	2, 3 PCLKB	2 ICLK	MPC
0008 C1A6h	MPC	PC6 Pin Function Control Register	PC6PFS	8	8	2, 3 PCLKB	2 ICLK	MPC
0008 C1A7h	MPC	PC7 Pin Function Control Register	PC7PFS	8	8	2, 3 PCLKB	2 ICLK	MPC
0008 C1A8h	MPC	PD0 Pin Function Control Register	PD0PFS	8	8	2, 3 PCLKB	2 ICLK	MPC
0008 C1A9h	MPC	PD1 Pin Function Control Register	PD1PFS	8	8	2, 3 PCLKB	2 ICLK	MPC
0008 C1AAh	MPC	PD2 Pin Function Control Register	PD2PFS	8	8	2, 3 PCLKB	2 ICLK	MPC
0008 C1ABh	MPC	PD3 Pin Function Control Register	PD3PFS	8	8	2, 3 PCLKB	2 ICLK	MPC
0008 C1ACh	MPC	PD4 Pin Function Control Register	PD4PFS	8	8	2, 3 PCLKB	2 ICLK	MPC
0008 C1ADh	MPC	PD5 Pin Function Control Register	PD5PFS	8	8	2, 3 PCLKB	2 ICLK	MPC
0008 C1AEh	MPC	PD6 Pin Function Control Register	PD6PFS	8	8	2, 3 PCLKB	2 ICLK	MPC
0008 C1AFh	MPC	PD7 Pin Function Control Register	PD7PFS	8	8	2, 3 PCLKB	2 ICLK	MPC
0008 C1B0h	MPC	PE0 Pin Function Control Register	PE0PFS	8	8	2, 3 PCLKB	2 ICLK	MPC
0008 C1B1h	MPC	PE1 Pin Function Control Register	PE1PFS	8	8	2, 3 PCLKB	2 ICLK	MPC
0008 C1B2h	MPC	PE2 Pin Function Control Register	PE2PFS	8	8	2, 3 PCLKB	2 ICLK	MPC
0008 C1B3h	MPC	PE3 Pin Function Control Register	PE3PFS	8	8	2, 3 PCLKB	2 ICLK	MPC
0008 C1B4h	MPC	PE4 Pin Function Control Register	PE4PFS	8	8	2, 3 PCLKB	2 ICLK	MPC
0008 C1B5h	MPC	PE5 Pin Function Control Register	PE5PFS	8	8	2, 3 PCLKB	2 ICLK	MPC
0008 C1B6h	MPC	PE6 Pin Function Control Register	PE6PFS	8	8	2, 3 PCLKB	2 ICLK	MPC
0008 C1B7h	MPC	PE7 Pin Function Control Register	PE7PFS	8	8	2, 3 PCLKB	2 ICLK	MPC
0008 C1B8h	MPC	PF0 Pin Function Control Register	PF0PFS	8	8	2, 3 PCLKB	2 ICLK	MPC
0008 C1B9h	MPC	PF1 Pin Function Control Register	PF1PFS	8	8	2, 3 PCLKB	2 ICLK	MPC
0008 C1BAh	MPC	PF2 Pin Function Control Register	PF2PFS	8	8	2, 3 PCLKB	2 ICLK	MPC
0008 C1BDh	MPC	PF5 Pin Function Control Register	PF5PFS	8	8	2, 3 PCLKB	2 ICLK	MPC
0008 C1C0h	MPC	PG0 Pin Function Control Register	PG0PFS	8	8	2, 3 PCLKB	2 ICLK	MPC
0008 C1C1h	MPC	PG1 Pin Function Control Register	PG1PFS	8	8	2, 3 PCLKB	2 ICLK	MPC
0008 C1C2h	MPC	PG2 Pin Function Control Register	PG2PFS	8	8	2, 3 PCLKB	2 ICLK	MPC
0008 C1C3h	MPC	PG3 Pin Function Control Register	PG3PFS	8	8	2, 3 PCLKB	2 ICLK	MPC
0008 C1C4h	MPC	PG4 Pin Function Control Register	PG4PFS	8	8	2, 3 PCLKB	2 ICLK	MPC
0008 C1C5h	MPC	PG5 Pin Function Control Register	PG5PFS	8	8	2, 3 PCLKB	2 ICLK	MPC
0008 C1C6h	MPC	PG6 Pin Function Control Register	PG6PFS	8	8	2, 3 PCLKB	2 ICLK	MPC
0008 C1C7h	MPC	PG7 Pin Function Control Register	PG7PFS	8	8	2, 3 PCLKB	2 ICLK	MPC
0008 C1D3h	MPC	PJ3 Pin Function Control Register	PJ3PFS	8	8	2, 3 PCLKB	2 ICLK	MPC
0008 C1D5h	MPC	PJ5 Pin Function Control Register	PJ5PFS	8	8	2, 3 PCLKB	2 ICLK	MPC

Table 4.1 List of I/O Registers (Address Order) (37 / 70)

Address	Module Symbol	Register Name	Register Symbol	Number of Bits	Access Size	Number of Access Cycles		Related Function
						ICLK ≥ PCLK	ICLK < PCLK	
0008 C280h	SYSTEM	Deep Standby Control Register	DPSBYCR	8	8	4, 5 PCLKB	2, 3 ICLK	Low Power Consumption
0008 C282h	SYSTEM	Deep Standby Interrupt Enable Register 0	DPSIER0	8	8	4, 5 PCLKB	2, 3 ICLK	Low Power Consumption
0008 C283h	SYSTEM	Deep Standby Interrupt Enable Register 1	DPSIER1	8	8	4, 5 PCLKB	2, 3 ICLK	Low Power Consumption
0008 C284h	SYSTEM	Deep Standby Interrupt Enable Register 2	DPSIER2	8	8	4, 5 PCLKB	2, 3 ICLK	Low Power Consumption
0008 C285h	SYSTEM	Deep Standby Interrupt Enable Register 3	DPSIER3	8	8	4, 5 PCLKB	2, 3 ICLK	Low Power Consumption
0008 C286h	SYSTEM	Deep Standby Interrupt Flag Register 0	DPSIFR0	8	8	4, 5 PCLKB	2, 3 ICLK	Low Power Consumption
0008 C287h	SYSTEM	Deep Standby Interrupt Flag Register 1	DPSIFR1	8	8	4, 5 PCLKB	2, 3 ICLK	Low Power Consumption
0008 C288h	SYSTEM	Deep Standby Interrupt Flag Register 2	DPSIFR2	8	8	4, 5 PCLKB	2, 3 ICLK	Low Power Consumption
0008 C289h	SYSTEM	Deep Standby Interrupt Flag Register 3	DPSIFR3	8	8	4, 5 PCLKB	2, 3 ICLK	Low Power Consumption
0008 C28Ah	SYSTEM	Deep Standby Interrupt Edge Register 0	DPSIEGR0	8	8	4, 5 PCLKB	2, 3 ICLK	Low Power Consumption
0008 C28Bh	SYSTEM	Deep Standby Interrupt Edge Register 1	DPSIEGR1	8	8	4, 5 PCLKB	2, 3 ICLK	Low Power Consumption
0008 C28Ch	SYSTEM	Deep Standby Interrupt Edge Register 2	DPSIEGR2	8	8	4, 5 PCLKB	2, 3 ICLK	Low Power Consumption
0008 C28Dh	SYSTEM	Deep Standby Interrupt Edge Register 3	DPSIEGR3	8	8	4, 5 PCLKB	2, 3 ICLK	Low Power Consumption
0008 C290h	SYSTEM	Reset Status Register 0	RSTSR0	8	8	4, 5 PCLKB	2, 3 ICLK	Resets
0008 C291h	SYSTEM	Reset Status Register 1	RSTSR1	8	8	4, 5 PCLKB	2, 3 ICLK	Resets
0008 C293h	SYSTEM	Main Clock Oscillator Forced Oscillation Control Register	MOFCR	8	8	4, 5 PCLKB	2, 3 ICLK	Clock Generation Circuit
0008 C294h	SYSTEM	High-Speed On-Chip Oscillator Power Supply Control Register	HOCOPCR	8	8	4, 5 PCLKB	2, 3 ICLK	Clock Generation Circuit
0008 C296h	FLASH	Flash P/E Protect Register	FWEPROR	8	8	2 ICLK		Flash
0008 C297h	SYSTEM	Voltage Monitoring Circuit Control Register	LVCMPCR	8	8	4, 5 PCLKB	2, 3 ICLK	LVDA
0008 C298h	SYSTEM	Voltage Detection Level Select Register	LVDLVL	8	8	4, 5 PCLKB	2, 3 ICLK	LVDA
0008 C29Ah	SYSTEM	Voltage Monitoring 1 Circuit Control Register 0	LVD1CR0	8	8	4, 5 PCLKB	2, 3 ICLK	LVDA

Table 4.1 List of I/O Registers (Address Order) (38 / 70)

Address	Module Symbol	Register Name	Register Symbol	Number of Bits	Access Size	Number of Access Cycles		Related Function
						ICLK ≥ PCLK	ICLK < PCLK	
0008 C29Bh	SYSTEM	Voltage Monitoring 2 Circuit Control Register 0	LVD2CR0	8	8	4, 5 PCLKB	2, 3 ICLK	LVDA
0008 C2A0h to 0008 C2BFh	SYSTEM	Deep Standby Backup Register 0 to Deep Standby Backup Register 31	DPSBKR0 to DPSBKR31	8	8	4, 5 PCLKB	2, 3 ICLK	Low Power Consumption
0008 C400h	RTC	64-Hz Counter	R64CNT	8	8	2, 3 PCLKB	2 ICLK	RTCd
0008 C402h	RTC	Second Counter	RSECCNT	8	8	2, 3 PCLKB	2 ICLK	RTCd
0008 C402h	RTC	Binary Counter 0	BCNT0	8	8	2, 3 PCLKB	2 ICLK	RTCd
0008 C404h	RTC	Minute Counter	RMINCNT	8	8	2, 3 PCLKB	2 ICLK	RTCd
0008 C404h	RTC	Binary Counter 1	BCNT1	8	8	2, 3 PCLKB	2 ICLK	RTCd
0008 C406h	RTC	Hour Counter	RHRCNT	8	8	2, 3 PCLKB	2 ICLK	RTCd
0008 C406h	RTC	Binary Counter 2	BCNT2	8	8	2, 3 PCLKB	2 ICLK	RTCd
0008 C408h	RTC	Day-of-Week Counter	RWKCNT	8	8	2, 3 PCLKB	2 ICLK	RTCd
0008 C408h	RTC	Binary Counter 3	BCNT3	8	8	2, 3 PCLKB	2 ICLK	RTCd
0008 C40Ah	RTC	Date Counter	RDAYCNT	8	8	2, 3 PCLKB	2 ICLK	RTCd
0008 C40Ch	RTC	Month Counter	RMONCNT	8	8	2, 3 PCLKB	2 ICLK	RTCd
0008 C40Eh	RTC	Year Counter	RYRCNT	16	16	2, 3 PCLKB	2 ICLK	RTCd
0008 C410h	RTC	Second Alarm Register	RSECAR	8	8	2, 3 PCLKB	2 ICLK	RTCd
0008 C410h	RTC	Binary Counter 0 Alarm Register	BCNT0AR	8	8	2, 3 PCLKB	2 ICLK	RTCd
0008 C412h	RTC	Minute Alarm Register	RMINAR	8	8	2, 3 PCLKB	2 ICLK	RTCd
0008 C412h	RTC	Binary Counter 1 Alarm Register	BCNT1AR	8	8	2, 3 PCLKB	2 ICLK	RTCd
0008 C414h	RTC	Hour Alarm Register	RHRAR	8	8	2, 3 PCLKB	2 ICLK	RTCd
0008 C414h	RTC	Binary Counter 2 Alarm Register	BCNT2AR	8	8	2, 3 PCLKB	2 ICLK	RTCd
0008 C416h	RTC	Day-of-Week Alarm Register	RWKAR	8	8	2, 3 PCLKB	2 ICLK	RTCd
0008 C416h	RTC	Binary Counter 3 Alarm Register	BCNT3AR	8	8	2, 3 PCLKB	2 ICLK	RTCd
0008 C418h	RTC	Date Alarm Register	RDAYAR	8	8	2, 3 PCLKB	2 ICLK	RTCd
0008 C418h	RTC	Binary Counter 0 Alarm Enable Register	BCNT0AER	8	8	2, 3 PCLKB	2 ICLK	RTCd
0008 C41Ah	RTC	Month Alarm Register	RMONAR	8	8	2, 3 PCLKB	2 ICLK	RTCd
0008 C41Ah	RTC	Binary Counter 1 Alarm Enable Register	BCNT1AER	8	8	2, 3 PCLKB	2 ICLK	RTCd
0008 C41Ch	RTC	Year Alarm Register	RYRAR	16	16	2, 3 PCLKB	2 ICLK	RTCd
0008 C41Ch	RTC	Binary Counter 2 Alarm Enable Register	BCNT2AER	16	16	2, 3 PCLKB	2 ICLK	RTCd
0008 C41Eh	RTC	Year Alarm Enable Register	RYRAREN	8	8	2, 3 PCLKB	2 ICLK	RTCd
0008 C41Eh	RTC	Binary Counter 3 Alarm Enable Register	BCNT3AER	8	8	2, 3 PCLKB	2 ICLK	RTCd
0008 C422h	RTC	RTC Control Register 1	RCR1	8	8	2, 3 PCLKB	2 ICLK	RTCd
0008 C424h	RTC	RTC Control Register 2	RCR2	8	8	2, 3 PCLKB	2 ICLK	RTCd
0008 C426h	RTC	RTC Control Register 3	RCR3	8	8	2, 3 PCLKB	2 ICLK	RTCd
0008 C428h	RTC	RTC Control Register 4	RCR4	8	8	2, 3 PCLKB	2 ICLK	RTCd
0008 C42Ah	RTC	Frequency Register H	RFRH	16	16	2, 3 PCLKB	2 ICLK	RTCd
0008 C42Ch	RTC	Frequency Register L	RFRL	16	16	2, 3 PCLKB	2 ICLK	RTCd
0008 C42Eh	RTC	Time Error Adjustment Register	RADJ	8	8	2, 3 PCLKB	2 ICLK	RTCd
0008 C440h	RTC	Time Capture Control Register 0	RTCCR0	8	8	2, 3 PCLKB	2 ICLK	RTCd
0008 C442h	RTC	Time Capture Control Register 1	RTCCR1	8	8	2, 3 PCLKB	2 ICLK	RTCd
0008 C444h	RTC	Time Capture Control Register 2	RTCCR2	8	8	2, 3 PCLKB	2 ICLK	RTCd
0008 C452h	RTC	Second Capture Register 0	RSECCP0	8	8	2, 3 PCLKB	2 ICLK	RTCd
0008 C452h	RTC	BCNT0 Capture Register 0	BCNT0CP0	8	8	2, 3 PCLKB	2 ICLK	RTCd
0008 C454h	RTC	Minute Capture Register 0	RMINCP0	8	8	2, 3 PCLKB	2 ICLK	RTCd
0008 C454h	RTC	BCNT1 Capture Register 0	BCNT1CP0	8	8	2, 3 PCLKB	2 ICLK	RTCd
0008 C456h	RTC	Hour Capture Register 0	RHRCP0	8	8	2, 3 PCLKB	2 ICLK	RTCd
0008 C456h	RTC	BCNT2 Capture Register 0	BCNT2CP0	8	8	2, 3 PCLKB	2 ICLK	RTCd
0008 C45Ah	RTC	Date Capture Register 0	RDAYCP0	8	8	2, 3 PCLKB	2 ICLK	RTCd

Table 4.1 List of I/O Registers (Address Order) (39 / 70)

Address	Module Symbol	Register Name	Register Symbol	Number of Bits	Access Size	Number of Access Cycles		Related Function
						ICLK ≥ PCLK	ICLK < PCLK	
0008 C45Ah	RTC	BCNT3 Capture Register 0	BCNT3CP0	8	8	2, 3 PCLKB	2 ICLK	RTCd
0008 C45Ch	RTC	Month Capture Register 0	RMONCP0	8	8	2, 3 PCLKB	2 ICLK	RTCd
0008 C462h	RTC	Second Capture Register 1	RSECCP1	8	8	2, 3 PCLKB	2 ICLK	RTCd
0008 C462h	RTC	BCNT0 Capture Register 1	BCNT0CP1	8	8	2, 3 PCLKB	2 ICLK	RTCd
0008 C464h	RTC	Minute Capture Register 1	RMINCP1	8	8	2, 3 PCLKB	2 ICLK	RTCd
0008 C464h	RTC	BCNT1 Capture Register 1	BCNT1CP1	8	8	2, 3 PCLKB	2 ICLK	RTCd
0008 C466h	RTC	Hour Capture Register 1	RHRCP1	8	8	2, 3 PCLKB	2 ICLK	RTCd
0008 C466h	RTC	BCNT2 Capture Register 1	BCNT2CP1	8	8	2, 3 PCLKB	2 ICLK	RTCd
0008 C46Ah	RTC	Date Capture Register 1	RDAYCP1	8	8	2, 3 PCLKB	2 ICLK	RTCd
0008 C46Ah	RTC	BCNT3 Capture Register 1	BCNT3CP1	8	8	2, 3 PCLKB	2 ICLK	RTCd
0008 C46Ch	RTC	Month Capture Register 1	RMONCP1	8	8	2, 3 PCLKB	2 ICLK	RTCd
0008 C472h	RTC	Second Capture Register 2	RSECCP2	8	8	2, 3 PCLKB	2 ICLK	RTCd
0008 C472h	RTC	BCNT0 Capture Register 2	BCNT0CP2	8	8	2, 3 PCLKB	2 ICLK	RTCd
0008 C474h	RTC	Minute Capture Register 2	RMINCP2	8	8	2, 3 PCLKB	2 ICLK	RTCd
0008 C474h	RTC	BCNT1 Capture Register 2	BCNT1CP2	8	8	2, 3 PCLKB	2 ICLK	RTCd
0008 C476h	RTC	Hour Capture Register 2	RHRCP2	8	8	2, 3 PCLKB	2 ICLK	RTCd
0008 C476h	RTC	BCNT2 Capture Register 2	BCNT2CP2	8	8	2, 3 PCLKB	2 ICLK	RTCd
0008 C47Ah	RTC	Date Capture Register 2	RDAYCP2	8	8	2, 3 PCLKB	2 ICLK	RTCd
0008 C47Ah	RTC	BCNT3 Capture Register 2	BCNT3CP2	8	8	2, 3 PCLKB	2 ICLK	RTCd
0008 C47Ch	RTC	Month Capture Register 2	RMONCP2	8	8	2, 3 PCLKB	2 ICLK	RTCd
0008 C4C0h	POE3	Input Level Control/Status Register 1	ICSR1	16	16	2, 3 PCLKB	2 ICLK	POE3
0008 C4C2h	POE3	Output Level Control/Status Register 1	OCSR1	16	16	2, 3 PCLKB	2 ICLK	POE3
0008 C4C4h	POE3	Input Level Control/Status Register 2	ICSR2	16	16	2, 3 PCLKB	2 ICLK	POE3
0008 C4C6h	POE3	Output Level Control/Status Register 2	OCSR2	16	16	2, 3 PCLKB	2 ICLK	POE3
0008 C4C8h	POE3	Input Level Control/Status Register 3	ICSR3	16	16	2, 3 PCLKB	2 ICLK	POE3
0008 C4CAh	POE3	Software Port Output Enable Register	SPOER	8	8	2, 3 PCLKB	2 ICLK	POE3
0008 C4CBh	POE3	Port Output Enable Control Register 1	POECR1	8	8	2, 3 PCLKB	2 ICLK	POE3
0008 C4CCh	POE3	Port Output Enable Control Register 2	POECR2	16	16	2, 3 PCLKB	2 ICLK	POE3
0008 C4CEh	POE3	Port Output Enable Control Register 3	POECR3	16	16	2, 3 PCLKB	2 ICLK	POE3
0008 C4D0h	POE3	Port Output Enable Control Register 4	POECR4	16	16	2, 3 PCLKB	2 ICLK	POE3
0008 C4D2h	POE3	Port Output Enable Control Register 5	POECR5	16	16	2, 3 PCLKB	2 ICLK	POE3
0008 C4D4h	POE3	Port Output Enable Control Register 6	POECR6	16	16	2, 3 PCLKB	2 ICLK	POE3
0008 C4D6h	POE3	Input Level Control/Status Register 4	ICSR4	16	16	2, 3 PCLKB	2 ICLK	POE3
0008 C4D8h	POE3	Input Level Control/Status Register 5	ICSR5	16	16	2, 3 PCLKB	2 ICLK	POE3
0008 C4DAh	POE3	Active Level Setting Register 1	ALR1	16	16	2, 3 PCLKB	2 ICLK	POE3
0008 C4DCh	POE3	Input Level Control/Status Register 6	ICSR6	16	16	2, 3 PCLKB	2 ICLK	POE3
0008 C4E0h	POE3	GPT0 Pin Select Register	G0SELR	8	8	2, 3 PCLKB	2 ICLK	POE3
0008 C4E1h	POE3	GPT1 Pin Select Register	G1SELR	8	8	2, 3 PCLKB	2 ICLK	POE3
0008 C4E2h	POE3	GPT2 Pin Select Register	G2SELR	8	8	2, 3 PCLKB	2 ICLK	POE3
0008 C4E3h	POE3	GPT3 Pin Select Register	G3SELR	8	8	2, 3 PCLKB	2 ICLK	POE3
0008 C4E4h	POE3	MTU0 Pin Select Register 1	M0SELR1	8	8	2, 3 PCLKB	2 ICLK	POE3
0008 C4E5h	POE3	MTU0 Pin Select Register 2	M0SELR2	8	8	2, 3 PCLKB	2 ICLK	POE3
0008 C4E6h	POE3	MTU3 Pin Select Register	M3SELR	8	8	2, 3 PCLKB	2 ICLK	POE3
0008 C4E7h	POE3	MTU4 Pin Select Register 1	M4SELR1	8	8	2, 3 PCLKB	2 ICLK	POE3
0008 C4E8h	POE3	MTU4 Pin Select Register 2	M4SELR2	8	8	2, 3 PCLKB	2 ICLK	POE3
0008 C4E9h	POE3	MTU/GPT Pin Select Register	MGSELR	8	8	2, 3 PCLKB	2 ICLK	POE3
0008 C500h	TEMPS	Temperature Sensor Control Register	TSCR	8	8	2, 3 PCLKB	2 ICLK	TEMPS
0008 C5C0h	DA	D/A A/D Synchronous Unit Select Register	DAADUSR	8	8	2, 3 PCLKB	2 ICLK	R12DA
0009 0200h to 0009 03FFh	CAN0	Mailbox Register 0 to Mailbox Register 31	MB0 to MB31	128	8, 16, 32*6	2, 3 PCLKB	2 ICLK	CAN

Table 4.1 List of I/O Registers (Address Order) (40 / 70)

Address	Module Symbol	Register Name	Register Symbol	Number of Bits	Access Size	Number of Access Cycles		Related Function
						ICLK ≥ PCLK	ICLK < PCLK	
0009 0400h to 0009 041Fh	CAN0	Mask Register 0 to Mask Register 7	MKR0 to MKR7	32	8, 16, 32	2, 3 PCLKB	2 ICLK	CAN
0009 0420h	CAN0	FIFO Received ID Compare Register 0	FIDCR0	32	8, 16, 32	2, 3 PCLKB	2 ICLK	CAN
0009 0424h	CAN0	FIFO Received ID Compare Register 1	FIDCR1	32	8, 16, 32	2, 3 PCLKB	2 ICLK	CAN
0009 0428h	CAN0	Mask Invalid Register	MKIVLR	32	8, 16, 32	2, 3 PCLKB	2 ICLK	CAN
0009 042Ch	CAN0	Mailbox Interrupt Enable Register	MIER	32	8, 16, 32	2, 3 PCLKB	2 ICLK	CAN
0009 0820h to 0009 083Fh	CAN0	Message Control Register 0 to Message Control Register 31	MCTL0 to MCTL31	8	8	2, 3 PCLKB	2 ICLK	CAN
0009 0840h	CAN0	Control Register	CTLR	16	8, 16	2, 3 PCLKB	2 ICLK	CAN
0009 0842h	CAN0	Status Register	STR	16	8, 16	2, 3 PCLKB	2 ICLK	CAN
0009 0844h	CAN0	Bit Configuration Register	BCR	32	8, 16, 32	2, 3 PCLKB	2 ICLK	CAN
0009 0848h	CAN0	Receive FIFO Control Register	RFCR	8	8	2, 3 PCLKB	2 ICLK	CAN
0009 0849h	CAN0	Receive FIFO Pointer Control Register	RFPCR	8	8	2, 3 PCLKB	2 ICLK	CAN
0009 084Ah	CAN0	Transmit FIFO Control Register	TFCR	8	8	2, 3 PCLKB	2 ICLK	CAN
0009 084Bh	CAN0	Transmit FIFO Pointer Control Register	TFPCR	8	8	2, 3 PCLKB	2 ICLK	CAN
0009 084Ch	CAN0	Error Interrupt Enable Register	EIER	8	8	2, 3 PCLKB	2 ICLK	CAN
0009 084Dh	CAN0	Error Interrupt Factor Judge Register	EIFR	8	8	2, 3 PCLKB	2 ICLK	CAN
0009 084Eh	CAN0	Receive Error Count Register	RECR	8	8	2, 3 PCLKB	2 ICLK	CAN
0009 084Fh	CAN0	Transmit Error Count Register	TECR	8	8	2, 3 PCLKB	2 ICLK	CAN
0009 0850h	CAN0	Error Code Store Register	ECSR	8	8	2, 3 PCLKB	2 ICLK	CAN
0009 0851h	CAN0	Channel Search Support Register	CSSR	8	8	2, 3 PCLKB	2 ICLK	CAN
0009 0852h	CAN0	Mailbox Search Status Register	MSSR	8	8	2, 3 PCLKB	2 ICLK	CAN
0009 0853h	CAN0	Mailbox Search Mode Register	MSMR	8	8	2, 3 PCLKB	2 ICLK	CAN
0009 0854h	CAN0	Time Stamp Register	TSR	16	16	2, 3 PCLKB	2 ICLK	CAN
0009 0856h	CAN0	Acceptance Filter Support Register	AFSR	16	8, 16	2, 3 PCLKB	2 ICLK	CAN
0009 0858h	CAN0	Test Control Register	TCR	8	8	2, 3 PCLKB	2 ICLK	CAN
0009 1200h to 0009 13FFh	CAN1	Mailbox Register 0 to Mailbox Register 31	MB0 to MB31	128	8, 16, 32*6	2, 3 PCLKB	2 ICLK	CAN
0009 1400h to 0009 141Fh	CAN1	Mask Register 0 to Mask Register 7	MKR0 to MKR7	32	8, 16, 32	2, 3 PCLKB	2 ICLK	CAN
0009 1420h	CAN1	FIFO Received ID Compare Register 0	FIDCR0	32	8, 16, 32	2, 3 PCLKB	2 ICLK	CAN
0009 1424h	CAN1	FIFO Received ID Compare Register 1	FIDCR1	32	8, 16, 32	2, 3 PCLKB	2 ICLK	CAN
0009 1428h	CAN1	Mask Invalid Register	MKIVLR	32	8, 16, 32	2, 3 PCLKB	2 ICLK	CAN
0009 142Ch	CAN1	Mailbox Interrupt Enable Register	MIER	32	8, 16, 32	2, 3 PCLKB	2 ICLK	CAN
0009 1820h to 0009 183Fh	CAN1	Message Control Register 0 to Message Control Register 31	MCTL0 to MCTL31	8	8	2, 3 PCLKB	2 ICLK	CAN
0009 1840h	CAN1	Control Register	CTLR	16	8, 16	2, 3 PCLKB	2 ICLK	CAN
0009 1842h	CAN1	Status Register	STR	16	8, 16	2, 3 PCLKB	2 ICLK	CAN
0009 1844h	CAN1	Bit Configuration Register	BCR	32	8, 16, 32	2, 3 PCLKB	2 ICLK	CAN
0009 1848h	CAN1	Receive FIFO Control Register	RFCR	8	8	2, 3 PCLKB	2 ICLK	CAN
0009 1849h	CAN1	Receive FIFO Pointer Control Register	RFPCR	8	8	2, 3 PCLKB	2 ICLK	CAN
0009 184Ah	CAN1	Transmit FIFO Control Register	TFCR	8	8	2, 3 PCLKB	2 ICLK	CAN
0009 184Bh	CAN1	Transmit FIFO Pointer Control Register	TFPCR	8	8	2, 3 PCLKB	2 ICLK	CAN
0009 184Ch	CAN1	Error Interrupt Enable Register	EIER	8	8	2, 3 PCLKB	2 ICLK	CAN
0009 184Dh	CAN1	Error Interrupt Factor Judge Register	EIFR	8	8	2, 3 PCLKB	2 ICLK	CAN
0009 184Eh	CAN1	Receive Error Count Register	RECR	8	8	2, 3 PCLKB	2 ICLK	CAN
0009 184Fh	CAN1	Transmit Error Count Register	TECR	8	8	2, 3 PCLKB	2 ICLK	CAN
0009 1850h	CAN1	Error Code Store Register	ECSR	8	8	2, 3 PCLKB	2 ICLK	CAN

Table 4.1 List of I/O Registers (Address Order) (41 / 70)

Address	Module Symbol	Register Name	Register Symbol	Number of Bits	Access Size	Number of Access Cycles		Related Function
						ICLK ≥ PCLK	ICLK < PCLK	
0009 1851h	CAN1	Channel Search Support Register	CSSR	8	8	2, 3 PCLKB	2 ICLK	CAN
0009 1852h	CAN1	Mailbox Search Status Register	MSSR	8	8	2, 3 PCLKB	2 ICLK	CAN
0009 1853h	CAN1	Mailbox Search Mode Register	MSMR	8	8	2, 3 PCLKB	2 ICLK	CAN
0009 1854h	CAN1	Time Stamp Register	TSR	16	16	2, 3 PCLKB	2 ICLK	CAN
0009 1856h	CAN1	Acceptance Filter Support Register	AFSR	16	8, 16	2, 3 PCLKB	2 ICLK	CAN
0009 1858h	CAN1	Test Control Register	TCR	8	8	2, 3 PCLKB	2 ICLK	CAN
0009 2200h to 0009 23FFh	CAN2	Mailbox Register 0 to Mailbox Register 31	MB0 to MB31	128	8, 16, 32*6	2, 3 PCLKB	2 ICLK	CAN
0009 2400h to 0009 241Fh	CAN2	Mask Register 0 to Mask Register 7	MKR0 to MKR7	32	8, 16, 32	2, 3 PCLKB	2 ICLK	CAN
0009 2420h	CAN2	FIFO Received ID Compare Register 0	FIDCR0	32	8, 16, 32	2, 3 PCLKB	2 ICLK	CAN
0009 2424h	CAN2	FIFO Received ID Compare Register 1	FIDCR1	32	8, 16, 32	2, 3 PCLKB	2 ICLK	CAN
0009 2428h	CAN2	Mask Invalid Register	MKIVLR	32	8, 16, 32	2, 3 PCLKB	2 ICLK	CAN
0009 242Ch	CAN2	Mailbox Interrupt Enable Register	MIER	32	8, 16, 32	2, 3 PCLKB	2 ICLK	CAN
0009 2820h to 0009 283Fh	CAN2	Message Control Register 0 to Message Control Register 31	MCTL0 to MCTL31	8	8	2, 3 PCLKB	2 ICLK	CAN
0009 2840h	CAN2	Control Register	CTLR	16	8, 16	2, 3 PCLKB	2 ICLK	CAN
0009 2842h	CAN2	Status Register	STR	16	8, 16	2, 3 PCLKB	2 ICLK	CAN
0009 2844h	CAN2	Bit Configuration Register	BCR	32	8, 16, 32	2, 3 PCLKB	2 ICLK	CAN
0009 2848h	CAN2	Receive FIFO Control Register	RFCR	8	8	2, 3 PCLKB	2 ICLK	CAN
0009 2849h	CAN2	Receive FIFO Pointer Control Register	RFPCR	8	8	2, 3 PCLKB	2 ICLK	CAN
0009 284Ah	CAN2	Transmit FIFO Control Register	TFCR	8	8	2, 3 PCLKB	2 ICLK	CAN
0009 284Bh	CAN2	Transmit FIFO Pointer Control Register	TFPCR	8	8	2, 3 PCLKB	2 ICLK	CAN
0009 284Ch	CAN2	Error Interrupt Enable Register	EIER	8	8	2, 3 PCLKB	2 ICLK	CAN
0009 284Dh	CAN2	Error Interrupt Factor Judge Register	EIFR	8	8	2, 3 PCLKB	2 ICLK	CAN
0009 284Eh	CAN2	Receive Error Count Register	RECR	8	8	2, 3 PCLKB	2 ICLK	CAN
0009 284Fh	CAN2	Transmit Error Count Register	TECR	8	8	2, 3 PCLKB	2 ICLK	CAN
0009 2850h	CAN2	Error Code Store Register	ECSR	8	8	2, 3 PCLKB	2 ICLK	CAN
0009 2851h	CAN2	Channel Search Support Register	CSSR	8	8	2, 3 PCLKB	2 ICLK	CAN
0009 2852h	CAN2	Mailbox Search Status Register	MSSR	8	8	2, 3 PCLKB	2 ICLK	CAN
0009 2853h	CAN2	Mailbox Search Mode Register	MSMR	8	8	2, 3 PCLKB	2 ICLK	CAN
0009 2854h	CAN2	Time Stamp Register	TSR	16	8, 16	2, 3 PCLKB	2 ICLK	CAN
0009 2856h	CAN2	Acceptance Filter Support Register	AFSR	16	8, 16	2, 3 PCLKB	2 ICLK	CAN
0009 2858h	CAN2	Test Control Register	TCR	8	8	2, 3 PCLKB	2 ICLK	CAN
0009 4200h	CMTW0	Timer Start Register	CMWSTR	16	16	2, 3 PCLKB	2 ICLK	CMTW
0009 4204h	CMTW0	Timer Control Register	CMWCR	16	16	2, 3 PCLKB	2 ICLK	CMTW
0009 4208h	CMTW0	Timer I/O Control Register	CMWIOR	16	16	2, 3 PCLKB	2 ICLK	CMTW
0009 4210h	CMTW0	Timer Counter	CMWCNT	32	32	2, 3 PCLKB	2 ICLK	CMTW
0009 4214h	CMTW0	Compare Match Constant Register	CMWCOR	32	32	2, 3 PCLKB	2 ICLK	CMTW
0009 4218h	CMTW0	Input Capture Register 0	CMWICR0	32	32	2, 3 PCLKB	2 ICLK	CMTW
0009 421Ch	CMTW0	Input Capture Register 1	CMWICR1	32	32	2, 3 PCLKB	2 ICLK	CMTW
0009 4220h	CMTW0	Output Compare Register 0	CMWOCR0	32	32	2, 3 PCLKB	2 ICLK	CMTW
0009 4224h	CMTW0	Output Compare Register 1	CMWOCR1	32	32	2, 3 PCLKB	2 ICLK	CMTW
0009 4280h	CMTW1	Timer Start Register	CMWSTR	16	16	2, 3 PCLKB	2 ICLK	CMTW
0009 4284h	CMTW1	Timer Control Register	CMWCR	16	16	2, 3 PCLKB	2 ICLK	CMTW
0009 4288h	CMTW1	Timer I/O Control Register	CMWIOR	16	16	2, 3 PCLKB	2 ICLK	CMTW
0009 4290h	CMTW1	Timer Counter	CMWCNT	32	32	2, 3 PCLKB	2 ICLK	CMTW
0009 4294h	CMTW1	Compare Match Constant Register	CMWCOR	32	32	2, 3 PCLKB	2 ICLK	CMTW
0009 4298h	CMTW1	Input Capture Register 0	CMWICR0	32	32	2, 3 PCLKB	2 ICLK	CMTW

Table 4.1 List of I/O Registers (Address Order) (42 / 70)

Address	Module Symbol	Register Name	Register Symbol	Number of Bits	Access Size	Number of Access Cycles		Related Function
						ICLK ≥ PCLK	ICLK < PCLK	
0009 429Ch	CMTW1	Input Capture Register 1	CMWOCR1	32	32	2, 3 PCLKB	2 ICLK	CMTW
0009 42A0h	CMTW1	Output Compare Register 0	CMWOCR0	32	32	2, 3 PCLKB	2 ICLK	CMTW
0009 42A4h	CMTW1	Output Compare Register 1	CMWOCR1	32	32	2, 3 PCLKB	2 ICLK	CMTW
0009 8000h to 0009 D6BFh	SRC	Filter Coefficient Table 0 to Filter Coefficient Table 5551	SRCFCTR0 to SRCFCTR55 51	32	32	4, 5 PCLKB	2, 3 ICLK	SRC
0009 DFF0h	SRC	Input Data Register	SRCID	32	32	5, 6 PCLKB	2, 3 ICLK	SRC
0009 DFF4h	SRC	Output Data Register	SRCOD	32	32	5, 6 PCLKB	2, 3 ICLK	SRC
0009 DFF8h	SRC	Input Data Control Register	SRCIDCTRL	16	16	4, 5 PCLKB	2, 3 ICLK	SRC
0009 DFFAh	SRC	Output Data Control Register	SRCODCTRL	16	16	4, 5 PCLKB	2, 3 ICLK	SRC
0009 DFFCh	SRC	Control Register	SRCCTRL	16	16	4, 5 PCLKB	2, 3 ICLK	SRC
0009 DFFEh	SRC	Status Register	SRCSTAT	16	16	4, 5 PCLKB	2, 3 ICLK	SRC
000A 0000h	USB0	System Configuration Control Register	SYSCFG	16	16	3, 4 PCLKB	2 ICLK	USBb
000A 0004h	USB0	System Configuration Status Register 0	SYSSTS0	16	16	9 PCLKB or more	Rounded up to the nearest integer greater than $1 + 9 \times (\text{frequency ratio of ICLK/PCLKB})^{*5}$	USBb
000A 0008h	USB0	Device State Control Register 0	DVSTCTR0	16	16	9 PCLKB or more	Rounded up to the nearest integer greater than $1 + 9 \times (\text{frequency ratio of ICLK/PCLKB})^{*5}$	USBb
000A 0014h	USB0	CFIFO Port Register	CFIFO	16	8, 16	3, 4 PCLKB	2 ICLK	USBb
000A 0018h	USB0	D0FIFO Port Register	D0FIFO	16	8, 16	3, 4 PCLKB	2 ICLK	USBb
000A 001Ch	USB0	D1FIFO Port Register	D1FIFO	16	8, 16	3, 4 PCLKB	2 ICLK	USBb
000A 0020h	USB0	CFIFO Port Select Register	CFIFOSEL	16	16	3, 4 PCLKB	2 ICLK	USBb
000A 0022h	USB0	CFIFO Port Control Register	CFIFOCTR	16	16	3, 4 PCLKB	2 ICLK	USBb
000A 0028h	USB0	D0FIFO Port Select Register	D0FIFOSEL	16	16	3, 4 PCLKB	2 ICLK	USBb
000A 002Ah	USB0	D0FIFO Port Control Register	D0FIFOCTR	16	16	3, 4 PCLKB	2 ICLK	USBb
000A 002Ch	USB0	D1FIFO Port Select Register	D1FIFOSEL	16	16	3, 4 PCLKB	2 ICLK	USBb
000A 002Eh	USB0	D1FIFO Port Control Register	D1FIFOCTR	16	16	3, 4 PCLKB	2 ICLK	USBb
000A 0030h	USB0	Interrupt Enable Register 0	INTENB0	16	16	9 PCLKB or more	Frequency with $1 + 9 \times (\text{frequency ratio of ICLK/PCLKB})^{*5}$	USBb
000A 0032h	USB0	Interrupt Enable Register 1	INTENB1	16	16	9 PCLKB or more	Frequency with $1 + 9 \times (\text{frequency ratio of ICLK/PCLKB})^{*5}$	USBb
000A 0036h	USB0	BRDY Interrupt Enable Register	BRDYENB	16	16	9 PCLKB or more	Frequency with $1 + 9 \times (\text{frequency ratio of ICLK/PCLKB})^{*5}$	USBb
000A 0038h	USB0	NRDY Interrupt Enable Register	NRDYENB	16	16	9 PCLKB or more	Frequency with $1 + 9 \times (\text{frequency ratio of ICLK/PCLKB})^{*5}$	USBb
000A 003Ah	USB0	BEMP Interrupt Enable Register	BEMPENB	16	16	9 PCLKB or more	Frequency with $1 + 9 \times (\text{frequency ratio of ICLK/PCLKB})^{*5}$	USBb
000A 003Ch	USB0	SOF Output Configuration Register	SOFCFG	16	16	9 PCLKB or more	Frequency with $1 + 9 \times (\text{frequency ratio of ICLK/PCLKB})^{*5}$	USBb
000A 0040h	USB0	Interrupt Status Register 0	INTSTS0	16	16	9 PCLKB or more	Frequency with $1 + 9 \times (\text{frequency ratio of ICLK/PCLKB})^{*5}$	USBb

Table 4.1 List of I/O Registers (Address Order) (43 / 70)

Address	Module Symbol	Register Name	Register Symbol	Number of Bits	Access Size	Number of Access Cycles		Related Function
						ICLK ≥ PCLK	ICLK < PCLK	
000A 0042h	USB0	Interrupt Status Register 1	INTSTS1	16	16	9 PCLKB or more	Frequency with $1 + 9 \times$ (frequency ratio of ICLK/PCLKB) ^{*5}	USBb
000A 0046h	USB0	BRDY Interrupt Status Register	BRDYSTS	16	16	9 PCLKB or more	Frequency with $1 + 9 \times$ (frequency ratio of ICLK/PCLKB) ^{*5}	USBb
000A 0048h	USB0	NRDY Interrupt Status Register	NRDYSTS	16	16	9 PCLKB or more	Frequency with $1 + 9 \times$ (frequency ratio of ICLK/PCLKB) ^{*5}	USBb
000A 004Ah	USB0	BEMP Interrupt Status Register	BEMPSTS	16	16	9 PCLKB or more	Frequency with $1 + 9 \times$ (frequency ratio of ICLK/PCLKB) ^{*5}	USBb
000A 004Ch	USB0	Frame Number Register	FRMNUM	16	16	9 PCLKB or more	Frequency with $1 + 9 \times$ (frequency ratio of ICLK/PCLKB) ^{*5}	USBb
000A 004Eh	USB0	Device State Change Register	DVCHGR	16	16	9 PCLKB or more	Frequency with $1 + 9 \times$ (frequency ratio of ICLK/PCLKB) ^{*5}	USBb
000A 0050h	USB0	USB Address Register	USBADDR	16	16	9 PCLKB or more	Frequency with $1 + 9 \times$ (frequency ratio of ICLK/PCLKB) ^{*5}	USBb
000A 0054h	USB0	USB Request Type Register	USBREQ	16	16	9 PCLKB or more	Frequency with $1 + 9 \times$ (frequency ratio of ICLK/PCLKB) ^{*5}	USBb
000A 0056h	USB0	USB Request Value Register	USBVAL	16	16	9 PCLKB or more	Frequency with $1 + 9 \times$ (frequency ratio of ICLK/PCLKB) ^{*5}	USBb
000A 0058h	USB0	USB Request Index Register	USBINDX	16	16	9 PCLKB or more	Frequency with $1 + 9 \times$ (frequency ratio of ICLK/PCLKB) ^{*5}	USBb
000A 005Ah	USB0	USB Request Length Register	USBLENG	16	16	9 PCLKB or more	Frequency with $1 + 9 \times$ (frequency ratio of ICLK/PCLKB) ^{*5}	USBb
000A 005Ch	USB0	DCP Configuration Register	DCPCFG	16	16	9 PCLKB or more	Frequency with $1 + 9 \times$ (frequency ratio of ICLK/PCLKB) ^{*5}	USBb
000A 005Eh	USB0	DCP Maximum Packet Size Register	DCPMAXP	16	16	9 PCLKB or more	Frequency with $1 + 9 \times$ (frequency ratio of ICLK/PCLKB) ^{*5}	USBb
000A 0060h	USB0	DCP Control Register	DCPCTR	16	16	9 PCLKB or more	Frequency with $1 + 9 \times$ (frequency ratio of ICLK/PCLKB) ^{*5}	USBb
000A 0064h	USB0	Pipe Window Select Register	PIPESEL	16	16	9 PCLKB or more	Frequency with $1 + 9 \times$ (frequency ratio of ICLK/PCLKB) ^{*5}	USBb
000A 0068h	USB0	Pipe Configuration Register	PIPECFG	16	16	9 PCLKB or more	Frequency with $1 + 9 \times$ (frequency ratio of ICLK/PCLKB) ^{*5}	USBb
000A 006Ch	USB0	Pipe Maximum Packet Size Register	PIPEMAXP	16	16	9 PCLKB or more	Frequency with $1 + 9 \times$ (frequency ratio of ICLK/PCLKB) ^{*5}	USBb

Table 4.1 List of I/O Registers (Address Order) (44 / 70)

Address	Module Symbol	Register Name	Register Symbol	Number of Bits	Access Size	Number of Access Cycles		Related Function
						ICLK ≥ PCLK	ICLK < PCLK	
000A 006Eh	USB0	Pipe Cycle Control Register	PIPEPERI	16	16	9 PCLKB or more	Frequency with $1 + 9 \times$ (frequency ratio of ICLK/PCLKB) ^{*5}	USBb
000A 0070h	USB0	PIPE1 Control Register	PIPE1CTR	16	16	9 PCLKB or more	Frequency with $1 + 9 \times$ (frequency ratio of ICLK/PCLKB) ^{*5}	USBb
000A 0072h	USB0	PIPE2 Control Register	PIPE2CTR	16	16	9 PCLKB or more	Frequency with $1 + 9 \times$ (frequency ratio of ICLK/PCLKB) ^{*5}	USBb
000A 0074h	USB0	PIPE3 Control Register	PIPE3CTR	16	16	9 PCLKB or more	Frequency with $1 + 9 \times$ (frequency ratio of ICLK/PCLKB) ^{*5}	USBb
000A 0076h	USB0	PIPE4 Control Register	PIPE4CTR	16	16	9 PCLKB or more	Frequency with $1 + 9 \times$ (frequency ratio of ICLK/PCLKB) ^{*5}	USBb
000A 0078h	USB0	PIPE5 Control Register	PIPE5CTR	16	16	9 PCLKB or more	Frequency with $1 + 9 \times$ (frequency ratio of ICLK/PCLKB) ^{*5}	USBb
000A 007Ah	USB0	PIPE6 Control Register	PIPE6CTR	16	16	9 PCLKB or more	Frequency with $1 + 9 \times$ (frequency ratio of ICLK/PCLKB) ^{*5}	USBb
000A 007Ch	USB0	PIPE7 Control Register	PIPE7CTR	16	16	9 PCLKB or more	Frequency with $1 + 9 \times$ (frequency ratio of ICLK/PCLKB) ^{*5}	USBb
000A 007Eh	USB0	PIPE8 Control Register	PIPE8CTR	16	16	9 PCLKB or more	Frequency with $1 + 9 \times$ (frequency ratio of ICLK/PCLKB) ^{*5}	USBb
000A 0080h	USB0	PIPE9 Control Register	PIPE9CTR	16	16	9 PCLKB or more	Frequency with $1 + 9 \times$ (frequency ratio of ICLK/PCLKB) ^{*5}	USBb
000A 0090h	USB0	Pipe1 Transaction Counter Enable Register	PIPE1TRE	16	16	9 PCLKB or more	Frequency with $1 + 9 \times$ (frequency ratio of ICLK/PCLKB) ^{*5}	USBb
000A 0092h	USB0	Pipe1 Transaction Counter Register	PIPE1TRN	16	16	9 PCLKB or more	Frequency with $1 + 9 \times$ (frequency ratio of ICLK/PCLKB) ^{*5}	USBb
000A 0094h	USB0	Pipe2 Transaction Counter Enable Register	PIPE2TRE	16	16	9 PCLKB or more	Frequency with $1 + 9 \times$ (frequency ratio of ICLK/PCLKB) ^{*5}	USBb
000A 0096h	USB0	Pipe2 Transaction Counter Register	PIPE2TRN	16	16	9 PCLKB or more	Frequency with $1 + 9 \times$ (frequency ratio of ICLK/PCLKB) ^{*5}	USBb
000A 0098h	USB0	Pipe3 Transaction Counter Enable Register	PIPE3TRE	16	16	9 PCLKB or more	Frequency with $1 + 9 \times$ (frequency ratio of ICLK/PCLKB) ^{*5}	USBb
000A 009Ah	USB0	Pipe3 Transaction Counter Register	PIPE3TRN	16	16	9 PCLKB or more	Frequency with $1 + 9 \times$ (frequency ratio of ICLK/PCLKB) ^{*5}	USBb
000A 009Ch	USB0	Pipe4 Transaction Counter Enable Register	PIPE4TRE	16	16	9 PCLKB or more	Frequency with $1 + 9 \times$ (frequency ratio of ICLK/PCLKB) ^{*5}	USBb

Table 4.1 List of I/O Registers (Address Order) (45 / 70)

Address	Module Symbol	Register Name	Register Symbol	Number of Bits	Access Size	Number of Access Cycles		Related Function
						ICLK ≥ PCLK	ICLK < PCLK	
000A 009Eh	USB0	Pipe4 Transaction Counter Register	PIPE4TRN	16	16	9 PCLKB or more	Frequency with $1 + 9 \times$ (frequency ratio of ICLK/PCLKB) ^{*5}	USBb
000A 00A0h	USB0	Pipe5 Transaction Counter Enable Register	PIPE5TRE	16	16	9 PCLKB or more	Frequency with $1 + 9 \times$ (frequency ratio of ICLK/PCLKB) ^{*5}	USBb
000A 00A2h	USB0	Pipe5 Transaction Counter Register	PIPE5TRN	16	16	9 PCLKB or more	Frequency with $1 + 9 \times$ (frequency ratio of ICLK/PCLKB) ^{*5}	USBb
000A 00D0h	USB0	Device Address 0 Configuration Register	DEVADD0	16	16	9 PCLKB or more	Frequency with $1 + 9 \times$ (frequency ratio of ICLK/PCLKB) ^{*5}	USBb
000A 00D2h	USB0	Device Address 1 Configuration Register	DEVADD1	16	16	9 PCLKB or more	Frequency with $1 + 9 \times$ (frequency ratio of ICLK/PCLKB) ^{*5}	USBb
000A 00D4h	USB0	Device Address 2 Configuration Register	DEVADD2	16	16	9 PCLKB or more	Frequency with $1 + 9 \times$ (frequency ratio of ICLK/PCLKB) ^{*5}	USBb
000A 00D6h	USB0	Device Address 3 Configuration Register	DEVADD3	16	16	9 PCLKB or more	Frequency with $1 + 9 \times$ (frequency ratio of ICLK/PCLKB) ^{*5}	USBb
000A 00D8h	USB0	Device Address 4 Configuration Register	DEVADD4	16	16	9 PCLKB or more	Frequency with $1 + 9 \times$ (frequency ratio of ICLK/PCLKB) ^{*5}	USBb
000A 00DAh	USB0	Device Address 5 Configuration Register	DEVADD5	16	16	9 PCLKB or more	Frequency with $1 + 9 \times$ (frequency ratio of ICLK/PCLKB) ^{*5}	USBb
000A 00F0h	USB0	PHY Cross Point Adjustment Register	PHYSLEW	32	32	9 PCLKB or more	Frequency with $1 + 9 \times$ (frequency ratio of ICLK/PCLKB) ^{*5}	USBb
000A 0400h	USB	Deep Standby USB Transceiver Control/Pin Monitoring Register	DPUSR0R	32	32	9 PCLKB or more	Frequency with $1 + 9 \times$ (frequency ratio of ICLK/PCLKB) ^{*5}	USBb
000A 0404h	USB	Deep Standby USB Suspend/Resume Interrupt Register	DPUSR1R	32	32	9 PCLKB or more	Frequency with $1 + 9 \times$ (frequency ratio of ICLK/PCLKB) ^{*5}	USBb
000A 0500h	PDC	PDC Control Register 0	PCCR0	32	32	2, 3 PCLKB	2 ICLK	PDC
000A 0504h	PDC	PDC Control Register 1	PCCR1	32	32	2, 3 PCLKB	2 ICLK	PDC
000A 0508h	PDC	PDC Status Register	PCSR	32	32	2, 3 PCLKB	2 ICLK	PDC
000A 050Ch	PDC	PDC Pin Monitor Register	PCMONR	32	32	2, 3 PCLKB	2 ICLK	PDC
000A 0510h	PDC	PDC Receive Data Register	PCDR	32	32	2, 3 PCLKB	2 ICLK	PDC
000A 0514h	PDC	Vertical Capture Register	VCR	32	32	2, 3 PCLKB	2 ICLK	PDC
000A 0518h	PDC	Horizontal Capture Register	HCR	32	32	2, 3 PCLKB	2 ICLK	PDC
000C 0000h	EDMAC0	EDMAC Mode Register	EDMR	32	32	4, 5 PCLKA	2, 3 ICLK	EDMACa
000C 0008h	EDMAC0	EDMAC Transmit Request Register	EDTRR	32	32	4, 5 PCLKA	2, 3 ICLK	EDMACa
000C 0010h	EDMAC0	EDMAC Receive Request Register	EDRRR	32	32	4, 5 PCLKA	2, 3 ICLK	EDMACa
000C 0018h	EDMAC0	Transmit Descriptor List Start Address Register	TDLAR	32	32	4, 5 PCLKA	2, 3 ICLK	EDMACa
000C 0020h	EDMAC0	Receive Descriptor List Start Address Register	RDLAR	32	32	4, 5 PCLKA	2, 3 ICLK	EDMACa
000C 0028h	EDMAC0	ETHERC/EDMAC Status Register	EESR	32	32	4, 5 PCLKA	2, 3 ICLK	EDMACa

Table 4.1 List of I/O Registers (Address Order) (46 / 70)

Address	Module Symbol	Register Name	Register Symbol	Number of Bits	Access Size	Number of Access Cycles		Related Function
						ICLK ≥ PCLKA	ICLK < PCLKA	
000C 0030h	EDMAC0	ETHERC/EDMAC Status Interrupt Enable Register	EESIPR	32	32	4, 5 PCLKA	2, 3 ICLK	EDMACa
000C 0038h	EDMAC0	ETHERC/EDMAC Transmit/Receive Status Copy Enable Register	TRSCER	32	32	4, 5 PCLKA	2, 3 ICLK	EDMACa
000C 0040h	EDMAC0	Missed-Frame Counter Register	RMFCR	32	32	4, 5 PCLKA	2, 3 ICLK	EDMACa
000C 0048h	EDMAC0	Transmit FIFO Threshold Register	TFTR	32	32	4, 5 PCLKA	2, 3 ICLK	EDMACa
000C 0050h	EDMAC0	FIFO Depth Register	FDR	32	32	4, 5 PCLKA	2, 3 ICLK	EDMACa
000C 0058h	EDMAC0	Receive Method Control Register	RMCR	32	32	4, 5 PCLKA	2, 3 ICLK	EDMACa
000C 0064h	EDMAC0	Transmit FIFO Underflow Counter	TFUCR	32	32	4, 5 PCLKA	2, 3 ICLK	EDMACa
000C 0068h	EDMAC0	Receive FIFO Overflow Counter	RFOCR	32	32	4, 5 PCLKA	2, 3 ICLK	EDMACa
000C 006Ch	EDMAC0	Independent Output Signal Setting Register	IOSR	32	32	4, 5 PCLKA	2, 3 ICLK	EDMACa
000C 0070h	EDMAC0	Flow Control Start FIFO Threshold Setting Register	FCFTR	32	32	4, 5 PCLKA	2, 3 ICLK	EDMACa
000C 0078h	EDMAC0	Receive Data Padding Insert Register	RPADIR	32	32	4, 5 PCLKA	2, 3 ICLK	EDMACa
000C 007Ch	EDMAC0	Transmit Interrupt Setting Register	TRIMD	32	32	4, 5 PCLKA	2, 3 ICLK	EDMACa
000C 00C8h	EDMAC0	Receive Buffer Write Address Register	RBWAR	32	32	4, 5 PCLKA	2, 3 ICLK	EDMACa
000C 00CCh	EDMAC0	Receive Descriptor Fetch Address Register	RDFAR	32	32	4, 5 PCLKA	2, 3 ICLK	EDMACa
000C 00D4h	EDMAC0	Transmit Buffer Read Address Register	TBRAR	32	32	4, 5 PCLKA	2, 3 ICLK	EDMACa
000C 00D8h	EDMAC0	Transmit Descriptor Fetch Address Register	TDFAR	32	32	4, 5 PCLKA	2, 3 ICLK	EDMACa
000C 0100h	ETHERC0	ETHERC Mode Register	ECMR	32	32	13, 14 PCLKA	2 to 7 ICLK	ETHERC
000C 0108h	ETHERC0	Receive Frame Maximum Length Register	RFLR	32	32	13, 14 PCLKA	2 to 7 ICLK	ETHERC
000C 0110h	ETHERC0	ETHERC Status Register	ECSR	32	32	13, 14 PCLKA	2 to 7 ICLK	ETHERC
000C 0118h	ETHERC0	ETHERC Interrupt Enable Register	ECSIPR	32	32	13, 14 PCLKA	2 to 7 ICLK	ETHERC
000C 0120h	ETHERC0	PHY Interface Register	PIR	32	32	13, 14 PCLKA	2 to 7 ICLK	ETHERC
000C 0128h	ETHERC0	PHY Status Register	PSR	32	32	13, 14 PCLKA	2 to 7 ICLK	ETHERC
000C 0140h	ETHERC0	Random Number Generation Counter Limit Setting Register	RDMLR	32	32	13, 14 PCLKA	2 to 7 ICLK	ETHERC
000C 0150h	ETHERC0	Interpacket Gap Register	IPGR	32	32	13, 14 PCLKA	2 to 7 ICLK	ETHERC
000C 0154h	ETHERC0	Automatic PAUSE Frame Register	APR	32	32	13, 14 PCLKA	2 to 7 ICLK	ETHERC
000C 0158h	ETHERC0	Manual PAUSE Frame Register	MPR	32	32	13, 14 PCLKA	2 to 7 ICLK	ETHERC
000C 0160h	ETHERC0	Received PAUSE Frame Counter	RFCF	32	32	13, 14 PCLKA	2 to 7 ICLK	ETHERC
000C 0164h	ETHERC0	PAUSE Frame Retransmit Count Setting Register	TPAUSER	32	32	13, 14 PCLKA	2 to 7 ICLK	ETHERC
000C 0168h	ETHERC0	PAUSE Frame Retransmit Counter	TPAUSECR	32	32	13, 14 PCLKA	2 to 7 ICLK	ETHERC
000C 016Ch	ETHERC0	Broadcast Frame Receive Count Setting Register	BCFRR	32	32	13, 14 PCLKA	2 to 7 ICLK	ETHERC
000C 01C0h	ETHERC0	MAC Address Upper Bit Register	MAHR	32	32	13, 14 PCLKA	2 to 7 ICLK	ETHERC

Table 4.1 List of I/O Registers (Address Order) (47 / 70)

Address	Module Symbol	Register Name	Register Symbol	Number of Bits	Access Size	Number of Access Cycles		Related Function
						ICLK ≥ PCLK	ICLK < PCLK	
000C 01C8h	ETHER C0	MAC Address Lower Bit Register	MALR	32	32	13, 14 PCLKA	2 to 7 ICLK	ETHER C
000C 01D0h	ETHER C0	Transmit Retry Over Counter Register	TROCR	32	32	13, 14 PCLKA	2 to 7 ICLK	ETHER C
000C 01D4h	ETHER C0	Late Collision Detect Counter Register	CDCR	32	32	13, 14 PCLKA	2 to 7 ICLK	ETHER C
000C 01D8h	ETHER C0	Lost Carrier Counter Register	LCCR	32	32	13, 14 PCLKA	2 to 7 ICLK	ETHER C
000C 01DCh	ETHER C0	Carrier Not Detect Counter Register	CNDCR	32	32	13, 14 PCLKA	2 to 7 ICLK	ETHER C
000C 01E4h	ETHER C0	CRC Error Frame Receive Counter Register	GEFCR	32	32	13, 14 PCLKA	2 to 7 ICLK	ETHER C
000C 01E8h	ETHER C0	Frame Receive Error Counter Register	FRECR	32	32	13, 14 PCLKA	2 to 7 ICLK	ETHER C
000C 01ECh	ETHER C0	Too-Short Frame Receive Counter Register	TSFRCR	32	32	13, 14 PCLKA	2 to 7 ICLK	ETHER C
000C 01F0h	ETHER C0	Too-Long Frame Receive Counter Register	TLFRCR	32	32	13, 14 PCLKA	2 to 7 ICLK	ETHER C
000C 01F4h	ETHER C0	Received Alignment Error Frame Counter Register	RFCR	32	32	13, 14 PCLKA	2 to 7 ICLK	ETHER C
000C 01F8h	ETHER C0	Multicast Address Frame Receive Counter Register	MAFCR	32	32	13, 14 PCLKA	2 to 7 ICLK	ETHER C
000C 0200h	EDMAC 1	EDMAC Mode Register	EDMR	32	32	4, 5 PCLKA	2, 3 ICLK	EDMAC a
000C 0208h	EDMAC 1	EDMAC Transmit Request Register	EDTRR	32	32	4, 5 PCLKA	2, 3 ICLK	EDMAC a
000C 0210h	EDMAC 1	EDMAC Receive Request Register	EDRRR	32	32	4, 5 PCLKA	2, 3 ICLK	EDMAC a
000C 0218h	EDMAC 1	Transmit Descriptor List Start Address Register	TDLAR	32	32	4, 5 PCLKA	2, 3 ICLK	EDMAC a
000C 0220h	EDMAC 1	Receive Descriptor List Start Address Register	RDLAR	32	32	4, 5 PCLKA	2, 3 ICLK	EDMAC a
000C 0228h	EDMAC 1	ETHERC/EDMAC Status Register	EESR	32	32	4, 5 PCLKA	2, 3 ICLK	EDMAC a
000C 0230h	EDMAC 1	ETHERC/EDMAC Status Interrupt Enable Register	EESIPR	32	32	4, 5 PCLKA	2, 3 ICLK	EDMAC a
000C 0238h	EDMAC 1	ETHERC/EDMAC Transmit/Receive Status Copy Enable Register	TRSCER	32	32	4, 5 PCLKA	2, 3 ICLK	EDMAC a
000C 0240h	EDMAC 1	Missed-Frame Counter Register	RMFCR	32	32	4, 5 PCLKA	2, 3 ICLK	EDMAC a
000C 0248h	EDMAC 1	Transmit FIFO Threshold Register	TFTR	32	32	4, 5 PCLKA	2, 3 ICLK	EDMAC a
000C 0250h	EDMAC 1	FIFO Depth Register	FDR	32	32	4, 5 PCLKA	2, 3 ICLK	EDMAC a
000C 0258h	EDMAC 1	Receive Method Control Register	RMCR	32	32	4, 5 PCLKA	2, 3 ICLK	EDMAC a
000C 0264h	EDMAC 1	Transmit FIFO Underflow Counter	TFUCR	32	32	4, 5 PCLKA	2, 3 ICLK	EDMAC a
000C 0268h	EDMAC 1	Receive FIFO Overflow Counter	RFOCR	32	32	4, 5 PCLKA	2, 3 ICLK	EDMAC a
000C 026Ch	EDMAC 1	Independent Output Signal Setting Register	IOSR	32	32	4, 5 PCLKA	2, 3 ICLK	EDMAC a
000C 0270h	EDMAC 1	Flow Control Start FIFO Threshold Setting Register	FCFTR	32	32	4, 5 PCLKA	2, 3 ICLK	EDMAC a
000C 0278h	EDMAC 1	Receive Data Padding Insert Register	RPADIR	32	32	4, 5 PCLKA	2, 3 ICLK	EDMAC a
000C 027Ch	EDMAC 1	Transmit Interrupt Setting Register	TRIMD	32	32	4, 5 PCLKA	2, 3 ICLK	EDMAC a
000C 02C8h	EDMAC 1	Receive Buffer Write Address Register	RBWAR	32	32	4, 5 PCLKA	2, 3 ICLK	EDMAC a
000C 02CCh	EDMAC 1	Receive Descriptor Fetch Address Register	RDFAR	32	32	4, 5 PCLKA	2, 3 ICLK	EDMAC a

Table 4.1 List of I/O Registers (Address Order) (48 / 70)

Address	Module Symbol	Register Name	Register Symbol	Number of Bits	Access Size	Number of Access Cycles		Related Function
						ICLK ≥ PCLK	ICLK < PCLK	
000C 02D4h	EDMAC 1	Transmit Buffer Read Address Register	TBRAR	32	32	4, 5 PCLKA	2, 3 ICLK	EDMAC a
000C 02D8h	EDMAC 1	Transmit Descriptor Fetch Address Register	TDFAR	32	32	4, 5 PCLKA	2, 3 ICLK	EDMAC a
000C 0300h	ETHER C1	ETHERC Mode Register	ECMR	32	32	13, 14 PCLKA	2 to 7 ICLK	ETHER C
000C 0308h	ETHER C1	Receive Frame Length Register	RFLR	32	32	13, 14 PCLKA	2 to 7 ICLK	ETHER C
000C 0310h	ETHER C1	ETHERC Status Register	ECSR	32	32	13, 14 PCLKA	2 to 7 ICLK	ETHER C
000C 0318h	ETHER C1	ETHERC Interrupt Enable Register	ECSIPR	32	32	13, 14 PCLKA	2 to 7 ICLK	ETHER C
000C 0320h	ETHER C1	PHY Interface Register	PIR	32	32	13, 14 PCLKA	2 to 7 ICLK	ETHER C
000C 0328h	ETHER C1	PHY Status Register	PSR	32	32	13, 14 PCLKA	2 to 7 ICLK	ETHER C
000C 0340h	ETHER C1	Random Number Generation Counter Upper Limit Setting Register	RDMLR	32	32	13, 14 PCLKA	2 to 7 ICLK	ETHER C
000C 0350h	ETHER C1	Interpacket Gap Register	IPGR	32	32	13, 14 PCLKA	2 to 7 ICLK	ETHER C
000C 0354h	ETHER C1	Automatic PAUSE Frame Register	APR	32	32	13, 14 PCLKA	2 to 7 ICLK	ETHER C
000C 0358h	ETHER C1	Manual PAUSE Frame Register	MPR	32	32	13, 14 PCLKA	2 to 7 ICLK	ETHER C
000C 0360h	ETHER C1	Received PAUSE Frame Counter	RFCF	32	32	13, 14 PCLKA	2 to 7 ICLK	ETHER C
000C 0364h	ETHER C1	PAUSE Frame Retransmit Count Setting Register	TPAUSER	32	32	13, 14 PCLKA	2 to 7 ICLK	ETHER C
000C 0368h	ETHER C1	PAUSE Frame Retransmit Counter Register	TPAUSECR	32	32	13, 14 PCLKA	2 to 7 ICLK	ETHER C
000C 036Ch	ETHER C1	Broadcast Frame Receive Count Setting Register	BCFRR	32	32	13, 14 PCLKA	2 to 7 ICLK	ETHER C
000C 03C0h	ETHER C1	MAC Address Upper Bit Register	MAHR	32	32	13, 14 PCLKA	2 to 7 ICLK	ETHER C
000C 03C8h	ETHER C1	MAC Address Lower Bit Register	MALR	32	32	13, 14 PCLKA	2 to 7 ICLK	ETHER C
000C 03D0h	ETHER C1	Transmit Retry Over Counter Register	TROCR	32	32	13, 14 PCLKA	2 to 7 ICLK	ETHER C
000C 03D4h	ETHER C1	Late Collision Detect Counter Register	GDCR	32	32	13, 14 PCLKA	2 to 7 ICLK	ETHER C
000C 03D8h	ETHER C1	Lost Carrier Counter Register	LCCR	32	32	13, 14 PCLKA	2 to 7 ICLK	ETHER C
000C 03DCh	ETHER C1	Carrier Not Detect Counter Register	CNDCR	32	32	13, 14 PCLKA	2 to 7 ICLK	ETHER C
000C 03E4h	ETHER C1	CRC Error Frame Receive Counter Register	CEFCR	32	32	13, 14 PCLKA	2 to 7 ICLK	ETHER C
000C 03E8h	ETHER C1	Frame Receive Error Counter Register	FRECR	32	32	13, 14 PCLKA	2 to 7 ICLK	ETHER C
000C 03ECh	ETHER C1	Too-Short Frame Receive Counter Register	TSFRRCR	32	32	13, 14 PCLKA	2 to 7 ICLK	ETHER C
000C 03F0h	ETHER C1	Too-Long Frame Receive Counter Register	TLFRRCR	32	32	13, 14 PCLKA	2 to 7 ICLK	ETHER C
000C 03F4h	ETHER C1	Received Alignment Error Frame Counter Register	RFCR	32	32	13, 14 PCLKA	2 to 7 ICLK	ETHER C
000C 03F8h	ETHER C1	Multicast Address Frame Receive Counter Register	MAFCR	32	32	13, 14 PCLKA	2 to 7 ICLK	ETHER C
000C 0400h	PTPED MAC	EDMAC Mode Register	EDMR	32	32	4, 5 PCLKA	2, 3 ICLK	EDMAC a
000C 0408h	PTPED MAC	EDMAC Transmit Request Register	EDTRR	32	32	4, 5 PCLKA	2, 3 ICLK	EDMAC a
000C 0410h	PTPED MAC	EDMAC Receive Request Register	EDRRR	32	32	4, 5 PCLKA	2, 3 ICLK	EDMAC a

Table 4.1 List of I/O Registers (Address Order) (49 / 70)

Address	Module Symbol	Register Name	Register Symbol	Number of Bits	Access Size	Number of Access Cycles		Related Function
						ICLK ≥ PCLK	ICLK < PCLK	
000C 0418h	PTPED MAC	Transmit Descriptor List Start Address Register	TDLAR	32	32	4, 5 PCLKA	2, 3 ICLK	EDMAC a
000C 0420h	PTPED MAC	Receive Descriptor List Start Address Register	RDLAR	32	32	4, 5 PCLKA	2, 3 ICLK	EDMAC a
000C 0428h	PTPED MAC	PTP/EDMAC Status Register	EESR	32	32	4, 5 PCLKA	2, 3 ICLK	EDMAC a
000C 0430h	PTPED MAC	PTP/EDMAC Status Interrupt Enable Register	EESIPR	32	32	4, 5 PCLKA	2, 3 ICLK	EDMAC a
000C 0440h	PTPED MAC	Missed-Frame Counter Register	RMFCR	32	32	4, 5 PCLKA	2, 3 ICLK	EDMAC a
000C 0448h	PTPED MAC	Transmit FIFO Threshold Register	TFTR	32	32	4, 5 PCLKA	2, 3 ICLK	EDMAC a
000C 0450h	PTPED MAC	FIFO Depth Register	FDR	32	32	4, 5 PCLKA	2, 3 ICLK	EDMAC a
000C 0458h	PTPED MAC	Receive Method Control Register	RMCR	32	32	4, 5 PCLKA	2, 3 ICLK	EDMAC a
000C 0464h	PTPED MAC	Transmit FIFO Underflow Counter	TFUCR	32	32	4, 5 PCLKA	2, 3 ICLK	EDMAC a
000C 0468h	PTPED MAC	Receive FIFO Overflow Counter	RFOCR	32	32	4, 5 PCLKA	2, 3 ICLK	EDMAC a
000C 0470h	PTPED MAC	Flow Control Start FIFO Threshold Setting Register	FCFTR	32	32	4, 5 PCLKA	2, 3 ICLK	EDMAC a
000C 0478h	PTPED MAC	Receive Data Padding Insert Register	RPADIR	32	32	4, 5 PCLKA	2, 3 ICLK	EDMAC a
000C 047Ch	PTPED MAC	Transmit Interrupt Setting Register	TRIMD	32	32	4, 5 PCLKA	2, 3 ICLK	EDMAC a
000C 04C8h	PTPED MAC	Receive Buffer Write Address Register	RBWAR	32	32	4, 5 PCLKA	2, 3 ICLK	EDMAC a
000C 04CCh	PTPED MAC	Receive Descriptor Fetch Address Register	RDFAR	32	32	4, 5 PCLKA	2, 3 ICLK	EDMAC a
000C 04D4h	PTPED MAC	Transmit Buffer Read Address Register	TBRAR	32	32	4, 5 PCLKA	2, 3 ICLK	EDMAC a
000C 04D8h	PTPED MAC	Transmit Descriptor Fetch Address Register	TDFAR	32	32	4, 5 PCLKA	2, 3 ICLK	EDMAC a
000C 0500h	EPTPC	PTP Reset Register	PTRSTR	32	32	3, 4 PCLKA	2, 3 ICLK	EPTPC a
000C 0504h	EPTPC	STCA Clock Select Register	STCSELR	32	32	3, 4 PCLKA	2, 3 ICLK	EPTPC a
000C 1200h	MTU3	Timer Control Register	TCR	8	8	5, 6 PCLKA	2, 3 ICLK	MTU3a
000C 1201h	MTU4	Timer Control Register	TCR	8	8	5, 6 PCLKA	2, 3 ICLK	MTU3a
000C 1202h	MTU3	Timer Mode Register 1	TMDR1	8	8	5, 6 PCLKA	2, 3 ICLK	MTU3a
000C 1203h	MTU4	Timer Mode Register 1	TMDR1	8	8	5, 6 PCLKA	2, 3 ICLK	MTU3a
000C 1204h	MTU3	Timer I/O Control Register H	TIORH	8	8	5, 6 PCLKA	2, 3 ICLK	MTU3a
000C 1205h	MTU3	Timer I/O Control Register L	TIORL	8	8	5, 6 PCLKA	2, 3 ICLK	MTU3a
000C 1206h	MTU4	Timer I/O Control Register H	TIORH	8	8	5, 6 PCLKA	2, 3 ICLK	MTU3a
000C 1207h	MTU4	Timer I/O Control Register L	TIORL	8	8	5, 6 PCLKA	2, 3 ICLK	MTU3a
000C 1208h	MTU3	Timer Interrupt Enable Register	TIER	8	8	5, 6 PCLKA	2, 3 ICLK	MTU3a
000C 1209h	MTU4	Timer Interrupt Enable Register	TIER	8	8	5, 6 PCLKA	2, 3 ICLK	MTU3a
000C 120Ah	MTU	Timer Output Master Enable Register A	TOERA	8	8	5, 6 PCLKA	2, 3 ICLK	MTU3a
000C 120Dh	MTU	Timer Gate Control Register A	TGCRA	8	8	5, 6 PCLKA	2, 3 ICLK	MTU3a
000C 120Eh	MTU	Timer Output Control Register 1A	TOCR1A	8	8	5, 6 PCLKA	2, 3 ICLK	MTU3a
000C 120Fh	MTU	Timer Output Control Register 2A	TOCR2A	8	8	5, 6 PCLKA	2, 3 ICLK	MTU3a
000C 1210h	MTU3	Timer Counter	TCNT	16	16	5, 6 PCLKA	2, 3 ICLK	MTU3a
000C 1212h	MTU4	Timer Counter	TCNT	16	16	5, 6 PCLKA	2, 3 ICLK	MTU3a
000C 1214h	MTU	Timer Cycle Data Register A	TCDRA	16	16	5, 6 PCLKA	2, 3 ICLK	MTU3a
000C 1216h	MTU	Timer Dead Time Data Register A	TDDRA	16	16	5, 6 PCLKA	2, 3 ICLK	MTU3a
000C 1218h	MTU3	Timer General Register A	TGRA	16	16	5, 6 PCLKA	2, 3 ICLK	MTU3a
000C 121Ah	MTU3	Timer General Register B	TGRB	16	16	5, 6 PCLKA	2, 3 ICLK	MTU3a

Table 4.1 List of I/O Registers (Address Order) (50 / 70)

Address	Module Symbol	Register Name	Register Symbol	Number of Bits	Access Size	Number of Access Cycles		Related Function
						ICLK ≥ PCLK	ICLK < PCLK	
000C 121Ch	MTU4	Timer General Register A	TGRA	16	16	5, 6 PCLKA	2, 3 ICLK	MTU3a
000C 121Eh	MTU4	Timer General Register B	TGRB	16	16	5, 6 PCLKA	2, 3 ICLK	MTU3a
000C 1220h	MTU	Timer Subcounter A	TCNTSA	16	16	5, 6 PCLKA	2, 3 ICLK	MTU3a
000C 1222h	MTU	Timer Cycle Buffer Register A	TCBRA	16	16	5, 6 PCLKA	2, 3 ICLK	MTU3a
000C 1224h	MTU3	Timer General Register C	TGRC	16	16	5, 6 PCLKA	2, 3 ICLK	MTU3a
000C 1226h	MTU3	Timer General Register D	TGRD	16	16	5, 6 PCLKA	2, 3 ICLK	MTU3a
000C 1228h	MTU4	Timer General Register C	TGRC	16	16	5, 6 PCLKA	2, 3 ICLK	MTU3a
000C 122Ah	MTU4	Timer General Register D	TGRD	16	16	5, 6 PCLKA	2, 3 ICLK	MTU3a
000C 122Ch	MTU3	Timer Status Register	TSR	8	8	5, 6 PCLKA	2, 3 ICLK	MTU3a
000C 122Dh	MTU4	Timer Status Register	TSR	8	8	5, 6 PCLKA	2, 3 ICLK	MTU3a
000C 1230h	MTU	Timer Interrupt Skipping Set Register 1A	TITCR1A	8	8	5, 6 PCLKA	2, 3 ICLK	MTU3a
000C 1231h	MTU	Timer Interrupt Skipping Counter 1A	TITCNT1A	8	8	5, 6 PCLKA	2, 3 ICLK	MTU3a
000C 1232h	MTU	Timer Buffer Transfer Set Register A	TBTERA	8	8	5, 6 PCLKA	2, 3 ICLK	MTU3a
000C 1234h	MTU	Timer Dead Time Enable Register A	TDERA	8	8	5, 6 PCLKA	2, 3 ICLK	MTU3a
000C 1236h	MTU	Timer Output Level Buffer Register A	TOLBRA	8	8	5, 6 PCLKA	2, 3 ICLK	MTU3a
000C 1238h	MTU3	Timer Buffer Operation Transfer Mode Register	TBTM	8	8	5, 6 PCLKA	2, 3 ICLK	MTU3a
000C 1239h	MTU4	Timer Buffer Operation Transfer Mode Register	TBTM	8	8	5, 6 PCLKA	2, 3 ICLK	MTU3a
000C 123Ah	MTU	Timer Interrupt Skipping Mode Register A	TITMRA	8	8	5, 6 PCLKA	2, 3 ICLK	MTU3a
000C 123Bh	MTU	Timer Interrupt Skipping Set Register 2A	TITCR2A	8	8	5, 6 PCLKA	2, 3 ICLK	MTU3a
000C 123Ch	MTU	Timer Interrupt Skipping Counter 2A	TITCNT2A	8	8	5, 6 PCLKA	2, 3 ICLK	MTU3a
000C 1240h	MTU4	Timer A/D Converter Start Request Control Register	TADCR	16	16	5, 6 PCLKA	2, 3 ICLK	MTU3a
000C 1244h	MTU4	Timer A/D Converter Start Request Cycle Set Register A	TADCORA	16	16	5, 6 PCLKA	2, 3 ICLK	MTU3a
000C 1246h	MTU4	Timer A/D Converter Start Request Cycle Set Register B	TADCORB	16	16	5, 6 PCLKA	2, 3 ICLK	MTU3a
000C 1248h	MTU4	Timer A/D Converter Start Request Cycle Set Buffer Register A	TADCOBRA	16	16	5, 6 PCLKA	2, 3 ICLK	MTU3a
000C 124Ah	MTU4	Timer A/D Converter Start Request Cycle Set Buffer Register B	TADCOBRB	16	16	5, 6 PCLKA	2, 3 ICLK	MTU3a
000C 124Ch	MTU3	Timer Control Register 2	TCR2	8	8	5, 6 PCLKA	2, 3 ICLK	MTU3a
000C 124Dh	MTU4	Timer Control Register 2	TCR2	8	8	5, 6 PCLKA	2, 3 ICLK	MTU3a
000C 1260h	MTU	Timer Waveform Control Register A	TWCRA	8	8	5, 6 PCLKA	2, 3 ICLK	MTU3a
000C 1270h	MTU	Timer Mode Register 2A	TMDR2A	8	8	5, 6 PCLKA	2, 3 ICLK	MTU3a
000C 1272h	MTU3	Timer General Register E	TGRE	16	16	5, 6 PCLKA	2, 3 ICLK	MTU3a
000C 1274h	MTU4	Timer General Register E	TGRE	16	16	5, 6 PCLKA	2, 3 ICLK	MTU3a
000C 1276h	MTU4	Timer General Register F	TGRF	16	16	5, 6 PCLKA	2, 3 ICLK	MTU3a
000C 1280h	MTU	Timer Start Register A	TSTRA	8	8	5, 6 PCLKA	2, 3 ICLK	MTU3a
000C 1281h	MTU	Timer Synchronous Register A	TSYRA	8	8	5, 6 PCLKA	2, 3 ICLK	MTU3a
000C 1282h	MTU	Timer Counter Synchronous Start Register	TCSYSTR	8	8	5, 6 PCLKA	2, 3 ICLK	MTU3a
000C 1284h	MTU	Timer Read/Write Enable Register A	TRWERA	8	8	5, 6 PCLKA	2, 3 ICLK	MTU3a
000C 1290h	MTU0	Noise Filter Control Register 0	NFCR0	8	8	5, 6 PCLKA	2, 3 ICLK	MTU3a
000C 1291h	MTU1	Noise Filter Control Register 1	NFCR1	8	8	5, 6 PCLKA	2, 3 ICLK	MTU3a
000C 1292h	MTU2	Noise Filter Control Register 2	NFCR2	8	8	5, 6 PCLKA	2, 3 ICLK	MTU3a
000C 1293h	MTU3	Noise Filter Control Register 3	NFCR3	8	8	5, 6 PCLKA	2, 3 ICLK	MTU3a
000C 1294h	MTU4	Noise Filter Control Register 4	NFCR4	8	8	5, 6 PCLKA	2, 3 ICLK	MTU3a
000C 1298h	MTU8	Noise Filter Control Register 8	NFCR8	8	8	5, 6 PCLKA	2, 3 ICLK	MTU3a
000C 1299h	MTU0	Noise Filter Control Register C	NFCRC	8	8	5, 6 PCLKA	2, 3 ICLK	MTU3a
000C 1300h	MTU0	Timer Control Register	TCR	8	8	5, 6 PCLKA	2, 3 ICLK	MTU3a
000C 1301h	MTU0	Timer Mode Register 1	TMDR1	8	8	5, 6 PCLKA	2, 3 ICLK	MTU3a
000C 1302h	MTU0	Timer I/O Control Register H	TIORH	8	8	5, 6 PCLKA	2, 3 ICLK	MTU3a
000C 1303h	MTU0	Timer I/O Control Register L	TIORL	8	8	5, 6 PCLKA	2, 3 ICLK	MTU3a

Table 4.1 List of I/O Registers (Address Order) (51 / 70)

Address	Module Symbol	Register Name	Register Symbol	Number of Bits	Access Size	Number of Access Cycles		Related Function
						ICLK ≥ PCLK	ICLK < PCLK	
000C 1304h	MTU0	Timer Interrupt Enable Register	TIER	8	8	5, 6 PCLKA	2, 3 ICLK	MTU3a
000C 1306h	MTU0	Timer Counter	TCNT	16	16	5, 6 PCLKA	2, 3 ICLK	MTU3a
000C 1308h	MTU0	Timer General Register A	TGRA	16	16	5, 6 PCLKA	2, 3 ICLK	MTU3a
000C 130Ah	MTU0	Timer General Register B	TGRB	16	16	5, 6 PCLKA	2, 3 ICLK	MTU3a
000C 130Ch	MTU0	Timer General Register C	TGRC	16	16	5, 6 PCLKA	2, 3 ICLK	MTU3a
000C 130Eh	MTU0	Timer General Register D	TGRD	16	16	5, 6 PCLKA	2, 3 ICLK	MTU3a
000C 1320h	MTU0	Timer General Register E	TGRE	16	16	5, 6 PCLKA	2, 3 ICLK	MTU3a
000C 1322h	MTU0	Timer General Register F	TGRF	16	16	5, 6 PCLKA	2, 3 ICLK	MTU3a
000C 1324h	MTU0	Timer Interrupt Enable Register 2	TIER2	8	8	5, 6 PCLKA	2, 3 ICLK	MTU3a
000C 1326h	MTU0	Timer Buffer Operation Transfer Mode Register	TBTM	8	8	5, 6 PCLKA	2, 3 ICLK	MTU3a
000C 1328h	MTU0	Timer Control Register 2	TCR2	8	8	5, 6 PCLKA	2, 3 ICLK	MTU3a
000C 1380h	MTU1	Timer Control Register	TCR	8	8	5, 6 PCLKA	2, 3 ICLK	MTU3a
000C 1381h	MTU1	Timer Mode Register 1	TMDR1	8	8	5, 6 PCLKA	2, 3 ICLK	MTU3a
000C 1382h	MTU1	Timer I/O Control Register	TIOR	8	8	5, 6 PCLKA	2, 3 ICLK	MTU3a
000C 1384h	MTU1	Timer Interrupt Enable Register	TIER	8	8	5, 6 PCLKA	2, 3 ICLK	MTU3a
000C 1385h	MTU1	Timer Status Register	TSR	8	8	5, 6 PCLKA	2, 3 ICLK	MTU3a
000C 1386h	MTU1	Timer Counter	TCNT	16	16	5, 6 PCLKA	2, 3 ICLK	MTU3a
000C 1388h	MTU1	Timer General Register A	TGRA	16	16	5, 6 PCLKA	2, 3 ICLK	MTU3a
000C 138Ah	MTU1	Timer General Register B	TGRB	16	16	5, 6 PCLKA	2, 3 ICLK	MTU3a
000C 1390h	MTU1	Timer Input Capture Control Register	TICCR	8	8	5, 6 PCLKA	2, 3 ICLK	MTU3a
000C 1391h	MTU1	Timer Mode Register 3	TMDR3	8	8	5, 6 PCLKA	2, 3 ICLK	MTU3a
000C 1394h	MTU1	Timer Control Register 2	TCR2	8	8	5, 6 PCLKA	2, 3 ICLK	MTU3a
000C 13A0h	MTU1	Timer Longword Counter	TCNTLW	32	32	5, 6 PCLKA	2, 3 ICLK	MTU3a
000C 13A4h	MTU1	Timer Longword General Register	TGRALW	32	32	5, 6 PCLKA	2, 3 ICLK	MTU3a
000C 13A8h	MTU1	Timer Longword General Register	TGRBLW	32	32	5, 6 PCLKA	2, 3 ICLK	MTU3a
000C 1400h	MTU2	Timer Control Register	TCR	8	8	5, 6 PCLKA	2, 3 ICLK	MTU3a
000C 1401h	MTU2	Timer Mode Register 1	TMDR1	8	8	5, 6 PCLKA	2, 3 ICLK	MTU3a
000C 1402h	MTU2	Timer I/O Control Register	TIOR	8	8	5, 6 PCLKA	2, 3 ICLK	MTU3a
000C 1404h	MTU2	Timer Interrupt Enable Register	TIER	8	8	5, 6 PCLKA	2, 3 ICLK	MTU3a
000C 1405h	MTU2	Timer Status Register	TSR	8	8	5, 6 PCLKA	2, 3 ICLK	MTU3a
000C 1406h	MTU2	Timer Counter	TCNT	16	16	5, 6 PCLKA	2, 3 ICLK	MTU3a
000C 1408h	MTU2	Timer General Register A	TGRA	16	16	5, 6 PCLKA	2, 3 ICLK	MTU3a
000C 140Ah	MTU2	Timer General Register B	TGRB	16	16	5, 6 PCLKA	2, 3 ICLK	MTU3a
000C 140Ch	MTU2	Timer Control Register 2	TCR2	8	8	5, 6 PCLKA	2, 3 ICLK	MTU3a
000C 1600h	MTU8	Timer Control Register	TCR	8	8	5, 6 PCLKA	2, 3 ICLK	MTU3a
000C 1601h	MTU8	Timer Mode Register 1	TMDR1	8	8	5, 6 PCLKA	2, 3 ICLK	MTU3a
000C 1602h	MTU8	Timer I/O Control Register H	TIORH	8	8	5, 6 PCLKA	2, 3 ICLK	MTU3a
000C 1603h	MTU8	Timer I/O Control Register L	TIORL	8	8	5, 6 PCLKA	2, 3 ICLK	MTU3a
000C 1604h	MTU8	Timer Interrupt Enable Register	TIER	8	8	5, 6 PCLKA	2, 3 ICLK	MTU3a
000C 1606h	MTU8	Timer Control Register 2	TCR2	8	8	5, 6 PCLKA	2, 3 ICLK	MTU3a
000C 1608h	MTU8	Timer Counter	TCNT	32	32	5, 6 PCLKA	2, 3 ICLK	MTU3a
000C 160Ch	MTU8	Timer General Register A	TGRA	32	32	5, 6 PCLKA	2, 3 ICLK	MTU3a
000C 1610h	MTU8	Timer General Register B	TGRB	32	32	5, 6 PCLKA	2, 3 ICLK	MTU3a
000C 1614h	MTU8	Timer General Register C	TGRC	32	32	5, 6 PCLKA	2, 3 ICLK	MTU3a
000C 1618h	MTU8	Timer General Register D	TGRD	32	32	5, 6 PCLKA	2, 3 ICLK	MTU3a
000C 1A00h	MTU6	Timer Control Register	TCR	8	8	5, 6 PCLKA	2, 3 ICLK	MTU3a
000C 1A01h	MTU7	Timer Control Register	TCR	8	8	5, 6 PCLKA	2, 3 ICLK	MTU3a
000C 1A02h	MTU6	Timer Mode Register 1	TMDR1	8	8	5, 6 PCLKA	2, 3 ICLK	MTU3a
000C 1A03h	MTU7	Timer Mode Register 1	TMDR1	8	8	5, 6 PCLKA	2, 3 ICLK	MTU3a
000C 1A04h	MTU6	Timer I/O Control Register H	TIORH	8	8	5, 6 PCLKA	2, 3 ICLK	MTU3a

Table 4.1 List of I/O Registers (Address Order) (52 / 70)

Address	Module Symbol	Register Name	Register Symbol	Number of Bits	Access Size	Number of Access Cycles		Related Function
						ICLK ≥ PCLK	ICLK < PCLK	
000C 1A05h	MTU6	Timer I/O Control Register L	TIORL	8	8	5, 6 PCLKA	2, 3 ICLK	MTU3a
000C 1A06h	MTU7	Timer I/O Control Register H	TIORH	8	8	5, 6 PCLKA	2, 3 ICLK	MTU3a
000C 1A07h	MTU7	Timer I/O Control Register L	TIORL	8	8	5, 6 PCLKA	2, 3 ICLK	MTU3a
000C 1A08h	MTU6	Timer Interrupt Enable Register	TIER	8	8	5, 6 PCLKA	2, 3 ICLK	MTU3a
000C 1A09h	MTU7	Timer Interrupt Enable Register	TIER	8	8	5, 6 PCLKA	2, 3 ICLK	MTU3a
000C 1A0Ah	MTU	Timer Output Master Enable Register B	TOERB	8	8	5, 6 PCLKA	2, 3 ICLK	MTU3a
000C 1A0Eh	MTU	Timer Output Control Register 1B	TOCR1B	8	8	5, 6 PCLKA	2, 3 ICLK	MTU3a
000C 1A0Fh	MTU	Timer Output Control Register 2B	TOCR2B	8	8	5, 6 PCLKA	2, 3 ICLK	MTU3a
000C 1A10h	MTU6	Timer Counter	TCNT	16	16	5, 6 PCLKA	2, 3 ICLK	MTU3a
000C 1A12h	MTU7	Timer Counter	TCNT	16	16	5, 6 PCLKA	2, 3 ICLK	MTU3a
000C 1A14h	MTU	Timer Cycle Data Register B	TCDRB	16	16	5, 6 PCLKA	2, 3 ICLK	MTU3a
000C 1A16h	MTU	Timer Dead Time Data Register B	TDDRb	16	16	5, 6 PCLKA	2, 3 ICLK	MTU3a
000C 1A18h	MTU6	Timer General Register A	TGRA	16	16	5, 6 PCLKA	2, 3 ICLK	MTU3a
000C 1A1Ah	MTU6	Timer General Register B	TGRB	16	16	5, 6 PCLKA	2, 3 ICLK	MTU3a
000C 1A1Ch	MTU7	Timer General Register A	TGRA	16	16	5, 6 PCLKA	2, 3 ICLK	MTU3a
000C 1A1Eh	MTU7	Timer General Register B	TGRB	16	16	5, 6 PCLKA	2, 3 ICLK	MTU3a
000C 1A20h	MTU	Timer Subcounter B	TCNTSB	16	16	5, 6 PCLKA	2, 3 ICLK	MTU3a
000C 1A22h	MTU	Timer Cycle Buffer Register B	TCBRB	16	16	5, 6 PCLKA	2, 3 ICLK	MTU3a
000C 1A24h	MTU6	Timer General Register C	TGRC	16	16	5, 6 PCLKA	2, 3 ICLK	MTU3a
000C 1A26h	MTU6	Timer General Register D	TGRD	16	16	5, 6 PCLKA	2, 3 ICLK	MTU3a
000C 1A28h	MTU7	Timer General Register C	TGRC	16	16	5, 6 PCLKA	2, 3 ICLK	MTU3a
000C 1A2Ah	MTU7	Timer General Register D	TGRD	16	16	5, 6 PCLKA	2, 3 ICLK	MTU3a
000C 1A2Ch	MTU6	Timer Status Register	TSR	8	8	5, 6 PCLKA	2, 3 ICLK	MTU3a
000C 1A2Dh	MTU7	Timer Status Register	TSR	8	8	5, 6 PCLKA	2, 3 ICLK	MTU3a
000C 1A30h	MTU	Timer Interrupt Skipping Set Register 1B	TITCR1B	8	8	5, 6 PCLKA	2, 3 ICLK	MTU3a
000C 1A31h	MTU	Timer Interrupt Skipping Counter 1B	TITCNT1B	8	8	5, 6 PCLKA	2, 3 ICLK	MTU3a
000C 1A32h	MTU	Timer Buffer Transfer Set Register B	TBTERB	8	8	5, 6 PCLKA	2, 3 ICLK	MTU3a
000C 1A34h	MTU	Timer Dead Time Enable Register B	TDERB	8	8	5, 6 PCLKA	2, 3 ICLK	MTU3a
000C 1A36h	MTU	Timer Output Level Buffer Register B	TOLBRB	8	8	5, 6 PCLKA	2, 3 ICLK	MTU3a
000C 1A38h	MTU6	Timer Buffer Operation Transfer Mode Register	TBTM	8	8	5, 6 PCLKA	2, 3 ICLK	MTU3a
000C 1A39h	MTU7	Timer Buffer Operation Transfer Mode Register	TBTM	8	8	5, 6 PCLKA	2, 3 ICLK	MTU3a
000C 1A3Ah	MTU	Timer Interrupt Skipping Mode Register B	TITMRB	8	8	5, 6 PCLKA	2, 3 ICLK	MTU3a
000C 1A3Bh	MTU	Timer Interrupt Skipping Set Register 2B	TITCR2B	8	8	5, 6 PCLKA	2, 3 ICLK	MTU3a
000C 1A3Ch	MTU	Timer Interrupt Skipping Counter 2B	TITCNT2B	8	8	5, 6 PCLKA	2, 3 ICLK	MTU3a
000C 1A40h	MTU7	Timer A/D Converter Start Request Control Register	TADCR	16	16	5, 6 PCLKA	2, 3 ICLK	MTU3a
000C 1A44h	MTU7	Timer A/D Converter Start Request Cycle Set Register A	TADCORA	16	16	5, 6 PCLKA	2, 3 ICLK	MTU3a
000C 1A46h	MTU7	Timer A/D Converter Start Request Cycle Set Register B	TADCORB	16	16	5, 6 PCLKA	2, 3 ICLK	MTU3a
000C 1A48h	MTU7	Timer A/D Converter Start Request Cycle Set Buffer Register A	TADCOBRA	16	16	5, 6 PCLKA	2, 3 ICLK	MTU3a
000C 1A4Ah	MTU7	Timer A/D Converter Start Request Cycle Set Buffer Register B	TADCOBRB	16	16	5, 6 PCLKA	2, 3 ICLK	MTU3a
000C 1A4Ch	MTU6	Timer Control Register 2	TCR2	8	8	5, 6 PCLKA	2, 3 ICLK	MTU3a
000C 1A4Dh	MTU7	Timer Control Register 2	TCR2	8	8	5, 6 PCLKA	2, 3 ICLK	MTU3a
000C 1A50h	MTU6	Timer Synchronous Clear Register	TSYCR	8	8	5, 6 PCLKA	2, 3 ICLK	MTU3a
000C 1A60h	MTU	Timer Waveform Control Register B	TWCRB	8	8	5, 6 PCLKA	2, 3 ICLK	MTU3a
000C 1A70h	MTU	Timer Mode Register 2B	TMDR2B	8	8	5, 6 PCLKA	2, 3 ICLK	MTU3a
000C 1A72h	MTU6	Timer General Register E	TGRE	16	16	5, 6 PCLKA	2, 3 ICLK	MTU3a
000C 1A74h	MTU7	Timer General Register E	TGRE	16	16	5, 6 PCLKA	2, 3 ICLK	MTU3a
000C 1A76h	MTU7	Timer General Register F	TGRF	16	16	5, 6 PCLKA	2, 3 ICLK	MTU3a

Table 4.1 List of I/O Registers (Address Order) (53 / 70)

Address	Module Symbol	Register Name	Register Symbol	Number of Bits	Access Size	Number of Access Cycles		Related Function
						ICLK ≥ PCLK	ICLK < PCLK	
000C 1A80h	MTU	Timer Start Register B	TSTRB	8	8	5, 6 PCLKA	2, 3 ICLK	MTU3a
000C 1A81h	MTU	Timer Synchronous Register B	TSYRB	8	8	5, 6 PCLKA	2, 3 ICLK	MTU3a
000C 1A84h	MTU	Timer Read/Write Enable Register B	TRWERB	8	8	5, 6 PCLKA	2, 3 ICLK	MTU3a
000C 1A93h	MTU6	Noise Filter Control Register 6	NFCR6	8	8	5, 6 PCLKA	2, 3 ICLK	MTU3a
000C 1A94h	MTU7	Noise Filter Control Register 7	NFCR7	8	8	5, 6 PCLKA	2, 3 ICLK	MTU3a
000C 1A95h	MTU5	Noise Filter Control Register 5	NFCR5	8	8	5, 6 PCLKA	2, 3 ICLK	MTU3a
000C 1C80h	MTU5	Timer Counter U	TCNTU	16	16	5, 6 PCLKA	2, 3 ICLK	MTU3a
000C 1C82h	MTU5	Timer General Register U	TGRU	16	16	5, 6 PCLKA	2, 3 ICLK	MTU3a
000C 1C84h	MTU5	Timer Control Register U	TCRU	8	8	5, 6 PCLKA	2, 3 ICLK	MTU3a
000C 1C85h	MTU5	Timer Control Register 2	TCR2U	8	8	5, 6 PCLKA	2, 3 ICLK	MTU3a
000C 1C86h	MTU5	Timer I/O Control Register U	TIORU	8	8	5, 6 PCLKA	2, 3 ICLK	MTU3a
000C 1C90h	MTU5	Timer Counter V	TCNTV	16	16	5, 6 PCLKA	2, 3 ICLK	MTU3a
000C 1C92h	MTU5	Timer General Register V	TGRV	16	16	5, 6 PCLKA	2, 3 ICLK	MTU3a
000C 1C94h	MTU5	Timer Control Register V	TCRV	8	8	5, 6 PCLKA	2, 3 ICLK	MTU3a
000C 1C95h	MTU5	Timer Control Register 2	TCR2V	8	8	5, 6 PCLKA	2, 3 ICLK	MTU3a
000C 1C96h	MTU5	Timer I/O Control Register V	TIORV	8	8	5, 6 PCLKA	2, 3 ICLK	MTU3a
000C 1CA0h	MTU5	Timer Counter W	TCNTW	16	16	5, 6 PCLKA	2, 3 ICLK	MTU3a
000C 1CA2h	MTU5	Timer General Register W	TGRW	16	16	5, 6 PCLKA	2, 3 ICLK	MTU3a
000C 1CA4h	MTU5	Timer Control Register W	TCRW	8	8	5, 6 PCLKA	2, 3 ICLK	MTU3a
000C 1CA5h	MTU5	Timer Control Register 2	TCR2W	8	8	5, 6 PCLKA	2, 3 ICLK	MTU3a
000C 1CA6h	MTU5	Timer I/O Control Register W	TIORW	8	8	5, 6 PCLKA	2, 3 ICLK	MTU3a
000C 1CB2h	MTU5	Timer Interrupt Enable Register	TIER	8	8	5, 6 PCLKA	2, 3 ICLK	MTU3a
000C 1CB4h	MTU5	Timer Start Register	TSTR	8	8	5, 6 PCLKA	2, 3 ICLK	MTU3a
000C 1CB6h	MTU5	Timer Compare Match Clear Register	TCNTCMPCLR	8	8	5, 6 PCLKA	2, 3 ICLK	MTU3a
000C 2000h	GPT	General PWM Timer Software Start Register	GTSTR	16	16	4, 5 PCLKA	2, 3 ICLK	GPTA
000C 2002h	GPT	Noise Filter Control Register	NFCR	16	16	4, 5 PCLKA	2, 3 ICLK	GPTA
000C 2004h	GPT	General PWM Timer Hardware Source Start/Stop Control Register	GTHSCR	16	16	4, 5 PCLKA	2, 3 ICLK	GPTA
000C 2006h	GPT	General PWM Timer Hardware Source Clear Control Register	GTHCCR	16	16	4, 5 PCLKA	2, 3 ICLK	GPTA
000C 2008h	GPT	General PWM Timer Hardware Start Source Select Register	GTHSSR	16	16	4, 5 PCLKA	2, 3 ICLK	GPTA
000C 200Ah	GPT	General PWM Timer Hardware Stop/Clear Source Select Register	GTHPSR	16	16	4, 5 PCLKA	2, 3 ICLK	GPTA
000C 200Ch	GPT	General PWM Timer Write-Protection Register	GTWP	16	16	4, 5 PCLKA	2, 3 ICLK	GPTA
000C 200Eh	GPT	General PWM Timer Sync Register	GTSYNC	16	16	4, 5 PCLKA	2, 3 ICLK	GPTA
000C 2010h	GPT	General PWM Timer External Trigger Input Interrupt Register	GTETINT	16	16	4, 5 PCLKA	2, 3 ICLK	GPTA
000C 2014h	GPT	General PWM Timer Buffer Operation Disable Register	GTBDR	16	16	4, 5 PCLKA	2, 3 ICLK	GPTA
000C 2018h	GPT	General PWM Timer Start Write-Protection Register	GTSWP	16	16	4, 5 PCLKA	2, 3 ICLK	GPTA
000C 2100h	GPT0	General PWM Timer I/O Control Register	GTIOR	16	16	4, 5 PCLKA	2, 3 ICLK	GPTA
000C 2102h	GPT0	General PWM Timer Interrupt Output Setting Register	GTINTAD	16	16	4, 5 PCLKA	2, 3 ICLK	GPTA
000C 2104h	GPT0	General PWM Timer Control Register	GTCR	16	16	4, 5 PCLKA	2, 3 ICLK	GPTA
000C 2106h	GPT0	General PWM Timer Buffer Enable Register	GTBER	16	16	4, 5 PCLKA	2, 3 ICLK	GPTA
000C 2108h	GPT0	General PWM Timer Count Direction Register	GTUDC	16	16	4, 5 PCLKA	2, 3 ICLK	GPTA
000C 210Ah	GPT0	General PWM Timer Interrupt and A/D Converter Start Request Skipping Setting Register	GTITC	16	16	4, 5 PCLKA	2, 3 ICLK	GPTA
000C 210Ch	GPT0	General PWM Timer Status Register	GTST	16	16	4, 5 PCLKA	2, 3 ICLK	GPTA
000C 210Eh	GPT0	General PWM Timer Counter	GTCNT	16	16	4, 5 PCLKA	2, 3 ICLK	GPTA
000C 2110h	GPT0	General PWM Timer Compare Capture Register A	GTCCRA	16	16	4, 5 PCLKA	2, 3 ICLK	GPTA
000C 2112h	GPT0	General PWM Timer Compare Capture Register B	GTCCRB	16	16	4, 5 PCLKA	2, 3 ICLK	GPTA

Table 4.1 List of I/O Registers (Address Order) (54 / 70)

Address	Module Symbol	Register Name	Register Symbol	Number of Bits	Access Size	Number of Access Cycles		Related Function
						ICLK ≥ PCLK	ICLK < PCLK	
000C 2114h	GPT0	General PWM Timer Compare Capture Register C	GTCCRC	16	16	4, 5 PCLKA	2, 3 ICLK	GPTA
000C 2116h	GPT0	General PWM Timer Compare Capture Register D	GTCCRD	16	16	4, 5 PCLKA	2, 3 ICLK	GPTA
000C 2118h	GPT0	General PWM Timer Compare Capture Register E	GTCCRE	16	16	4, 5 PCLKA	2, 3 ICLK	GPTA
000C 211Ah	GPT0	General PWM Timer Compare Capture Register F	GTCCRF	16	16	4, 5 PCLKA	2, 3 ICLK	GPTA
000C 211Ch	GPT0	General PWM Timer Cycle Setting Register	GTPR	16	16	4, 5 PCLKA	2, 3 ICLK	GPTA
000C 211Eh	GPT0	General PWM Timer Cycle Setting Buffer Register	GTPBR	16	16	4, 5 PCLKA	2, 3 ICLK	GPTA
000C 2120h	GPT0	General PWM Timer Cycle Setting Double-Buffer Register	GTPDBR	16	16	4, 5 PCLKA	2, 3 ICLK	GPTA
000C 2124h	GPT0	A/D Converter Start Request Timing Register A	GTADTRA	16	16	4, 5 PCLKA	2, 3 ICLK	GPTA
000C 2126h	GPT0	A/D Converter Start Request Timing Buffer Register A	GTADTBRA	16	16	4, 5 PCLKA	2, 3 ICLK	GPTA
000C 2128h	GPT0	A/D Converter Start Request Timing Double-Buffer Register A	GTADTBRA	16	16	4, 5 PCLKA	2, 3 ICLK	GPTA
000C 212Ch	GPT0	A/D Converter Start Request Timing Register B	GTADTRB	16	16	4, 5 PCLKA	2, 3 ICLK	GPTA
000C 212Eh	GPT0	A/D Converter Start Request Timing Buffer Register B	GTADTBRB	16	16	4, 5 PCLKA	2, 3 ICLK	GPTA
000C 2130h	GPT0	A/D Converter Start Request Timing Double-Buffer Register B	GTADTBRB	16	16	4, 5 PCLKA	2, 3 ICLK	GPTA
000C 2134h	GPT0	General PWM Timer Output Negate Control Register	GTONCR	16	16	4, 5 PCLKA	2, 3 ICLK	GPTA
000C 2136h	GPT0	General PWM Timer Dead Time Control Register	GTDTCR	16	16	4, 5 PCLKA	2, 3 ICLK	GPTA
000C 2138h	GPT0	General PWM Timer Dead Time Value Register U	GTDVU	16	16	4, 5 PCLKA	2, 3 ICLK	GPTA
000C 213Ah	GPT0	General PWM Timer Dead Time Value Register D	GTDVD	16	16	4, 5 PCLKA	2, 3 ICLK	GPTA
000C 213Ch	GPT0	General PWM Timer Dead Time Buffer Register U	GTDBU	16	16	4, 5 PCLKA	2, 3 ICLK	GPTA
000C 213Eh	GPT0	General PWM Timer Dead Time Buffer Register D	GTDBD	16	16	4, 5 PCLKA	2, 3 ICLK	GPTA
000C 2140h	GPT0	General PWM Timer Output Protection Function Status Register	GTSOS	16	16	4, 5 PCLKA	2, 3 ICLK	GPTA
000C 2142h	GPT0	General PWM Timer Output Protection Function Temporary Release Register	GTSOTR	16	16	4, 5 PCLKA	2, 3 ICLK	GPTA
000C 2180h	GPT1	General PWM Timer I/O Control Register	GTIOR	16	16	4, 5 PCLKA	2, 3 ICLK	GPTA
000C 2182h	GPT1	General PWM Timer Interrupt Output Setting Register	GTINTAD	16	16	4, 5 PCLKA	2, 3 ICLK	GPTA
000C 2184h	GPT1	General PWM Timer Control Register	GTCR	16	16	4, 5 PCLKA	2, 3 ICLK	GPTA
000C 2186h	GPT1	General PWM Timer Buffer Enable Register	GTBER	16	16	4, 5 PCLKA	2, 3 ICLK	GPTA
000C 2188h	GPT1	General PWM Timer Count Direction Register	GTUDC	16	16	4, 5 PCLKA	2, 3 ICLK	GPTA
000C 218Ah	GPT1	General PWM Timer Interrupt and A/D Converter Start Request Skipping Setting Register	GTITC	16	16	4, 5 PCLKA	2, 3 ICLK	GPTA
000C 218Ch	GPT1	General PWM Timer Status Register	GTST	16	16	4, 5 PCLKA	2, 3 ICLK	GPTA
000C 218Eh	GPT1	General PWM Timer Counter	GTCNT	16	16	4, 5 PCLKA	2, 3 ICLK	GPTA
000C 2190h	GPT1	General PWM Timer Compare Capture Register A	GTCCRA	16	16	4, 5 PCLKA	2, 3 ICLK	GPTA
000C 2192h	GPT1	General PWM Timer Compare Capture Register B	GTCCRB	16	16	4, 5 PCLKA	2, 3 ICLK	GPTA
000C 2194h	GPT1	General PWM Timer Compare Capture Register C	GTCCRC	16	16	4, 5 PCLKA	2, 3 ICLK	GPTA
000C 2196h	GPT1	General PWM Timer Compare Capture Register D	GTCCRD	16	16	4, 5 PCLKA	2, 3 ICLK	GPTA
000C 2198h	GPT1	General PWM Timer Compare Capture Register E	GTCCRE	16	16	4, 5 PCLKA	2, 3 ICLK	GPTA
000C 219Ah	GPT1	General PWM Timer Compare Capture Register F	GTCCRF	16	16	4, 5 PCLKA	2, 3 ICLK	GPTA
000C 219Ch	GPT1	General PWM Timer Cycle Setting Register	GTPR	16	16	4, 5 PCLKA	2, 3 ICLK	GPTA
000C 219Eh	GPT1	General PWM Timer Cycle Setting Buffer Register	GTPBR	16	16	4, 5 PCLKA	2, 3 ICLK	GPTA
000C 21A0h	GPT1	General PWM Timer Cycle Setting Double-Buffer Register	GTPDBR	16	16	4, 5 PCLKA	2, 3 ICLK	GPTA
000C 21A4h	GPT1	A/D Converter Start Request Timing Register A	GTADTRA	16	16	4, 5 PCLKA	2, 3 ICLK	GPTA
000C 21A6h	GPT1	A/D Converter Start Request Timing Buffer Register A	GTADTBRA	16	16	4, 5 PCLKA	2, 3 ICLK	GPTA
000C 21A8h	GPT1	A/D Converter Start Request Timing Double-Buffer Register A	GTADTBRA	16	16	4, 5 PCLKA	2, 3 ICLK	GPTA
000C 21ACh	GPT1	A/D Converter Start Request Timing Register B	GTADTRB	16	16	4, 5 PCLKA	2, 3 ICLK	GPTA
000C 21AEh	GPT1	A/D Converter Start Request Timing Buffer Register B	GTADTBRB	16	16	4, 5 PCLKA	2, 3 ICLK	GPTA
000C 21B0h	GPT1	A/D Converter Start Request Timing Double-Buffer Register B	GTADTBRB	16	16	4, 5 PCLKA	2, 3 ICLK	GPTA
000C 21B4h	GPT1	General PWM Timer Output Negate Control Register	GTONCR	16	16	4, 5 PCLKA	2, 3 ICLK	GPTA

Table 4.1 List of I/O Registers (Address Order) (55 / 70)

Address	Module Symbol	Register Name	Register Symbol	Number of Bits	Access Size	Number of Access Cycles		Related Function
						ICLK ≥ PCLK	ICLK < PCLK	
000C 21B6h	GPT1	General PWM Timer Dead Time Control Register	GTDTCR	16	16	4, 5 PCLKA	2, 3 ICLK	GPTA
000C 21B8h	GPT1	General PWM Timer Dead Time Value Register U	GTDVU	16	16	4, 5 PCLKA	2, 3 ICLK	GPTA
000C 21BAh	GPT1	General PWM Timer Dead Time Value Register D	GTDVD	16	16	4, 5 PCLKA	2, 3 ICLK	GPTA
000C 21BCh	GPT1	General PWM Timer Dead Time Buffer Register U	GTDBU	16	16	4, 5 PCLKA	2, 3 ICLK	GPTA
000C 21BEh	GPT1	General PWM Timer Dead Time Buffer Register D	GTDBD	16	16	4, 5 PCLKA	2, 3 ICLK	GPTA
000C 21C0h	GPT1	General PWM Timer Output Protection Function Status Register	GTSOS	16	16	4, 5 PCLKA	2, 3 ICLK	GPTA
000C 21C2h	GPT1	General PWM Timer Output Protection Function Temporary Release Register	GTSOTR	16	16	4, 5 PCLKA	2, 3 ICLK	GPTA
000C 2200h	GPT2	General PWM Timer I/O Control Register	GTIOR	16	16	4, 5 PCLKA	2, 3 ICLK	GPTA
000C 2202h	GPT2	General PWM Timer Interrupt Output Setting Register	GTINTAD	16	16	4, 5 PCLKA	2, 3 ICLK	GPTA
000C 2204h	GPT2	General PWM Timer Control Register	GTCR	16	16	4, 5 PCLKA	2, 3 ICLK	GPTA
000C 2206h	GPT2	General PWM Timer Buffer Enable Register	GTBER	16	16	4, 5 PCLKA	2, 3 ICLK	GPTA
000C 2208h	GPT2	General PWM Timer Count Direction Register	GTUDC	16	16	4, 5 PCLKA	2, 3 ICLK	GPTA
000C 220Ah	GPT2	General PWM Timer Interrupt and A/D Converter Start Request Skipping Setting Register	GTITC	16	16	4, 5 PCLKA	2, 3 ICLK	GPTA
000C 220Ch	GPT2	General PWM Timer Status Register	GTST	16	16	4, 5 PCLKA	2, 3 ICLK	GPTA
000C 220Eh	GPT2	General PWM Timer Counter	GTCNT	16	16	4, 5 PCLKA	2, 3 ICLK	GPTA
000C 2210h	GPT2	General PWM Timer Compare Capture Register A	GTCCRA	16	16	4, 5 PCLKA	2, 3 ICLK	GPTA
000C 2212h	GPT2	General PWM Timer Compare Capture Register B	GTCCRB	16	16	4, 5 PCLKA	2, 3 ICLK	GPTA
000C 2214h	GPT2	General PWM Timer Compare Capture Register C	GTCCRC	16	16	4, 5 PCLKA	2, 3 ICLK	GPTA
000C 2216h	GPT2	General PWM Timer Compare Capture Register D	GTCCRD	16	16	4, 5 PCLKA	2, 3 ICLK	GPTA
000C 2218h	GPT2	General PWM Timer Compare Capture Register E	GTCCRE	16	16	4, 5 PCLKA	2, 3 ICLK	GPTA
000C 221Ah	GPT2	General PWM Timer Compare Capture Register F	GTCCRF	16	16	4, 5 PCLKA	2, 3 ICLK	GPTA
000C 221Ch	GPT2	General PWM Timer Cycle Setting Register	GTPR	16	16	4, 5 PCLKA	2, 3 ICLK	GPTA
000C 221Eh	GPT2	General PWM Timer Cycle Setting Buffer Register	GTPBR	16	16	4, 5 PCLKA	2, 3 ICLK	GPTA
000C 2220h	GPT2	General PWM Timer Cycle Setting Double-Buffer Register	GTPDBR	16	16	4, 5 PCLKA	2, 3 ICLK	GPTA
000C 2224h	GPT2	A/D Converter Start Request Timing Register A	GTADTRA	16	16	4, 5 PCLKA	2, 3 ICLK	GPTA
000C 2226h	GPT2	A/D Converter Start Request Timing Buffer Register A	GTADTBRA	16	16	4, 5 PCLKA	2, 3 ICLK	GPTA
000C 2228h	GPT2	A/D Converter Start Request Timing Double-Buffer Register A	GTADTBRA	16	16	4, 5 PCLKA	2, 3 ICLK	GPTA
000C 222Ch	GPT2	A/D Converter Start Request Timing Register B	GTADTRB	16	16	4, 5 PCLKA	2, 3 ICLK	GPTA
000C 222Eh	GPT2	A/D Converter Start Request Timing Buffer Register B	GTADTRB	16	16	4, 5 PCLKA	2, 3 ICLK	GPTA
000C 2230h	GPT2	A/D Converter Start Request Timing Double-Buffer Register B	GTADTRB	16	16	4, 5 PCLKA	2, 3 ICLK	GPTA
000C 2234h	GPT2	General PWM Timer Output Negate Control Register	GTONCR	16	16	4, 5 PCLKA	2, 3 ICLK	GPTA
000C 2236h	GPT2	General PWM Timer Dead Time Control Register	GTDTCR	16	16	4, 5 PCLKA	2, 3 ICLK	GPTA
000C 2238h	GPT2	General PWM Timer Dead Time Value Register U	GTDVU	16	16	4, 5 PCLKA	2, 3 ICLK	GPTA
000C 223Ah	GPT2	General PWM Timer Dead Time Value Register D	GTDVD	16	16	4, 5 PCLKA	2, 3 ICLK	GPTA
000C 223Ch	GPT2	General PWM Timer Dead Time Buffer Register U	GTDBU	16	16	4, 5 PCLKA	2, 3 ICLK	GPTA
000C 223Eh	GPT2	General PWM Timer Dead Time Buffer Register D	GTDBD	16	16	4, 5 PCLKA	2, 3 ICLK	GPTA
000C 2240h	GPT2	General PWM Timer Output Protection Function Status Register	GTSOS	16	16	4, 5 PCLKA	2, 3 ICLK	GPTA
000C 2242h	GPT2	General PWM Timer Output Protection Function Temporary Release Register	GTSOTR	16	16	4, 5 PCLKA	2, 3 ICLK	GPTA
000C 2280h	GPT3	General PWM Timer I/O Control Register	GTIOR	16	16	4, 5 PCLKA	2, 3 ICLK	GPTA
000C 2282h	GPT3	General PWM Timer Interrupt Output Setting Register	GTINTAD	16	16	4, 5 PCLKA	2, 3 ICLK	GPTA
000C 2284h	GPT3	General PWM Timer Control Register	GTCR	16	16	4, 5 PCLKA	2, 3 ICLK	GPTA
000C 2286h	GPT3	General PWM Timer Buffer Enable Register	GTBER	16	16	4, 5 PCLKA	2, 3 ICLK	GPTA
000C 2288h	GPT3	General PWM Timer Count Direction Register	GTUDC	16	16	4, 5 PCLKA	2, 3 ICLK	GPTA
000C 228Ah	GPT3	General PWM Timer Interrupt and A/D Converter Start Request Skipping Setting Register	GTITC	16	16	4, 5 PCLKA	2, 3 ICLK	GPTA
000C 228Ch	GPT3	General PWM Timer Status Register	GTST	16	16	4, 5 PCLKA	2, 3 ICLK	GPTA

Table 4.1 List of I/O Registers (Address Order) (56 / 70)

Address	Module Symbol	Register Name	Register Symbol	Number of Bits	Access Size	Number of Access Cycles		Related Function
						ICLK ≥ PCLK	ICLK < PCLK	
000C 228Eh	GPT3	General PWM Timer Counter	GTCNT	16	16	4, 5 PCLKA	2, 3 ICLK	GPTA
000C 2290h	GPT3	General PWM Timer Compare Capture Register A	GTCCRA	16	16	4, 5 PCLKA	2, 3 ICLK	GPTA
000C 2292h	GPT3	General PWM Timer Compare Capture Register B	GTCCRB	16	16	4, 5 PCLKA	2, 3 ICLK	GPTA
000C 2294h	GPT3	General PWM Timer Compare Capture Register C	GTCCRC	16	16	4, 5 PCLKA	2, 3 ICLK	GPTA
000C 2296h	GPT3	General PWM Timer Compare Capture Register D	GTCCRD	16	16	4, 5 PCLKA	2, 3 ICLK	GPTA
000C 2298h	GPT3	General PWM Timer Compare Capture Register E	GTCCRE	16	16	4, 5 PCLKA	2, 3 ICLK	GPTA
000C 229Ah	GPT3	General PWM Timer Compare Capture Register F	GTCCRF	16	16	4, 5 PCLKA	2, 3 ICLK	GPTA
000C 229Ch	GPT3	General PWM Timer Cycle Setting Register	GTPR	16	16	4, 5 PCLKA	2, 3 ICLK	GPTA
000C 229Eh	GPT3	General PWM Timer Cycle Setting Buffer Register	GTPBR	16	16	4, 5 PCLKA	2, 3 ICLK	GPTA
000C 22A0h	GPT3	General PWM Timer Cycle Setting Double-Buffer Register	GTPDBR	16	16	4, 5 PCLKA	2, 3 ICLK	GPTA
000C 22A4h	GPT3	A/D Converter Start Request Timing Register A	GTADTRA	16	16	4, 5 PCLKA	2, 3 ICLK	GPTA
000C 22A6h	GPT3	A/D Converter Start Request Timing Buffer Register A	GTADTBRA	16	16	4, 5 PCLKA	2, 3 ICLK	GPTA
000C 22A8h	GPT3	A/D Converter Start Request Timing Double-Buffer Register A	GTADTBRA	16	16	4, 5 PCLKA	2, 3 ICLK	GPTA
000C 22ACh	GPT3	A/D Converter Start Request Timing Register B	GTADTRB	16	16	4, 5 PCLKA	2, 3 ICLK	GPTA
000C 22AEh	GPT3	A/D Converter Start Request Timing Buffer Register B	GTADTB RB	16	16	4, 5 PCLKA	2, 3 ICLK	GPTA
000C 22B0h	GPT3	A/D Converter Start Request Timing Double-Buffer Register B	GTADTB RB	16	16	4, 5 PCLKA	2, 3 ICLK	GPTA
000C 22B4h	GPT3	General PWM Timer Output Negate Control Register	GTONCR	16	16	4, 5 PCLKA	2, 3 ICLK	GPTA
000C 22B6h	GPT3	General PWM Timer Dead Time Control Register	GTDTCR	16	16	4, 5 PCLKA	2, 3 ICLK	GPTA
000C 22B8h	GPT3	General PWM Timer Dead Time Value Register U	GTDVU	16	16	4, 5 PCLKA	2, 3 ICLK	GPTA
000C 22BAh	GPT3	General PWM Timer Dead Time Value Register D	GTDVD	16	16	4, 5 PCLKA	2, 3 ICLK	GPTA
000C 22BCh	GPT3	General PWM Timer Dead Time Buffer Register U	GTDBU	16	16	4, 5 PCLKA	2, 3 ICLK	GPTA
000C 22BEh	GPT3	General PWM Timer Dead Time Buffer Register D	GTDBD	16	16	4, 5 PCLKA	2, 3 ICLK	GPTA
000C 22C0h	GPT3	General PWM Timer Output Protection Function Status Register	GTSOS	16	16	4, 5 PCLKA	2, 3 ICLK	GPTA
000C 22C2h	GPT3	General PWM Timer Output Protection Function Temporary Release Register	GTSOTR	16	16	4, 5 PCLKA	2, 3 ICLK	GPTA
000C 4000h	EPTPC	MINT Interrupt Source Status Register	MIESR	32	32	5, 6 PCLKA	2, 3 ICLK	EPTPC a
000C 4004h	EPTPC	MINT Interrupt Request Permission Register	MIEIPR	32	32	5, 6 PCLKA	2, 3 ICLK	EPTPC a
000C 4010h	EPTPC	ELC Output/IPLS Interrupt Request Permission Register	ELIPPR	32	32	5, 6 PCLKA	2, 3 ICLK	EPTPC a
000C 4014h	EPTPC	ELC Output/IPLS Interrupt Permission Automatic Clearing Register	ELIPACR	32	32	5, 6 PCLKA	2, 3 ICLK	EPTPC a
000C 4040h	EPTPC	STCA Status Register	STSR	32	32	8 to 43 PCLKA	2 to 22 ICLK	EPTPC a
000C 4044h	EPTPC	STCA Status Notification Permission Register	STIPR	32	32	8 to 43 PCLKA	2 to 22 ICLK	EPTPC a
000C 4050h	EPTPC	STCA Clock Frequency Setting Register	STCFR	32	32	8 to 43 PCLKA	2 to 22 ICLK	EPTPC a
000C 4054h	EPTPC	STCA Operating Mode Register	STMR	32	32	8 to 43 PCLKA	2 to 22 ICLK	EPTPC a
000C 4058h	EPTPC	Sync Message Reception Timeout Register	SYNTOR	32	32	8 to 43 PCLKA	2 to 22 ICLK	EPTPC a
000C 4060h	EPTPC	IPLS Interrupt Request Timer Select Register	IPTSELR	32	32	8 to 43 PCLKA	2 to 22 ICLK	EPTPC a
000C 4064h	EPTPC	MINT Interrupt Request Timer Select Register	MITSELR	32	32	8 to 43 PCLKA	2 to 22 ICLK	EPTPC a
000C 4068h	EPTPC	ELC Output Timer Select Register	ELTSELR	32	32	8 to 43 PCLKA	2 to 22 ICLK	EPTPC a
000C 406Ch	EPTPC	Time Synchronization Channel Select Register	STCHSELR	32	32	8 to 43 PCLKA	2 to 22 ICLK	EPTPC a
000C 4080h	EPTPC	Slave Time Synchronization Start Register	SYNSTARTR	32	32	8 to 43 PCLKA	2 to 22 ICLK	EPTPC a

Table 4.1 List of I/O Registers (Address Order) (57 / 70)

Address	Module Symbol	Register Name	Register Symbol	Number of Bits	Access Size	Number of Access Cycles		Related Function
						ICLK ≥ PCLK	ICLK < PCLK	
000C 4084h	EPTPC	Local Time Counter Initial Value Load Directive Register	LCIVLDR	32	32	8 to 43 PCLKA	2 to 22 ICLK	EPTPC a
000C 4090h	EPTPC	Synchronization Loss Detection Threshold Register	SYNTDARU	32	32	8 to 43 PCLKA	2 to 22 ICLK	EPTPC a
000C 4094h	EPTPC	Synchronization Loss Detection Threshold Register	SYNTDARL	32	32	8 to 43 PCLKA	2 to 22 ICLK	EPTPC a
000C 4098h	EPTPC	Synchronization Detection Threshold Register	SYNTDBRU	32	32	8 to 43 PCLKA	2 to 22 ICLK	EPTPC a
000C 409Ch	EPTPC	Synchronization Detection Threshold Register	SYNTDBRL	32	32	8 to 43 PCLKA	2 to 22 ICLK	EPTPC a
000C 40B0h	EPTPC	Local Time Counter Initial Value Register	LCIVRU	32	32	8 to 43 PCLKA	2 to 22 ICLK	EPTPC a
000C 40B4h	EPTPC	Local Time Counter Initial Value Register	LCIVRM	32	32	8 to 43 PCLKA	2 to 22 ICLK	EPTPC a
000C 40B8h	EPTPC	Local Time Counter Initial Value Register	LCIVRL	32	32	8 to 43 PCLKA	2 to 22 ICLK	EPTPC a
000C 4124h	EPTPC	Worst 10 Acquisition Directive Register	GETW10R	32	32	8 to 43 PCLKA	2 to 22 ICLK	EPTPC a
000C 4128h	EPTPC	Positive Gradient Limit Register	PLIMITRU	32	32	8 to 43 PCLKA	2 to 22 ICLK	EPTPC a
000C 412Ch	EPTPC	Positive Gradient Limit Register	PLIMITRM	32	32	8 to 43 PCLKA	2 to 22 ICLK	EPTPC a
000C 4130h	EPTPC	Positive Gradient Limit Register	PLIMITRL	32	32	8 to 43 PCLKA	2 to 22 ICLK	EPTPC a
000C 4134h	EPTPC	Negative Gradient Limit Register	MLIMITRU	32	32	8 to 43 PCLKA	2 to 22 ICLK	EPTPC a
000C 4138h	EPTPC	Negative Gradient Limit Register	MLIMITRM	32	32	8 to 43 PCLKA	2 to 22 ICLK	EPTPC a
000C 413Ch	EPTPC	Negative Gradient Limit Register	MLIMITRL	32	32	8 to 43 PCLKA	2 to 22 ICLK	EPTPC a
000C 4140h	EPTPC	Statistical Information Retention Control Register	GETINFOR	32	32	8 to 43 PCLKA	2 to 22 ICLK	EPTPC a
000C 4170h	EPTPC	Local Time Counter	LCCVRU	32	32	8 to 43 PCLKA	2 to 22 ICLK	EPTPC a
000C 4174h	EPTPC	Local Time Counter	LCCVRM	32	32	8 to 43 PCLKA	2 to 22 ICLK	EPTPC a
000C 4178h	EPTPC	Local Time Counter	LCCVRL	32	32	8 to 43 PCLKA	2 to 22 ICLK	EPTPC a
000C 4210h	EPTPC	Positive Gradient Worst 10 Value Register	PW10VRU	32	32	8 to 43 PCLKA	2 to 22 ICLK	EPTPC a
000C 4214h	EPTPC	Positive Gradient Worst 10 Value Register	PW10VRM	32	32	8 to 43 PCLKA	2 to 22 ICLK	EPTPC a
000C 4218h	EPTPC	Positive Gradient Worst 10 Value Register	PW10VRL	32	32	8 to 43 PCLKA	2 to 22 ICLK	EPTPC a
000C 42D0h	EPTPC	Negative Gradient Worst 10 Value Register	MW10RU	32	32	8 to 43 PCLKA	2 to 22 ICLK	EPTPC a
000C 42D4h	EPTPC	Negative Gradient Worst 10 Value Register	MW10RM	32	32	8 to 43 PCLKA	2 to 22 ICLK	EPTPC a
000C 42D8h	EPTPC	Negative Gradient Worst 10 Value Register	MW10RL	32	32	8 to 43 PCLKA	2 to 22 ICLK	EPTPC a
000C 4300h	EPTPC	Timer Start Time Setting Register	TMSTTRU0	32	32	8 to 43 PCLKA	2 to 22 ICLK	EPTPC a
000C 4304h	EPTPC	Timer Start Time Setting Register	TMSTTRL0	32	32	8 to 43 PCLKA	2 to 22 ICLK	EPTPC a
000C 4308h	EPTPC	Timer Cycle Setting Register 0	TMCYCR0	32	32	8 to 43 PCLKA	2 to 22 ICLK	EPTPC a
000C 430Ch	EPTPC	Timer Pulse Width Setting Register 0	TMPLSR0	32	32	8 to 43 PCLKA	2 to 22 ICLK	EPTPC a
000C 4310h	EPTPC	Timer Start Time Setting Register	TMSTTRU1	32	32	8 to 43 PCLKA	2 to 22 ICLK	EPTPC a
000C 4314h	EPTPC	Timer Start Time Setting Register	TMSTTRL1	32	32	8 to 43 PCLKA	2 to 22 ICLK	EPTPC a

Table 4.1 List of I/O Registers (Address Order) (58 / 70)

Address	Module Symbol	Register Name	Register Symbol	Number of Bits	Access Size	Number of Access Cycles		Related Function
						ICLK ≥ PCLK	ICLK < PCLK	
000C 4318h	EPTPC	Timer Cycle Setting Register 1	TMCYCR1	32	32	8 to 43 PCLKA	2 to 22 ICLK	EPTPCa
000C 431Ch	EPTPC	Timer Pulse Width Setting Register 1	TMPLSR1	32	32	8 to 43 PCLKA	2 to 22 ICLK	EPTPCa
000C 4320h	EPTPC	Timer Start Time Setting Register	TMSTTRU2	32	32	8 to 43 PCLKA	2 to 22 ICLK	EPTPCa
000C 4324h	EPTPC	Timer Start Time Setting Register	TMSTTRL2	32	32	8 to 43 PCLKA	2 to 22 ICLK	EPTPCa
000C 4328h	EPTPC	Timer Cycle Setting Register 2	TMCYCR2	32	32	8 to 43 PCLKA	2 to 22 ICLK	EPTPCa
000C 432Ch	EPTPC	Timer Pulse Width Setting Register 2	TMPLSR2	32	32	8 to 43 PCLKA	2 to 22 ICLK	EPTPCa
000C 4330h	EPTPC	Timer Start Time Setting Register	TMSTTRU3	32	32	8 to 43 PCLKA	2 to 22 ICLK	EPTPCa
000C 4334h	EPTPC	Timer Start Time Setting Register	TMSTTRL3	32	32	8 to 43 PCLKA	2 to 22 ICLK	EPTPCa
000C 4338h	EPTPC	Timer Cycle Setting Register 3	TMCYCR3	32	32	8 to 43 PCLKA	2 to 22 ICLK	EPTPCa
000C 433Ch	EPTPC	Timer Pulse Width Setting Register 3	TMPLSR3	32	32	8 to 43 PCLKA	2 to 22 ICLK	EPTPCa
000C 4340h	EPTPC	Timer Start Time Setting Register	TMSTTRU4	32	32	8 to 43 PCLKA	2 to 22 ICLK	EPTPCa
000C 4344h	EPTPC	Timer Start Time Setting Register	TMSTTRL4	32	32	8 to 43 PCLKA	2 to 22 ICLK	EPTPCa
000C 4348h	EPTPC	Timer Cycle Setting Register 4	TMCYCR4	32	32	8 to 43 PCLKA	2 to 22 ICLK	EPTPCa
000C 434Ch	EPTPC	Timer Pulse Width Setting Register 4	TMPLSR4	32	32	8 to 43 PCLKA	2 to 22 ICLK	EPTPCa
000C 4350h	EPTPC	Timer Start Time Setting Register	TMSTTRU5	32	32	8 to 43 PCLKA	2 to 22 ICLK	EPTPCa
000C 4354h	EPTPC	Timer Start Time Setting Register	TMSTTRL5	32	32	8 to 43 PCLKA	2 to 22 ICLK	EPTPCa
000C 4358h	EPTPC	Timer Cycle Setting Register 5	TMCYCR5	32	32	8 to 43 PCLKA	2 to 22 ICLK	EPTPCa
000C 435Ch	EPTPC	Timer Pulse Width Setting Register 5	TMPLSR5	32	32	8 to 43 PCLKA	2 to 22 ICLK	EPTPCa
000C 437Ch	EPTPC	Timer Start Register	TMSTARTR	32	32	8 to 43 PCLKA	2 to 22 ICLK	EPTPCa
000C 4400h	EPTPC	PRC-TC Status Register	PRSR	32	32	9, 10 PCLKA	2 to 5 ICLK	EPTPCa
000C 4404h	EPTPC	PRC-TC Status Notification Permission Register	PRIPR	32	32	9, 10 PCLKA	2 to 5 ICLK	EPTPCa
000C 4410h	EPTPC	Channel 0 Local MAC Address Register	PRMACRU0	32	32	9, 10 PCLKA	2 to 5 ICLK	EPTPCa
000C 4414h	EPTPC	Channel 0 Local MAC Address Register	PRMACRL0	32	32	9, 10 PCLKA	2 to 5 ICLK	EPTPCa
000C 4418h	EPTPC	Channel 1 Local MAC Address Register	PRMACRU1	32	32	9, 10 PCLKA	2 to 5 ICLK	EPTPCa
000C 441Ch	EPTPC	Channel 1 Local MAC Address Register	PRMACRL1	32	32	9, 10 PCLKA	2 to 5 ICLK	EPTPCa
000C 4420h	EPTPC	Packet Transmission Control Register	TRNDISR	32	32	9, 10 PCLKA	2 to 5 ICLK	EPTPCa
000C 4430h	EPTPC	Relay Mode Register	TRNMR	32	32	9, 10 PCLKA	2 to 5 ICLK	EPTPCa
000C 4434h	EPTPC	Cut-Through Transfer Start Threshold Register	TRNCTTDR	32	32	9, 10 PCLKA	2 to 5 ICLK	EPTPCa
000C 4800h	EPTPC0	SYNFP Status Register	SYSR	32	32	9 to 211 PCLKA	2 to 106 ICLK	EPTPCa
000C 4804h	EPTPC0	SYNFP Status Notification Permission Register	SYIPR	32	32	9 to 211 PCLKA	2 to 106 ICLK	EPTPCa
000C 4810h	EPTPC0	SYNFP MAC Address Register	SYMACRU	32	32	9 to 211 PCLKA	2 to 106 ICLK	EPTPCa

Table 4.1 List of I/O Registers (Address Order) (59 / 70)

Address	Module Symbol	Register Name	Register Symbol	Number of Bits	Access Size	Number of Access Cycles		Related Function
						ICLK ≥ PCLK	ICLK < PCLK	
000C 4814h	EPTPC 0	SYNFP MAC Address Register	SYMACRL	32	32	9 to 211 PCLKA	2 to 106 ICLK	EPTPC a
000C 4818h	EPTPC 0	SYNFP LLC-CTL Value Register	SYLLCCTLR	32	32	9 to 211 PCLKA	2 to 106 ICLK	EPTPC a
000C 481Ch	EPTPC 0	SYNFP Local IP Address Register	SYIPADDRR	32	32	9 to 211 PCLKA	2 to 106 ICLK	EPTPC a
000C 4840h	EPTPC 0	SYNFP Specification Version Setting Register	SYSPVRR	32	32	9 to 211 PCLKA	2 to 106 ICLK	EPTPC a
000C 4844h	EPTPC 0	SYNFP Domain Number Setting Register	SYDOMR	32	32	9 to 211 PCLKA	2 to 106 ICLK	EPTPC a
000C 4850h	EPTPC 0	Announce Message Flag Field Setting Register	ANFR	32	32	9 to 211 PCLKA	2 to 106 ICLK	EPTPC a
000C 4854h	EPTPC 0	Sync Message Flag Field Setting Register	SYNFR	32	32	9 to 211 PCLKA	2 to 106 ICLK	EPTPC a
000C 4858h	EPTPC 0	Delay_Req Message Flag Field Setting Register	DYRQFR	32	32	9 to 211 PCLKA	2 to 106 ICLK	EPTPC a
000C 485Ch	EPTPC 0	Delay_Resp Message Flag Field Setting Register	DYRPFRR	32	32	9 to 211 PCLKA	2 to 106 ICLK	EPTPC a
000C 4860h	EPTPC 0	SYNFP Local Clock ID Registers	SYCIDRU	32	32	9 to 211 PCLKA	2 to 106 ICLK	EPTPC a
000C 4864h	EPTPC 0	SYNFP Local Clock ID Registers	SYCIDRL	32	32	9 to 211 PCLKA	2 to 106 ICLK	EPTPC a
000C 4868h	EPTPC 0	SYNFP Local Port Number Register	SYPNUMR	32	32	9 to 211 PCLKA	2 to 106 ICLK	EPTPC a
000C 4880h	EPTPC 0	SYNFP Register Value Load Directive Register	SYRVLDR	32	32	9 to 211 PCLKA	2 to 106 ICLK	EPTPC a
000C 4890h	EPTPC 0	SYNFP Reception Filter Register 1	SYRFL1R	32	32	9 to 211 PCLKA	2 to 106 ICLK	EPTPC a
000C 4894h	EPTPC 0	SYNFP Reception Filter Register 2	SYRFL2R	32	32	9 to 211 PCLKA	2 to 106 ICLK	EPTPC a
000C 4898h	EPTPC 0	SYNFP Transmission Enable Register	SYTRENRR	32	32	9 to 211 PCLKA	2 to 106 ICLK	EPTPC a
000C 48A0h	EPTPC 0	Master Clock ID Register	MTCIDU	32	32	9 to 211 PCLKA	2 to 106 ICLK	EPTPC a
000C 48A4h	EPTPC 0	Master Clock ID Register	MTCIDL	32	32	9 to 211 PCLKA	2 to 106 ICLK	EPTPC a
000C 48A8h	EPTPC 0	Master Clock Port Number Register	MTPID	32	32	9 to 211 PCLKA	2 to 106 ICLK	EPTPC a
000C 48C0h	EPTPC 0	SYNFP Transmission Interval Setting Register	SYTLIR	32	32	9 to 211 PCLKA	2 to 106 ICLK	EPTPC a
000C 48C4h	EPTPC 0	SYNFP Received logMessageInterval Value Indication Register	SYRLIR	32	32	9 to 211 PCLKA	2 to 106 ICLK	EPTPC a
000C 48C8h	EPTPC 0	offsetFromMaster Value Register	OFMRU	32	32	9 to 211 PCLKA	2 to 106 ICLK	EPTPC a
000C 48CCh	EPTPC 0	offsetFromMaster Value Register	OFMRL	32	32	9 to 211 PCLKA	2 to 106 ICLK	EPTPC a
000C 48D0h	EPTPC 0	meanPathDelay Value Register	MPDRU	32	32	9 to 211 PCLKA	2 to 106 ICLK	EPTPC a
000C 48D4h	EPTPC 0	meanPathDelay Value Register	MPDRL	32	32	9 to 211 PCLKA	2 to 106 ICLK	EPTPC a
000C 48E0h	EPTPC 0	grandmasterPriority Field Setting Register	GMPR	32	32	9 to 211 PCLKA	2 to 106 ICLK	EPTPC a
000C 48E4h	EPTPC 0	grandmasterClockQuality Field Setting Register	GMCQR	32	32	9 to 211 PCLKA	2 to 106 ICLK	EPTPC a
000C 48E8h	EPTPC 0	grandmasterIdentity Field Setting Registers	GMIDRU	32	32	9 to 211 PCLKA	2 to 106 ICLK	EPTPC a
000C 48ECh	EPTPC 0	grandmasterIdentity Field Setting Registers	GMIDRL	32	32	9 to 211 PCLKA	2 to 106 ICLK	EPTPC a
000C 48F0h	EPTPC 0	currentUtcOffset/timeSource Field Setting Register	CUOTSR	32	32	9 to 211 PCLKA	2 to 106 ICLK	EPTPC a
000C 48F4h	EPTPC 0	stepsRemoved Field Setting Register	SRR	32	32	9 to 211 PCLKA	2 to 106 ICLK	EPTPC a

Table 4.1 List of I/O Registers (Address Order) (60 / 70)

Address	Module Symbol	Register Name	Register Symbol	Number of Bits	Access Size	Number of Access Cycles		Related Function
						ICLK ≥ PCLK	ICLK < PCLK	
000C 4900h	EPTPC 0	PTP-primary Message Destination MAC Address Setting Registers	PPMACRU	32	32	9 to 211 PCLKA	2 to 106 ICLK	EPTPC a
000C 4904h	EPTPC 0	PTP-primary Message Destination MAC Address Setting Registers	PPMACRL	32	32	9 to 211 PCLKA	2 to 106 ICLK	EPTPC a
000C 4908h	EPTPC 0	PTP-pdelay Message MAC Address Setting Registers	PDMACRU	32	32	9 to 211 PCLKA	2 to 106 ICLK	EPTPC a
000C 490Ch	EPTPC 0	PTP-pdelay Message MAC Address Setting Registers	PDMACRL	32	32	9 to 211 PCLKA	2 to 106 ICLK	EPTPC a
000C 4910h	EPTPC 0	PTP Message EtherType Setting Register	PETYPER	32	32	9 to 211 PCLKA	2 to 106 ICLK	EPTPC a
000C 4920h	EPTPC 0	PTP-primary Message Destination IP Address Setting Register	PPIPR	32	32	9 to 211 PCLKA	2 to 106 ICLK	EPTPC a
000C 4924h	EPTPC 0	PTP-pdelay Message Destination IP Address Setting Register	PDIPR	32	32	9 to 211 PCLKA	2 to 106 ICLK	EPTPC a
000C 4928h	EPTPC 0	PTP event Message TOS Setting Register	PETOSR	32	32	9 to 211 PCLKA	2 to 106 ICLK	EPTPC a
000C 492Ch	EPTPC 0	PTP general Message TOS Setting Register	PGTOSR	32	32	9 to 211 PCLKA	2 to 106 ICLK	EPTPC a
000C 4930h	EPTPC 0	PTP-primary Message TTL Setting Register	PPTTLR	32	32	9 to 211 PCLKA	2 to 106 ICLK	EPTPC a
000C 4934h	EPTPC 0	PTP-pdelay Message TTL Setting Register	PDTTLR	32	32	9 to 211 PCLKA	2 to 106 ICLK	EPTPC a
000C 4938h	EPTPC 0	PTP event Message UDP Destination Port Number Setting Register	PEUDPR	32	32	9 to 211 PCLKA	2 to 106 ICLK	EPTPC a
000C 493Ch	EPTPC 0	PTP general Message UDP Destination Port Number Setting Register	PGUDPR	32	32	9 to 211 PCLKA	2 to 106 ICLK	EPTPC a
000C 4940h	EPTPC 0	Frame Reception Filter Setting Register	FFLTR	32	32	9 to 211 PCLKA	2 to 106 ICLK	EPTPC a
000C 4960h	EPTPC 0	Frame Reception Filter MAC Address 0 Setting Registers	FMAC0RU	32	32	9 to 211 PCLKA	2 to 106 ICLK	EPTPC a
000C 4964h	EPTPC 0	Frame Reception Filter MAC Address 0 Setting Registers	FMAC0RL	32	32	9 to 211 PCLKA	2 to 106 ICLK	EPTPC a
000C 4968h	EPTPC 0	Frame Reception Filter MAC Address 1 Setting Registers	FMAC1RU	32	32	9 to 211 PCLKA	2 to 106 ICLK	EPTPC a
000C 496Ch	EPTPC 0	Frame Reception Filter MAC Address 1 Setting Registers	FMAC1RL	32	32	9 to 211 PCLKA	2 to 106 ICLK	EPTPC a
000C 49C0h	EPTPC 0	Asymmetric Delay Setting Register	DASYMRU	32	32	9 to 211 PCLKA	2 to 106 ICLK	EPTPC a
000C 49C4h	EPTPC 0	Asymmetric Delay Setting Register	DASYMRL	32	32	9 to 211 PCLKA	2 to 106 ICLK	EPTPC a
000C 49C8h	EPTPC 0	Timestamp Latency Setting Register	TSLATR	32	32	9 to 211 PCLKA	2 to 106 ICLK	EPTPC a
000C 49CCh	EPTPC 0	SYNFP Operation Setting Register	SYCONFR	32	32	9 to 211 PCLKA	2 to 106 ICLK	EPTPC a
000C 49D0h	EPTPC 0	SYNFP Frame Format Setting Register	SYFORMR	32	32	9 to 211 PCLKA	2 to 106 ICLK	EPTPC a
000C 49D4h	EPTPC 0	Response Message Reception Timeout Register	RSTOUTR	32	32	9 to 211 PCLKA	2 to 106 ICLK	EPTPC a
000C 4C00h	EPTPC 1	SYNFP Status Register	SYSR	32	32	9 to 211 PCLKA	2 to 106 ICLK	EPTPC a
000C 4C04h	EPTPC 1	SYNFP Status Notification Permission Register	SYIPR	32	32	9 to 211 PCLKA	2 to 106 ICLK	EPTPC a
000C 4C10h	EPTPC 1	SYNFP MAC Address Registers	SYMACRU	32	32	9 to 211 PCLKA	2 to 106 ICLK	EPTPC a
000C 4C14h	EPTPC 1	SYNFP MAC Address Registers	SYMACRL	32	32	9 to 211 PCLKA	2 to 106 ICLK	EPTPC a
000C 4C18h	EPTPC 1	SYNFP LLC-CTL Value Register	SYLLCCTLR	32	32	9 to 211 PCLKA	2 to 106 ICLK	EPTPC a
000C 4C1Ch	EPTPC 1	SYNFP Local IP Address Register	SYIPADDRR	32	32	9 to 211 PCLKA	2 to 106 ICLK	EPTPC a
000C 4C40h	EPTPC 1	SYNFP Specification Version Setting Register	SYSVRR	32	32	9 to 211 PCLKA	2 to 106 ICLK	EPTPC a

Table 4.1 List of I/O Registers (Address Order) (61 / 70)

Address	Module Symbol	Register Name	Register Symbol	Number of Bits	Access Size	Number of Access Cycles		Related Function
						ICLK ≥ PCLK	ICLK < PCLK	
000C 4C44h	EPTPC 1	SYNFP Domain Number Setting Register	SYDOMR	32	32	9 to 211 PCLKA	2 to 106 ICLK	EPTPC a
000C 4C50h	EPTPC 1	Announce Message Flag Field Setting Register	ANFR	32	32	9 to 211 PCLKA	2 to 106 ICLK	EPTPC a
000C 4C54h	EPTPC 1	Sync Message Flag Field Setting Register	SYNFR	32	32	9 to 211 PCLKA	2 to 106 ICLK	EPTPC a
000C 4C58h	EPTPC 1	Delay_Req Message Flag Field Setting Register	DYRQFR	32	32	9 to 211 PCLKA	2 to 106 ICLK	EPTPC a
000C 4C5Ch	EPTPC 1	Delay_Resp Message Flag Field Setting Register	DYRPPFR	32	32	9 to 211 PCLKA	2 to 106 ICLK	EPTPC a
000C 4C60h	EPTPC 1	SYNFP Local Clock ID Registers	SYCIDRU	32	32	9 to 211 PCLKA	2 to 106 ICLK	EPTPC a
000C 4C64h	EPTPC 1	SYNFP Local Clock ID Registers	SYCIDRL	32	32	9 to 211 PCLKA	2 to 106 ICLK	EPTPC a
000C 4C68h	EPTPC 1	SYNFP Local Port Number Register	SYPNUMR	32	32	9 to 211 PCLKA	2 to 106 ICLK	EPTPC a
000C 4C80h	EPTPC 1	SYNFP Register Value Load Directive Register	SYRVLDR	32	32	9 to 211 PCLKA	2 to 106 ICLK	EPTPC a
000C 4C90h	EPTPC 1	SYNFP Reception Filter Register 1	SYRFL1R	32	32	9 to 211 PCLKA	2 to 106 ICLK	EPTPC a
000C 4C94h	EPTPC 1	SYNFP Reception Filter Register 2	SYRFL2R	32	32	9 to 211 PCLKA	2 to 106 ICLK	EPTPC a
000C 4C98h	EPTPC 1	SYNFP Transmission Enable Register	SYTRENR	32	32	9 to 211 PCLKA	2 to 106 ICLK	EPTPC a
000C 4CA0h	EPTPC 1	Master Clock ID Register	MTCIDU	32	32	9 to 211 PCLKA	2 to 106 ICLK	EPTPC a
000C 4CA4h	EPTPC 1	Master Clock ID Register	MTCIDL	32	32	9 to 211 PCLKA	2 to 106 ICLK	EPTPC a
000C 4CA8h	EPTPC 1	Master Clock Port Number Register	MTPID	32	32	9 to 211 PCLKA	2 to 106 ICLK	EPTPC a
000C 4CC0h	EPTPC 1	SYNFP Transmission Interval Setting Register	SYTLIR	32	32	9 to 211 PCLKA	2 to 106 ICLK	EPTPC a
000C 4CC4h	EPTPC 1	SYNFP Received logMessageInterval Value Indication Register	SYRLIR	32	32	9 to 211 PCLKA	2 to 106 ICLK	EPTPC a
000C 4CC8h	EPTPC 1	offsetFromMaster Value Register	OFMRU	32	32	9 to 211 PCLKA	2 to 106 ICLK	EPTPC a
000C 4CCCh	EPTPC 1	offsetFromMaster Value Register	OFMRL	32	32	9 to 211 PCLKA	2 to 106 ICLK	EPTPC a
000C 4CD0h	EPTPC 1	meanPathDelay Value Register	MPDRU	32	32	9 to 211 PCLKA	2 to 106 ICLK	EPTPC a
000C 4CD4h	EPTPC 1	meanPathDelay Value Register	MPDRL	32	32	9 to 211 PCLKA	2 to 106 ICLK	EPTPC a
000C 4CE0h	EPTPC 1	grandmasterPriority Field Setting Register	GMPR	32	32	9 to 211 PCLKA	2 to 106 ICLK	EPTPC a
000C 4CE4h	EPTPC 1	grandmasterClockQuality Field Setting Register	GMCQR	32	32	9 to 211 PCLKA	2 to 106 ICLK	EPTPC a
000C 4CE8h	EPTPC 1	grandmasterIdentity Field Setting Registers	GMIDRU	32	32	9 to 211 PCLKA	2 to 106 ICLK	EPTPC a
000C 4CECh	EPTPC 1	grandmasterIdentity Field Setting Registers	GMIDRL	32	32	9 to 211 PCLKA	2 to 106 ICLK	EPTPC a
000C 4CF0h	EPTPC 1	currentUtcOffset/timeSource Field Setting Register	CUOTSR	32	32	9 to 211 PCLKA	2 to 106 ICLK	EPTPC a
000C 4CF4h	EPTPC 1	stepsRemoved Field Setting Register	SRR	32	32	9 to 211 PCLKA	2 to 106 ICLK	EPTPC a
000C 4D00h	EPTPC 1	PTP-primary Message Destination MAC Address Setting Registers	PPMACRU	32	32	9 to 211 PCLKA	2 to 106 ICLK	EPTPC a
000C 4D04h	EPTPC 1	PTP-primary Message Destination MAC Address Setting Registers	PPMACRL	32	32	9 to 211 PCLKA	2 to 106 ICLK	EPTPC a
000C 4D08h	EPTPC 1	PTP-pdelay Message MAC Address Setting Registers	PDMACRU	32	32	9 to 211 PCLKA	2 to 106 ICLK	EPTPC a
000C 4D0Ch	EPTPC 1	PTP-pdelay Message MAC Address Setting Registers	PDMACRL	32	32	9 to 211 PCLKA	2 to 106 ICLK	EPTPC a

Table 4.1 List of I/O Registers (Address Order) (62 / 70)

Address	Module Symbol	Register Name	Register Symbol	Number of Bits	Access Size	Number of Access Cycles		Related Function
						ICLK ≥ PCLK	ICLK < PCLK	
000C 4D10h	EPTPC 1	PTP Message EtherType Setting Register	PETYPER	32	32	9 to 211 PCLKA	2 to 106 ICLK	EPTPC a
000C 4D20h	EPTPC 1	PTP-primary Message Destination IP Address Setting Register	PPIPR	32	32	9 to 211 PCLKA	2 to 106 ICLK	EPTPC a
000C 4D24h	EPTPC 1	PTP-pdelay Message Destination IP Address Setting Register	PDIPR	32	32	9 to 211 PCLKA	2 to 106 ICLK	EPTPC a
000C 4D28h	EPTPC 1	PTP event Message TOS Setting Register	PETOSR	32	32	9 to 211 PCLKA	2 to 106 ICLK	EPTPC a
000C 4D2Ch	EPTPC 1	PTP general Message TOS Setting Register	PGTOSR	32	32	9 to 211 PCLKA	2 to 106 ICLK	EPTPC a
000C 4D30h	EPTPC 1	PTP-primary Message TTL Setting Register	PPTTLR	32	32	9 to 211 PCLKA	2 to 106 ICLK	EPTPC a
000C 4D34h	EPTPC 1	PTP-pdelay Message TTL Setting Register	PDTTLR	32	32	9 to 211 PCLKA	2 to 106 ICLK	EPTPC a
000C 4D38h	EPTPC 1	PTP event Message UDP Destination Port Number Setting Register	PEUDPR	32	32	9 to 211 PCLKA	2 to 106 ICLK	EPTPC a
000C 4D3Ch	EPTPC 1	PTP general Message UDP Destination Port Number Setting Register	PGUDPR	32	32	9 to 211 PCLKA	2 to 106 ICLK	EPTPC a
000C 4D40h	EPTPC 1	Frame Reception Filter Setting Register	FFLTR	32	32	9 to 211 PCLKA	2 to 106 ICLK	EPTPC a
000C 4D60h	EPTPC 1	Frame Reception Filter MAC Address 0 Setting Registers	FMAC0RU	32	32	9 to 211 PCLKA	2 to 106 ICLK	EPTPC a
000C 4D64h	EPTPC 1	Frame Reception Filter MAC Address 0 Setting Registers	FMAC0RL	32	32	9 to 211 PCLKA	2 to 106 ICLK	EPTPC a
000C 4D68h	EPTPC 1	Frame Reception Filter MAC Address 1 Setting Registers	FMAC1RU	32	32	9 to 211 PCLKA	2 to 106 ICLK	EPTPC a
000C 4D6Ch	EPTPC 1	Frame Reception Filter MAC Address 1 Setting Registers	FMAC1RL	32	32	9 to 211 PCLKA	2 to 106 ICLK	EPTPC a
000C 4DC0h	EPTPC 1	Asymmetric Delay Setting Register	DASYMRU	32	32	9 to 211 PCLKA	2 to 106 ICLK	EPTPC a
000C 4DC4h	EPTPC 1	Asymmetric Delay Setting Register	DASYMRL	32	32	9 to 211 PCLKA	2 to 106 ICLK	EPTPC a
000C 4DC8h	EPTPC 1	Timestamp Latency Setting Register	TSLATR	32	32	9 to 211 PCLKA	2 to 106 ICLK	EPTPC a
000C 4DCCh	EPTPC 1	SYNFP Operation Setting Register	SYCONFR	32	32	9 to 211 PCLKA	2 to 106 ICLK	EPTPC a
000C 4DD0h	EPTPC 1	SYNFP Frame Format Setting Register	SYFORMR	32	32	9 to 211 PCLKA	2 to 106 ICLK	EPTPC a
000C 4DD4h	EPTPC 1	Response Message Reception Timeout Register	RSTOUTR	32	32	9 to 211 PCLKA	2 to 106 ICLK	EPTPC a
000D 0000h	SCIFA8	Serial Mode Register	SMR	16	16	3, 4 PCLKB	2 ICLK	SCIFA
000D 0002h	SCIFA8	Bit Rate Register	BRR	8	8	3, 4 PCLKB	2 ICLK	SCIFA
000D 0002h	SCIFA8	Modulation Duty Register	MDDR	8	8	3, 4 PCLKB	2 ICLK	SCIFA
000D 0004h	SCIFA8	Serial Control Register	SCR	16	16	3, 4 PCLKB	2 ICLK	SCIFA
000D 0006h	SCIFA8	Transmit FIFO Data Register	FTDR	8	8	3, 4 PCLKB	2 ICLK	SCIFA
000D 0008h	SCIFA8	Serial Status Register	FSR	16	16	3, 4 PCLKB	2 ICLK	SCIFA
000D 000Ah	SCIFA8	Receive FIFO Data Register	FRDR	8	8	3, 4 PCLKB	2 ICLK	SCIFA
000D 000Ch	SCIFA8	FIFO Control Register	FCR	16	16	3, 4 PCLKB	2 ICLK	SCIFA
000D 000Eh	SCIFA8	FIFO Data Count Register	FDR	16	16	3, 4 PCLKB	2 ICLK	SCIFA
000D 0010h	SCIFA8	Serial Port Register	SPTR	16	16	3, 4 PCLKB	2 ICLK	SCIFA
000D 0012h	SCIFA8	Line Status Register	LSR	16	16	3, 4 PCLKB	2 ICLK	SCIFA
000D 0014h	SCIFA8	Serial Extended Mode Register	SEMR	8	8	3, 4 PCLKB	2 ICLK	SCIFA
000D 0016h	SCIFA8	FIFO Trigger Control Register	FTCR	16	16	3, 4 PCLKB	2 ICLK	SCIFA
000D 0020h	SCIFA9	Serial Mode Register	SMR	16	16	3, 4 PCLKB	2 ICLK	SCIFA
000D 0022h	SCIFA9	Bit Rate Register	BRR	8	8	3, 4 PCLKB	2 ICLK	SCIFA
000D 0022h	SCIFA9	Modulation Duty Register	MDDR	8	8	3, 4 PCLKB	2 ICLK	SCIFA
000D 0024h	SCIFA9	Serial Control Register	SCR	16	16	3, 4 PCLKB	2 ICLK	SCIFA
000D 0026h	SCIFA9	Transmit FIFO Data Register	FTDR	8	8	3, 4 PCLKB	2 ICLK	SCIFA

Table 4.1 List of I/O Registers (Address Order) (63 / 70)

Address	Module Symbol	Register Name	Register Symbol	Number of Bits	Access Size	Number of Access Cycles		Related Function
						ICLK ≥ PCLK	ICLK < PCLK	
000D 0028h	SCIFA9	Serial Status Register	FSR	16	16	3, 4 PCLKB	2 ICLK	SCIFA
000D 002Ah	SCIFA9	Receive FIFO Data Register	FRDR	8	8	3, 4 PCLKB	2 ICLK	SCIFA
000D 002Ch	SCIFA9	FIFO Control Register	FCR	16	16	3, 4 PCLKB	2 ICLK	SCIFA
000D 002Eh	SCIFA9	FIFO Data Count Register	FDR	16	16	3, 4 PCLKB	2 ICLK	SCIFA
000D 0030h	SCIFA9	Serial Port Register	SPTR	16	16	3, 4 PCLKB	2 ICLK	SCIFA
000D 0032h	SCIFA9	Line Status Register	LSR	16	16	3, 4 PCLKB	2 ICLK	SCIFA
000D 0034h	SCIFA9	Serial Extended Mode Register	SEMR	8	8	3, 4 PCLKB	2 ICLK	SCIFA
000D 0036h	SCIFA9	FIFO Trigger Control Register	FTCR	16	16	3, 4 PCLKB	2 ICLK	SCIFA
000D 0040h	SCIFA10	Serial Mode Register	SMR	16	16	3, 4 PCLKB	2 ICLK	SCIFA
000D 0042h	SCIFA10	Bit Rate Register	BRR	8	8	3, 4 PCLKB	2 ICLK	SCIFA
000D 0042h	SCIFA10	Modulation Duty Register	MDDR	8	8	3, 4 PCLKB	2 ICLK	SCIFA
000D 0044h	SCIFA10	Serial Control Register	SCR	16	16	3, 4 PCLKB	2 ICLK	SCIFA
000D 0046h	SCIFA10	Transmit FIFO Data Register	FTDR	8	8	3, 4 PCLKB	2 ICLK	SCIFA
000D 0048h	SCIFA10	Serial Status Register	FSR	16	16	3, 4 PCLKB	2 ICLK	SCIFA
000D 004Ah	SCIFA10	Receive FIFO Data Register	FRDR	8	8	3, 4 PCLKB	2 ICLK	SCIFA
000D 004Ch	SCIFA10	FIFO Control Register	FCR	16	16	3, 4 PCLKB	2 ICLK	SCIFA
000D 004Eh	SCIFA10	FIFO Data Count Register	FDR	16	16	3, 4 PCLKB	2 ICLK	SCIFA
000D 0050h	SCIFA10	Serial Port Register	SPTR	16	16	3, 4 PCLKB	2 ICLK	SCIFA
000D 0052h	SCIFA10	Line Status Register	LSR	16	16	3, 4 PCLKB	2 ICLK	SCIFA
000D 0054h	SCIFA10	Serial Extended Mode Register	SEMR	8	8	3, 4 PCLKB	2 ICLK	SCIFA
000D 0056h	SCIFA10	FIFO Trigger Control Register	FTCR	16	16	3, 4 PCLKB	2 ICLK	SCIFA
000D 0060h	SCIFA11	Serial Mode Register	SMR	16	16	3, 4 PCLKB	2 ICLK	SCIFA
000D 0062h	SCIFA11	Bit Rate Register	BRR	8	8	3, 4 PCLKB	2 ICLK	SCIFA
000D 0062h	SCIFA11	Modulation Duty Register	MDDR	8	8	3, 4 PCLKB	2 ICLK	SCIFA
000D 0064h	SCIFA11	Serial Control Register	SCR	16	16	3, 4 PCLKB	2 ICLK	SCIFA
000D 0066h	SCIFA11	Transmit FIFO Data Register	FTDR	8	8	3, 4 PCLKB	2 ICLK	SCIFA
000D 0068h	SCIFA11	Serial Status Register	FSR	16	16	3, 4 PCLKB	2 ICLK	SCIFA
000D 006Ah	SCIFA11	Receive FIFO Data Register	FRDR	8	8	3, 4 PCLKB	2 ICLK	SCIFA
000D 006Ch	SCIFA11	FIFO Control Register	FCR	16	16	3, 4 PCLKB	2 ICLK	SCIFA
000D 006Eh	SCIFA11	FIFO Data Count Register	FDR	16	16	3, 4 PCLKB	2 ICLK	SCIFA
000D 0070h	SCIFA11	Serial Port Register	SPTR	16	16	3, 4 PCLKB	2 ICLK	SCIFA
000D 0072h	SCIFA11	Line Status Register	LSR	16	16	3, 4 PCLKB	2 ICLK	SCIFA
000D 0074h	SCIFA11	Serial Extended Mode Register	SEMR	8	8	3, 4 PCLKB	2 ICLK	SCIFA
000D 0076h	SCIFA11	FIFO Trigger Control Register	FTCR	16	16	3, 4 PCLKB	2 ICLK	SCIFA
000D 0100h	RSPI0	RSPI Control Register	SPCR	8	8	3, 4 PCLKA	2 ICLK	RSPIa

Table 4.1 List of I/O Registers (Address Order) (64 / 70)

Address	Module Symbol	Register Name	Register Symbol	Number of Bits	Access Size	Number of Access Cycles		Related Function
						ICLK ≥ PCLK	ICLK < PCLK	
000D 0101h	RSPI0	RSPI Slave Select Polarity Register	SSLP	8	8	3, 4 PCLKA	2 ICLK	RSPIa
000D 0102h	RSPI0	RSPI Pin Control Register	SPPCR	8	8	3, 4 PCLKA	2 ICLK	RSPIa
000D 0103h	RSPI0	RSPI Status Register	SPSR	8	8	3, 4 PCLKA	2 ICLK	RSPIa
000D 0104h	RSPI0	RSPI Data Register	SPDR	32	16, 32	3, 4 PCLKA	2 ICLK	RSPIa
000D 0108h	RSPI0	RSPI Sequence Control Register	SPSCR	8	8	3, 4 PCLKA	2 ICLK	RSPIa
000D 0109h	RSPI0	RSPI Sequence Status Register	SPSSR	8	8	3, 4 PCLKA	2 ICLK	RSPIa
000D 010Ah	RSPI0	RSPI Bit Rate Register	SPBR	8	8	3, 4 PCLKA	2 ICLK	RSPIa
000D 010Bh	RSPI0	RSPI Data Control Register	SPDCR	8	8	3, 4 PCLKA	2 ICLK	RSPIa
000D 010Ch	RSPI0	RSPI Clock Delay Register	SPCKD	8	8	3, 4 PCLKA	2 ICLK	RSPIa
000D 010Dh	RSPI0	RSPI Slave Select Negation Delay Register	SSLND	8	8	3, 4 PCLKA	2 ICLK	RSPIa
000D 010Eh	RSPI0	RSPI Next-Access Delay Register	SPND	8	8	3, 4 PCLKA	2 ICLK	RSPIa
000D 010Fh	RSPI0	RSPI Control Register 2	SPCR2	8	8	3, 4 PCLKA	2 ICLK	RSPIa
000D 0110h	RSPI0	RSPI Command Register 0	SPCMD0	16	16	3, 4 PCLKA	2 ICLK	RSPIa
000D 0112h	RSPI0	RSPI Command Register 1	SPCMD1	16	16	3, 4 PCLKA	2 ICLK	RSPIa
000D 0114h	RSPI0	RSPI Command Register 2	SPCMD2	16	16	3, 4 PCLKA	2 ICLK	RSPIa
000D 0116h	RSPI0	RSPI Command Register 3	SPCMD3	16	16	3, 4 PCLKA	2 ICLK	RSPIa
000D 0118h	RSPI0	RSPI Command Register 4	SPCMD4	16	16	3, 4 PCLKA	2 ICLK	RSPIa
000D 011Ah	RSPI0	RSPI Command Register 5	SPCMD5	16	16	3, 4 PCLKA	2 ICLK	RSPIa
000D 011Ch	RSPI0	RSPI Command Register 6	SPCMD6	16	16	3, 4 PCLKA	2 ICLK	RSPIa
000D 011Eh	RSPI0	RSPI Command Register 7	SPCMD7	16	16	3, 4 PCLKA	2 ICLK	RSPIa
000D 0120h	RSPI1	RSPI Control Register	SPCR	8	8	3, 4 PCLKA	2 ICLK	RSPIa
000D 0121h	RSPI1	RSPI Slave Select Polarity Register	SSLP	8	8	3, 4 PCLKA	2 ICLK	RSPIa
000D 0122h	RSPI1	RSPI Pin Control Register	SPPCR	8	8	3, 4 PCLKA	2 ICLK	RSPIa
000D 0123h	RSPI1	RSPI Status Register	SPSR	8	8	3, 4 PCLKA	2 ICLK	RSPIa
000D 0124h	RSPI1	RSPI Data Register	SPDR	32	32	3, 4 PCLKA	2 ICLK	RSPIa
000D 0128h	RSPI1	RSPI Sequence Control Register	SPSCR	8	8	3, 4 PCLKA	2 ICLK	RSPIa
000D 0129h	RSPI1	RSPI Sequence Status Register	SPSSR	8	8	3, 4 PCLKA	2 ICLK	RSPIa
000D 012Ah	RSPI1	RSPI Bit Rate Register	SPBR	8	8	3, 4 PCLKA	2 ICLK	RSPIa
000D 012Bh	RSPI1	RSPI Data Control Register	SPDCR	8	8	3, 4 PCLKA	2 ICLK	RSPIa
000D 012Ch	RSPI1	RSPI Clock Delay Register	SPCKD	8	8	3, 4 PCLKA	2 ICLK	RSPIa
000D 012Dh	RSPI1	RSPI Slave Select Negation Delay Register	SSLND	8	8	3, 4 PCLKA	2 ICLK	RSPIa
000D 012Eh	RSPI1	RSPI Next-Access Delay Register	SPND	8	8	3, 4 PCLKA	2 ICLK	RSPIa
000D 012Fh	RSPI1	RSPI Control Register 2	SPCR2	8	8	3, 4 PCLKA	2 ICLK	RSPIa
000D 0130h	RSPI1	RSPI Command Register 0	SPCMD0	16	16	3, 4 PCLKA	2 ICLK	RSPIa
000D 0132h	RSPI1	RSPI Command Register 1	SPCMD1	16	16	3, 4 PCLKA	2 ICLK	RSPIa
000D 0134h	RSPI1	RSPI Command Register 2	SPCMD2	16	16	3, 4 PCLKA	2 ICLK	RSPIa
000D 0136h	RSPI1	RSPI Command Register 3	SPCMD3	16	16	3, 4 PCLKA	2 ICLK	RSPIa
000D 0138h	RSPI1	RSPI Command Register 4	SPCMD4	16	16	3, 4 PCLKA	2 ICLK	RSPIa
000D 013Ah	RSPI1	RSPI Command Register 5	SPCMD5	16	16	3, 4 PCLKA	2 ICLK	RSPIa
000D 013Ch	RSPI1	RSPI Command Register 6	SPCMD6	16	16	3, 4 PCLKA	2 ICLK	RSPIa
000D 013Eh	RSPI1	RSPI Command Register 7	SPCMD7	16	16	3, 4 PCLKA	2 ICLK	RSPIa
000D 0400h	USBA	System Configuration Control Register	SYSCFG	16	16	3, 4 PCLKB	2 ICLK	USBAa
000D 0402h	USBA	CPU Bus Wait Register	BUSWAIT	16	16	3, 4 PCLKB	2 ICLK	USBAa
000D 0404h	USBA	System Configuration Status Register	SYSSTS0	16	16	(3 + BUSWAIT) PCLKA or more	Rounded up to the nearest integer greater than $1 + (3 + \text{BUSWAIT}) \times (\text{frequency ratio of ICLK/PCLKB})^{15}$	USBAa

Table 4.1 List of I/O Registers (Address Order) (65 / 70)

Address	Module Symbol	Register Name	Register Symbol	Number of Bits	Access Size	Number of Access Cycles		Related Function
						ICLK ≥ PCLK	ICLK < PCLK	
000D 0406h	USBA	PLL Status Register	PLLSTA	16	16	(3 + BUSWAIT) PCLKA or more	Rounded up to the nearest integer greater than $1 + (3 + \text{BUSWAIT}) \times (\text{frequency ratio of ICLK/PCLKB})^{*5}$	USBAa
000D 0408h	USBA	Device State Control Register 0	DVSTCTR0	16	16	(3 + BUSWAIT) PCLKA or more	Rounded up to the nearest integer greater than $1 + (3 + \text{BUSWAIT}) \times (\text{frequency ratio of ICLK/PCLKB})^{*5}$	USBAa
000D 0414h	USBA	CFIFO Port Register	CFIFO	32	8,16,32	(3 + BUSWAIT) PCLKA or more	Rounded up to the nearest integer greater than $1 + (3 + \text{BUSWAIT}) \times (\text{frequency ratio of ICLK/PCLKB})^{*5}$	USBAa
000D 0418h	USBA	D0FIFO Port Register	D0FIFO	32	8,16,32	(3 + BUSWAIT) PCLKA or more	Rounded up to the nearest integer greater than $1 + (3 + \text{BUSWAIT}) \times (\text{frequency ratio of ICLK/PCLKB})^{*5}$	USBAa
000D 041Ch	USBA	D1FIFO Port Register	D1FIFO	32	8,16,32	(3 + BUSWAIT) PCLKA or more	Rounded up to the nearest integer greater than $1 + (3 + \text{BUSWAIT}) \times (\text{frequency ratio of ICLK/PCLKB})^{*5}$	USBAa
000D 0420h	USBA	CFIFO Port Select Register	CFIFOSEL	16	16	(3 + BUSWAIT) PCLKA or more	Rounded up to the nearest integer greater than $1 + (3 + \text{BUSWAIT}) \times (\text{frequency ratio of ICLK/PCLKB})^{*5}$	USBAa
000D 0422h	USBA	CFIFO Port Control Register	CFIFOCTR	16	16	(3 + BUSWAIT) PCLKA or more	Rounded up to the nearest integer greater than $1 + (3 + \text{BUSWAIT}) \times (\text{frequency ratio of ICLK/PCLKB})^{*5}$	USBAa
000D 0428h	USBA	D0FIFO Port Select Register	D0FIFOSEL	16	16	(3 + BUSWAIT) PCLKA or more	Rounded up to the nearest integer greater than $1 + (3 + \text{BUSWAIT}) \times (\text{frequency ratio of ICLK/PCLKB})^{*5}$	USBAa
000D 042Ah	USBA	D0FIFO Port Control Register	D0FIFOCTR	16	16	(3 + BUSWAIT) PCLKA or more	Rounded up to the nearest integer greater than $1 + (3 + \text{BUSWAIT}) \times (\text{frequency ratio of ICLK/PCLKB})^{*5}$	USBAa
000D 042Ch	USBA	D1FIFO Port Select Register	D1FIFOSEL	16	16	(3 + BUSWAIT) PCLKA or more	Rounded up to the nearest integer greater than $1 + (3 + \text{BUSWAIT}) \times (\text{frequency ratio of ICLK/PCLKB})^{*5}$	USBAa
000D 042Eh	USBA	D1FIFO Port Control Register	D1FIFOCTR	16	16	(3 + BUSWAIT) PCLKA or more	Rounded up to the nearest integer greater than $1 + (3 + \text{BUSWAIT}) \times (\text{frequency ratio of ICLK/PCLKB})^{*5}$	USBAa
000D 0430h	USBA	Interrupt Enable Register 0	INTENB0	16	16	(3 + BUSWAIT) PCLKA or more	Rounded up to the nearest integer greater than $1 + (3 + \text{BUSWAIT}) \times (\text{frequency ratio of ICLK/PCLKB})^{*5}$	USBAa

Table 4.1 List of I/O Registers (Address Order) (66 / 70)

Address	Module Symbol	Register Name	Register Symbol	Number of Bits	Access Size	Number of Access Cycles		Related Function
						ICLK ≥ PCLK	ICLK < PCLK	
000D 0432h	USBA	Interrupt Enable Register 1	INTENB1	16	16	(3 + BUSWAIT) PCLKA or more	Rounded up to the nearest integer greater than $1 + (3 + \text{BUSWAIT}) \times (\text{frequency ratio of ICLK/PCLKB})^{*5}$	USBAa
000D 0436h	USBA	BRDY Interrupt Enable Register	BRDYENB	16	16	(3 + BUSWAIT) PCLKA or more	Rounded up to the nearest integer greater than $1 + (3 + \text{BUSWAIT}) \times (\text{frequency ratio of ICLK/PCLKB})^{*5}$	USBAa
000D 0438h	USBA	NRDY Interrupt Enable Register	NRDYENB	16	16	(3 + BUSWAIT) PCLKA or more	Rounded up to the nearest integer greater than $1 + (3 + \text{BUSWAIT}) \times (\text{frequency ratio of ICLK/PCLKB})^{*5}$	USBAa
000D 043Ah	USBA	BEMP Interrupt Enable Register	BEMPENB	16	16	(3 + BUSWAIT) PCLKA or more	Rounded up to the nearest integer greater than $1 + (3 + \text{BUSWAIT}) \times (\text{frequency ratio of ICLK/PCLKB})^{*5}$	USBAa
000D 043Ch	USBA	SOF Output Configuration Register	SOFCFG	16	16	(3 + BUSWAIT) PCLKA or more	Rounded up to the nearest integer greater than $1 + (3 + \text{BUSWAIT}) \times (\text{frequency ratio of ICLK/PCLKB})^{*5}$	USBAa
000D 043Eh	USBA	PHY Setting Register	PHYSET	16	16	(3 + BUSWAIT) PCLKA or more	Rounded up to the nearest integer greater than $1 + (3 + \text{BUSWAIT}) \times (\text{frequency ratio of ICLK/PCLKB})^{*5}$	USBAa
000D 0440h	USBA	Interrupt Status Register 0	INTSTS0	16	16	(3 + BUSWAIT) PCLKA or more	Rounded up to the nearest integer greater than $1 + (3 + \text{BUSWAIT}) \times (\text{frequency ratio of ICLK/PCLKB})^{*5}$	USBAa
000D 0442h	USBA	Interrupt Status Register 1	INTSTS1	16	16	(3 + BUSWAIT) PCLKA or more	Rounded up to the nearest integer greater than $1 + (3 + \text{BUSWAIT}) \times (\text{frequency ratio of ICLK/PCLKB})^{*5}$	USBAa
000D 0446h	USBA	BRDY Interrupt Status Register	BRDYSTS	16	16	(3 + BUSWAIT) PCLKA or more	Rounded up to the nearest integer greater than $1 + (3 + \text{BUSWAIT}) \times (\text{frequency ratio of ICLK/PCLKB})^{*5}$	USBAa
000D 0448h	USBA	NRDY Interrupt Status Register	NRDYSTS	16	16	(3 + BUSWAIT) PCLKA or more	Rounded up to the nearest integer greater than $1 + (3 + \text{BUSWAIT}) \times (\text{frequency ratio of ICLK/PCLKB})^{*5}$	USBAa
000D 044Ah	USBA	BEMP Interrupt Status Register	BEMPSTS	16	16	(3 + BUSWAIT) PCLKA or more	Rounded up to the nearest integer greater than $1 + (3 + \text{BUSWAIT}) \times (\text{frequency ratio of ICLK/PCLKB})^{*5}$	USBAa
000D 044Ch	USBA	Frame Number Register	FRMNUM	16	16	(3 + BUSWAIT) PCLKA or more	Rounded up to the nearest integer greater than $1 + (3 + \text{BUSWAIT}) \times (\text{frequency ratio of ICLK/PCLKB})^{*5}$	USBAa

Table 4.1 List of I/O Registers (Address Order) (67 / 70)

Address	Module Symbol	Register Name	Register Symbol	Number of Bits	Access Size	Number of Access Cycles		Related Function
						ICLK ≥ PCLK	ICLK < PCLK	
000D 044Eh	USBA	μFrame Number Register	UFRMNUM	16	16	(3 + BUSWAIT) PCLKA or more	Rounded up to the nearest integer greater than $1 + (3 + \text{BUSWAIT}) \times (\text{frequency ratio of ICLK/PCLKB})^{*5}$	USBAa
000D 0450h	USBA	USB Address Register	USBADDR	16	16	(3 + BUSWAIT) PCLKA or more	Rounded up to the nearest integer greater than $1 + (3 + \text{BUSWAIT}) \times (\text{frequency ratio of ICLK/PCLKB})^{*5}$	USBAa
000D 0454h	USBA	USB Request Type Register	USBREQ	16	16	(3 + BUSWAIT) PCLKA or more	Rounded up to the nearest integer greater than $1 + (3 + \text{BUSWAIT}) \times (\text{frequency ratio of ICLK/PCLKB})^{*5}$	USBAa
000D 0456h	USBA	USB Request Value Register	USBVAL	16	16	(3 + BUSWAIT) PCLKA or more	Rounded up to the nearest integer greater than $1 + (3 + \text{BUSWAIT}) \times (\text{frequency ratio of ICLK/PCLKB})^{*5}$	USBAa
000D 0458h	USBA	USB Request Index Register	USBINDX	16	16	(3 + BUSWAIT) PCLKA or more	Rounded up to the nearest integer greater than $1 + (3 + \text{BUSWAIT}) \times (\text{frequency ratio of ICLK/PCLKB})^{*5}$	USBAa
000D 045Ah	USBA	USB Request Length Register	USBLENG	16	16	(3 + BUSWAIT) PCLKA or more	Rounded up to the nearest integer greater than $1 + (3 + \text{BUSWAIT}) \times (\text{frequency ratio of ICLK/PCLKB})^{*5}$	USBAa
000D 045Ch	USBA	DCP Configuration Register	DCPCFG	16	16	(3 + BUSWAIT) PCLKA or more	Rounded up to the nearest integer greater than $1 + (3 + \text{BUSWAIT}) \times (\text{frequency ratio of ICLK/PCLKB})^{*5}$	USBAa
000D 045Eh	USBA	DCP Maximum Packet Size Register	DCPMAXP	16	16	(3 + BUSWAIT) PCLKA or more	Rounded up to the nearest integer greater than $1 + (3 + \text{BUSWAIT}) \times (\text{frequency ratio of ICLK/PCLKB})^{*5}$	USBAa
000D 0460h	USBA	DCP Control Register	DCPCTR	16	16	(3 + BUSWAIT) PCLKA or more	Rounded up to the nearest integer greater than $1 + (3 + \text{BUSWAIT}) \times (\text{frequency ratio of ICLK/PCLKB})^{*5}$	USBAa
000D 0464h	USBA	Pipe Window Select Register	PIPESEL	16	16	(3 + BUSWAIT) PCLKA or more	Rounded up to the nearest integer greater than $1 + (3 + \text{BUSWAIT}) \times (\text{frequency ratio of ICLK/PCLKB})^{*5}$	USBAa
000D 0468h	USBA	Pipe Configuration Register	PIPECFG	16	16	(3 + BUSWAIT) PCLKA or more	Rounded up to the nearest integer greater than $1 + (3 + \text{BUSWAIT}) \times (\text{frequency ratio of ICLK/PCLKB})^{*5}$	USBAa
000D 046Ah	USBA	Pipe Buffer Register	PIPEBUF	16	16	(3 + BUSWAIT) PCLKA or more	Rounded up to the nearest integer greater than $1 + (3 + \text{BUSWAIT}) \times (\text{frequency ratio of ICLK/PCLKB})^{*5}$	USBAa

Table 4.1 List of I/O Registers (Address Order) (68 / 70)

Address	Module Symbol	Register Name	Register Symbol	Number of Bits	Access Size	Number of Access Cycles		Related Function
						ICLK ≥ PCLK	ICLK < PCLK	
000D 046Ch	USBA	Pipe Maximum Packet Size Register	PIPEMAXP	16	16	(3 + BUSWAIT) PCLKA or more	Rounded up to the nearest integer greater than $1 + (3 + \text{BUSWAIT}) \times (\text{frequency ratio of ICLK/PCLKB})^{*5}$	USBAA
000D 046Eh	USBA	Pipe Cycle Control Register	PIPEPERI	16	16	(3 + BUSWAIT) PCLKA or more	Rounded up to the nearest integer greater than $1 + (3 + \text{BUSWAIT}) \times (\text{frequency ratio of ICLK/PCLKB})^{*5}$	USBAA
000D 0470h	USBA	Pipe1 Control Register	PIPE1CTR	16	16	(3 + BUSWAIT) PCLKA or more	Rounded up to the nearest integer greater than $1 + (3 + \text{BUSWAIT}) \times (\text{frequency ratio of ICLK/PCLKB})^{*5}$	USBAA
000D 0472h	USBA	Pipe2 Control Register	PIPE2CTR	16	16	(3 + BUSWAIT) PCLKA or more	Rounded up to the nearest integer greater than $1 + (3 + \text{BUSWAIT}) \times (\text{frequency ratio of ICLK/PCLKB})^{*5}$	USBAA
000D 0474h	USBA	Pipe3 Control Register	PIPE3CTR	16	16	(3 + BUSWAIT) PCLKA or more	Rounded up to the nearest integer greater than $1 + (3 + \text{BUSWAIT}) \times (\text{frequency ratio of ICLK/PCLKB})^{*5}$	USBAA
000D 0476h	USBA	Pipe4 Control Register	PIPE4CTR	16	16	(3 + BUSWAIT) PCLKA or more	Rounded up to the nearest integer greater than $1 + (3 + \text{BUSWAIT}) \times (\text{frequency ratio of ICLK/PCLKB})^{*5}$	USBAA
000D 0478h	USBA	Pipe5 Control Register	PIPE5CTR	16	16	(3 + BUSWAIT) PCLKA or more	Rounded up to the nearest integer greater than $1 + (3 + \text{BUSWAIT}) \times (\text{frequency ratio of ICLK/PCLKB})^{*5}$	USBAA
000D 047Ah	USBA	Pipe6 Control Register	PIPE6CTR	16	16	(3 + BUSWAIT) PCLKA or more	Rounded up to the nearest integer greater than $1 + (3 + \text{BUSWAIT}) \times (\text{frequency ratio of ICLK/PCLKB})^{*5}$	USBAA
000D 047Ch	USBA	Pipe7 Control Register	PIPE7CTR	16	16	(3 + BUSWAIT) PCLKA or more	Rounded up to the nearest integer greater than $1 + (3 + \text{BUSWAIT}) \times (\text{frequency ratio of ICLK/PCLKB})^{*5}$	USBAA
000D 047Eh	USBA	Pipe8 Control Register	PIPE8CTR	16	16	(3 + BUSWAIT) PCLKA or more	Rounded up to the nearest integer greater than $1 + (3 + \text{BUSWAIT}) \times (\text{frequency ratio of ICLK/PCLKB})^{*5}$	USBAA
000D 0480h	USBA	Pipe9 Control Register	PIPE9CTR	16	16	(3 + BUSWAIT) PCLKA or more	Rounded up to the nearest integer greater than $1 + (3 + \text{BUSWAIT}) \times (\text{frequency ratio of ICLK/PCLKB})^{*5}$	USBAA
000D 0490h	USBA	Pipe1 Transaction Counter Enable Register	PIPE1TRE	16	16	(3 + BUSWAIT) PCLKA or more	Rounded up to the nearest integer greater than $1 + (3 + \text{BUSWAIT}) \times (\text{frequency ratio of ICLK/PCLKB})^{*5}$	USBAA

Table 4.1 List of I/O Registers (Address Order) (69 / 70)

Address	Module Symbol	Register Name	Register Symbol	Number of Bits	Access Size	Number of Access Cycles		Related Function
						ICLK ≥ PCLK	ICLK < PCLK	
000D 0492h	USBA	Pipe1 Transaction Counter Register	PIPE1TRN	16	16	(3 + BUSWAIT) PCLKA or more	Rounded up to the nearest integer greater than 1 + (3 + BUSWAIT) × (frequency ratio of ICLK/ PCLKB) ^{*5}	USBAA
000D 0494h	USBA	Pipe2 Transaction Counter Enable Register	PIPE2TRE	16	16	(3 + BUSWAIT) PCLKA or more	Rounded up to the nearest integer greater than 1 + (3 + BUSWAIT) × (frequency ratio of ICLK/ PCLKB) ^{*5}	USBAA
000D 0496h	USBA	Pipe2 Transaction Counter Register	PIPE2TRN	16	16	(3 + BUSWAIT) PCLKA or more	Rounded up to the nearest integer greater than 1 + (3 + BUSWAIT) × (frequency ratio of ICLK/ PCLKB) ^{*5}	USBAA
000D 0498h	USBA	Pipe3 Transaction Counter Enable Register	PIPE3TRE	16	16	(3 + BUSWAIT) PCLKA or more	Rounded up to the nearest integer greater than 1 + (3 + BUSWAIT) × (frequency ratio of ICLK/ PCLKB) ^{*5}	USBAA
000D 049Ah	USBA	Pipe3 Transaction Counter Register	PIPE3TRN	16	16	(3 + BUSWAIT) PCLKA or more	Rounded up to the nearest integer greater than 1 + (3 + BUSWAIT) × (frequency ratio of ICLK/ PCLKB) ^{*5}	USBAA
000D 049Ch	USBA	Pipe4 Transaction Counter Enable Register	PIPE4TRE	16	16	(3 + BUSWAIT) PCLKA or more	Rounded up to the nearest integer greater than 1 + (3 + BUSWAIT) × (frequency ratio of ICLK/ PCLKB) ^{*5}	USBAA
000D 049Eh	USBA	Pipe4 Transaction Counter Register	PIPE4TRN	16	16	(3 + BUSWAIT) PCLKA or more	Rounded up to the nearest integer greater than 1 + (3 + BUSWAIT) × (frequency ratio of ICLK/ PCLKB) ^{*5}	USBAA
000D 04A0h	USBA	Pipe5 Transaction Counter Enable Register	PIPE5TRE	16	16	(3 + BUSWAIT) PCLKA or more	Rounded up to the nearest integer greater than 1 + (3 + BUSWAIT) × (frequency ratio of ICLK/ PCLKB) ^{*5}	USBAA
000D 04A2h	USBA	Pipe5 Transaction Counter Register	PIPE5TRN	16	16	(3 + BUSWAIT) PCLKA or more	Rounded up to the nearest integer greater than 1 + (3 + BUSWAIT) × (frequency ratio of ICLK/ PCLKB) ^{*5}	USBAA
000D 04D0h	USBA	Device Address 0 Configuration Register	DEVADD0	16	16	(3 + BUSWAIT) PCLKA or more	Rounded up to the nearest integer greater than 1 + (3 + BUSWAIT) × (frequency ratio of ICLK/ PCLKB) ^{*5}	USBAA
000D 04D2h	USBA	Device Address 1 Configuration Register	DEVADD1	16	16	(3 + BUSWAIT) PCLKA or more	Rounded up to the nearest integer greater than 1 + (3 + BUSWAIT) × (frequency ratio of ICLK/ PCLKB) ^{*5}	USBAA
000D 04D4h	USBA	Device Address 2 Configuration Register	DEVADD2	16	16	(3 + BUSWAIT) PCLKA or more	Rounded up to the nearest integer greater than 1 + (3 + BUSWAIT) × (frequency ratio of ICLK/ PCLKB) ^{*5}	USBAA

Table 4.1 List of I/O Registers (Address Order) (70 / 70)

Address	Module Symbol	Register Name	Register Symbol	Number of Bits	Access Size	Number of Access Cycles		Related Function
						ICLK ≥ PCLK	ICLK < PCLK	
000D 04D6h	USBA	Device Address 3 Configuration Register	DEVADD3	16	16	(3 + BUSWAIT) PCLKA or more	Rounded up to the nearest integer greater than $1 + (3 + \text{BUSWAIT}) \times (\text{frequency ratio of ICLK/PCLKB})^{*5}$	USBAa
000D 04D8h	USBA	Device Address 4 Configuration Register	DEVADD4	16	16	(3 + BUSWAIT) PCLKA or more	Rounded up to the nearest integer greater than $1 + (3 + \text{BUSWAIT}) \times (\text{frequency ratio of ICLK/PCLKB})^{*5}$	USBAa
000D 04DAh	USBA	Device Address 5 Configuration Register	DEVADD5	16	16	(3 + BUSWAIT) PCLKA or more	Rounded up to the nearest integer greater than $1 + (3 + \text{BUSWAIT}) \times (\text{frequency ratio of ICLK/PCLKB})^{*5}$	USBAa
000D 0500h	USBA	Low Power Control Register	LPCTRL	16	16	(3 + BUSWAIT) PCLKA or more	Rounded up to the nearest integer greater than $1 + (3 + \text{BUSWAIT}) \times (\text{frequency ratio of ICLK/PCLKB})^{*5}$	USBAa
000D 0502h	USBA	Low Power Status Register	LPSTS	16	16	(3 + BUSWAIT) PCLKA or more	Rounded up to the nearest integer greater than $1 + (3 + \text{BUSWAIT}) \times (\text{frequency ratio of ICLK/PCLKB})^{*5}$	USBAa
000D 0540h	USBA	Battery Charging Control Register	BCCTRL	16	16	(3 + BUSWAIT) PCLKA or more	Rounded up to the nearest integer greater than $1 + (3 + \text{BUSWAIT}) \times (\text{frequency ratio of ICLK/PCLKB})^{*5}$	USBAa
000D 0544h	USBA	Function L1 Control Register 1	PL1CTRL1	16	16	(3 + BUSWAIT) PCLKA or more	Rounded up to the nearest integer greater than $1 + (3 + \text{BUSWAIT}) \times (\text{frequency ratio of ICLK/PCLKB})^{*5}$	USBAa
000D 0546h	USBA	Function L1 Control Register 2	PL1CTRL2	16	16	(3 + BUSWAIT) PCLKA or more	Rounded up to the nearest integer greater than $1 + (3 + \text{BUSWAIT}) \times (\text{frequency ratio of ICLK/PCLKB})^{*5}$	USBAa
000D 0548h	USBA	Host L1 Control Register 1	HL1CTRL1	16	16	(3 + BUSWAIT) PCLKA or more	Rounded up to the nearest integer greater than $1 + (3 + \text{BUSWAIT}) \times (\text{frequency ratio of ICLK/PCLKB})^{*5}$	USBAa
000D 054Ah	USBA	Host L1 Control Register 2	HL1CTRL2	16	16	(3 + BUSWAIT) PCLKA or more	Rounded up to the nearest integer greater than $1 + (3 + \text{BUSWAIT}) \times (\text{frequency ratio of ICLK/PCLKB})^{*5}$	USBAa
000D 0560h	USBA	Deep Standby USB Transceiver Control/Pin Monitor Register	DPUSR0R	32	32	(3 + BUSWAIT) PCLKA or more	Rounded up to the nearest integer greater than $1 + (3 + \text{BUSWAIT}) \times (\text{frequency ratio of ICLK/PCLKB})^{*5}$	USBAa
000D 0564h	USBA	Deep Standby USB Suspend/Resume Interrupt Register	DPUSR1R	32	32	(3 + BUSWAIT) PCLKA or more	Rounded up to the nearest integer greater than $1 + (3 + \text{BUSWAIT}) \times (\text{frequency ratio of ICLK/PCLKB})^{*5}$	USBAa

- Note 1. When the same output trigger is specified for pulse output groups 2 and 3 by the PPG0.PCR setting, the PPG0.NDRH address is 0008 81ECh. When different output triggers are specified, the PPG0.NDRH addresses for pulse output groups 2 and 3 are 0008 81EEh and 0008 81ECh, respectively.
- Note 2. When the same output trigger is specified for pulse output groups 0 and 1 by the PPG0.PCR setting, the PPG0.NDRL address is 0008 81EDh. When different output triggers are specified, the PPG0.NDRL addresses for pulse output groups 0 and 1 are 0008 81EFh and 0008 81EDh, respectively.
- Note 3. When the same output trigger is specified for pulse output groups 6 and 7 by the PPG1.PCR setting, the PPG1.NDRH address is 0008 81FCh. When different output triggers are specified, the PPG1.NDRH addresses for pulse output groups 6 and 7 are 0008 81FEh and 0008 81FCh, respectively.
- Note 4. When the same output trigger is specified for pulse output groups 4 and 5 by the PPG1.PCR setting, the PPG1.NDRL address is 0008 81FDh. When different output triggers are specified, the PPG1.NDRL addresses for pulse output groups 4 and 5 are 0008 81FFh and 0008 81FDh, respectively.
- Note 5. When the register is accessed while the USB is operating, a delay may be generated in accessing.
- Note 6. The address must end with 0h, 4h, 8h, or Ch when access is made in 32-bit units. The address must end with 0h, 2h, 4h, 6h, 8h, Ah, Ch, or Eh when access is made in 16-bit units.

5. Electrical Characteristics

5.1 Absolute Maximum Ratings

Table 5.1 Absolute Maximum Rating

Conditions: VSS = AVSS0 = AVSS1 = VREFL0 = VSS_USB = VSS1_USBA = VSS2_USBA = PVSS_USBA = AVSS_USBA = 0 V

Item	Symbol	Value	Unit
Power supply voltage	VCC, VCC_USB	-0.3 to +4.6	V
V _{BATT} power supply voltage	V _{BATT}	-0.3 to +4.6	V
Input voltage (except for ports for 5 V tolerant*1)	V _{in}	-0.3 to VCC + 0.3	V
Input voltage (ports for 5 V tolerant*1)	V _{in}	-0.3 to VCC + 4.6 (≤ 5.8 max.)	V
Reference power supply voltage	VREFH0	-0.3 to AVCC0 + 0.3	V
Analog power supply voltage	AVCC0, AVCC1*2	-0.3 to +4.6	V
USBA power supply voltage	VCC_USBA*2	-0.3 to +4.6	V
USBA analog power supply voltage	AVCC_USBA*2	-0.3 to +4.6	V
Analog input voltage	V _{AN}	-0.3 to AVCC + 0.3	V
Junction temperature	D version	T _j	°C
	G version		
Storage temperature	T _{stg}	-55 to +125	°C

Caution: Permanent damage to the LSI may result if absolute maximum ratings are exceeded.

Note 1. Ports 07, 11 to 17, 20, 21, 30 to 33, 67, and C0 to C3 are 5 V tolerant.

Note 2. Connect the AVCC0, AVCC1, and VCC_USB pins to VCC, and the AVSS0, AVSS1, and VSS_USB pins to VSS.

When the A/D converter unit 0 is not to be used, connect the VREFH0 pin to VCC and the VREFL0 pin to VSS, respectively. Do not leave these pins open.

When the USBA is not to be used, connect the VCC_USBA and AVCC_USBA pins to VCC and the VSS1_USBA, VSS2_USBA, PVSS_USBA, and AVSS_USBA pins to VSS, respectively. Do not leave these pins open.

Table 5.2 Recommended Operating Conditions

Item	Symbol	Min.	Typ.	Max.	Unit	
Power supply voltage	VCC	2.7	—	3.6	V	
	VSS	—	0	—	V	
V _{BATT} power supply voltage	V _{BATT}	2.0	—	3.6	V	
Reference power voltage	VREFH0	2.7	—	AVCC0	V	
	VREFL0	—	0	—	V	
Analog power supply voltage	AVCC0, AVCC1	—	VCC	—	V	
	AVSS0, AVSS1	—	0	—	V	
USB power supply voltage	VCC_USB	—	VCC	—	V	
	VSS_USB	—	0	—	V	
USBA power supply voltage	VCC_USBA	3.0	—	3.6	V	
	VSS1_USBA, VSS2_USBA	—	0	—	V	
USBA analog power supply voltage	AVCC_USBA	3.0	—	3.6	V	
	AVSS_USBA, PVSS_USBA	—	0	—	V	
Operating temperature	D version	T _{opr}	-40	—	85	°C
	G version	T _{opr}	-40	—	105 (under planning)	°C

5.2 DC Characteristics

Table 5.3 DC Characteristics (1)

Conditions: $V_{CC} = AV_{CC0} = AV_{CC1} = V_{CC_USB} = V_{BATT} = 2.7$ to 3.6 V, $2.7 \leq V_{REFH0} \leq AV_{CC0}$,
 $V_{CC_USBA} = AV_{CC_USBA} = 3.0$ to 3.6 V,
 $V_{SS} = AV_{SS0} = AV_{SS1} = V_{REFL0} = V_{SS_USB} = V_{SS1_USBA} = V_{SS2_USBA} = PV_{SS_USBA} = AV_{SS_USBA} = 0$ V,
 $T_a = T_{opr}$

Item		Symbol	Min.	Typ.	Max.	Unit	Test Conditions
Schmitt trigger input voltage	IRQ input pin*1	V_{IH}	$V_{CC} \times 0.8$	—	$V_{CC} + 0.3$	V	
	MTU input pin*1	V_{IL}	-0.3	—	$V_{CC} \times 0.2$		
	GPT input pin*1	ΔV_T	$V_{CC} \times 0.06$	—	—		
	POE3 input pin*1						
	TPU input pin*1						
	TMR input pin*1						
	CMTW input pin*1						
	RTC input pin*1						
	SCI input pin*1						
	ADTRG# input pin*1						
	QSPI input pin*1						
	RES#, NMI, TCK						
RIIC input pin (except for SMBus)	V_{IH}	$V_{CC} \times 0.7$	—	$V_{CC} + 3.6$ (≤ 5.8 max.)			
	V_{IL}	-0.3	—	$V_{CC} \times 0.3$			
	ΔV_T	$V_{CC} \times 0.05$	—	—			
Ports for 5 V tolerant*2	V_{IH}	$V_{CC} \times 0.8$	—	$V_{CC} + 3.6$ (≤ 5.8 max.)			
	V_{IL}	-0.3	—	$V_{CC} \times 0.2$			
Other input pins excluding ports for 5 V tolerant*3	V_{IH}	$V_{CC} \times 0.8$	—	$V_{CC} + 0.3$			
	V_{IL}	-0.3	—	$V_{CC} \times 0.2$			
Input high voltage (except for Schmitt trigger input pin)	MD pin, EMLE	V_{IH}	$V_{CC} \times 0.9$	—	$V_{CC} + 0.3$	V	
	EXTAL, RSPI input pin, EXDMAC input pin, WAIT#, SSI input pin, SDHI input pin, MMC input pin, PDC input pin		$V_{CC} \times 0.8$	—	$V_{CC} + 0.3$		
	ETHERC input pin		2.3	—	$V_{CC} + 0.3$		
	D0 to D31		$V_{CC} \times 0.7$	—	$V_{CC} + 0.3$		
	RIIC (SMBus)		2.1	—	$V_{CC} + 0.3$		
Input low voltage (except for Schmitt trigger input pin)	MD pin, EMLE	V_{IL}	-0.3	—	$V_{CC} \times 0.1$	V	
	EXTAL, RSPI input pin, EXDMAC input pin, WAIT#, SSI input pin, SDHI input pin, MMC input pin, PDC input pin		-0.3	—	$V_{CC} \times 0.2$		
	D0 to D31		-0.3	—	$V_{CC} \times 0.3$		
	RIIC (SMBus)		-0.3	—	0.8		

Note 1. This does not include the pins, which are multiplexed as ports for 5 V tolerant.

Note 2. Ports 07, 11 to 17, 20, 21, 30 to 33, 67, and C0 to C3 are 5 V tolerant.

Note 3. For P32, P31, and P30, input as follows when the V_{BATT} power supply is selected.

V_{IH} Min. = $V_{BATT} \times 0.8$, V_{IH} Max. = $V_{BATT} + 0.3$, V_{IL} Min. = -0.3, V_{IL} Max. = $V_{BATT} \times 0.2$ ($V_{BATT} = 2.0$ to 3.6 V)

Table 5.4 DC Characteristics (2)

Conditions: $V_{CC} = AVCC0 = AVCC1 = V_{CC_USB} = V_{BATT} = 2.7$ to 3.6 V, $2.7 \leq V_{REFH0} \leq AVCC0$,
 $V_{CC_USBA} = AVCC_USBA = 3.0$ to 3.6 V,
 $V_{SS} = AVSS0 = AVSS1 = V_{REFL0} = V_{SS_USB} = V_{SS1_USBA} = V_{SS2_USBA} = PV_{SS_USBA} = AV_{SS_USBA} = 0$ V,
 $T_a = T_{opr}$

Item	Symbol	Min.	Typ.	Max.	Unit	Test Conditions
Output high voltage	All output pins	V_{OH}	$V_{CC} - 0.5$	—	—	V $I_{OH} = -1$ mA
Output low voltage	All output pins (except for RIIC pins and ETHERC output pin)	V_{OL}	—	—	0.5	V $I_{OL} = 1.0$ mA
	RIIC output pin		—	—	0.4	$I_{OL} = 3.0$ mA
			—	—	0.6	$I_{OL} = 6.0$ mA
	RIIC output pin (only P12 and P13 in channel 0)	V_{OL}	—	—	0.4	V $I_{OL} = 15.0$ mA (ICFER.FMPE = 1)
			—	0.4	—	$I_{OL} = 20.0$ mA (ICFER.FMPE = 1)
ETHERC output pin	V_{OL}	—	—	0.4	V $I_{OL} = 1.0$ mA	
Input leakage current	RES#, MD pin, EMLE*1, BSCANP*1, NMI	$ I_{in} $	—	—	1.0	μ A $V_{in} = 0$ V $V_{in} = V_{CC}$
Three-state leakage current (off state)	Other than ports for 5 V tolerant	$ I_{TSI} $	—	—	1.0	μ A $V_{in} = 0$ V $V_{in} = V_{CC}$
	Ports for 5 V tolerant		—	—	5.0	$V_{in} = 0$ V $V_{in} = 5.5$ V
Input pull-up MOS current	Ports 0 to 2, 30 to 34, 36, 37, 4 to G, J3, J5	I_p	-300	—	-10	μ A $V_{CC} = 2.7$ to 3.6 V $V_{in} = 0$ V
Input pull-down MOS current	EMLE, BSCANP	I_p	10	—	300	μ A $V_{in} = V_{CC}$
Input capacitance	All input pins (except for ports 03, 05, 12, 13, 16, 17, EMLE, BSCANP, USB0_DP, USB0_DM, USBA_DP, and USBA_DM)	C_{in}	—	—	8	pF $V_{bias} = 0$ V $V_{amp} = 20$ mV $f = 1$ MHz $T_a = 25^\circ$ C
	Ports 03, 05, 12, 13, 16, 17, EMLE, BSCANP, USB0_DP, USB0_DM, USBA_DP, and USBA_DM		—	—	16	

Note 1. The input leakage current value at the EMLE and BSCANP pins are only when $V_{in} = 0$ V.

Table 5.5 DC Characteristics (3)

Conditions: $V_{CC} = AV_{CC0} = AV_{CC1} = V_{REFH0} = V_{CC_USB} = 2.7$ to 3.6 V, $2.7 \leq V_{REFH0} \leq AV_{CC0}$,
 $V_{CC_USBA} = AV_{CC_USBA} = 3.0$ to 3.6 V,
 $V_{SS} = AV_{SS0} = AV_{SS1} = V_{REFL0} = V_{SS_USB} = V_{SS1_USBA} = V_{SS2_USBA} = PV_{SS_USBA} = AV_{SS_USBA} = 0$ V,
 $T_a = T_{opr}$

Item		Symbol	Min.	Typ.	Max.	Unit	Test Conditions				
Supply current*1	Max.*2	I_{CC} *3	—	—	220	mA	ICLK = 240 MHz PCLKA = 120 MHz PCLKB = 60 MHz PCLKC = 60 MHz PCLKD = 60 MHz FCLK = 60 MHz BCLK = 120 MHz BCLK pin = 60 MHz				
	Normal		Peripheral function clock signal supplied*4	—	52			—			
			Peripheral function clock signal stopped*4	—	28			—			
	CoreMark		Peripheral function clock signal stopped*4	—	41			—			
	Sleep mode: The clock signal to peripheral modules is supplied*4		—	37	108						
	All-module-clock-stop mode (reference value)		—	15	80						
	Increased by BGO operation*5		Reading from the code flash memory while the data flash memory is being programmed	—	7			—			
			Reading from the code flash memory while the code flash memory is being programmed	—	10			—			
	Low-speed operating mode 1: Supply of the clock signal to peripheral modules is stopped*4		—	4.4	—			All clocks 1 MHz			
	Low-speed operating mode 2: Supply of the clock signal to peripheral modules is stopped*4		—	3	—			All clocks 32.768 kHz			
	Software standby mode		—	1.9	59						
	Deep software standby mode		Power supplied to standby RAM and USB resume detecting unit (USBb only)		—			25	75	μ A	
			Power not supplied to standby RAM and USB resume detecting unit (USBb only)	Power-on reset circuit and low-power consumption function disabled*6	—			12.5	26		
				Power-on reset circuit and low-power consumption function enabled*7	—			3.1	13.5		
			Increased by RTC operation	When a crystal resonator for low clock loads is in use	—			0.6	—		
When a crystal resonator for standard clock loads is in use		—		2.0	—						
RTC operating while VCC is off (with the battery backup function, only the RTC and sub-clock oscillator operate)		When a crystal resonator for low clock loads is in use	—	0.9	—	$V_{BATT} = 2.0$ V, $V_{CC} = 0$ V					
			—	1.6	—	$V_{BATT} = 3.3$ V, $V_{CC} = 0$ V					
	When a crystal resonator for standard clock loads is in use	—	1.7	—	$V_{BATT} = 2.0$ V, $V_{CC} = 0$ V						
		—	3.3	—	$V_{BATT} = 3.3$ V, $V_{CC} = 0$ V						

Note 1. Supply current values are with all output pins unloaded and all input pull-up MOSs in the off state.

Note 2. Supply of the clock signal to peripheral modules is stopped in this state. This does not include operations as BGO (background operations).

Note 3. I_{CC} depends on f (ICLK) as follows. (ICLK:PCLKA:PCLKB/PCLKC/PCLKD:BCLK:BCLK pin = 10:5:2.5:5:2.5 when EXTAL = 24 MHz)
 I_{CC} Max. = $0.47 \times f + 107$ (max. operation in high-speed operating mode)
 I_{CC} Typ. = $0.09 \times f + 7$ (normal operation in high-speed operating mode)
 I_{CC} Typ. = $0.50 \times f + 4$ (low-speed operating mode 1)
 I_{CC} Max. = $0.14 \times f + 74$ (sleep mode)

Note 4. This does not include operations as BGO (background operations). Whether supply of the clock signal to peripheral modules continues or is stopped only depends on the state determined by the settings of the bits in module stop control registers A to D. The setting for the peripheral module clock stopped state is FCLK = BCLK = PCLKA = PCLKB = PCLKC = PCLKD = BCLK pin = 3.75 MHz (division by 64).

Note 5. This is the increase for programming or erasure of the code flash memory (limitations apply to the combinations of ranges in which writing proceed) or data flash memory during program execution in the code flash memory.

Note 6. The low power consumption function is disabled and DEEPCUT[1:0] = 01b.

Note 7. The low power consumption function is enabled and DEEPCUT[1:0] = 11b.

Table 5.6 DC Characteristics (4)

Conditions: $VCC = AVCC0 = AVCC1 = VREFH0 = VCC_USB = 2.7$ to 3.6 V, $2.7 \leq VREFH0 \leq AVCC0$,

$VCC_USBA = AVCC_USBA = 3.0$ to 3.6 V,

$VSS = AVSS0 = AVSS1 = VREFL0 = VSS_USB = VSS1_USBA = VSS2_USBA = PVSS_USBA = AVSS_USBA = 0$ V,

$T_a = T_{opr}$

Item		Symbol	Min.	Typ.	Max.	Unit	Test Conditions	
Analog power supply current*1	During 12-bit A/D conversion (unit 0)	I_{CC}	—	0.7	1.1	mA	IAVCC0_AD	
	During 12-bit A/D conversion (unit 0) with the channel-dedicated sample-and-hold circuits for 3 channels operating		—	2.2	3.3	mA	IAVCC0_AD+SH	
	During 12-bit A/D conversion (unit 1)		—	0.7	1.1	mA	IAVCC1_AD	
	During 12-bit A/D conversion (unit 1) with the temperature sensor operating		—	0.7	2.3	mA	IAVCC1_AD+TEMP	
	During D/A conversion (per unit)		Without AMP output	—	0.24	0.4	mA	IAVCC1_DA
			With AMP output	—	0.45	0.7	mA	
	Waiting for A/D, D/A, or temperature sensor conversion (all units)		—	0.9	1.6	mA	IAVCC0 + IAVCC1	
A/D, D/A converter, temperature sensor in standby mode (all units)	—	1.3	5.0	μ A	IAVCC0 + IAVCC1			
Reference power supply current	During 12-bit A/D conversion (unit 0)	I_{REFH}	—	70	120	μ A	IVREFH0	
	Waiting for 12-bit A/D conversion (unit 0)		—	0.07	0.5	μ A	IVREFH0	
	12-bit A/D converter in standby mode (unit 0)		—	0.07	0.5	μ A	IVREFH0	
USB operating current	Low speed	USBb	$I_{CCUSBLS}$	—	3.5	6.5	mA	VCC_USB
		USBA		—	10.5	13.5	mA	VCC_USBA = AVCC_USBA (PHYSET.HSEB = 0)
		USBA		—	2.8	3.6	mA	VCC_USBA = AVCC_USBA (PHYSET.HSEB = 1)
	Full speed	USBb	$I_{CCUSBFS}$	—	4.0	10.0	mA	VCC_USB
		USBA		—	14.0	22.0	mA	VCC_USBA = AVCC_USBA (PHYSET.HSEB = 0)
		USBA		—	6.5	13.0	mA	VCC_USBA = AVCC_USBA (PHYSET.HSEB = 1)
	High speed	USBA	$I_{CCUSBHS}$	—	50.0	65.0	mA	VCC_USBA = AVCC_USBA
	Standby mode (direct power down)	USBA	$I_{CCUSBSBY}$	—	0.1	3.0	μ A	VCC_USBA = AVCC_USBA
	RAM standby voltage		V_{RAM}	2.7	—	—	V	
VCC rising gradient		$SrVCC$	8.4	—	20000	μ s/V		
VCC falling gradient*2		$SfVCC$	8.4	—	—	μ s/V		

Note 1. The reference power supply current is included in the power supply current value for 12-bit A/D conversion (unit 1) and D/A conversion.

Note 2. This applies when V_{BATT} is used.

Table 5.7 Thermal Resistances (Reference)

Item	Package	Symbol	Max.	Unit	Test Conditions	
Thermal resistance	PLQP0176KB-A	θ_{ja}	39.1	°C/W	JESD51-2 and JESD51-7 compliant	
	PLQP0144KA-A		40.4			
	PLQP0100KB-A		41.3			
	PLBG0176GA-A		28.4			JESD51-2 and JESD51-9 compliant
	PTLG0177KA-A		27.7			
	PTLG0145KA-A		28.2			
	PTLG0100JA-A		20.6			
	PLQP0176KB-A	Ψ_{jt}	0.5	°C/W	JESD51-2 and JESD51-7 compliant	
	PLQP0144KA-A		0.5			
	PLQP0100KB-A		0.5			
	PLBG0176GA-A		0.2			JESD51-2 and JESD51-9 compliant
	PTLG0177KA-A		0.2			
	PTLG0145KA-A		0.2			
	PTLG0100JA-A		0.2			

Note: The values are reference values when the 4-layer printed circuit board is used. Thermal resistance depends on the number of layers and size of the board. For details, refer to the JEDEC standards.

Table 5.8 Permissible Output Currents

Conditions: $V_{CC} = AVCC0 = AVCC1 = V_{CC_USB} = V_{BATT} = 2.7$ to 3.6 V, $2.7 \leq V_{REFH0} \leq AVCC0$,
 $V_{CC_USBA} = AVCC_USBA = 3.0$ to 3.6 V,
 $V_{SS} = AVSS0 = AVSS1 = V_{REFL0} = V_{SS_USB} = V_{SS1_USBA} = V_{SS2_USBA} = PV_{SS_USBA} = AV_{SS_USBA} = 0$ V,
 $T_a = T_{opr}$

Item	Symbol	Min.	Typ.	Max.	Unit	
Permissible output low current (average value per pin)	All output pins*1 Normal drive	I_{OL}	—	—	2.0	mA
	All output pins*2 High drive	I_{OL}	—	—	3.8	mA
Permissible output low current (max. value per pin)	All output pins*1 Normal drive	I_{OL}	—	—	4.0	mA
	All output pins*2 High drive	I_{OL}	—	—	7.6	mA
Permissible output low current (total)	Total of all output pins	ΣI_{OL}	—	—	80	mA
Permissible output high current (average value per pin)	All output pins*1 Normal drive	I_{OH}	—	—	-2.0	mA
	USB_DPUPE pin*2 High drive	I_{OH}	—	—	-3.8	mA
Permissible output high current (max. value per pin)	All output pins*1 Normal drive	I_{OH}	—	—	-4.0	mA
	All output pins*2 High drive	I_{OH}	—	—	-7.6	mA
Permissible output high current (total)	Total of all output pins	ΣI_{OH}	—	—	-80	mA

Caution: To protect the LSI's reliability, the output current values should not exceed the values in this table.

Note 1. This is the value when normal driving ability is set with a pin for which normal driving ability is selectable.

Note 2. This is the value when high driving ability is set with a pin for which normal driving ability is selectable or the value of the pin to which high driving ability is fixed.

5.3 AC Characteristics

Table 5.9 Operating Frequency (High-Speed Operating Mode)

Conditions: $V_{CC} = AVCC0 = AVCC1 = V_{CC_USB} = V_{BATT} = 2.7$ to 3.6 V, $2.7 \leq V_{REFH0} \leq AVCC0$,
 $V_{CC_USBA} = AVCC_USBA = 3.0$ to 3.6 V,
 $V_{SS} = AVSS0 = AVSS1 = V_{REFL0} = V_{SS_USB} = V_{SS1_USBA} = V_{SS2_USBA} = PV_{SS_USBA} = AV_{SS_USBA} = 0$ V,
 $T_a = T_{opr}$

Item		Symbol	Min.	Typ.	Max.	Unit	
Operating frequency	System clock (ICKL)	f	—	—	240	MHz	
	Peripheral module clock (PCLKA)		—	—	120		
	Peripheral module clock (PCLKB)		—	—	60		
	Peripheral module clock (PCLKC)		—	—	60		
	Peripheral module clock (PCLKD)		—	—	60		
	Flash-IF clock (FCLK)		—*1	—	60		
	External bus clock (BCLK)		Packages with 177 to 144 pins only	—	—		120
			Package with 100 pins only	—	—		60
	BCLK pin output		Packages with 177 to 144 pins only	—	—		60
			Package with 100 pins only	—	—		30
	SDRAM clock (SDCLK)		Packages with 177 to 144 pins only	—	—		60
	SDCLK pin output		Packages with 177 to 144 pins only	—	—		60

Note 1. The FCLK must run at a frequency of at least 4 MHz when changing the flash memory contents.

Table 5.10 Operating Frequency (Low-Speed Operating Mode 1)

Conditions: $V_{CC} = AVCC0 = AVCC1 = V_{CC_USB} = V_{BATT} = 2.7$ to 3.6 V, $2.7 \leq V_{REFH0} \leq AVCC0$,
 $V_{CC_USBA} = AVCC_USBA = 3.0$ to 3.6 V,
 $V_{SS} = AVSS0 = AVSS1 = V_{REFL0} = V_{SS_USB} = V_{SS1_USBA} = V_{SS2_USBA} = PV_{SS_USBA} = AV_{SS_USBA} = 0$ V,
 $T_a = T_{opr}$

Item		Symbol	Min.	Typ.	Max.	Unit	
Operating frequency	System clock (ICKL)	f	—	—	1	MHz	
	Peripheral module clock (PCLKA)		—	—	1		
	Peripheral module clock (PCLKB)		—	—	1		
	Peripheral module clock (PCLKC)*1		—	—	1		
	Peripheral module clock (PCLKD)*1		—	—	1		
	Flash-IF clock (FCLK)		—	—	1		
	External bus clock (BCLK)		Packages with 177 to 144 pins only	—	—		1
			Package with 100 pins only	—	—		1
	BCLK pin output		Packages with 177 to 144 pins only	—	—		1
			Package with 100 pins only	—	—		1
	SDRAM clock (SDCLK)		Packages with 177 to 144 pins only	—	—		1
	SDCLK pin output		Packages with 177 to 144 pins only	—	—		1

Note 1. When the 12-bit A/D converter is used, the frequency must be set to at least 1 MHz.

Table 5.11 Operating Frequency (Low-Speed Operating Mode 2)

Conditions: $VCC = AVCC0 = AVCC1 = VCC_USB = V_{BATT} = 2.7$ to 3.6 V, $2.7 \leq VREFH0 \leq AVCC0$,
 $VCC_USBA = AVCC_USBA = 3.0$ to 3.6 V,
 $VSS = AVSS0 = AVSS1 = VREFL0 = VSS_USB = VSS1_USBA = VSS2_USBA = PVSS_USBA = AVSS_USBA = 0$ V,
 $T_a = T_{opr}$

Item		Symbol	Min.	Typ.	Max.	Unit	
Operating frequency	System clock (ICLK)	f	32	—	264	kHz	
	Peripheral module clock (PCLKA)		—	—	264		
	Peripheral module clock (PCLKB)		—	—	264		
	Peripheral module clock (PCLKC)*1		—	—	264		
	Peripheral module clock (PCLKD)*1		—	—	264		
	Flash-IF clock (FCLK)		32	—	264		
	External bus clock (BCLK)		Packages with 177 to 144 pins only	—	—		264
			Package with 100 pins only	—	—		264
	BCLK pin output		Packages with 177 to 144 pins only	—	—		264
			Package with 100 pins only	—	—		264
	SDRAM clock (SDCLK)		Packages with 177 to 144 pins only	—	—		264
	SDCLK pin output		Packages with 177 to 144 pins only	—	—		264

Note 1. The 12-bit A/D converter cannot be used.

5.3.1 Reset Timing

Table 5.12 Reset Timing

Conditions: $V_{CC} = AV_{CC0} = AV_{CC1} = V_{CC_USB} = V_{BATT} = 2.7$ to 3.6 V, $2.7 \leq V_{REFH0} \leq AV_{CC0}$,
 $V_{CC_USBA} = AV_{CC_USBA} = 3.0$ to 3.6 V,
 $V_{SS} = AV_{SS0} = AV_{SS1} = V_{REFL0} = V_{SS_USB} = V_{SS1_USBA} = V_{SS2_USBA} = PV_{SS_USBA} = AV_{SS_USBA} = 0$ V,
 $T_a = T_{opr}$

Item		Symbol	Min.	Typ.	Max.	Unit	Test Conditions
RES# pulse width	Power-on	t_{RESWP}	1	—	—	ms	Figure 5.1
	Deep software standby mode	t_{RESWD}	0.6	—	—	ms	Figure 5.2
	Software standby mode, low-speed operating mode 2	t_{RESWS}	0.3	—	—	ms	
	Programming or erasure of the code flash memory, or programming, erasure or blank checking of the data flash memory	t_{RESWF}	200	—	—	μ s	
	Other than above	t_{RESW}	200	—	—	μ s	
Waiting time after release from the RES# pin reset		t_{RESWT}	62	—	63	t_{Lcyc}	Figure 5.1
Internal reset time (independent watchdog timer reset, watchdog timer reset, software reset)		t_{RESW2}	108	—	116	t_{Lcyc}	



Figure 5.1 Reset Input Timing at Power-On



Figure 5.2 Reset Input Timing

5.3.2 Clock Timing

Table 5.13 BCLK Pin Output, SDCLK Pin Output Clock Timing

Conditions: $V_{CC} = AV_{CC0} = AV_{CC1} = V_{CC_USB} = V_{BATT} = 2.7$ to 3.6 V, $2.7 \leq V_{REFH0} \leq AV_{CC0}$,
 $V_{CC_USBA} = AV_{CC_USBA} = 3.0$ to 3.6 V,
 $V_{SS} = AV_{SS0} = AV_{SS1} = V_{REFL0} = V_{SS_USB} = V_{SS1_USBA} = V_{SS2_USBA} = PV_{SS_USBA} = AV_{SS_USBA} = 0$ V,
 $T_a = T_{opr}$

Item	Symbol	Min.	Typ.	Max.	Unit	Test Conditions
BCLK pin output cycle time	t_{Bcyc}	16.6	—	—	ns	Figure 5.3
		33.2	—	—	ns	
BCLK pin output high pulse width	t_{CH}	3.3	—	—	ns	
BCLK pin output low pulse width	t_{CL}	3.3	—	—	ns	
BCLK pin output rising time	t_{Cr}	—	—	5	ns	
BCLK pin output falling time	t_{Cf}	—	—	5	ns	
SDCLK pin output cycle time	t_{SDcyc}	16.6	—	—	ns	
SDCLK pin output high pulse width		t_{CH}	3.3	—	—	ns
SDCLK pin output low pulse width		t_{CL}	3.3	—	—	ns
SDCLK pin output rising time		t_{Cr}	—	—	5	ns
SDCLK pin output falling time		t_{Cf}	—	—	5	ns



Figure 5.3 BCLK Pin and SDCLK Pin Output Timing

Table 5.14 EXTAL Clock Timing

Conditions: $VCC = AVCC0 = AVCC1 = VCC_USB = V_{BATT} = 2.7$ to 3.6 V, $2.7 \leq VREFH0 \leq AVCC0$,
 $VCC_USBA = AVCC_USBA = 3.0$ to 3.6 V,
 $VSS = AVSS0 = AVSS1 = VREFL0 = VSS_USB = VSS1_USBA = VSS2_USBA = PVSS_USBA = AVSS_USBA = 0$ V,
 $T_a = T_{opr}$

Item	Symbol	Min.	Typ.	Max.	Unit	Test Conditions
EXTAL external clock input cycle time	t_{EXcyc}	41.66	—	—	ns	Figure 5.4
EXTAL external clock input high pulse width	t_{EXH}	15.83	—	—	ns	
EXTAL external clock input low pulse width	t_{EXL}	15.83	—	—	ns	
EXTAL external clock rising time	t_{EXr}	—	—	5	ns	
EXTAL external clock falling time	t_{EXf}	—	—	5	ns	

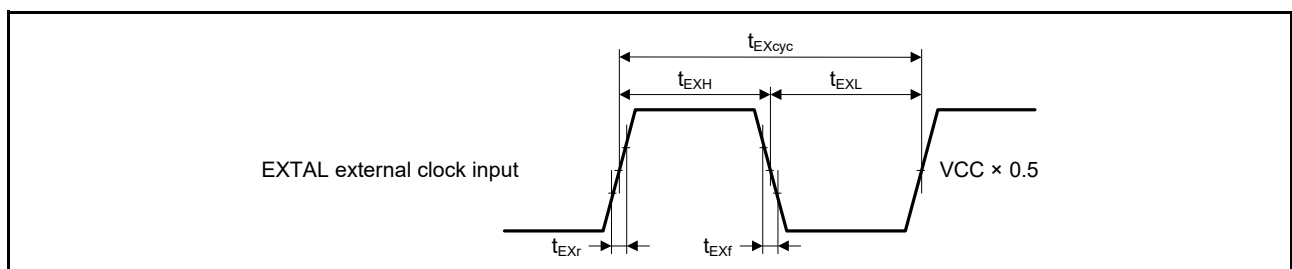

Figure 5.4 EXTAL External Clock Input Timing

Table 5.15 Main Clock Timing

Conditions: $VCC = AVCC0 = AVCC1 = VCC_USB = V_{BATT} = 2.7$ to 3.6 V, $2.7 \leq VREFH0 \leq AVCC0$,
 $VCC_USBA = AVCC_USBA = 3.0$ to 3.6 V,
 $VSS = AVSS0 = AVSS1 = VREFL0 = VSS_USB = VSS1_USBA = VSS2_USBA = PVSS_USBA = AVSS_USBA = 0$ V,
 $T_a = T_{opr}$

Item	Symbol	Min.	Typ.	Max.	Unit	Test Conditions
Main clock oscillation frequency	f_{MAIN}	8	—	24	MHz	
Main clock oscillator stabilization time (crystal)	$t_{MAINOSC}$	—	—	—*1	ms	Figure 5.5
Main clock oscillator stabilization wait time (crystal)	$t_{MAINOSCWT}$	—	—	—*2	ms	

Note 1. When using a main clock, ask the manufacturer of the oscillator to evaluate its oscillation. Refer to the results of evaluation provided by the manufacturer for the oscillation stabilization time.

Note 2. The number of cycles selected by the value of the MOSCWTCR.MSTS[7:0] bits determines the main-clock oscillation stabilization wait time in accord with the formula below.

$$t_{MAINOSCWT} = [(MSTS[7:0] \text{ bits} \times 32) + 10] / f_{LOCO}$$

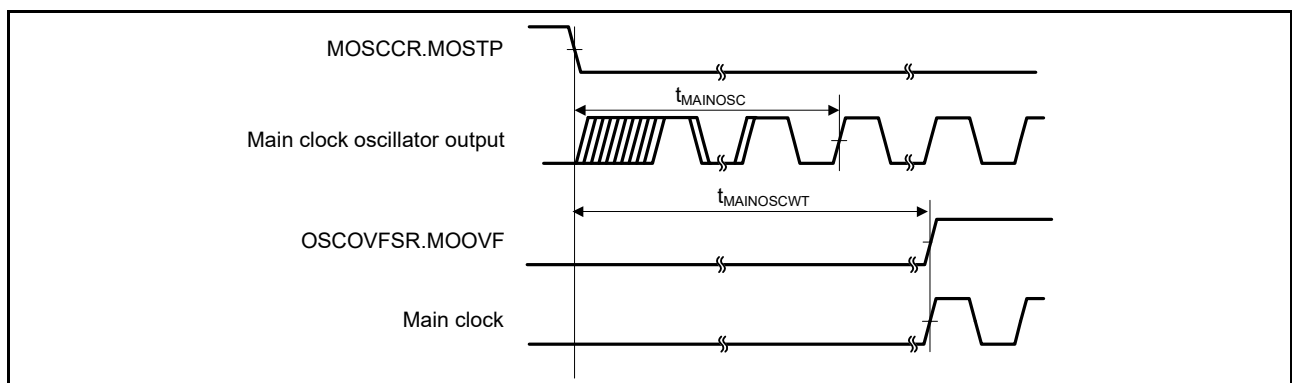

Figure 5.5 Main Clock Oscillation Start Timing

Table 5.16 LOCO and IWDT-Dedicated Low-Speed Clock Timing

Conditions: $VCC = AVCC0 = AVCC1 = VCC_USB = V_{BATT} = 2.7$ to 3.6 V, $2.7 \leq VREFH0 \leq AVCC0$,
 $VCC_USBA = AVCC_USBA = 3.0$ to 3.6 V,
 $VSS = AVSS0 = AVSS1 = VREFL0 = VSS_USB = VSS1_USBA = VSS2_USBA = PVSS_USBA = AVSS_USBA = 0$ V,
 $T_a = T_{opr}$

Item	Symbol	Min.	Typ.	Max.	Unit	Test Conditions
LOCO clock cycle time	t_{Lcyc}	3.78	4.16	4.63	μs	
LOCO clock oscillation frequency	f_{LOCO}	216	240	264	kHz	
LOCO clock oscillation stabilization wait time	t_{LOCOWT}	—	—	44	μs	Figure 5.6
IWDT-dedicated low-speed clock cycle time	t_{iLcyc}	7.57	8.33	9.26	μs	
IWDT-dedicated low-speed clock oscillation frequency	f_{iLOCO}	108	120	132	kHz	
IWDT-dedicated low-speed clock oscillation stabilization wait time	$t_{iLOCOWT}$	—	142	190	μs	Figure 5.7



Figure 5.6 LOCO Clock Oscillation Start Timing



Figure 5.7 IWDT-dedicated Low-Speed Clock Oscillation Start Timing

Table 5.17 HOCO Clock Timing

Conditions: $VCC = AVCC0 = AVCC1 = VCC_USB = V_{BATT} = 2.7$ to 3.6 V, $2.7 \leq VREFH0 \leq AVCC0$,
 $VCC_USBA = AVCC_USBA = 3.0$ to 3.6 V,
 $VSS = AVSS0 = AVSS1 = VREFL0 = VSS_USB = VSS1_USBA = VSS2_USBA = PVSS_USBA = AVSS_USBA = 0$ V,
 $T_a = T_{opr}$

Item	Symbol	Min.	Typ.	Max.	Unit	Test Conditions
HOCO clock oscillation frequency	f_{HOCO}	15.61	16	16.39	MHz	$-20^{\circ}\text{C} \leq T_a \leq 85^{\circ}\text{C}$
		17.56	18	18.44	MHz	
		19.52	20	20.48	MHz	
		$-40^{\circ}\text{C} \leq T_a < -20^{\circ}\text{C}$	15.52	16	16.48	MHz
			17.46	18	18.54	MHz
			19.40	20	20.60	MHz
HOCO clock oscillation stabilization wait time	t_{HOCOWT}	—	105	149	μs	Figure 5.8
HOCO clock power supply stabilization time	t_{HOCOP}	—	—	150	μs	Figure 5.9

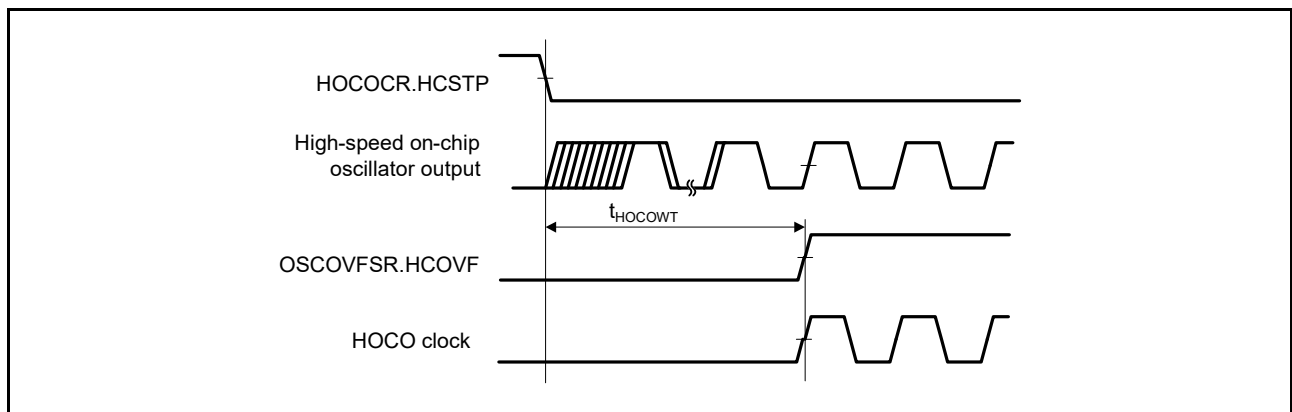

Figure 5.8 HOCO Clock Oscillation Start Timing (Oscillation is Started by Setting the HOCO CR.HCSTP Bit)

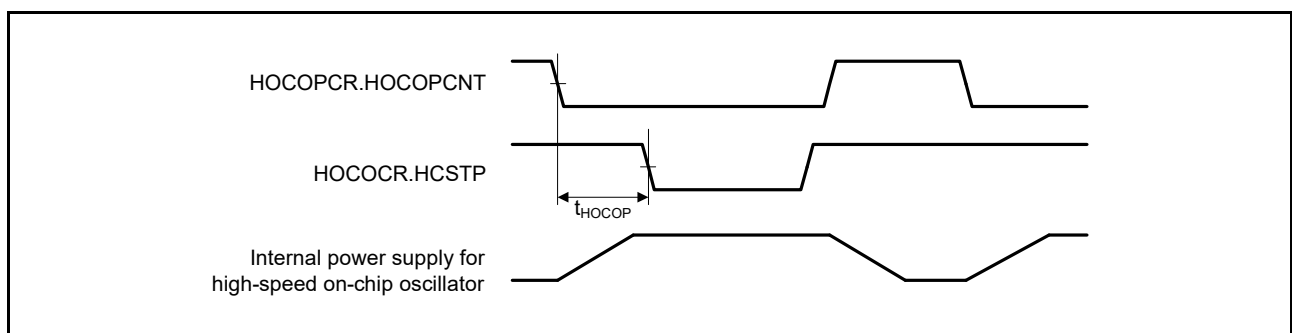

Figure 5.9 High-Speed On-Chip Oscillator Power Supply Control Timing

Table 5.18 PLL Clock Timing

Conditions: $V_{CC} = AVCC0 = AVCC1 = V_{CC_USB} = V_{BATT} = 2.7$ to 3.6 V, $2.7 \leq V_{REFH0} \leq AVCC0$,
 $V_{CC_USBA} = AVCC_USBA = 3.0$ to 3.6 V,
 $V_{SS} = AVSS0 = AVSS1 = V_{REFL0} = V_{SS_USB} = V_{SS1_USBA} = V_{SS2_USBA} = PV_{SS_USBA} = AV_{SS_USBA} = 0$ V,
 $T_a = T_{opr}$

Item	Symbol	Min.	Typ.	Max.	Unit	Test Conditions
PLL clock oscillation frequency	f_{PLL}	120	—	240	MHz	
PLL clock oscillation stabilization wait time	t_{PLLWT}	—	259	320	μ s	Figure 5.10



Figure 5.10 PLL Clock Oscillation Start Timing

Table 5.19 Sub-Clock Timing

Conditions: $V_{CC} = AVCC0 = AVCC1 = V_{CC_USB} = 2.7$ to 3.6 V, $2.7 \leq V_{REFH0} \leq AVCC0$,
 $V_{CC_USBA} = AVCC_USBA = 3.0$ to 3.6 V,
 $V_{SS} = AVSS0 = AVSS1 = V_{REFL0} = V_{SS_USB} = V_{SS1_USBA} = V_{SS2_USBA} = PV_{SS_USBA} = AV_{SS_USBA} = 0$ V,
 $V_{BATT} = 2.0$ to 3.6 V, $T_a = T_{opr}$

Item	Symbol	Min.	Typ.	Max.	Unit	Test Conditions
Sub-clock oscillation frequency	f_{SUB}	—	32.768	—	kHz	
Sub-clock oscillation stabilization time	t_{SUBOSC}	—	—	*1	s	Figure 5.11
Sub-clock oscillation stabilization wait time	$t_{SUBOSCWT}$	—	—	*2	s	

Note 1. When using a sub-clock, ask the manufacturer of the oscillator to evaluate its oscillation. Refer to the results of evaluation provided by the manufacturer for the oscillation stabilization time.

Note 2. The number of cycles selected by the value of the SOSWTCR.SSTS[7:0] bits determines the sub-clock oscillation stabilization wait time in accord with the formula below.

$$t_{SUBOSCWT} = [(SSTS[7:0] \text{ bits} \times 16384) + 10] / f_{LOCO}$$



Figure 5.11 Sub-Clock Oscillation Start Timing

5.3.3 Timing of Recovery from Low Power Consumption Modes

Table 5.20 Timing of Recovery from Low Power Consumption Modes (1)

Conditions: $V_{CC} = AV_{CC0} = AV_{CC1} = V_{CC_USB} = V_{BATT} = 2.7$ to 3.6 V, $2.7 \leq V_{REFH0} \leq AV_{CC0}$,
 $V_{CC_USBA} = AV_{CC_USBA} = 3.0$ to 3.6 V,
 $V_{SS} = AV_{SS0} = AV_{SS1} = V_{REFL0} = V_{SS_USB} = V_{SS1_USBA} = V_{SS2_USBA} = PV_{SS_USBA} = AV_{SS_USBA} = 0$ V,
 $T_a = T_{opr}$

Item			Symbol	Min.	Typ.	Max.		Unit	Test Conditions
						$t_{SBYOSCWT}^{*2}$	t_{SBYSEQ}^{*3}		
Recovery time after cancellation of software standby mode*1	Crystal resonator connected to main clock oscillator	Main clock oscillator operating	t_{SBYMC}	—	—	$\{(MSTS[7:0] \text{ bit} \times 32) + 76\} / 0.216$	$100 \mu\text{s} + 7/f_{iCLK} + 2n/f_{MAIN}$	μs	Figure 5.12
		Main clock oscillator and PLL circuit operating	t_{SBYPC}			$\{(MSTS[7:0] \text{ bit} \times 32) + 138\} / 0.216$	$100 \mu\text{s} + 7/f_{iCLK} + 2n/f_{PLL}$		
	External clock input to main clock oscillator	Main clock oscillator operating	t_{SBYEX}			352	$100 \mu\text{s} + 7/f_{iCLK} + 2n/f_{EXMAIN}$		
		Main clock oscillator and PLL circuit operating	t_{SBYPE}			639	$100 \mu\text{s} + 7/f_{iCLK} + 2n/f_{PLL}$		
	Sub-clock oscillator operating		t_{SBYSC}			$\{(SSTS[7:0] \text{ bit} \times 16384) + 13\} / 0.216 + 10/f_{FCLK}$	$100 \mu\text{s} + 4/f_{iCLK} + 2n/f_{SUB}$		
	High-speed on-chip oscillator operating	High-speed on-chip oscillator operating	t_{SBYHO}			454	$100 \mu\text{s} + 7/f_{iCLK} + 2n/f_{HOCO}$		
		High-speed on-chip oscillator operating and PLL circuit operating	t_{SBYPH}			741	$100 \mu\text{s} + 7/f_{iCLK} + 2n/f_{PLL}$		
	Low-speed on-chip oscillator operating*4		t_{SBYLO}			338	$100 \mu\text{s} + 7/f_{iCLK} + 2n/f_{LOCO}$		

Note 1. The time for return after release from software standby is determined by the value obtained by adding the oscillation stabilization waiting time ($t_{SBYOSCWT}$) and the time required for operations by the software standby release sequencer (t_{SBYSEQ}).

Note 2. When several oscillators were running before the transition to software standby, the greatest value of the oscillation stabilization waiting time $t_{SBYOSCWT}$ is selected.

Note 3. For n, the greatest value is selected from among the internal clock division settings.

Note 4. This condition applies when $f_{iCLK}:f_{FCLK} = 1:1, 2:1, \text{ or } 4:1$.



Figure 5.12 Software Standby Mode Cancellation Timing

Table 5.21 Timing of Recovery from Low Power Consumption Modes (2)

Conditions: $V_{CC} = AVCC0 = AVCC1 = V_{CC_USB} = V_{BATT} = 2.7$ to 3.6 V, $2.7 \leq V_{REFH0} \leq AVCC0$,
 $V_{CC_USBA} = AVCC_USBA = 3.0$ to 3.6 V,
 $V_{SS} = AVSS0 = AVSS1 = V_{REFL0} = V_{SS_USB} = V_{SS1_USBA} = V_{SS2_USBA} = PV_{SS_USBA} = AV_{SS_USBA} = 0$ V,
 $T_a = T_{opr}$

Item	Symbol	min	typ	max	Unit	Test Conditions
Recovery time after cancellation of deep software standby mode	t_{DSBY}	—	—	0.9	ms	Figure 5.13
Wait time after cancellation of deep software standby mode	t_{DSBYWT}	31	—	32	t_{Lcyc}	

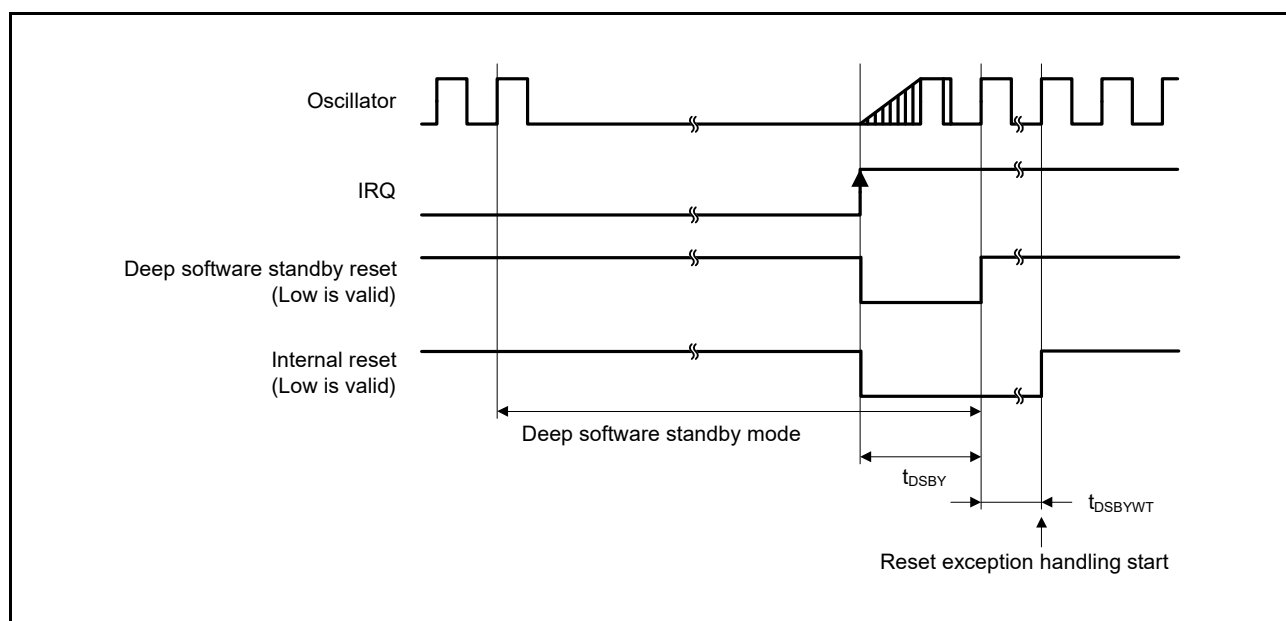

Figure 5.13 Deep Software Standby Mode Cancellation Timing

5.3.4 Control Signal Timing

Table 5.22 Control Signal Timing

Conditions: $VCC = AVCC0 = AVCC1 = VCC_USB = V_{BATT} = 2.7$ to 3.6 V, $2.7 \leq VREFH0 \leq AVCC0$,
 $VCC_USBA = AVCC_USBA = 3.0$ to 3.6 V,
 $VSS = AVSS0 = AVSS1 = VREFL0 = VSS_USB = VSS1_USBA = VSS2_USBA = PVSS_USBA = AVSS_USBA = 0$ V,
 $PLCKB = 8$ to 60 MHz, $T_a = T_{opr}$

Item	Symbol	Min.*1	Typ.	Max.	Unit	Test Conditions*1
NMI pulse width	t_{NMIW}	200	—	—	ns	$t_{PBcyc} \times 2 \leq 200$ ns, Figure 5.14
		$t_{PBcyc} \times 2$	—	—	ns	$t_{PBcyc} \times 2 > 200$ ns, Figure 5.14
IRQ pulse width	t_{IRQW}	200	—	—	ns	$t_{PBcyc} \times 2 \leq 200$ ns, Figure 5.15
		$t_{PBcyc} \times 2$	—	—	ns	$t_{PBcyc} \times 2 > 200$ ns, Figure 5.15

Note 1. t_{PBcyc} : PCLKB cycle



Figure 5.14 NMI Interrupt Input Timing



Figure 5.15 IRQ Interrupt Input Timing

5.3.5 Bus Timing

Table 5.23 Bus Timing

Conditions: $V_{CC} = AVCC0 = AVCC1 = V_{CC_USB} = V_{BATT} = 2.7$ to 3.6 V, $2.7 \leq V_{REFH0} \leq AVCC0$,
 $V_{CC_USBA} = AVCC_USBA = 3.0$ to 3.6 V,
 $V_{SS} = AVSS0 = AVSS1 = V_{REFL0} = V_{SS_USB} = V_{SS1_USBA} = V_{SS2_USBA} = PV_{SS_USBA} = AV_{SS_USBA} = 0$ V,
 $ICLK = 8$ to 240 MHz, $PCLKA = 8$ to 120 MHz, $PCLKB = BCLK = SDCLK = 8$ to 60 MHz, $T_a = T_{opr}$
Output load conditions: $V_{OH} = V_{CC} \times 0.5$, $V_{OL} = V_{CC} \times 0.5$, $C = 30$ pF
High-drive output is selected by the driving ability control register.

Item	Symbol	Min.	Max.	Unit	Test Conditions
Address delay time	t_{AD}	—	12.5	ns	Figure 5.16 to Figure 5.21
Byte control delay time	t_{BCD}	—	12.5	ns	
CS# delay time	t_{CSD}	—	12.5	ns	
ALE delay time	t_{ALED}	—	12.5	ns	
RD# delay time	t_{RSD}	—	12.5	ns	
Read data setup time	t_{RDS}	12.5	—	ns	
Read data hold time	t_{RDH}	0	—	ns	
WR# delay time	t_{WRD}	—	12.5	ns	
Write data delay time	t_{WDD}	—	12.5	ns	
Write data hold time	t_{WDH}	0	—	ns	
WAIT# setup time	t_{WTS}	12.5	—	ns	
WAIT# hold time	t_{WTH}	0	—	ns	
Address delay time 2 (SDRAM)	t_{AD2}	1	12.5	ns	Figure 5.23
CS# delay time 2 (SDRAM)	t_{CSD2}	1	12.5	ns	
DQM delay time (SDRAM)	t_{DQMD}	1	12.5	ns	
CKE delay time (SDRAM)	t_{CKED}	1	12.5	ns	
Read data setup time 2 (SDRAM)	t_{RDS2}	10	—	ns	
Read data hold time 2 (SDRAM)	t_{RDH2}	0	—	ns	
Write data delay time 2 (SDRAM)	t_{WDD2}	—	12.5	ns	
Write data hold time 2 (SDRAM)	t_{WDH2}	1	—	ns	
WE# delay time (SDRAM)	t_{WED}	1	12.5	ns	
RAS# delay time (SDRAM)	t_{RASD}	1	12.5	ns	
CAS# delay time (SDRAM)	t_{CASD}	1	12.5	ns	



Figure 5.16 Address/Data Multiplexed Bus Read Access Timing



Figure 5.17 Address/Data Multiplexed Bus Write Access Timing



Figure 5.18 External Bus Timing/Normal Read Cycle (Bus Clock Synchronized)

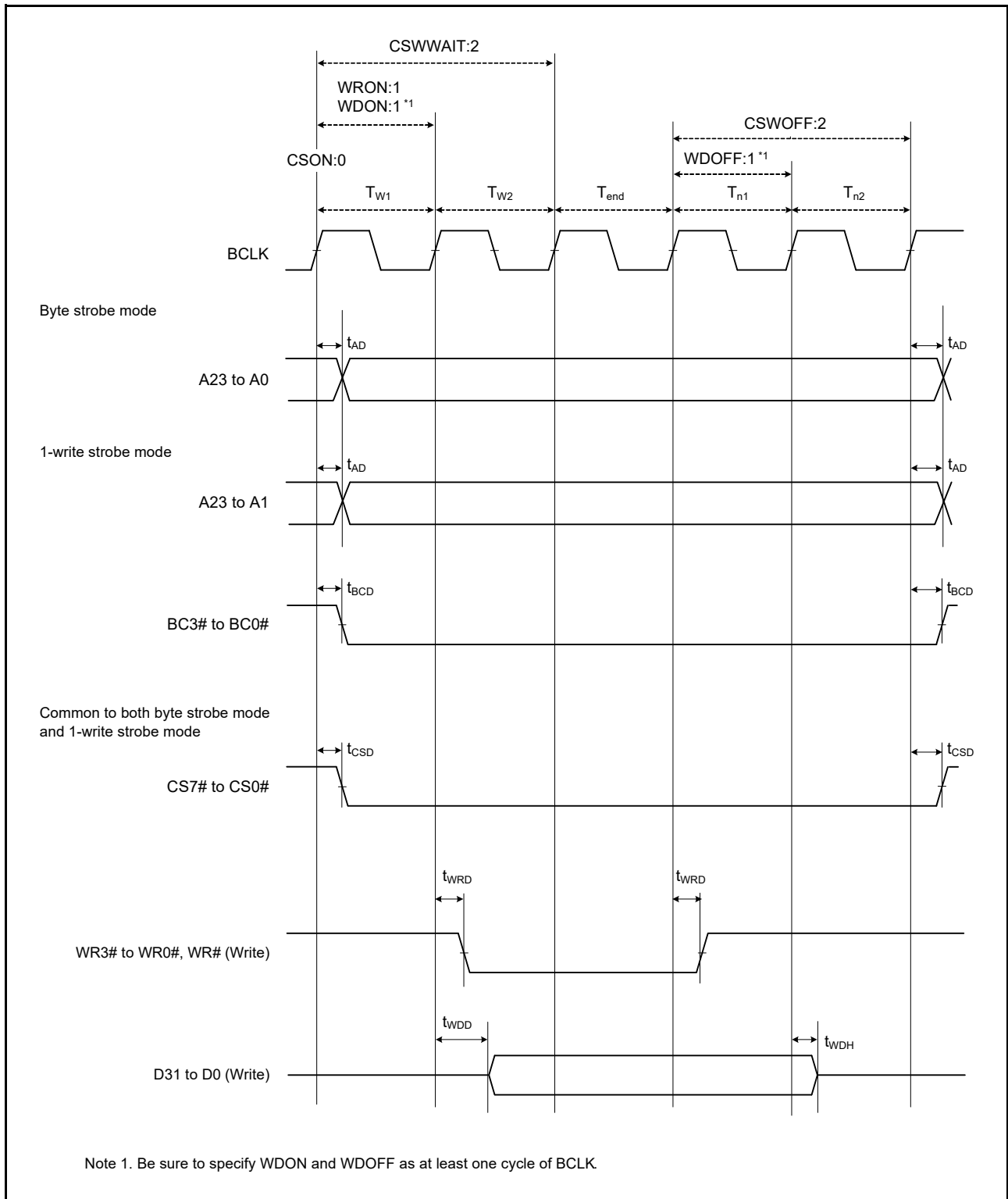

Figure 5.19 External Bus Timing/Normal Write Cycle (Bus Clock Synchronized)



Figure 5.20 External Bus Timing/Page Read Cycle (Bus Clock Synchronized)



Figure 5.21 External Bus Timing/Page Write Cycle (Bus Clock Synchronized)



Figure 5.22 External Bus Timing/External Wait Control



Figure 5.23 SDRAM Space Single Read Bus Timing



Figure 5.24 SDRAM Space Single Write Bus Timing



Figure 5.25 SDRAM Space Multiple Read Bus Timing

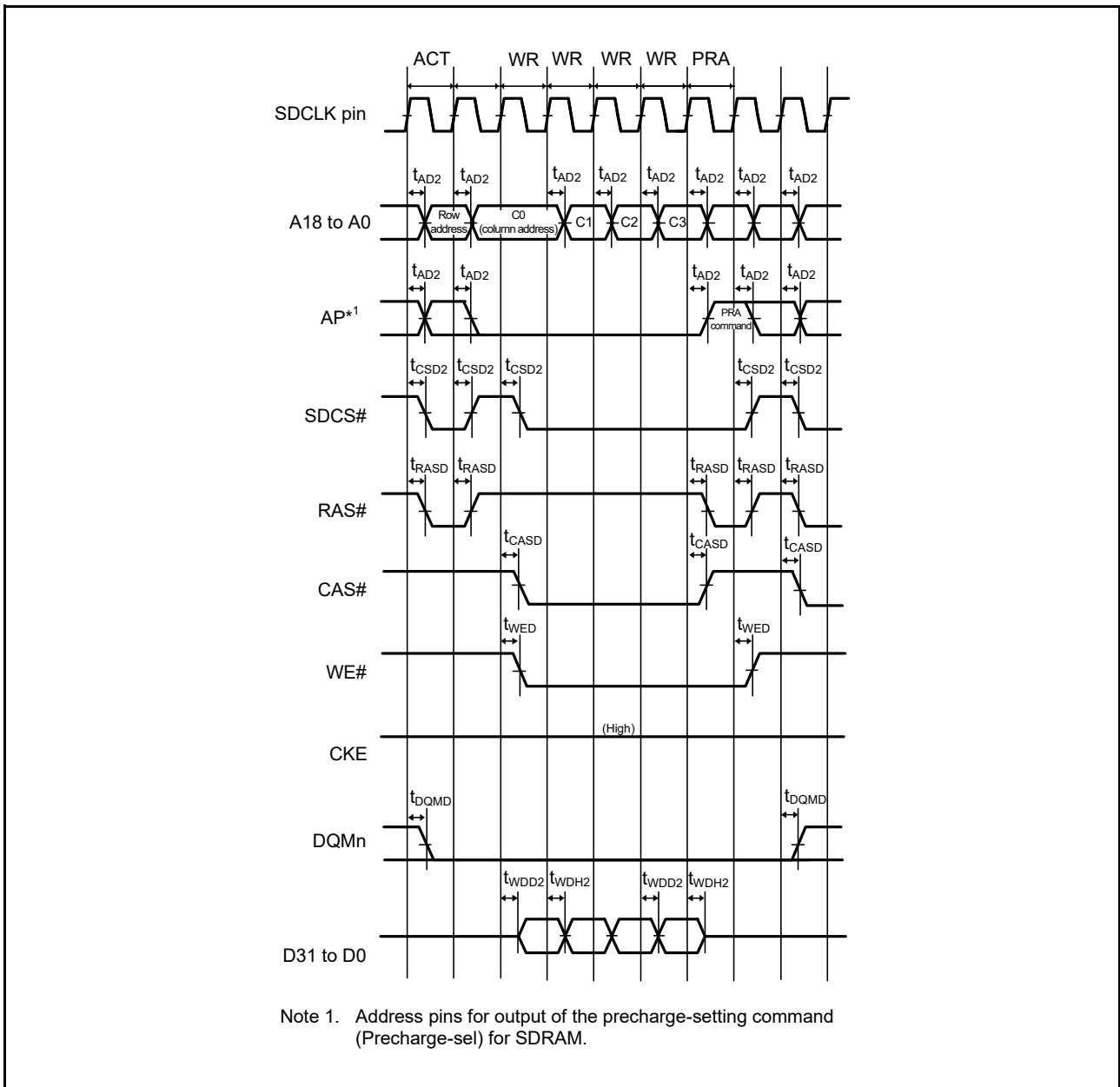

Figure 5.26 SDRAM Space Multiple Write Bus Timing



Figure 5.27 SDRAM Space Multiple Read Line Stride Bus Timing



Figure 5.28 SDRAM Space Mode Register Set Bus Timing



Figure 5.29 SDRAM Space Self-Refresh Bus Timing

5.3.6 EXDMAC Timing

Table 5.24 EXDMAC Timing

Conditions: $V_{CC} = AV_{CC0} = AV_{CC1} = V_{CC_USB} = V_{BATT} = 2.7$ to 3.6 V, $2.7 \leq V_{REFH0} \leq AV_{CC0}$,
 $V_{CC_USBA} = AV_{CC_USBA} = 3.0$ to 3.6 V,
 $V_{SS} = AV_{SS0} = AV_{SS1} = V_{REFL0} = V_{SS_USB} = V_{SS1_USBA} = V_{SS2_USBA} = PV_{SS_USBA} = AV_{SS_USBA} = 0$ V,
 $ICLK = 8$ to 240 MHz, $PCLKA = 8$ to 120 MHz, $PCLKB = BCLK = SDCLK = 8$ to 60 MHz, $T_a = T_{opr}$
 Output load conditions: $V_{OH} = V_{CC} \times 0.5$, $V_{OL} = V_{CC} \times 0.5$, $C = 30$ pF
 High-drive output is selected by the driving ability control register.

	Item	Symbol	Min.	Max.	Unit	Test Conditions
EXDMAC	EDREQ setup time	t_{EDRQS}	13	—	ns	Figure 5.30
	EDREQ hold time	t_{EDRQH}	2	—	ns	
	EDACK delay time	t_{EDACD}	—	13	ns	Figure 5.31, Figure 5.32



Figure 5.30 EDREQ0 and EDREQ1 Input Timing

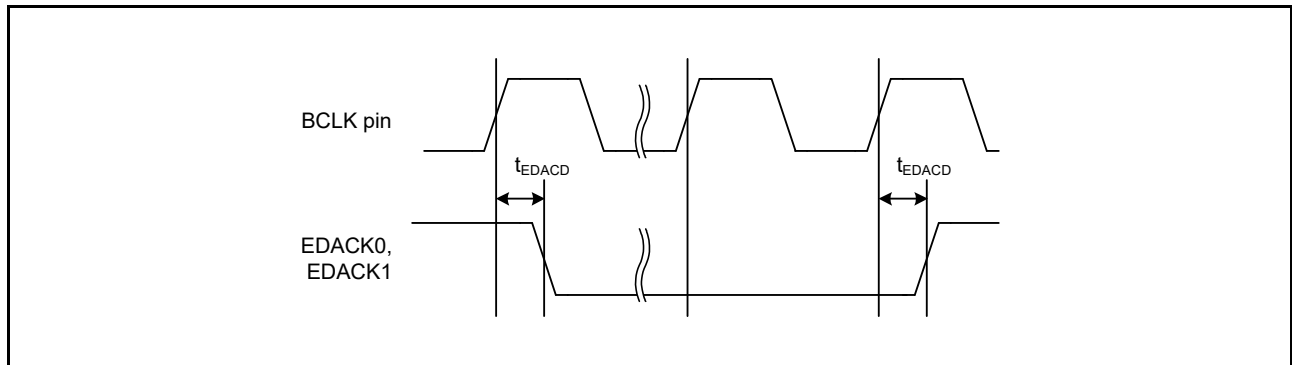

Figure 5.31 EDACK0 and EDACK1 Single-Address Transfer Timing (for a CS Area)



Figure 5.32 EDACK0 and EDACK1 Single-Address Transfer Timing (for SDRAM)

5.3.7 Timing of On-Chip Peripheral Modules

Table 5.25 I/O Port Timing

Conditions: $V_{CC} = AVCC0 = AVCC1 = V_{CC_USB} = V_{BATT} = 2.7$ to 3.6 V, $2.7 \leq V_{REFH0} \leq AVCC0$,
 $V_{CC_USBA} = AVCC_USBA = 3.0$ to 3.6 V,
 $V_{SS} = AVSS0 = AVSS1 = V_{REFL0} = V_{SS_USB} = V_{SS1_USBA} = V_{SS2_USBA} = PV_{SS_USBA} = AV_{SS_USBA} = 0$ V,
 $PCLKA = 8$ to 120 MHz, $PCLKB = 8$ to 60 MHz, $T_a = T_{opr}$
 Output load conditions: $V_{OH} = V_{CC} \times 0.5$, $V_{OL} = V_{CC} \times 0.5$, $C = 30$ pF
 High-drive output is selected by the driving ability control register.

Item		Symbol	Min.	Max.	Unit*1	Test Conditions
I/O ports	Input data pulse width	t_{PRW}	1.5	—	t_{PBcyc}	Figure 5.33

Note 1. t_{PBcyc} : PCLKB cycle



Figure 5.33 I/O Port Input Timing

Table 5.26 TPU Timing

Conditions: $V_{CC} = AVCC0 = AVCC1 = V_{CC_USB} = V_{BATT} = 2.7$ to 3.6 V, $2.7 \leq V_{REFH0} \leq AVCC0$,
 $V_{CC_USBA} = AVCC_USBA = 3.0$ to 3.6 V,
 $V_{SS} = AVSS0 = AVSS1 = V_{REFL0} = V_{SS_USB} = V_{SS1_USBA} = V_{SS2_USBA} = PVSS_USBA = AVSS_USBA = 0$ V,
 $PCLKA = 8$ to 120 MHz, $PCLKB = 8$ to 60 MHz, $T_a = T_{opr}$
 Output load conditions: $V_{OH} = V_{CC} \times 0.5$, $V_{OL} = V_{CC} \times 0.5$, $C = 30$ pF
 High-drive output is selected by the driving ability control register.

Item		Symbol	Min.	Max.	Unit*1	Test Conditions	
TPU	Input capture input pulse width	Single-edge setting	1.5	—	t_{PBcyc}	Figure 5.34	
		Both-edge setting	2.5	—			
	Timer clock pulse width	Single-edge setting	t_{TCKWH} , t_{TCKWL}	1.5	—	t_{PBcyc}	Figure 5.35
		Both-edge setting		2.5	—		
		Phase counting mode		2.5	—		

Note 1. t_{PBcyc} : PCLKB cycle

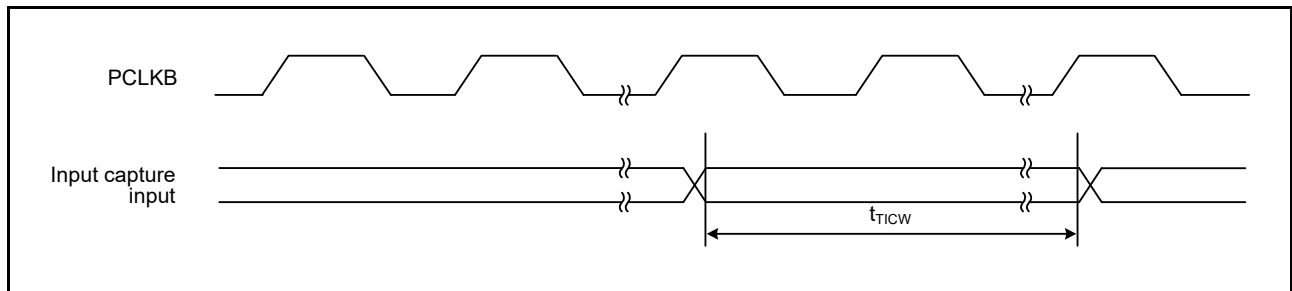

Figure 5.34 TPU Input Capture Input Timing



Figure 5.35 TPU Clock Input Timing

Table 5.27 TMR Timing

Conditions: $V_{CC} = AVCC0 = AVCC1 = V_{CC_USB} = V_{BATT} = 2.7$ to 3.6 V, $2.7 \leq V_{REFH0} \leq AVCC0$,
 $V_{CC_USBA} = AVCC_USBA = 3.0$ to 3.6 V,
 $V_{SS} = AVSS0 = AVSS1 = V_{REFL0} = V_{SS_USB} = V_{SS1_USBA} = V_{SS2_USBA} = PV_{SS_USBA} = AV_{SS_USBA} = 0$ V,
 $PCLKA = 8$ to 120 MHz, $PCLKB = 8$ to 60 MHz, $T_a = T_{opr}$
 Output load conditions: $V_{OH} = V_{CC} \times 0.5$, $V_{OL} = V_{CC} \times 0.5$, $C = 30$ pF
 High-drive output is selected by the driving ability control register.

Item		Symbol	Min.	Max.	Unit*1	Test Conditions
TMR	Timer clock pulse width	Single-edge setting	1.5	—	t_{PBcyc}	Figure 5.36
		Both-edge setting	2.5	—		

Note 1. t_{PBcyc} : PCLKB cycle

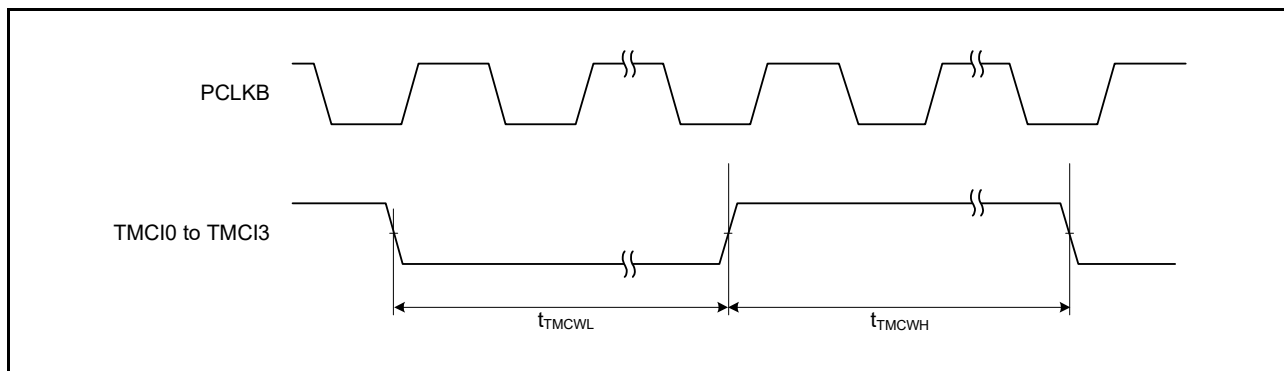

Figure 5.36 TMR Clock Input Timing

Table 5.28 CMTW Timing

Conditions: $V_{CC} = AVCC0 = AVCC1 = V_{CC_USB} = V_{BATT} = 2.7$ to 3.6 V, $2.7 \leq V_{REFH0} \leq AVCC0$,
 $V_{CC_USBA} = AVCC_USBA = 3.0$ to 3.6 V,
 $V_{SS} = AVSS0 = AVSS1 = V_{REFL0} = V_{SS_USB} = V_{SS1_USBA} = V_{SS2_USBA} = PV_{SS_USBA} = AV_{SS_USBA} = 0$ V,
 $PCLKA = 8$ to 120 MHz, $PCLKB = 8$ to 60 MHz, $T_a = T_{opr}$
 Output load conditions: $V_{OH} = V_{CC} \times 0.5$, $V_{OL} = V_{CC} \times 0.5$, $C = 30$ pF
 High-drive output is selected by the driving ability control register.

Item		Symbol	Min.	Max.	Unit*1	Test Conditions
CMTW	Input capture input pulse width	Single-edge setting	1.5	—	t_{PBcyc}	Figure 5.37
		Both-edge setting	2.5	—		

Note 1. t_{PBcyc} : PCLKB cycle

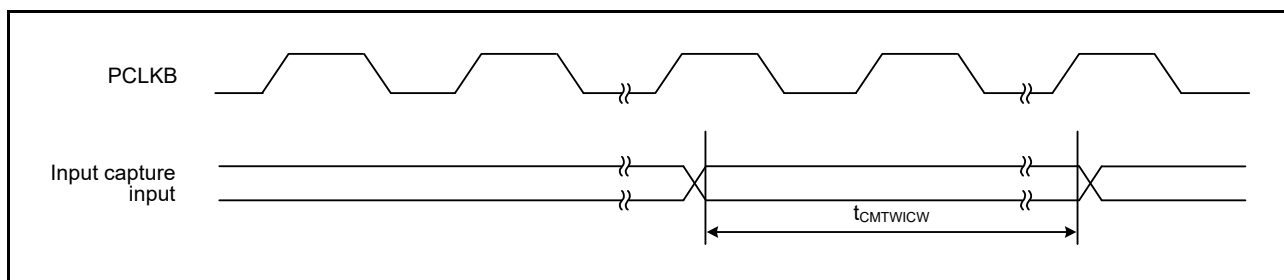

Figure 5.37 CMTW Input Capture Input Timing

Table 5.29 MTU3 Timing

Conditions: $V_{CC} = AVCC0 = AVCC1 = V_{CC_USB} = V_{BATT} = 2.7$ to 3.6 V, $2.7 \leq V_{REFH0} \leq AVCC0$,
 $V_{CC_USBA} = AVCC_USBA = 3.0$ to 3.6 V,
 $V_{SS} = AVSS0 = AVSS1 = V_{REFL0} = V_{SS_USB} = V_{SS1_USBA} = V_{SS2_USBA} = PVSS_USBA = AVSS_USBA = 0$ V,
 $PCLKA = 8$ to 120 MHz, $PCLKB = 8$ to 60 MHz, $T_a = T_{opr}$
 Output load conditions: $V_{OH} = V_{CC} \times 0.5$, $V_{OL} = V_{CC} \times 0.5$, $C = 30$ pF
 High-drive output is selected by the driving ability control register.

Item		Symbol	Min.	Max.	Unit*1	Test Conditions	
MTU3	Input capture input pulse width	Single-edge setting	1.5	—	t_{PAcyc}	Figure 5.38	
		Both-edge setting	2.5	—			
	Timer clock pulse width	Single-edge setting	t_{MTCKWH} , t_{MTCKWL}	1.5	—	t_{PAcyc}	Figure 5.39
		Both-edge setting		2.5	—		
		Phase counting mode		2.5	—		

Note 1. t_{PAcyc} : PCLKA cycle



Figure 5.38 MTU3 Input Capture Input Timing



Figure 5.39 MTU3 Clock Input Timing

Table 5.30 POE3 Timing

Conditions: $V_{CC} = AVCC0 = AVCC1 = V_{CC_USB} = V_{BATT} = 2.7$ to 3.6 V, $2.7 \leq V_{REFH0} \leq AVCC0$,
 $V_{CC_USBA} = AVCC_USBA = 3.0$ to 3.6 V,
 $V_{SS} = AVSS0 = AVSS1 = V_{REFL0} = V_{SS_USB} = V_{SS1_USBA} = V_{SS2_USBA} = PV_{SS_USBA} = AV_{SS_USBA} = 0$ V,
 $PCLKA = 8$ to 120 MHz, $PCLKB = 8$ to 60 MHz, $T_a = T_{opr}$
 Output load conditions: $V_{OH} = V_{CC} \times 0.5$, $V_{OL} = V_{CC} \times 0.5$, $C = 30$ pF
 High-drive output is selected by the driving ability control register.

Item		Symbol	Min.	Max.	Unit*1	Test Conditions
POE	POE# input pulse width	t_{POEW}	1.5	—	t_{PBcyc}	Figure 5.40

Note 1. t_{PBcyc} : PCLKB cycle



Figure 5.40 POE# Input Timing

Table 5.31 GPT Timing

Conditions: $V_{CC} = AVCC0 = AVCC1 = V_{CC_USB} = V_{BATT} = 2.7$ to 3.6 V, $2.7 \leq V_{REFH0} \leq AVCC0$,
 $V_{CC_USBA} = AVCC_USBA = 3.0$ to 3.6 V,
 $V_{SS} = AVSS0 = AVSS1 = V_{REFL0} = V_{SS_USB} = V_{SS1_USBA} = V_{SS2_USBA} = PVSS_USBA = AVSS_USBA = 0$ V,
 $PCLKA = 8$ to 120 MHz, $PCLKB = 8$ to 60 MHz, $T_a = T_{opr}$
 Output load conditions: $V_{OH} = V_{CC} \times 0.5$, $V_{OL} = V_{CC} \times 0.5$, $C = 30$ pF
 High-drive output is selected by the driving ability control register.

Item		Symbol	Min.	Max.	Unit*1	Test Conditions
GPT	Input capture input pulse width	Single-edge setting	3	—	t_{PACyc}	Figure 5.41
		Both-edge setting	5	—		
	External trigger input pulse width	Single-edge setting	1.5	—	t_{PACyc}	
		Both-edge setting	2.5	—		

Note 1. t_{PACyc} : PCLKA cycle



Figure 5.41 GPT Input Capture Input Timing

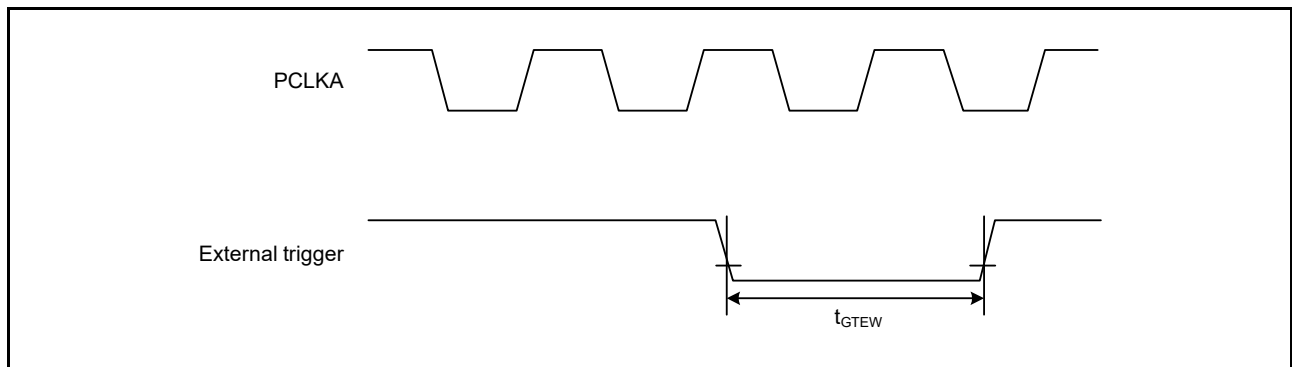

Figure 5.42 GPT External Trigger Input Timing

Table 5.32 A/D Converter Trigger Timing

Conditions: $V_{CC} = AVCC0 = AVCC1 = V_{CC_USB} = V_{BATT} = 2.7$ to 3.6 V, $2.7 \leq V_{REFH0} \leq AVCC0$,
 $V_{CC_USBA} = AVCC_USBA = 3.0$ to 3.6 V,
 $V_{SS} = AVSS0 = AVSS1 = V_{REFL0} = V_{SS_USB} = V_{SS1_USBA} = V_{SS2_USBA} = PV_{SS_USBA} = AVSS_USBA = 0$ V,
 $PCLKA = 8$ to 120 MHz, $PCLKB = 8$ to 60 MHz, $T_a = T_{opr}$
 Output load conditions: $V_{OH} = V_{CC} \times 0.5$, $V_{OL} = V_{CC} \times 0.5$, $C = 30$ pF
 High-drive output is selected by the driving ability control register.

Item		Symbol	Min.	Max.	Unit*1	Test Conditions
A/D converter	A/D converter trigger input pulse width	t_{TRGW}	1.5	—	t_{PBcyc}	Figure 5.43

Note 1. t_{PBcyc} : PCLKB cycle

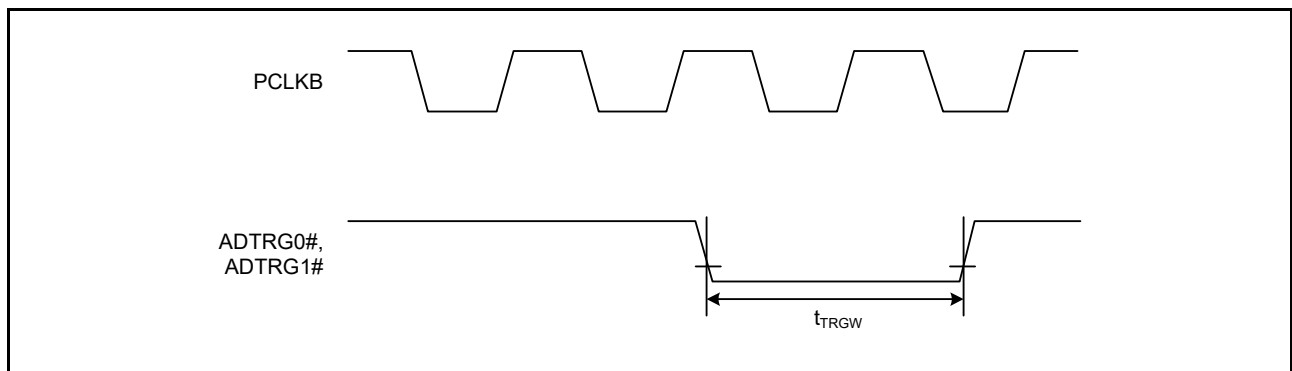

Figure 5.43 A/D Converter Trigger Input Timing

Table 5.33 CAC Timing

Conditions: $V_{CC} = AVCC0 = AVCC1 = V_{CC_USB} = V_{BATT} = 2.7$ to 3.6 V, $2.7 \leq V_{REFH0} \leq AVCC0$,
 $V_{CC_USBA} = AVCC_USBA = 3.0$ to 3.6 V,
 $V_{SS} = AVSS0 = AVSS1 = V_{REFL0} = V_{SS_USB} = V_{SS1_USBA} = V_{SS2_USBA} = PV_{SS_USBA} = AVSS_USBA = 0$ V,
 $PCLKA = 8$ to 120 MHz, $PCLKB = 8$ to 60 MHz, $T_a = T_{opr}$
 Output load conditions: $V_{OH} = V_{CC} \times 0.5$, $V_{OL} = V_{CC} \times 0.5$, $C = 30$ pF
 High-drive output is selected by the driving ability control register.

Item*1, *2		Symbol	Min.*1	Max.	Unit*1	Test Conditions
CAC	CACREF input pulse width	t_{CACREF}	$t_{PBcyc} \leq t_{cac}$	$4.5 t_{cac} + 3 t_{PBcyc}$	—	ns
			$t_{PBcyc} > t_{cac}$	$5 t_{cac} + 6.5 t_{PBcyc}$	—	

Note 1. t_{PBcyc} : PCLKB cycle

Note 2. t_{CAC} : CAC count clock source cycle

Table 5.34 SCI and SCIF Timing

Conditions: $V_{CC} = AVCC0 = AVCC1 = V_{CC_USB} = V_{BATT} = 2.7$ to 3.6 V, $2.7 \leq V_{REFH0} \leq AVCC0$,
 $V_{CC_USBA} = AVCC_USBA = 3.0$ to 3.6 V,
 $V_{SS} = AVSS0 = AVSS1 = V_{REFL0} = V_{SS_USB} = V_{SS1_USBA} = V_{SS2_USBA} = PVSS_USBA = AVSS_USBA = 0$ V,
 $PCLKA = 8$ to 120 MHz, $PCLKB = 8$ to 60 MHz, $T_a = T_{opr}$
Output load conditions: $V_{OH} = V_{CC} \times 0.5$, $V_{OL} = V_{CC} \times 0.5$, $C = 30$ pF
High-drive output is selected by the driving ability control register.

Item		Symbol	Min.*1	Max.*1	Unit*1	Test Conditions		
SCI	Input clock cycle	Asynchronous	t_{Scyc}	4	—	t_{PBcyc}	Figure 5.44	
		Clock synchronous		6	—			
	Input clock pulse width		t_{SCKW}	0.4	0.6	t_{Scyc}		
	Input clock rise time		t_{SCKr}	—	5	ns		
	Input clock fall time		t_{SCKf}	—	5	ns		
	Output clock cycle	Asynchronous*2	t_{Scyc}	8	—	t_{PBcyc}		
		Clock synchronous		4	—			
	Output clock pulse width		t_{SCKW}	0.4	0.6	t_{Scyc}		
	Output clock rise time		t_{SCKr}	—	5	ns		
	Output clock fall time		t_{SCKf}	—	5	ns		
	Transmit data delay time	Clock synchronous	t_{TXD}	—	28	ns		Figure 5.45
	Receive data setup time	Clock synchronous	t_{RXS}	15	—	ns		
Receive data hold time	Clock synchronous	t_{RXH}	5	—	ns			
SCIF	Input clock cycle	Asynchronous	t_{Scyc}	4	—	t_{PAcyc}	Figure 5.44	
		Clock synchronous		12	—			
	Input clock pulse width		t_{SCKW}	0.4	0.6	t_{Scyc}		
	Input clock rise time		t_{SCKr}	—	5	ns		
	Input clock fall time		t_{SCKf}	—	5	ns		
	Output clock cycle	Asynchronous*3	t_{Scyc}	8	—	t_{PAcyc}		
		Clock synchronous		4	—			
	Output clock pulse width		t_{SCKW}	0.4	0.6	t_{Scyc}		
	Output clock rise time		t_{SCKr}	—	5	ns		
	Output clock fall time		t_{SCKf}	—	5	ns		
	Transmit data delay time	Master	t_{TXD}	—	10	ns		Figure 5.45
		Slave		—	$4 \times t_{PAcyc} + 20$			
Receive data setup time	Master	t_{RXS}	$3 \times t_{PAcyc} + 20$	—	ns			
	Slave		$t_{PAcyc} + 10$	—				
Receive data hold time	Master	t_{RXH}	$-3 \times t_{PAcyc} + 5$	—	ns			
	Slave		$2 \times t_{PAcyc} + 10$	—				

Note 1. t_{PBcyc} : PCLKB cycle; t_{PAcyc} : PCLKA cycle

Note 2. When the SEMR.ABCS and SEMR.BGDM bits are set to 1

Note 3. When the SEMR.ABCS0 and SEMR.BGDM bits are set to 1



Figure 5.44 SCK Clock Input Timing



Figure 5.45 SCI Input/Output Timing: Clock Synchronous Mode

Table 5.35 RSPI Timing

Conditions: $V_{CC} = AVCC0 = AVCC1 = V_{CC_USB} = V_{BATT} = 2.7$ to 3.6 V, $2.7 \leq V_{REFH0} \leq AVCC0$,
 $V_{CC_USBA} = AVCC_USBA = 3.0$ to 3.6 V,
 $V_{SS} = AVSS0 = AVSS1 = V_{REFL0} = V_{SS_USB} = V_{SS1_USBA} = V_{SS2_USBA} = PVSS_USBA = AVSS_USBA = 0$ V,
 $PCLKA = 8$ to 120 MHz, $PCLKB = 8$ to 60 MHz, $T_a = T_{opr}$
 Output load conditions: $V_{OH} = V_{CC} \times 0.5$, $V_{OL} = V_{CC} \times 0.5$, $C = 30$ pF
 High-drive output is selected by the driving ability control register.

Item		Symbol	Min.*1	Max.*1	Unit*1	Test Conditions*2	
RSPI	RSPCK clock cycle	Master	t_{SPcyc}	2	4096	t_{PAcyc}	Figure 5.46
		Slave		8	4096		
	RSPCK clock high pulse width	Master	t_{SPCKWH}	$(t_{SPcyc} - t_{SPCKR} - t_{SPCKF}) / 2 - 3$	—	ns	
		Slave		$(t_{SPcyc} - t_{SPCKR} - t_{SPCKF}) / 2$	—		
	RSPCK clock low pulse width	Master	t_{SPCKWL}	$(t_{SPcyc} - t_{SPCKR} - t_{SPCKF}) / 2 - 3$	—	ns	
		Slave		$(t_{SPcyc} - t_{SPCKR} - t_{SPCKF}) / 2$	—		
	RSPCK clock rise/fall time	Output	t_{SPCKr}	—	5	ns	
		Input	t_{SPCKf}	—	1	μ s	
	Data input setup time	Master	t_{SU}	6	—	ns	Figure 5.47 to Figure 5.52
		Slave		$8.3 - t_{PAcyc}$	—		
	Data input hold time	Master	PCLKA division ratio set to 1/2	t_{HF}	0	—	ns
			PCLKA division ratio set to a value other than 1/2	t_H	t_{PAcyc}	—	
		Slave		$8.3 + 2 \times t_{PAcyc}$	—		
	SSL setup time	Master	t_{LEAD}	1	8	t_{SPcyc}	
		Slave		4	—	t_{PAcyc}	
	SSL hold time	Master	t_{LAG}	1	8	t_{SPcyc}	
		Slave		4	—	t_{PAcyc}	
	Data output delay time	Master	t_{OD}	—	6.3	ns	
		Slave		—	$3 \times t_{PAcyc} + 20$		
	Data output hold time	Master	t_{OH}	0	—	ns	
		Slave		0	—		
	Successive transmission delay time	Master	t_{TD}	$t_{SPcyc} + 2 \times t_{PAcyc}$	$8 \times t_{SPcyc} + 2 \times t_{PAcyc}$	ns	
		Slave		$4 \times t_{PAcyc}$	—		
	MOSI and MISO rise/fall time	Output	t_{Dr}, t_{Df}	—	5	ns	
		Input		—	1		
	SSL rise/fall time	Output	t_{SSLr}, t_{SSLf}	—	5	ns	
		Input		—	1		
	Slave access time		t_{SA}	—	4	t_{PAcyc}	Figure 5.51, Figure 5.52
	Slave output release time		t_{REL}	—	3	t_{PAcyc}	

Note 1. t_{PAcyc} : PCLKA cycle

Note 2. We recommend using pins that have a letter ("A", "B", etc.) to indicate group membership appended to their names as groups. For the RSPI interface, the AC portion of the electrical characteristics is measured for each group.

Table 5.36 Simple SPI Timing

Conditions: $V_{CC} = AV_{CC0} = AV_{CC1} = V_{CC_USB} = V_{BATT} = 2.7$ to 3.6 V, $2.7 \leq V_{REFH0} \leq AV_{CC0}$,
 $V_{CC_USBA} = AV_{CC_USBA} = 3.0$ to 3.6 V,
 $V_{SS} = AV_{SS0} = AV_{SS1} = V_{REFL0} = V_{SS_USB} = V_{SS1_USBA} = V_{SS2_USBA} = PV_{SS_USBA} = AV_{SS_USBA} = 0$ V,
 $PCLKA = 8$ to 120 MHz, $PCLKB = 8$ to 60 MHz, $T_a = T_{opr}$
 Output load conditions: $V_{OH} = V_{CC} \times 0.5$, $V_{OL} = V_{CC} \times 0.5$, $C = 30$ pF
 High-drive output is selected by the driving ability control register.

Item		Symbol	Min.	Max.	Unit*1	Test Conditions
Simple SPI	SCK clock cycle output (master)	t_{SPcyc}	4	65536	t_{PBcyc}	Figure 5.46 Figure 5.47 to Figure 5.52 Figure 5.51, Figure 5.52
	SCK clock cycle input (slave)		8	65536		
	SCK clock high pulse width	t_{SPCKWH}	0.4	0.6	t_{SPcyc}	
	SCK clock low pulse width	t_{SPCKWL}	0.4	0.6	t_{SPcyc}	
	SCK clock rise/fall time	t_{SPCKr} , t_{SPCKf}	—	20	ns	
	Data input setup time	t_{SU}	33.3	—	ns	
	Data input hold time	t_H	33.3	—	ns	
	SS input setup time	t_{LEAD}	1	—	t_{SPcyc}	
	SS input hold time	t_{LAG}	1	—	t_{SPcyc}	
	Data output delay time	t_{OD}	—	33.3	ns	
	Data output hold time	t_{OH}	-10	—	ns	
	Data rise/fall time	t_{Dr} , t_{Df}	—	16.6	ns	
	SS input rise/fall time	t_{SSLr} , t_{SSLf}	—	16.6	ns	
	Slave access time	t_{SA}	—	5	t_{PBcyc}	
	Slave output release time	t_{REL}	—	5	t_{PBcyc}	

Note 1. t_{PBcyc} : PCLKB cycle



Figure 5.46 RSPI Clock Timing and Simple SPI Clock Timing



Figure 5.47 RSPI Timing (Master, CPHA = 0) (Bit Rate: PCLKA Division Ratio Set to a Value Other Than 1/2) and Simple SPI Timing (Master, CKPH = 1)



Figure 5.48 RSPI Timing (Master, CPHA = 0) (Bit Rate: PCLKA Division Ratio Set to 1/2)



Figure 5.49 RSPI Timing (Master, CPHA = 1) (Bit Rate: PCLKA Division Ratio Set to a Value Other Than 1/2) and Simple SPI Timing (Master, CKPH = 0)



Figure 5.50 RSPI Timing (Master, CPHA = 1) (Bit Rate: PCLKA Division Ratio Set to 1/2)

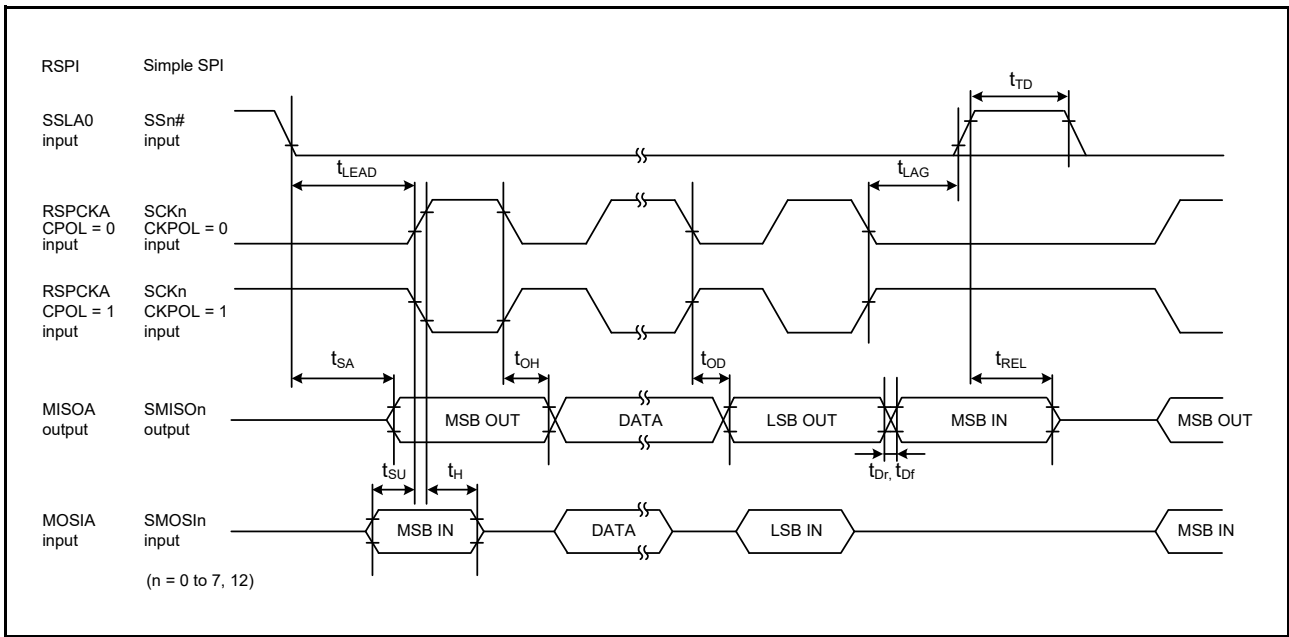

Figure 5.51 RSPI Timing (Slave, CPHA = 0) and Simple SPI Timing (Slave, CKPH = 1)

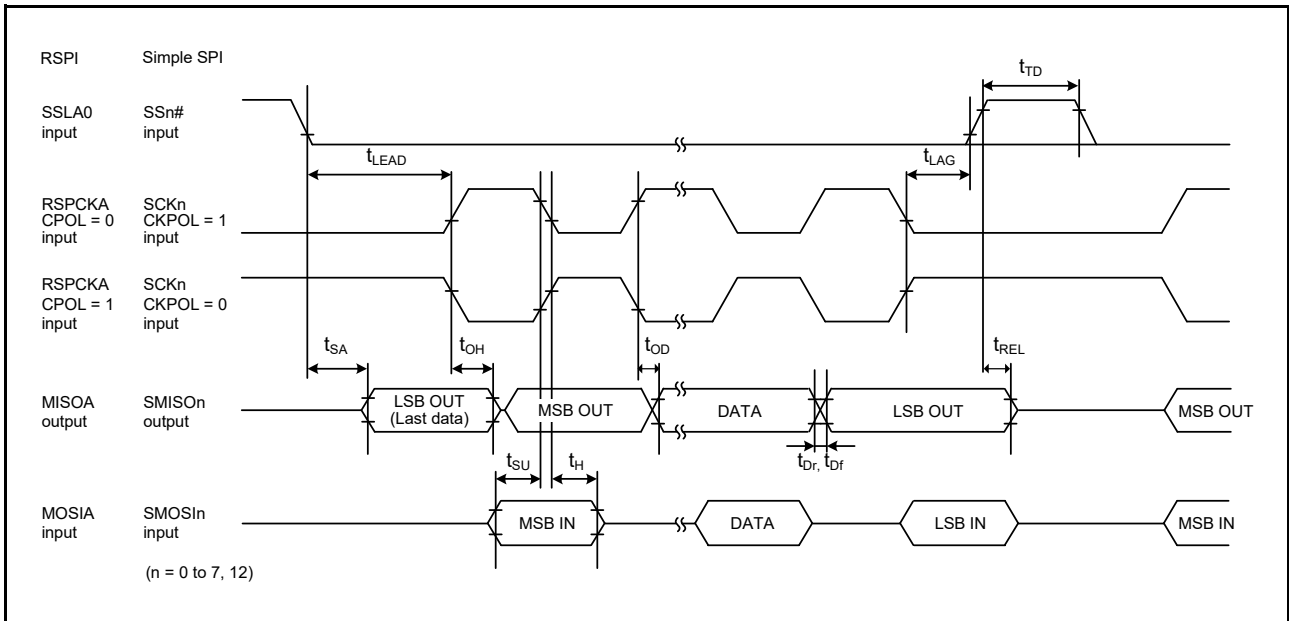

Figure 5.52 RSPI Timing (Slave, CPHA = 1) and Simple SPI Timing (Slave, CKPH = 0)

Table 5.37 QSPI Timing

Conditions: $V_{CC} = AV_{CC0} = AV_{CC1} = V_{CC_USB} = V_{BATT} = 2.7$ to 3.6 V, $2.7 \leq V_{REFH0} \leq AV_{CC0}$,
 $V_{CC_USBA} = AV_{CC_USBA} = 3.0$ to 3.6 V,
 $V_{SS} = AV_{SS0} = AV_{SS1} = V_{REFL0} = V_{SS_USB} = V_{SS1_USBA} = V_{SS2_USBA} = PV_{SS_USBA} = AV_{SS_USBA} = 0$ V,
 $PCLKA = 8$ to 120 MHz, $PCLKB = 8$ to 60 MHz, $T_a = T_{opr}$
 Output load conditions: $V_{OH} = V_{CC} \times 0.5$, $V_{OL} = V_{CC} \times 0.5$, $C = 30$ pF
 High-drive output is selected by the driving ability control register.

Item	Symbol	Min.	Max.	Unit*1	Test Conditions*2	
QSPI	QSPCLK clock cycle	t_{QScyc}	2	4080	t_{PBcyc}	Figure 5.53
	Data input setup time	t_{Su}	6.5	—	ns	Figure 5.54, Figure 5.55
	Data input hold time	t_{IH}	5	—	ns	
	SS setup time	t_{LEAD}	1.5	8.5	t_{QScyc}	
	SS hold time	t_{LAG}	1	8	t_{QScyc}	
	Data output delay time	t_{OD}	—	10.0	ns	
	Data output hold time	t_{OH}	-5	—	ns	
	Successive transmission delay time	t_{TD}	1	8	t_{QScyc}	

Note 1. t_{PBcyc} : PCLKB cycle

Note 2. We recommend using pins that have a letter (“-A”, “-B”, etc.) to indicate group membership appended to their names as groups. For the QSPI interface, the AC portion of the electrical characteristics is measured for each group.



Figure 5.53 QSPI Clock Timing



Figure 5.54 Transmit/Receive Timing (CPHA = 0)



Figure 5.55 Transmit/Receive Timing (CPHA = 1)

Table 5.38 RIIC Timing (1)

Conditions: $VCC = AVCC0 = AVCC1 = VCC_USB = V_{BATT} = 2.7$ to 3.6 V, $2.7 \leq VREFH0 \leq AVCC0$,
 $VCC_USBA = AVCC_USBA = 3.0$ to 3.6 V,
 $VSS = AVSS0 = AVSS1 = VREFL0 = VSS_USB = VSS1_USBA = VSS2_USBA = PVSS_USBA = AVSS_USBA = 0$ V,
 $PCLKA = 8$ to 120 MHz, $PCLKB = 8$ to 60 MHz, $T_a = T_{opr}$
 High-drive output is selected by the driving ability control register.

Item		Symbol	Min.*1, *2	Max.	Unit	Test Conditions
RIIC (Standard-mode, SMBus) ICFER.FMPE = 0	SCL input cycle time	t_{SCL}	$6(12) \times t_{IICcyc} + 1300$	—	ns	Figure 5.56
	SCL input high pulse width	t_{SCLH}	$3(6) \times t_{IICcyc} + 300$	—	ns	
	SCL input low pulse width	t_{SCLL}	$3(6) \times t_{IICcyc} + 300$	—	ns	
	SCL, SDA input rise time	t_{Sr}	—	1000	ns	
	SCL, SDA input fall time	t_{Sf}	—	300	ns	
	SCL, SDA input spike pulse removal time	t_{SP}	0	$1(4) \times t_{IICcyc}$	ns	
	SDA input bus free time	t_{BUF}	$3(6) \times t_{IICcyc} + 300$	—	ns	
	Start condition input hold time	t_{STAH}	$t_{IICcyc} + 300$	—	ns	
	Restart condition input setup time	t_{STAS}	1000	—	ns	
	Stop condition input setup time	t_{STOS}	1000	—	ns	
	Data input setup time	t_{SDAS}	$t_{IICcyc} + 50$	—	ns	
	Data input hold time	t_{SDAH}	0	—	ns	
	SCL, SDA capacitive load	C_b	—	400	pF	
RIIC (Fast-mode) ICFER.FMPE = 0	SCL input cycle time	t_{SCL}	$6(12) \times t_{IICcyc} + 600$	—	ns	
	SCL input high pulse width	t_{SCLH}	$3(6) \times t_{IICcyc} + 300$	—	ns	
	SCL input low pulse width	t_{SCLL}	$3(6) \times t_{IICcyc} + 300$	—	ns	
	SCL, SDA input rise time	t_{Sr}	$20 \times (\text{External pull-up voltage} / 5.5 \text{ V})$	300	ns	
	SCL, SDA input fall time	t_{Sf}	$20 \times (\text{External pull-up voltage} / 5.5 \text{ V})$	300	ns	
	SCL, SDA input spike pulse removal time	t_{SP}	0	$1(4) \times t_{IICcyc}$	ns	
	SDA input bus free time	t_{BUF}	$3(6) \times t_{IICcyc} + 300$	—	ns	
	Start condition input hold time	t_{STAH}	$t_{IICcyc} + 300$	—	ns	
	Restart condition input setup time	t_{STAS}	300	—	ns	
	Stop condition input setup time	t_{STOS}	300	—	ns	
	Data input setup time	t_{SDAS}	$t_{IICcyc} + 50$	—	ns	
	Data input hold time	t_{SDAH}	0	—	ns	
	SCL, SDA capacitive load	C_b	—	400	pF	

Note: t_{IICcyc} : RIIC internal reference clock (IIC ϕ) cycle

Note 1. The value within parentheses is applicable when the value of the ICMR3.NF[1:0] bits is 11b while the digital filter is enabled by the setting ICFER.NFE = 1.

Note 2. C_b is the total capacitance of the bus lines.

Table 5.39 RIIC Timing (2)

Conditions: $V_{CC} = AVCC0 = AVCC1 = V_{CC_USB} = V_{BATT} = 2.7$ to 3.6 V, $2.7 \leq V_{REFH0} \leq AVCC0$,
 $V_{CC_USBA} = AVCC_USBA = 3.0$ to 3.6 V,
 $V_{SS} = AVSS0 = AVSS1 = V_{REFL0} = V_{SS_USB} = V_{SS1_USBA} = V_{SS2_USBA} = PV_{SS_USBA} = AV_{SS_USBA} = 0$ V,
 $PCLKA = 8$ to 120 MHz, $PCLKB = 8$ to 60 MHz, $T_a = T_{opr}$
 High-drive output is selected by the driving ability control register.

Item		Symbol	Min.*1, *2	Max.	Unit	Test Conditions
RIIC (Fast-mode+) ICFER.FMPE = 1	SCL input cycle time	t_{SCL}	$6(12) \times t_{IICcyc} + 240$	—	ns	Figure 5.56
	SCL input high pulse width	t_{SCLH}	$3(6) \times t_{IICcyc} + 120$	—	ns	
	SCL input low pulse width	t_{SCLL}	$3(6) \times t_{IICcyc} + 120$	—	ns	
	SCL, SDA input rise time	t_{Sr}	—	120	ns	
	SCL, SDA input fall time	t_{Sf}	—	120	ns	
	SCL, SDA input spike pulse removal time	t_{SP}	0	$1(4) \times t_{IICcyc}$	ns	
	SDA input bus free time	t_{BUF}	$3(6) \times t_{IICcyc} + 120$	—	ns	
	Start condition input hold time	t_{STAH}	$t_{IICcyc} + 120$	—	ns	
	Restart condition input setup time	t_{STAS}	120	—	ns	
	Stop condition input setup time	t_{STOS}	120	—	ns	
	Data input setup time	t_{SDAS}	$t_{IICcyc} + 20$	—	ns	
	Data input hold time	t_{SDAH}	0	—	ns	
	SCL, SDA capacitive load	C_b	—	550	pF	
Simple IIC (Standard-mode)	SDA input rise time	t_{Sr}	—	1000	ns	
	SDA input fall time	t_{Sf}	—	300	ns	
	SDA input spike pulse removal time	t_{SP}	0	$4 \times t_{PBcyc}$	ns	
	Data input setup time	t_{SDAS}	250	—	ns	
	Data input hold time	t_{SDAH}	0	—	ns	
	SCL, SDA capacitive load	C_b	—	400	pF	
Simple IIC (Fast-mode)	SCL, SDA input rise time	t_{Sr}	—	300	ns	
	SCL, SDA input fall time	t_{Sf}	—	300	ns	
	SCL, SDA input spike pulse removal time	t_{SP}	0	$4 \times t_{PBcyc}$	ns	
	Data input setup time	t_{SDAS}	100	—	ns	
	Data input hold time	t_{SDAH}	0	—	ns	
	SCL, SDA capacitive load	C_b	—	400	pF	

Note: t_{IICcyc} : RIIC internal reference clock (IIC ϕ) cycle, t_{PBcyc} : PCLKB cycle

Note 1. The value within parentheses is applicable when the value of the ICMR3.NF[1:0] bits is 11b while the digital filter is enabled by the setting ICFER.NFE = 1.

Note 2. C_b is the total capacitance of the bus lines.



Figure 5.56 RIIC Bus Interface Input/Output Timing and Simple IIC Bus Interface Input/Output Timing

Table 5.40 Serial Sound Interface Timing

Conditions: $V_{CC} = AVCC0 = AVCC1 = V_{CC_USB} = V_{BATT} = 2.7$ to 3.6 V, $2.7 \leq V_{REFH0} \leq AVCC0$,
 $V_{CC_USBA} = AVCC_USBA = 3.0$ to 3.6 V,
 $V_{SS} = AVSS0 = AVSS1 = V_{REFL0} = V_{SS_USB} = V_{SS1_USBA} = V_{SS2_USBA} = PV_{SS_USBA} = AV_{SS_USBA} = 0$ V,
 $PCLKA = 8$ to 120 MHz, $PCLKB = 8$ to 60 MHz, $T_a = T_{opr}$
 Output load conditions: $V_{OH} = V_{CC} \times 0.5$, $V_{OL} = V_{CC} \times 0.5$, $C = 30$ pF
 High-drive output is selected by the driving ability control register.

Item	Symbol	Min.	Max.	Unit	Test Conditions
SSI	AUDIO_CLK input frequency	—	50	MHz	
	Output clock cycle	150	64000	ns	Figure 5.57
	Input clock cycle	150	64000	ns	
	Clock high level	60	—	ns	
	Clock low level	60	—	ns	
	Clock rising time	—	25	ns	
	Clock falling time	—	25	ns	
	Data delay time	-5	25	ns	Figure 5.58, Figure 5.59
	Setup time	25	—	ns	
	Hold time	25	—	ns	
	WS change edge SSIDATA output delay	—	25	ns	Figure 5.60



Figure 5.57 Clock Input/Output Timing



Figure 5.58 Transmit/Receive Timing (SSISCKn Rising Synchronous)



Figure 5.59 Transmit/Receive Timing (SSISCKn Falling Synchronous)



Figure 5.60 SSIDATA Output Delay from SSIWSn Change Edge

Table 5.41 MMC Host Interface Timing

Conditions: $V_{CC} = AVCC0 = AVCC1 = V_{CC_USB} = V_{BATT} = 2.7$ to 3.6 V, $2.7 \leq V_{REFH0} \leq AVCC0$,
 $V_{CC_USBA} = AVCC_USBA = 3.0$ to 3.6 V,
 $V_{SS} = AVSS0 = AVSS1 = V_{REFL0} = V_{SS_USB} = V_{SS1_USBA} = V_{SS2_USBA} = PV_{SS_USBA} = AV_{SS_USBA} = 0$ V,
 $PCLKA = 8$ to 120 MHz, $PCLKB = 8$ to 60 MHz, $T_a = T_{opr}$
 Output load conditions: $V_{OH} = V_{CC} \times 0.5$, $V_{OL} = V_{CC} \times 0.5$, $C = 30$ pF
 High-drive output is selected by the driving ability control register.

Item		Symbol	Min.*1	Max.	Unit	Test Conditions*2
MMCIF	MMC_CLK clock cycle	t_{MMCPP}	$2 \times t_{PBcyc}$	—	ns	Figure 5.61
	MMC_CLK clock high level width	t_{MMCWH}	6.5	—	ns	
	MMC_CLK clock low level width	t_{MMCWL}	6.5	—	ns	
	MMC_CLK clock rising time	t_{MMCLH}	—	5	ns	
	MMC_CLK clock falling time	t_{MMCHL}	—	5	ns	
	MMC_CMD, MMC_D7 to MMC_D0 output data delay (data transfer mode)	$t_{MMCODLY}$	-6.5	6.5	ns	
	MMC_CMD, MMC_D7 to MMC_D0 input data setup	t_{MMCISU}	8	—	ns	
	MMC_CMD, MMC_D7 to MMC_D0 input data hold	t_{MMCIH}	2	—	ns	

Note 1. t_{PBcyc} : PCLKB cycle

Note 2. We recommend using pins that have a letter (“-A”, “-B”, etc.) to indicate group membership appended to their names as groups. For the MMC interface, the AC portion of the electrical characteristics is measured for each group.

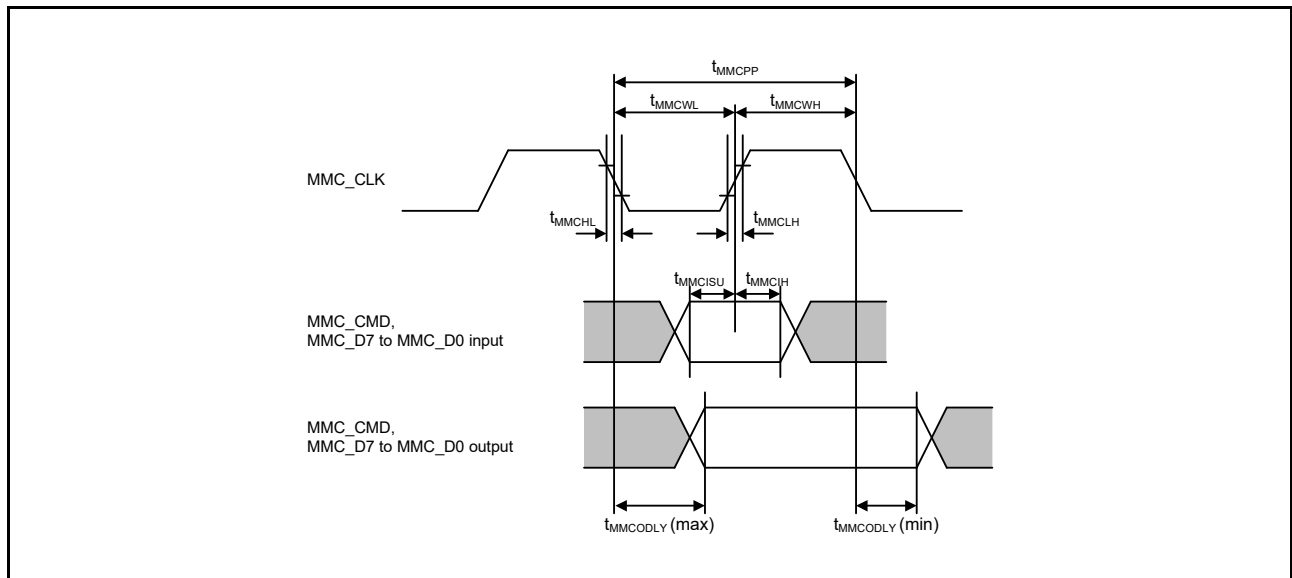

Figure 5.61 MMC Interface

Table 5.42 ETHERC Timing

Conditions: $V_{CC} = AVCC0 = AVCC1 = V_{CC_USB} = V_{BATT} = 2.7$ to 3.6 V, $2.7 \leq V_{REFH0} \leq AVCC0$,
 $V_{CC_USBA} = AVCC_USBA = 3.0$ to 3.6 V,
 $V_{SS} = AVSS0 = AVSS1 = V_{REFL0} = V_{SS_USB} = V_{SS1_USBA} = V_{SS2_USBA} = PV_{SS_USBA} = AV_{SS_USBA} = 0$ V,
 $PCLKA = 8$ to 120 MHz, $PCLKB = 8$ to 60 MHz, $T_a = T_{opr}$
 Output load conditions: $V_{OH} = V_{CC} \times 0.5$, $V_{OL} = V_{CC} \times 0.5$, $C = 30$ pF
 High-drive output is selected by the driving ability control register.

Item		Symbol	Min.	Max.	Unit	Test Conditions
ETHERC (RMII)	REF50CK cycle time	T_{ck}	20	—	ns	Figure 5.62 to Figure 5.64
	REF50CK frequency Typ. 50 MHz	—	—	50 + 100 ppm	MHz	
	REF50CK duty	—	35	65	%	
	REF50CK rise/fall time	$T_{ckr/ckf}$	0.5	3.5	ns	
	RMII_XXXX*1 output delay time	T_{co}	2.5	15.0	ns	
	RMII_XXXX*2 setup time	T_{su}	3	—	ns	
	RMII_XXXX*2 hold time	T_{hd}	1	—	ns	
	RMII_XXXX*1, *2 rise/fall time	T_r/T_f	0.5	5	ns	
	ET_WOL output delay time	t_{WOLd}	1	23.5	ns	
ETHERC (MII)	ET_TX_CLK cycle time	t_{Tcyc}	40	—	ns	—
	ET_TX_EN output delay time	t_{TENd}	1	20	ns	Figure 5.67
	ET_ETXD0 to ET_ETXD3 output delay time	t_{MTDd}	1	20	ns	
	ET_CRs setup time	t_{CRSs}	10	—	ns	
	ET_CRs hold time	t_{CRSh}	10	—	ns	Figure 5.68
	ET_COL setup time	t_{COLs}	10	—	ns	
	ET_COL hold time	t_{COLh}	10	—	ns	
	ET_RX_CLK cycle time	t_{TRcyc}	40	—	ns	—
	ET_RX_DV setup time	t_{RDVs}	10	—	ns	Figure 5.69
	ET_RX_DV hold time	t_{RDVh}	10	—	ns	
	ET_ERXD0 to ET_ERXD3 setup time	t_{MRDs}	10	—	ns	
	ET_ERXD0 to ET_ERXD3 hold time	t_{MRDh}	10	—	ns	Figure 5.70
	ET_RX_ER setup time	t_{RERs}	10	—	ns	
	ET_RX_ER hold time	t_{RESh}	10	—	ns	
	ET_WOL output delay time	t_{WOLd}	1	23.5	ns	Figure 5.71

Note 1. RMII_TXD_EN, RMII_TXD1, RMII_TXD0

Note 2. RMII_CRs_DV, RMII_RXD1, RMII_RXD0, RMII_RX_ER



Figure 5.62 Timing with the REF50CK and RMII Signals



Figure 5.63 RMIITransmission Timing



Figure 5.64 RMIIRecption Timing (Normal Operation)



Figure 5.65 RMII Reception Timing (Error Occurrence)

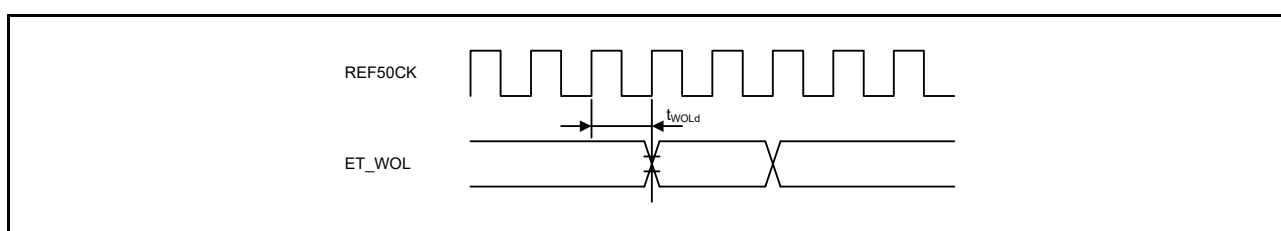

Figure 5.66 WOL Output Timing (RMII)

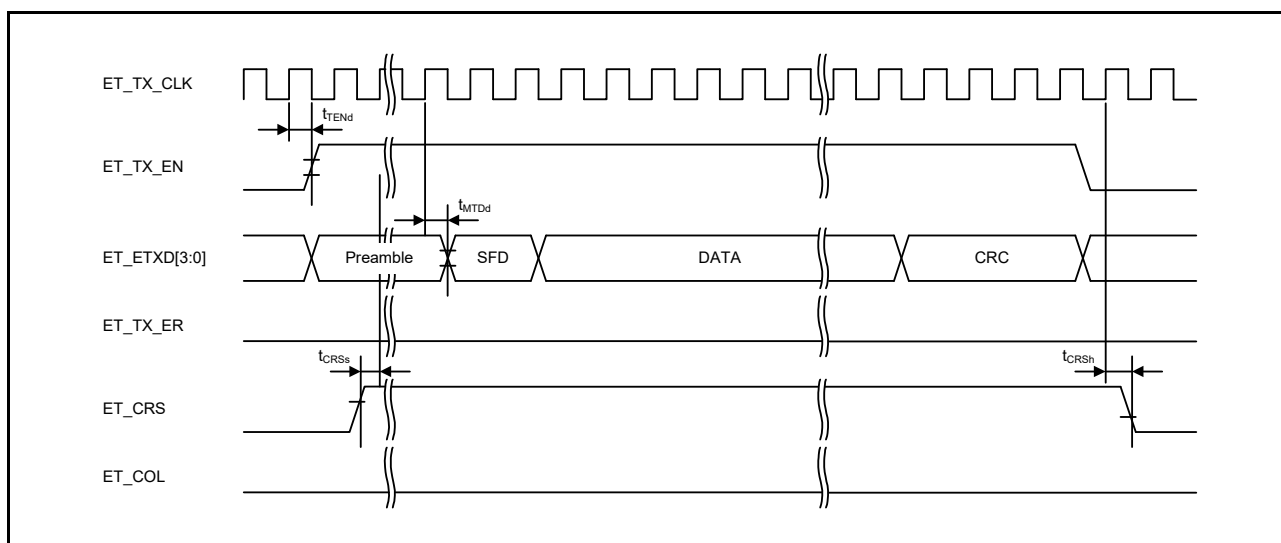

Figure 5.67 MII Transmission Timing (Normal Operation)



Figure 5.68 MII Transmission Timing (Conflict Occurrence)



Figure 5.69 MII Reception Timing (Normal Operation)



Figure 5.70 MII Reception Timing (Error Occurrence)



Figure 5.71 WOL Output Timing (MII)

Table 5.43 PDC Timing

Conditions: $V_{CC} = AVCC0 = AVCC1 = V_{CC_USB} = V_{BATT} = 2.7$ to 3.6 V, $2.7 \leq V_{REFH0} \leq AVCC0$,
 $V_{CC_USBA} = AVCC_USBA = 3.0$ to 3.6 V,
 $V_{SS} = AVSS0 = AVSS1 = V_{REFL0} = V_{SS_USB} = V_{SS1_USBA} = V_{SS2_USBA} = PV_{SS_USBA} = AV_{SS_USBA} = 0$ V,
 $PCLKA = 8$ to 120 MHz, $PCLKB = 8$ to 60 MHz, $T_a = T_{opr}$
 Output load conditions: $V_{OH} = V_{CC} \times 0.5$, $V_{OL} = V_{CC} \times 0.5$, $C = 30$ pF
 High-drive output is selected by the driving ability control register.

Item	Symbol	Min.*1	Max.	Unit	Test Conditions	
PDC	PIXCLK input cycle time	t_{PIXcyc}	37	—	ns	Figure 5.72
	PIXCLK input high pulse width	t_{PIXH}	10	—	ns	
	PIXCLK input low pulse width	t_{PIXL}	10	—	ns	
	PIXCLK rising time	t_{PIXr}	—	5	ns	
	PIXCLK falling time	t_{PIXf}	—	5	ns	
PDC	PCKO output cycle time	t_{PCKcyc}	$2 \times t_{PBcyc}$	—	ns	Figure 5.73
	PCKO output high pulse width	t_{PCKH}	$(t_{PCKcyc} - t_{PCKr} - t_{PCKf})/2 - 3$	—	ns	
	PCKO output low pulse width	t_{PCKL}	$(t_{PCKcyc} - t_{PCKr} - t_{PCKf})/2 - 3$	—	ns	
	PCKO rising time	t_{PCKr}	—	5	ns	
	PCKO falling time	t_{PCKf}	—	5	ns	
PDC	VSYNV/HSYNC input setup time	t_{SYNCS}	10	—	ns	Figure 5.74
	VSYNV/HSYNC input hold time	t_{SYNCH}	5	—	ns	
	PIXD input setup time	t_{PIXDS}	10	—	ns	
	PIXD input hold time	t_{PIXDH}	5	—	ns	

Note 1. t_{PBcyc} : PCLKB cycle



Figure 5.72 PDC Input Clock Timing



Figure 5.73 PDC Output Clock Timing



Figure 5.74 PDC AC Timing

5.4 USB Characteristics

Table 5.44 On-Chip USB Low Speed (Host Only) Characteristics (DP and DM Pin Characteristics)

Conditions: $V_{CC} = AV_{CC0} = AV_{CC1} = V_{CC_USB} = V_{BATT} = 3.0$ to 3.6 V, $3.0 \leq V_{REFH0} \leq AV_{CC0}$,
 $V_{CC_USBA} = AV_{CC_USBA} = 3.0$ to 3.6 V,
 $V_{SS} = AV_{SS0} = AV_{SS1} = V_{REFL0} = V_{SS_USB} = V_{SS1_USBA} = V_{SS2_USBA} = PV_{SS_USBA} = AV_{SS_USBA} = 0$ V,
 $USBA_RREF = 2.2$ k $\Omega \pm 1\%$, $USBMCLK = 20/24$ MHz, $UCLK = 48$ MHz,
 $PCLKA = 8$ to 120 MHz, $PCLKB = 8$ to 60 MHz, $T_a = T_{opr}$

Item		Symbol	Min.	Typ.	Max.	Unit	Test Conditions
Input characteristics	Input high level voltage	V_{IH}	2.0	—	—	V	
	Input low level voltage	V_{IL}	—	—	0.8	V	
	Differential input sensitivity	V_{DI}	0.2	—	—	V	DP – DM
	Differential common mode range	V_{CM}	0.8	—	2.5	V	
Output characteristics	Output high level voltage	V_{OH}	2.8	—	3.6	V	$I_{OH} = -200 \mu A$
	Output low level voltage	V_{OL}	0.0	—	0.3	V	$I_{OL} = 2$ mA
	Cross-over voltage	V_{CRS}	1.3	—	2.0	V	Figure 5.75
	Rise time	t_{LR}	75	—	300	ns	Figure 5.75
	Fall time	t_{LF}	75	—	300	ns	
	Rise/fall time ratio	t_{LR} / t_{LF}	80	—	125	%	t_{LR} / t_{LF}
Pull-up and pull-down characteristics	DP/DM pull-down resistance (when the host controller function is selected)	R_{pd}	14.25	—	24.80	k Ω	



Figure 5.75 DP and DM Output Timing (Low Speed)



Figure 5.76 Test Circuit (Low Speed)

Table 5.45 On-Chip USB Full-Speed Characteristics (DP and DM Pin Characteristics)

Conditions: $V_{CC} = AVCC0 = AVCC1 = V_{CC_USB} = V_{BATT} = 3.0$ to 3.6 V, $3.0 \leq V_{REFH0} \leq AVCC0$,
 $V_{CC_USBA} = AVCC_USBA = 3.0$ to 3.6 V,
 $V_{SS} = AVSS0 = AVSS1 = V_{REFL0} = V_{SS_USB} = V_{SS1_USBA} = V_{SS2_USBA} = PV_{SS_USBA} = AV_{SS_USBA} = 0$ V,
 $USBA_RREF = 2.2$ k $\Omega \pm 1\%$, $USBMCLK = 20/24$ MHz, $UCLK = 48$ MHz,
 $PCLKA = 8$ to 120 MHz, $PCLKB = 8$ to 60 MHz, $T_a = T_{opr}$

Item	Symbol	Min.	Typ.	Max.	Unit	Test Conditions	
Input characteristics	Input high level voltage	V_{IH}	2.0	—	—	V	
	Input low level voltage	V_{IL}	—	—	0.8	V	
	Differential input sensitivity	V_{DI}	0.2	—	—	V	DP – DM
	Differential common mode range	V_{CM}	0.8	—	2.5	V	
Output characteristics	Output high level voltage	V_{OH}	2.8	—	3.6	V	$I_{OH} = -200 \mu A$
	Output low level voltage	V_{OL}	0.0	—	0.3	V	$I_{OL} = 2$ mA
	Cross-over voltage	V_{CRS}	1.3	—	2.0	V	Figure 5.77
	Rise time	t_{FR}	4	—	20	ns	
	Fall time	t_{FF}	4	—	20	ns	
	Rise/fall time ratio	t_{FR} / t_{FF}	90	—	111.11	%	t_{FR} / t_{FF}
	Output resistance	Z_{DRV}	28	—	44	Ω	USBb: $R_s = 27 \Omega$ included
Pull-up and pull-down characteristics	DP pull-up resistance (when the function controller function is selected)	R_{pu}	0.900	—	1.575	k Ω	Idle state
		R_{pu}	1.425	—	3.090	k Ω	At transmission and reception
	DP/DM pull-down resistance (when the host controller function is selected)	R_{pd}	14.25	—	24.80	k Ω	



Figure 5.77 DP and DM Output Timing (Full-Speed)

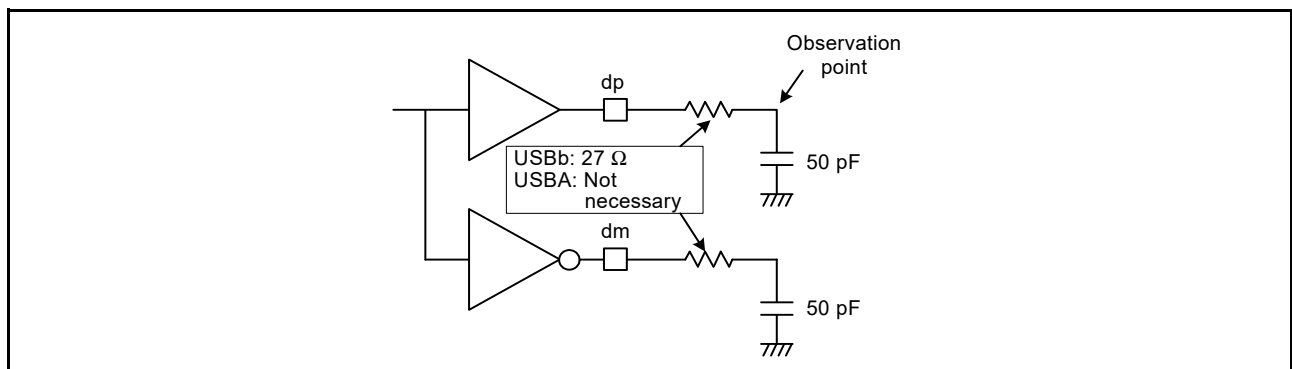

Figure 5.78 Test Circuit (Full-Speed)

Table 5.46 On-Chip USB High-Speed Characteristics (DP and DM Pin Characteristics)

Conditions: $V_{CC} = AV_{CC0} = AV_{CC1} = V_{CC_USB} = V_{BATT} = 3.0$ to 3.6 V, $3.0 \leq V_{REFH0} \leq AV_{CC0}$,
 $V_{CC_USBA} = AV_{CC_USBA} = 3.0$ to 3.6 V,
 $V_{SS} = AV_{SS0} = AV_{SS1} = V_{REFL0} = V_{SS_USB} = V_{SS1_USBA} = V_{SS2_USBA} = PV_{SS_USBA} = AV_{SS_USBA} = 0$ V,
 $USBA_RREF = 2.2$ k $\Omega \pm 1\%$, $USBMCLK = 20/24$ MHz, $PCLKA = 8$ to 120 MHz, $PCLKB = 8$ to 60 MHz, $T_a = T_{opr}$

Item		Symbol	Min.	Typ.	Max.	Unit	Test Conditions
Input characteristics	Squelch detect sensitivity (Differential voltage)	V_{HSSQ}	100	—	150	mV	Figure 5.79
	Disconnect detect sensitivity	V_{HSDSC}	525	—	625	mV	Figure 5.80
	Common mode voltage	V_{HSCM}	-50	—	500	mV	
Output characteristics	Idle state	V_{HSOI}	-10	—	10	mV	Figure 5.81
	Output high level voltage	V_{HSOH}	360	—	440	mV	
	Output low level voltage	V_{HSOL}	-10	—	10	mV	
	Chirp J output voltage (difference)	V_{CHIRPJ}	700	—	1100	mV	
	Chirp K output voltage (difference)	V_{CHIRPK}	-900	—	-500	mV	
AC characteristics	Rise time	t_{HSR}	500	—	—	ps	Figure 5.81
	Fall time	t_{HSF}	500	—	—	ps	
	Output resistance	Z_{HSDRV}	40.5	—	49.5	Ω	



Figure 5.79 DP and DM Squelch detect sensitivity (High-Speed)



Figure 5.80 DP and DM Disconnect detect sensitivity (High-Speed)



Figure 5.81 DP and DM Output Timing (High-Speed)



Figure 5.82 Test Circuit (High-Speed)

Table 5.47 Battery Charge Characteristics (USBA only)

Conditions: $V_{CC} = AVCC0 = AVCC1 = V_{CC_USB} = V_{BATT} = 2.7$ to 3.6 V, $2.7 \leq V_{REFH0} \leq AVCC0$,
 $V_{CC_USBA} = AVCC_USBA = 3.0$ to 3.6 V,
 $V_{SS} = AVSS0 = AVSS1 = V_{REFL0} = V_{SS_USB} = V_{SS1_USBA} = V_{SS2_USBA} = PV_{SS_USBA} =$
 $AV_{SS_USBA} = 0$ V, $USBA_RREF = 2.2$ k $\Omega \pm 1\%$, $USBMCLK = 20/24$ MHz, $PCLKA = 8$ to 120 MHz,
 $PCLKB = 8$ to 60 MHz, $T_a = T_{opr}$

Item	Symbol	Min.	Max.	Unit	Test Conditions
D+ sink current	I_{DP_SINK}	25	175	μ A	
D- sink current	I_{DM_SINK}	25	175	μ A	
DCD source current	I_{DP_SRC}	7	13	μ A	
Data detection voltage	V_{DAT_REF}	0.25	0.4	V	
D+ source voltage	V_{DP_SRC}	0.5	0.7	V	Output current = 250 μ A
D- source voltage	V_{DM_SRC}	0.5	0.7	V	Output current = 250 μ A

5.5 A/D Conversion Characteristics

Table 5.48 12-Bit A/D (Unit 0) Conversion Characteristics

Conditions: $VCC = AVCC0 = AVCC1 = VCC_USB = V_{BATT} = 2.7$ to 3.6 V, $2.7 \leq VREFH0 \leq AVCC0$,
 $VCC_USBA = AVCC_USBA = 3.0$ to 3.6 V,
 $VSS = AVSS0 = AVSS1 = VREFL0 = VSS_USB = VSS1_USBA = VSS2_USBA = PVSS_USBA = AVSS_USBA = 0$ V,
 $PCLKB = PCLKC = 1$ MHz to 60 MHz, $T_a = T_{opr}$

Item	Min.	Typ.	Max.	Unit	Test Conditions	
Resolution	8	—	12	Bit		
Analog input capacitance	—	—	30	pF		
Channel-dedicated sample-and-hold circuits in use (AN000 to AN002)	Conversion time*1 (Operation at PCLK = 60 MHz) Permissible signal source impedance (max.) = 1.0 k Ω	1.06 (0.40 + 0.25) *2	—	—	μ s	<ul style="list-style-type: none"> • Sampling of channel-dedicated sample-and-hold circuits in 24 states • Sampling in 15 states
	Offset error	—	± 1.5	± 3.5	LSB	AN000 to AN002 = 0.25 V
	Full-scale error	—	± 1.5	± 3.5	LSB	AN000 to AN002 = VREFH0 - 0.25 V
	Quantization error	—	± 0.5	—	LSB	
	Absolute accuracy	—	± 2.5	± 5.5	LSB	
	DNL differential nonlinearity error	—	± 1.0	± 2.0	LSB	
	INL integral nonlinearity error	—	± 1.5	± 3.0	LSB	
	Holding characteristics of sample-and-hold circuits	—	—	20	μ s	
	Dynamic range	0.25	—	VREFH0 - 0.25	V	
Channel-dedicated sample-and-hold circuits not in use (AN000 to AN007)	Conversion time*1 (Operation at PCLK = 60 MHz) Permissible signal source impedance (max.) = 1.0 k Ω	0.48 (0.267) *2	—	—	μ s	Sampling in 16 states
	Offset error	—	± 1.0	± 2.5	LSB	
	Full-scale error	—	± 1.0	± 2.5	LSB	
	Quantization error	—	± 0.5	—	LSB	
	Absolute accuracy	—	± 2.0	± 4.5	LSB	
	DNL differential nonlinearity error	—	± 0.5	± 1.5	LSB	
	INL integral nonlinearity error	—	± 1.0	± 2.5	LSB	

Note: The above specification values apply when there is no access to the external bus during A/D conversion. If access proceeds during A/D conversion, values may not fall within the above ranges.

Note 1. The conversion time includes the sampling time and the comparison time. As the test conditions, the number of sampling states is indicated.

Note 2. The value in parentheses indicates the sampling time.

Table 5.49 12-Bit A/D (Unit 1) Conversion Characteristics

Conditions: $V_{CC} = AVCC0 = AVCC1 = V_{CC_USB} = V_{BATT} = 2.7$ to 3.6 V, $2.7 \leq V_{REFH0} \leq AVCC0$,
 $V_{CC_USBA} = AVCC_USBA = 3.0$ to 3.6 V,
 $V_{SS} = AVSS0 = AVSS1 = V_{REFL0} = V_{SS_USB} = V_{SS1_USBA} = V_{SS2_USBA} = PV_{SS_USBA} = AV_{SS_USBA} = 0$ V,
 $PCLKB = PCLKD = 1$ MHz to 60 MHz, $T_a = T_{opr}$

Item		Min.	Typ.	Max.	Unit	Test Conditions
Resolution		8	—	12	Bit	
Conversion time*1 (Operation at PCLK = 60 MHz)	Permissible signal source impedance (max.) = 1.0 k Ω	0.88 (0.667) *2	—	—	μ s	Sampling in 40 states
Analog input capacitance		—	—	30	pF	
Offset error		—	± 2.0	± 3.5	LSB	
Full-scale error		—	± 2.0	± 3.5	LSB	
Quantization error		—	± 0.5	—	LSB	
Absolute accuracy		—	± 4.0	± 6.0	LSB	
DNL differential nonlinearity error		—	± 1.5	± 2.5	LSB	
INL integral nonlinearity error		—	± 2.0	± 3.5	LSB	

Note: The above specification values apply when there is no access to the external bus during A/D conversion. If access proceeds during A/D conversion, values may not fall within the above ranges.

Note 1. The conversion time includes the sampling time and the comparison time. As the test conditions, the number of sampling states is indicated.

Note 2. The value in parentheses indicates the sampling time.

Table 5.50 A/D Internal Reference Voltage Characteristics

Conditions: $V_{CC} = AVCC0 = AVCC1 = V_{CC_USB} = V_{BATT} = 2.7$ to 3.6 V, $2.7 \leq V_{REFH0} \leq AVCC0$,
 $V_{CC_USBA} = AVCC_USBA = 3.0$ to 3.6 V,
 $V_{SS} = AVSS0 = AVSS1 = V_{REFL0} = V_{SS_USB} = V_{SS1_USBA} = V_{SS2_USBA} = PV_{SS_USBA} = AV_{SS_USBA} = 0$ V,
 $PCLKB = PCLKD = 60$ MHz, $T_a = T_{opr}$

Item	Min.	Typ.	Max.	Unit	Test Conditions
A/D internal reference voltage	1.20	1.25	1.30	V	

5.6 D/A Conversion Characteristics

Table 5.51 D/A Conversion Characteristics

Conditions: $V_{CC} = AVCC0 = AVCC1 = V_{CC_USB} = V_{BATT} = 2.7$ to 3.6 V,
 $2.7 \leq V_{REFH0} \leq AVCC0$, $V_{CC_USBA} = AVCC_USBA = 3.0$ to 3.6 V,
 $V_{SS} = AVSS0 = AVSS1 = V_{REFL0} = V_{SS_USB} = V_{SS1_USBA} = V_{SS2_USBA} = PV_{SS_USBA} = AV_{SS_USBA} = 0$ V,
 $T_a = T_{opr}$

Item		Min.	Typ.	Max.	Unit	Test Conditions
Resolution		12	12	12	Bit	
Without AMP output	Absolute accuracy	—	—	±6.0	LSB	2-MΩ resistive load 10-bit conversion
	DNL differential nonlinearity error	—	±1.0	±2.0	LSB	2-MΩ resistive load
	RO output resistance	—	7.5	—	kΩ	
	Conversion time	—	—	3.0	μs	20-pF capacitive load
With AMP output	Resistive load	5	—	—	kΩ	
	Capacitive load	—	—	50	pF	
	Output voltage range	0.2	—	$AVCC1 - 0.2$	V	
	DNL differential nonlinearity error	—	±1.0	±2.0	LSB	
	INL integral nonlinearity error	—	±2.0	±4.0	LSB	
	Conversion time	—	—	4.0	μs	

5.7 Temperature Sensor Characteristics

Table 5.52 Temperature Sensor Characteristics

Conditions: $V_{CC} = AVCC0 = AVCC1 = V_{CC_USB} = V_{BATT} = 2.7$ to 3.6 V, $2.7 \leq V_{REFH0} \leq AVCC0$,
 $V_{CC_USBA} = AVCC_USBA = 3.0$ to 3.6 V,
 $V_{SS} = AVSS0 = AVSS1 = V_{REFL0} = V_{SS_USB} = V_{SS1_USBA} = V_{SS2_USBA} = PV_{SS_USBA} = AV_{SS_USBA} = 0$ V,
 $T_a = T_{opr}$

Item	Min.	Typ.	Max.	Unit	Test Conditions
Relative accuracy	—	±1	—	°C	
Temperature slope	—	4.1	—	mV/°C	
Output voltage (at 25°C)	—	1.24	—	V	
Temperature sensor start time	—	—	30	μs	
Sampling time*1	4.15	—	—	μs	

Note 1. Set the S12AD1.ADSSTRT register such that the sampling time of the 12-bit A/D converter satisfies this specification.

5.8 Power-on Reset Circuit and Voltage Detection Circuit Characteristics

Table 5.53 Power-on Reset Circuit and Voltage Detection Circuit Characteristics

Conditions: $V_{CC} = AVCC0 = AVCC1 = V_{CC_USB} = V_{BATT} = 2.7$ to 3.6 V, $2.7 \leq V_{REFH0} \leq AVCC0$,
 $V_{CC_USBA} = AVCC_USBA = 3.0$ to 3.6 V,
 $V_{SS} = AVSS0 = AVSS1 = V_{REFL0} = V_{SS_USB} = V_{SS1_USBA} = V_{SS2_USBA} = PV_{SS_USBA} = AV_{SS_USBA} = 0$ V,
 $T_a = T_{opr}$

Item		Symbol	Min.	Typ.	Max.	Unit	Test Conditions	
Voltage detection level	Power-on reset (POR)	Low power consumption function disabled*1	V_{POR}	2.5	2.6	2.7	V	Figure 5.83
		Low power consumption function enabled*2		2.0	2.35	2.7		
	Voltage detection circuit (LVD0)		V_{det0_1}	2.84	2.94	3.04		Figure 5.84
			V_{det0_2}	2.77	2.87	2.97		
			V_{det0_3}	2.70	2.80	2.90		
	Voltage detection circuit (LVD1)		V_{det1_1}	2.89	2.99	3.09		Figure 5.85
			V_{det1_2}	2.82	2.92	3.02		
			V_{det1_3}	2.75	2.85	2.95		
	Voltage detection circuit (LVD2)		V_{det2_1}	2.89	2.99	3.09		Figure 5.86
			V_{det2_2}	2.82	2.92	3.02		
			V_{det2_3}	2.75	2.85	2.95		
	Internal reset time	Power-on reset time	t_{POR}	—	4.6	—	ms	Figure 5.83
LVD0 reset time		t_{LVD0}	—	0.70	—	Figure 5.84		
LVD1 reset time		t_{LVD1}	—	0.57	—	Figure 5.85		
LVD2 reset time		t_{LVD2}	—	0.57	—	Figure 5.86		
Minimum VCC down time		t_{VOFF}	200	—	—	μ s	Figure 5.83, Figure 5.84	
Response delay time		t_{det}	—	—	200	μ s	Figure 5.83 to Figure 5.86	
LVD operation stabilization time (after LVD is enabled)*3		$T_{d(E-A)}$	—	—	10	μ s	Figure 5.85, Figure 5.86	
Hysteresis width (LVD1 and LVD2)		V_{LVH}	—	80	—	mV		

Note: The minimum VCC down time indicates the time when VCC is below the minimum value of voltage detection levels V_{POR} , V_{det1} , and V_{det2} for the POR/ LVD.

Note 1. The low power consumption function is disabled and DEEPCUT[1:0] = 00b or 01b.

Note 2. The low power consumption function is enabled and DEEPCUT[1:0] = 11b.

Note 3. The voltage of $V_{CC} = AVCC0 = AVCC1$ when LVD1 is enabled must be set to at least 80 mV above the maximum value of the voltage detection 1 level ($V_{det1_1, 2, 3}$) selected by the LVDLVL.R.LVD1LVL[3:0] bits. Similarly, the voltage of $V_{CC} = AVCC0 = AVCC1$ when LVD2 is enabled must be set to at least 80 mV above the maximum value of the voltage detection 2 level ($V_{det2_1, 2, 3}$) selected by the LVDLVL.R.LVD2LVL[3:0] bits.



Figure 5.83 Power-on Reset Timing



Figure 5.84 Voltage Detection Circuit Timing (V_{det0})

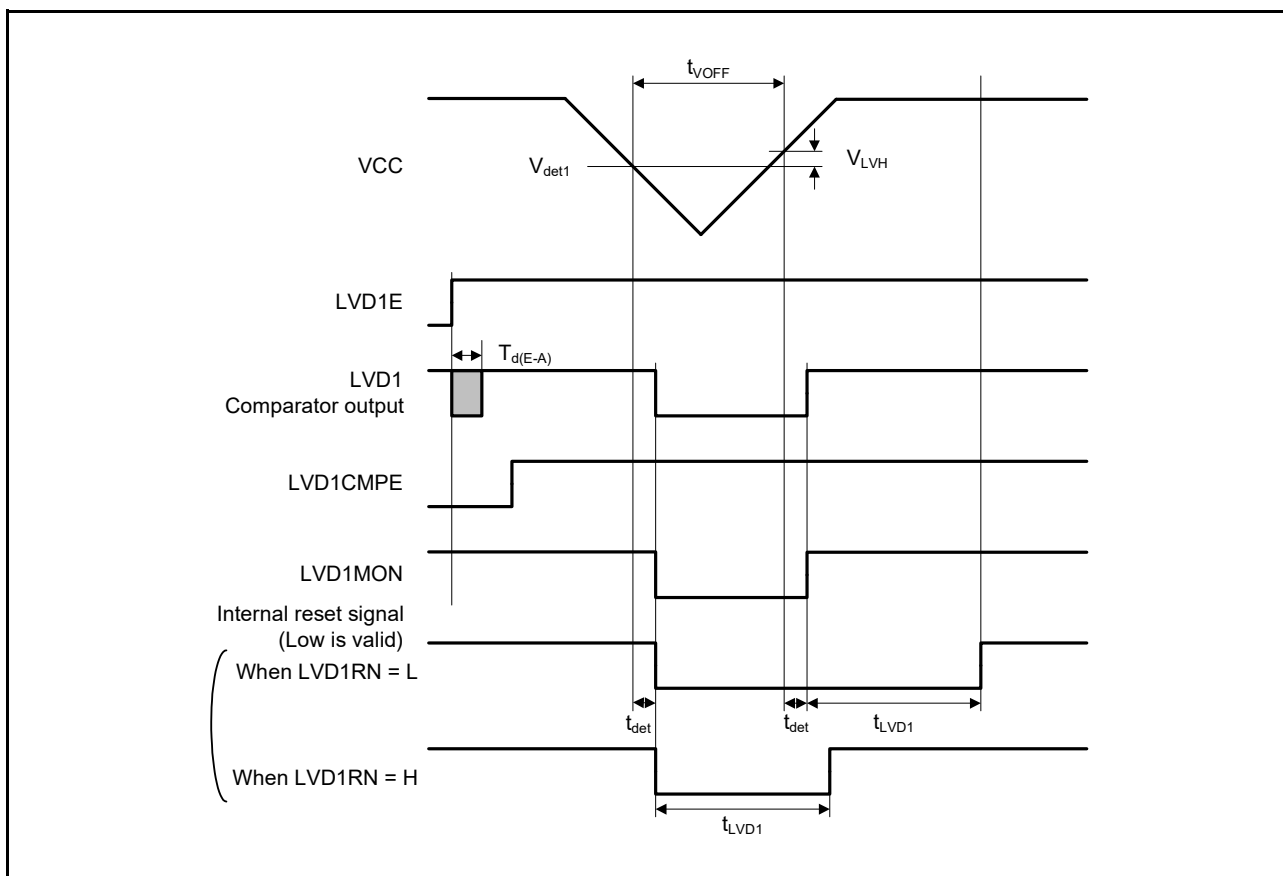

Figure 5.85 Voltage Detection Circuit Timing (V_{det1})

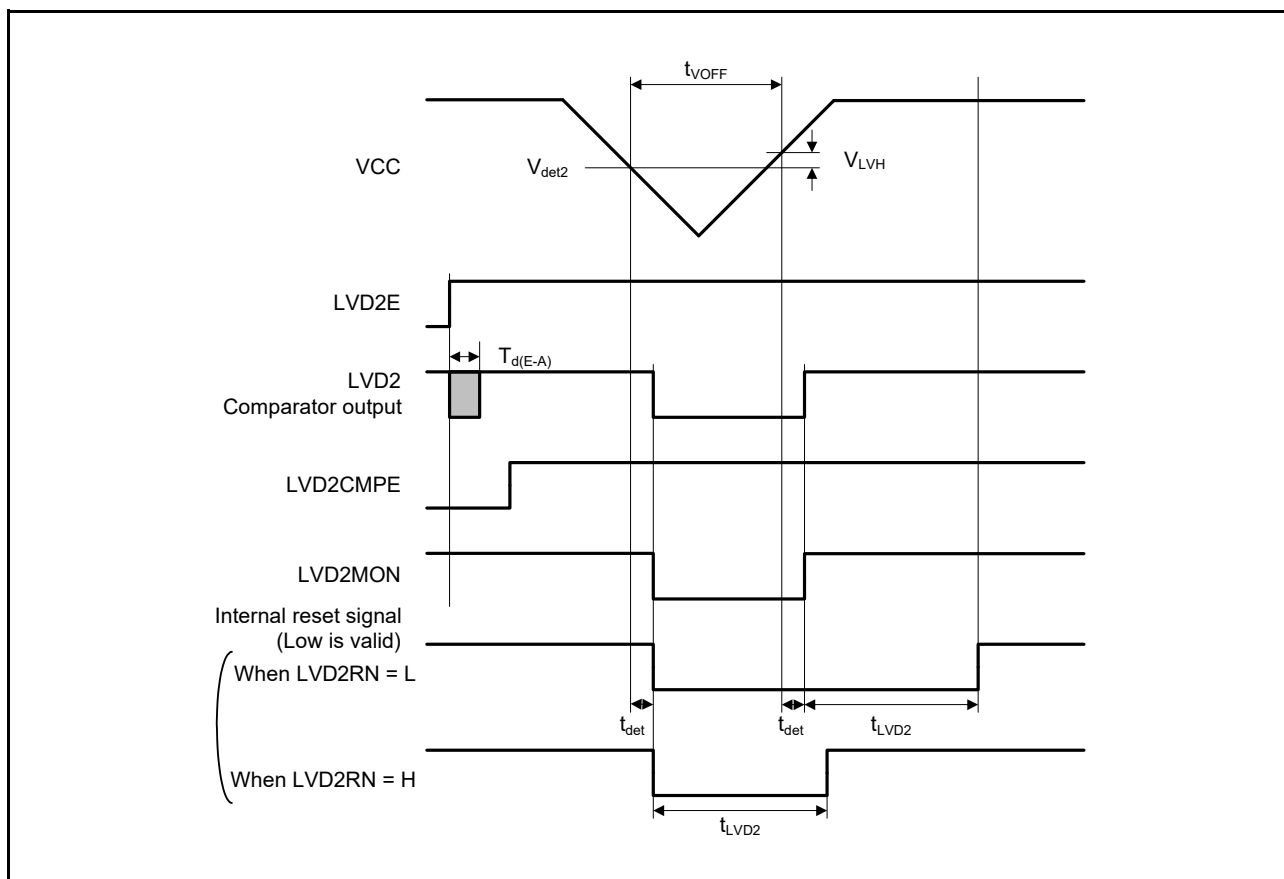

Figure 5.86 Voltage Detection Circuit Timing (V_{det2})

5.9 Oscillation Stop Detection Timing

Table 5.54 Oscillation Stop Detection Circuit Characteristics

Conditions: $V_{CC} = AVCC0 = AVCC1 = V_{CC_USB} = V_{BATT} = 2.7$ to 3.6 V, $2.7 \leq V_{REFH0} \leq AVCC0$,
 $V_{CC_USBA} = AVCC_USBA = 3.0$ to 3.6 V,
 $V_{SS} = AVSS0 = AVSS1 = V_{REFL0} = V_{SS_USB} = V_{SS1_USBA} = V_{SS2_USBA} = PV_{SS_USBA} = AV_{SS_USBA} = 0$ V,
 $T_a = T_{opr}$

Item	Symbol	Min.	Typ.	Max.	Unit	Test Conditions
Detection time	t_{dr}	—	—	1	ms	Figure 5.87

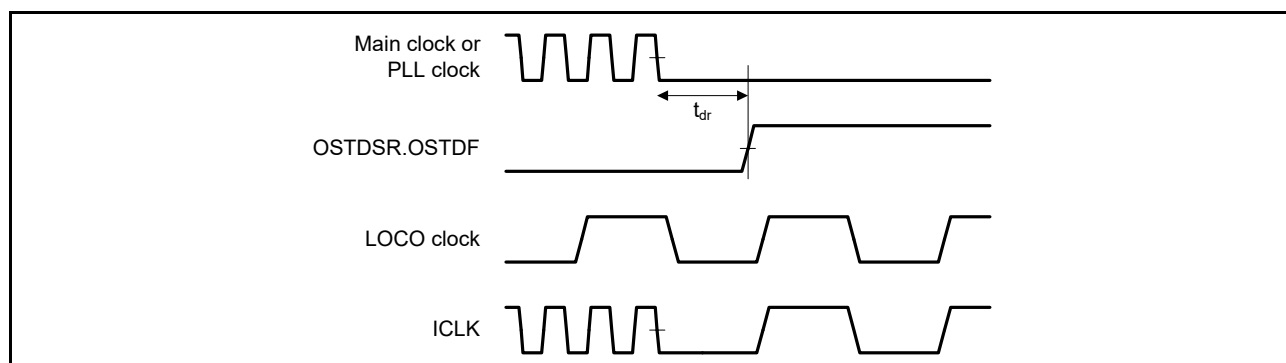

Figure 5.87 Oscillation Stop Detection Timing

5.10 Battery Backup Function Characteristics

Table 5.55 Battery Backup Function Characteristics

Conditions: $V_{CC} = AV_{CC0} = AV_{CC1} = V_{CC_USB} = 2.7$ to 3.6 V, $2.7 \leq V_{REFH0} \leq AV_{CC0}$,
 $V_{CC_USBA} = AV_{CC_USBA} = 3.0$ to 3.6 V,
 $V_{SS} = AV_{SS0} = AV_{SS1} = V_{REFL0} = V_{SS_USB} = V_{SS1_USBA} = V_{SS2_USBA} = PV_{SS_USBA} = AV_{SS_USBA} = 0$ V,
 $V_{BATT} = 2.0$ to 3.6 V, $T_a = T_{opr}$

Item	Symbol	Min.	Typ.	Max.	Unit	Test Conditions
Voltage level for switching to battery backup	$V_{DETBATT}$	2.50	2.60	2.70	V	Figure 5.88
Lower-limit V_{BATT} voltage for power supply switching due to VCC voltage drop	V_{BATTSW}	2.70	—	—		
VCC-off period for starting power supply switching	$t_{VOFFBATT}$	200	—	—	μ s	

Note: The VCC-off period for starting power supply switching indicates the period in which VCC is below the minimum value of the voltage level for switching to battery backup ($V_{DETBATT}$).



Note. The VBATT voltage when the supplied power source switches from Vcc to V_{BATT} should not be lower than V_{BATTSW} , the lower-limit VBATT voltage for switching between power supplies due to a drop in the VCC voltage.

Figure 5.88 Battery Backup Function Characteristics

5.11 Flash Memory Characteristics

Table 5.56 Code Flash Memory Characteristics

Conditions: $V_{CC} = AV_{CC0} = AV_{CC1} = V_{CC_USB} = V_{BATT} = 2.7$ to 3.6 V, $2.7 \leq V_{REFH0} \leq AV_{CC0}$,
 $V_{CC_USBA} = AV_{CC_USBA} = 3.0$ to 3.6 V,
 $V_{SS} = AV_{SS0} = AV_{SS1} = V_{REFL0} = V_{SS_USB} = V_{SS1_USBA} = V_{SS2_USBA} = PV_{SS_USBA} = AV_{SS_USBA} = 0$ V
 Temperature range for programming/erasure: $T_a = T_{opr}$

Item	Symbol	FCLK = 4 MHz			20 MHz ≤ FCLK ≤ 60 MHz			Unit	
		Min.	Typ.	Max.	Min.	Typ.	Max.		
Programming time $N_{PEC} \leq 100$ times	256 bytes	t_{P256}	—	0.9	13.2	—	0.4	6	ms
	8 Kbytes	t_{P8K}	—	29	176	—	13	80	ms
	32 Kbytes	t_{P32K}	—	116	704	—	52	320	ms
Programming time $N_{PEC} > 100$ times	256 bytes	t_{P256}	—	1.1	15.8	—	0.5	7.2	ms
	8 Kbytes	t_{P8K}	—	35	212	—	16	96	ms
	32 Kbytes	t_{P32K}	—	140	848	—	64	384	ms
Erasure time $N_{PEC} \leq 100$ times	8 Kbytes	t_{E8K}	—	71	216	—	39	120	ms
	32 Kbytes	t_{E32K}	—	254	864	—	141	480	ms
Erasure time $N_{PEC} > 100$ times	8 Kbytes	t_{E8K}	—	85	260	—	47	144	ms
	32 Kbytes	t_{E32K}	—	304	1040	—	169	576	ms
Reprogramming/erasure cycle*1	N_{PEC}	1000*2	—	—	1000*2	—	—	—	Times
Suspend delay time during programming	t_{SPD}	—	—	264	—	—	120	120	μs
First suspend delay time during erasing (in suspend priority mode)	t_{SESD1}	—	—	216	—	—	120	120	μs
Second suspend delay time during erasure (in suspend priority mode)	t_{SESD2}	—	—	1.7	—	—	1.7	1.7	ms
Suspend delay time during erasure (in erasure priority mode)	t_{SEED}	—	—	1.7	—	—	1.7	1.7	ms
Forced stop command	t_{FD}	—	—	32	—	—	20	20	μs
Data hold time*3	t_{DRP}	10	—	—	10	—	—	—	Year
FCU reset time	t_{FCUR}	35	—	—	35	—	—	—	μs

Note 1. Definition of reprogram/erase cycle:

The reprogram/erase cycle is the number of erasing for each block. When the reprogram/erase cycle is n times ($n = 1000$), erasing can be performed n times for each block. For instance, when 256-byte programming is performed 32 times for different addresses in 8-Kbyte block and then the entire block is erased, the reprogram/erase cycle is counted as one. However, programming the same address for several times as one erasing is not enabled (overwriting is prohibited).

Note 2. This is the minimum number of times to guarantee all the characteristics after reprogramming (guaranteed range is from 1 to the value of the minimum value).

Note 3. This shows the characteristics when reprogramming is performed within the specified range, including the minimum value.

Table 5.57 Data Flash Memory Characteristics

Conditions: $V_{CC} = AVCC0 = AVCC1 = V_{CC_USB} = V_{BATT} = 2.7$ to 3.6 V, $2.7 \leq V_{REFH0} \leq AVCC0$,
 $V_{CC_USBA} = AVCC_USBA = 3.0$ to 3.6 V
 $V_{SS} = AVSS0 = AVSS1 = V_{REFL0} = V_{SS_USB} = V_{SS1_USBA} = V_{SS2_USBA} = PV_{SS_USBA} = AV_{SS_USBA} = 0$ V,
 Temperature range for programming/erasure: $T_a = T_{opr}$

Item	Symbol	FCLK = 4 MHz			20 MHz ≤ FCLK ≤ 60 MHz			Unit	
		Min.	Typ.	Max.	Min.	Typ.	Max.		
Programming time	4 bytes	t_{DP4}	—	0.36	3.8	—	0.16	1.7	ms
Erasure time	64 bytes	t_{DE64}	—	3.1	18	—	1.7	10	ms
Blank check time	4 bytes	t_{DBC4}	—	—	84	—	—	30	μs
	64 bytes	t_{DBC64}	—	—	280	—	—	100	μs
	2 Kbytes	t_{DBC2K}	—	—	6169	—	—	2200	μs
Reprogramming/erasure cycle*1		N_{DPEC}	100000 *2	—	—	100000 *2	—	—	Times
Suspend delay time during programming		t_{DSPD}	—	—	264	—	—	120	μs
First suspend delay time during erasure (in suspend priority mode)		t_{DSESD1}	—	—	216	—	—	120	μs
Second suspend delay time during erasure (in suspend priority mode)		t_{DSESD2}	—	—	300	—	—	300	μs
Suspend delay time during erasing (in erasure priority mode)		t_{DSEED}	—	—	300	—	—	300	μs
Forced stop command		t_{FD}	—	—	32	—	—	20	μs
Data hold time*3		t_{DDRP}	10	—	—	10	—	—	Year

Note 1. Definition of reprogram/erase cycle:

The reprogram/erase cycle is the number of erasing for each block. When the reprogram/erase cycle is n times (n = 100000), erasing can be performed n times for each block. For instance, when 4-byte programming is performed 512 times for different addresses in 2-Kbyte block and then the entire block is erased, the reprogram/erase cycle is counted as one. However, programming the same address for several times as one erasing is not enabled (overwriting is prohibited).

Note 2. This is the minimum number of times to guarantee all the characteristics after reprogramming (guaranteed range is from 1 to the value of the minimum value).

Note 3. This shows the characteristics when reprogramming is performed within the specified range, including the minimum value.



Figure 5.89 Flash Memory Programming/Erasure Suspension Timing

5.12 Boundary Scan

Table 5.58 Boundary Scan Characteristics

Conditions: $V_{CC} = AV_{CC0} = AV_{CC1} = V_{CC_USB} = V_{BATT} = 2.7$ to 3.6 V, $2.7 \leq V_{REFH0} \leq AV_{CC0}$,
 $V_{CC_USBA} = AV_{CC_USBA} = 3.0$ to 3.6 V,
 $V_{SS} = AV_{SS0} = AV_{SS1} = V_{REFL0} = V_{SS_USB} = V_{SS1_USBA} = V_{SS2_USBA} = PV_{SS_USBA} = AV_{SS_USBA} = 0$ V,
 $T_a = T_{opr}$
 Output load conditions: $V_{OH} = V_{CC} \times 0.5$, $V_{OL} = V_{CC} \times 0.5$, $C = 30$ pF
 High-drive output is selected by the driving ability control register.

Item	Symbol	Min.	Typ.	Max.	Unit	Test Conditions
TCK clock cycle time	t_{TCKcyc}	100	—	—	ns	Figure 5.90
TCK clock high pulse width	t_{TCKH}	45	—	—	ns	
TCK clock low pulse width	t_{TCKL}	45	—	—	ns	
TCK clock rise time	t_{TCKr}	—	—	5	ns	
TCK clock fall time	t_{TCKf}	—	—	5	ns	
TRST# pulse width	t_{TRSTW}	20	—	—	t_{TCKcyc}	Figure 5.91
TMS setup time	t_{TMSS}	20	—	—	ns	Figure 5.92
TMS hold time	t_{TMSH}	20	—	—	ns	
TDI setup time	t_{TDIS}	20	—	—	ns	
TDI hold time	t_{TDIH}	20	—	—	ns	
TDO data delay time	t_{TDOD}	—	—	40	ns	



Figure 5.90 Boundary Scan TCK Timing



Figure 5.91 Boundary Scan TRST# Timing



Figure 5.92 Boundary Scan Input/Output Timing

Appendix 1. Package Dimensions

Information on the latest version of the package dimensions or mountings has been displayed in “Packages” on Renesas Electronics Corporation website.



Figure A 177-Pin TFLGA (PTLG0177KA-A)

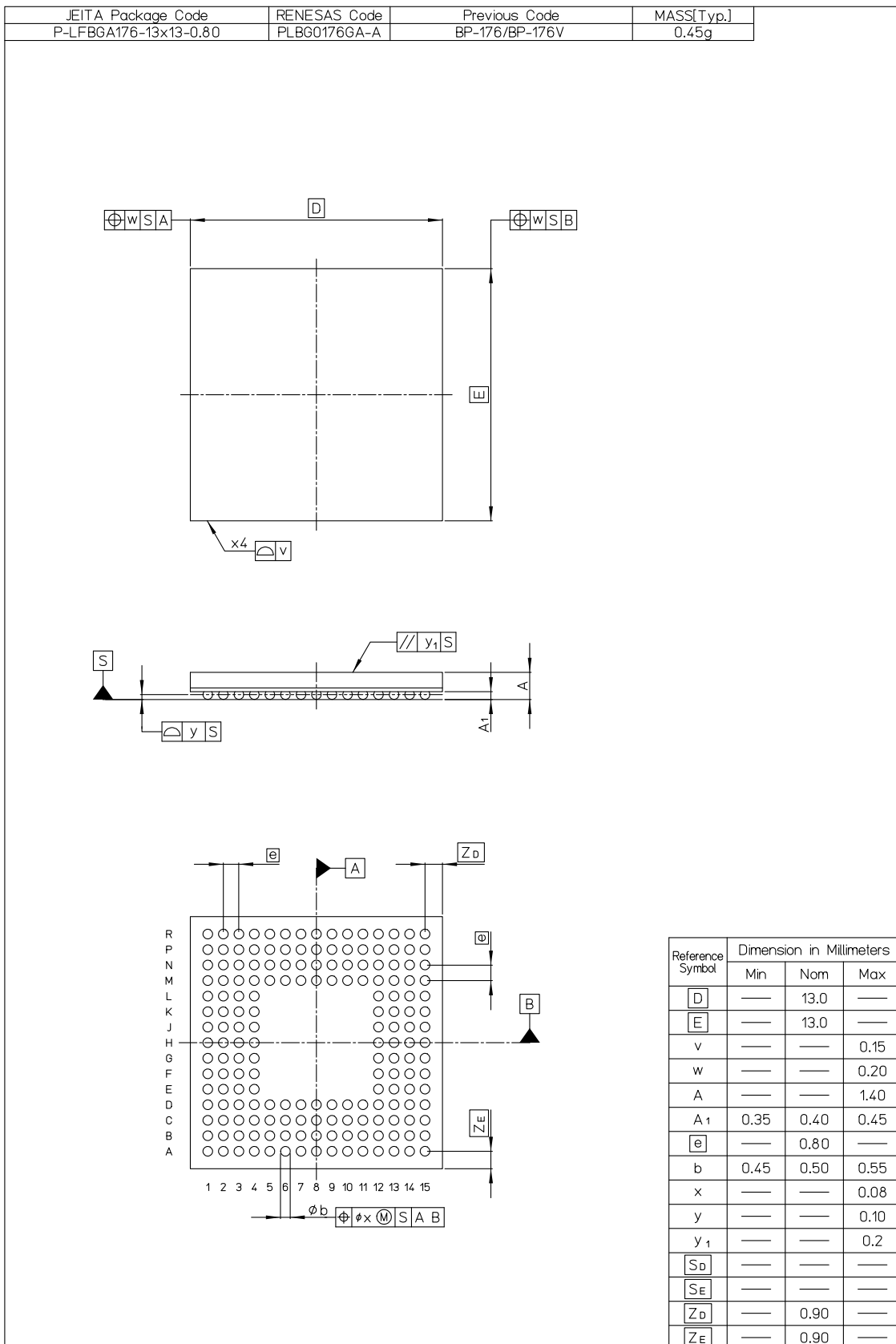

Figure B 176-Pin LFBGA (PLBG0176GA-A)



Figure C 176-Pin LQFP (PLQP0176KB-A)



Figure D 145-Pin TFLGA (PTLG0145KA-A)



Figure E 144-Pin LQFP (PLQP0144KA-A)



Figure F 100-Pin TFLGA (PTLG0100JA-A)



Figure G 100-Pin LQFP (PLQP0100KB-A)

REVISION HISTORY	RX71M Group User's Manual: Datasheet
------------------	--------------------------------------

Classifications

- Items with Technical Update document number: Changes according to the corresponding issued Technical Update
- Items without Technical Update document number: Minor changes that do not require Technical Update to be issued

Rev.	Date	Description		Classification
		Page	Summary	
1.00	Jan 15, 2015	—	First edition, issued	
1.10	Dec 28, 2017	All	Terms unified: GPTa → GPTA LQFP → LFQFP	
		Features		
		1	AES key lengths, changed	TN-RX*-A122A/E
		1. Overview		
		2	Table 1.1 Outline of Specifications (1/9), changed	TN-RX*-A127A/E
		5	Table 1.1 Outline of Specifications (4/9), changed	
		8	Table 1.1 Outline of Specifications (7/9), changed	
		9	Table 1.1 Outline of Specifications (8/9), changed	
		10	Table 1.1 Outline of Specifications (9/9), changed	TN-RX*-A122A/E
		23	Table 1.4 Pin Functions (6/8), changed	
		48	Table 1.7 List of Pin and Pin Functions (145-Pin TFLGA) (2/5), changed	TN-RX*-A122A/E
		52	Table 1.8 List of Pin and Pin Functions (144-Pin LFQFP) (1/5), changed	
		55	Table 1.8 List of Pin and Pin Functions (144-Pin LFQFP) (4/5), changed	
		58	Table 1.9 List of Pin and Pin Functions (100-Pin TFLGA) (2/4), changed	
		63	Table 1.10 List of Pin and Pin Functions (100-Pin LFQFP) (3/4), changed	
		4. I/O Registers		
		108	Table 4.1 List of I/O Registers (Address Order) (37 / 70) 0008 C296h, added	
		110	Table 4.1 List of I/O Registers (Address Order) (39 / 70), changed	TN-RX*-A152A/E
		111	Table 4.1 List of I/O Registers (Address Order) (40 / 70), changed	
		112	Table 4.1 List of I/O Registers (Address Order) (41 / 70), changed	
		134, 135	Table 4.1 List of I/O Registers (Address Order) (63 / 70) (64 / 70), changed	
		142	Table 4.1 List of I/O Registers (Address Order), Note 6 added	TN-RX*-A152A/E
		5. Electrical Characteristics		
		143	Table 5.1 Absolute Maximum Rating, changed	TN-RX*-A160A/E TN-RX*-A178A/E
		143	Table 5.2 Recommended Operating Conditions, added	TN-RX*-A178A/E
		144	Table 5.3 DC Characteristics (1), changed	TN-RX*-A159A/E TN-RX*-A160A/E TN-RX*-A178A/E
		145	Table 5.4 DC Characteristics (2), changed	TN-RX*-A159A/E
148	Table 5.7 Thermal Resistances (Reference), added	TN-RX*-A178A/E		
187	Figure 5.48 RSPI Timing (Master, CPHA = 0) (Bit Rate: PCLKA Division Ratio Set to 1/2), changed	TN-RX*-A159A/E		
208	Figure 5.82 Test Circuit (High-Speed), changed			
211	Table 5.52 Temperature Sensor Characteristics, changed	TN-RX*-A159A/E		
217	Figure 5.88 Battery Backup Function Characteristics, changed			
218	Table 5.56 Code Flash Memory Characteristics, changed	TN-RX*-A146A/E		
219	Table 5.57 Data Flash Memory Characteristics, changed			

All trademarks and registered trademarks are the property of their respective owners.

General Precautions in the Handling of Microprocessing Unit and Microcontroller Unit Products

The following usage notes are applicable to all Microprocessing unit and Microcontroller unit products from Renesas. For detailed usage notes on the products covered by this document, refer to the relevant sections of the document as well as any technical updates that have been issued for the products.

1. Handling of Unused Pins

Handle unused pins in accordance with the directions given under Handling of Unused Pins in the manual.

¾ The input pins of CMOS products are generally in the high-impedance state. In operation with an unused pin in the open-circuit state, extra electromagnetic noise is induced in the vicinity of LSI, an associated shoot-through current flows internally, and malfunctions occur due to the false recognition of the pin state as an input signal become possible. Unused pins should be handled as described under Handling of Unused Pins in the manual.

2. Processing at Power-on

The state of the product is undefined at the moment when power is supplied.

¾ The states of internal circuits in the LSI are indeterminate and the states of register settings and pins are undefined at the moment when power is supplied.

In a finished product where the reset signal is applied to the external reset pin, the states of pins are not guaranteed from the moment when power is supplied until the reset process is completed. In a similar way, the states of pins in a product that is reset by an on-chip power-on reset function are not guaranteed from the moment when power is supplied until the power reaches the level at which resetting has been specified.

3. Prohibition of Access to Reserved Addresses

Access to reserved addresses is prohibited.

¾ The reserved addresses are provided for the possible future expansion of functions. Do not access these addresses; the correct operation of LSI is not guaranteed if they are accessed.

4. Clock Signals

After applying a reset, only release the reset line after the operating clock signal has become stable. When switching the clock signal during program execution, wait until the target clock signal has stabilized.

¾ When the clock signal is generated with an external resonator (or from an external oscillator) during a reset, ensure that the reset line is only released after full stabilization of the clock signal. Moreover, when switching to a clock signal produced with an external resonator (or by an external oscillator) while program execution is in progress, wait until the target clock signal is stable.

5. Differences between Products

Before changing from one product to another, i.e. to a product with a different part number, confirm that the change will not lead to problems.

¾ The characteristics of Microprocessing unit or Microcontroller unit products in the same group but having a different part number may differ in terms of the internal memory capacity, layout pattern, and other factors, which can affect the ranges of electrical characteristics, such as characteristic values, operating margins, immunity to noise, and amount of radiated noise. When changing to a product with a different part number, implement a system-evaluation test for the given product.

Notice

1. Descriptions of circuits, software and other related information in this document are provided only to illustrate the operation of semiconductor products and application examples. You are fully responsible for the incorporation or any other use of the circuits, software, and information in the design of your product or system. Renesas Electronics disclaims any and all liability for any losses and damages incurred by you or third parties arising from the use of these circuits, software, or information.
2. Renesas Electronics hereby expressly disclaims any warranties against and liability for infringement or any other disputes involving patents, copyrights, or other intellectual property rights of third parties, by or arising from the use of Renesas Electronics products or technical information described in this document, including but not limited to, the product data, drawing, chart, program, algorithm, application examples.
3. No license, express, implied or otherwise, is granted hereby under any patents, copyrights or other intellectual property rights of Renesas Electronics or others.
4. You shall not alter, modify, copy, or otherwise misappropriate any Renesas Electronics product, whether in whole or in part. Renesas Electronics disclaims any and all liability for any losses or damages incurred by you or third parties arising from such alteration, modification, copy or otherwise misappropriation of Renesas Electronics products.
5. Renesas Electronics products are classified according to the following two quality grades: "Standard" and "High Quality". The intended applications for each Renesas Electronics product depends on the product's quality grade, as indicated below.
"Standard": Computers; office equipment; communications equipment; test and measurement equipment; audio and visual equipment; home electronic appliances; machine tools; personal electronic equipment; and industrial robots etc.
"High Quality": Transportation equipment (automobiles, trains, ships, etc.); traffic control (traffic lights); large-scale communication equipment; key financial terminal systems; safety control equipment; etc.
Renesas Electronics products are neither intended nor authorized for use in products or systems that may pose a direct threat to human life or bodily injury (artificial life support devices or systems, surgical implantations etc.), or may cause serious property damages (space and undersea repeaters; nuclear power control systems; aircraft control systems; key plant systems; military equipment; etc.). Renesas Electronics disclaims any and all liability for any damages or losses incurred by you or third parties arising from the use of any Renesas Electronics product for which the product is not intended by Renesas Electronics.
6. When using the Renesas Electronics products, refer to the latest product information (data sheets, user's manuals, application notes, "General Notes for Handling and Using Semiconductor Devices" in the reliability handbook, etc.), and ensure that usage conditions are within the ranges specified by Renesas Electronics with respect to maximum ratings, operating power supply voltage range, heat radiation characteristics, installation, etc. Renesas Electronics disclaims any and all liability for any malfunctions or failure or accident arising out of the use of Renesas Electronics products beyond such specified ranges.
7. Although Renesas Electronics endeavors to improve the quality and reliability of Renesas Electronics products, semiconductor products have specific characteristics such as the occurrence of failure at a certain rate and malfunctions under certain use conditions. Further, Renesas Electronics products are not subject to radiation resistance design. Please ensure to implement safety measures to guard them against the possibility of bodily injury, injury or damage caused by fire, and social damage in the event of failure or malfunction of Renesas Electronics products, such as safety design for hardware and software including but not limited to redundancy, fire control and malfunction prevention, appropriate treatment for aging degradation or any other appropriate measures by your own responsibility as warranty for your products/system. Because the evaluation of microcomputer software alone is very difficult and not practical, please evaluate the safety of the final products or systems manufactured by you.
8. Please contact a Renesas Electronics sales office for details as to environmental matters such as the environmental compatibility of each Renesas Electronics product. Please investigate applicable laws and regulations that regulate the inclusion or use of controlled substances, including without limitation, the EU RoHS Directive carefully and sufficiently and use Renesas Electronics products in compliance with all these applicable laws and regulations. Renesas Electronics disclaims any and all liability for damages or losses occurring as a result of your noncompliance with applicable laws and regulations.
9. Renesas Electronics products and technologies shall not be used for or incorporated into any products or systems whose manufacture, use, or sale is prohibited under any applicable domestic or foreign laws or regulations. You shall not use Renesas Electronics products or technologies for (1) any purpose relating to the development, design, manufacture, use, stockpiling, etc., of weapons of mass destruction, such as nuclear weapons, chemical weapons, or biological weapons, or missiles (including unmanned aerial vehicles (UAVs)) for delivering such weapons, (2) any purpose relating to the development, design, manufacture, or use of conventional weapons, or (3) any other purpose of disturbing international peace and security, and you shall not sell, export, lease, transfer, or release Renesas Electronics products or technologies to any third party whether directly or indirectly with knowledge or reason to know that the third party or any other party will engage in the activities described above. When exporting, selling, transferring, etc., Renesas Electronics products or technologies, you shall comply with any applicable export control laws and regulations promulgated and administered by the governments of the countries asserting jurisdiction over the parties or transactions.
10. Please acknowledge and agree that you shall bear all the losses and damages which are incurred from the misuse or violation of the terms and conditions described in this document, including this notice, and hold Renesas Electronics harmless, if such misuse or violation results from your resale or making Renesas Electronics products available any third party.
11. This document shall not be reprinted, reproduced or duplicated in any form, in whole or in part, without prior written consent of Renesas Electronics.
12. Please contact a Renesas Electronics sales office if you have any questions regarding the information contained in this document or Renesas Electronics products.
(Note 1) "Renesas Electronics" as used in this document means Renesas Electronics Corporation and also includes its majority-owned subsidiaries.
(Note 2) "Renesas Electronics product(s)" means any product developed or manufactured by or for Renesas Electronics.

(Rev.3.0-1 November 2016)



SALES OFFICES

Renesas Electronics Corporation

<http://www.renesas.com>

Refer to "<http://www.renesas.com/>" for the latest and detailed information.

Renesas Electronics America Inc.

2801 Scott Boulevard Santa Clara, CA 95050-2549, U.S.A.
Tel: +1-408-588-6000, Fax: +1-408-588-6130

Renesas Electronics Canada Limited

9251 Yonge Street, Suite 8309 Richmond Hill, Ontario Canada L4C 9T3
Tel: +1-905-237-2004

Renesas Electronics Europe Limited

Dukes Meadow, Millboard Road, Bourne End, Buckinghamshire, SL8 5FH, U.K
Tel: +44-1628-585-100, Fax: +44-1628-585-900

Renesas Electronics Europe GmbH

Arcadiastrasse 10, 40472 Düsseldorf, Germany
Tel: +49-211-6503-0, Fax: +49-211-6503-1327

Renesas Electronics (China) Co., Ltd.

Room 1709, Quantum Plaza, No.27 ZhiChunLu Haidian District, Beijing 100191, P.R.China
Tel: +86-10-8235-1155, Fax: +86-10-8235-7679

Renesas Electronics (Shanghai) Co., Ltd.

Unit 301, Tower A, Central Towers, 555 Langao Road, Putuo District, Shanghai, P. R. China 200333
Tel: +86-21-2226-0888, Fax: +86-21-2226-0999

Renesas Electronics Hong Kong Limited

Unit 1601-1611, 16/F., Tower 2, Grand Century Place, 193 Prince Edward Road West, Mongkok, Kowloon, Hong Kong
Tel: +852-2265-6688, Fax: +852-2886-9022

Renesas Electronics Taiwan Co., Ltd.

13F, No. 363, Fu Shing North Road, Taipei 10543, Taiwan
Tel: +886-2-8175-9600, Fax: +886-2-8175-9670

Renesas Electronics Singapore Pte. Ltd.

80 Bendemeer Road, Unit #06-02 Hyflux Innovation Centre, Singapore 339949
Tel: +65-6213-0200, Fax: +65-6213-0300

Renesas Electronics Malaysia Sdn.Bhd.

Unit 1207, Block B, Menara Amcorp, Amcorp Trade Centre, No. 18, Jln Persiaran Barat, 46050 Petaling Jaya, Selangor Darul Ehsan, Malaysia
Tel: +60-3-7955-9390, Fax: +60-3-7955-9510

Renesas Electronics India Pvt. Ltd.

No.777C, 100 Feet Road, HAL II Stage, Indiranagar, Bangalore, India
Tel: +91-80-67208700, Fax: +91-80-67208777

Renesas Electronics Korea Co., Ltd.

12F., 234 Teheran-ro, Gangnam-Gu, Seoul, 135-080, Korea
Tel: +82-2-558-3737, Fax: +82-2-558-5141

Mouser Electronics

Authorized Distributor

Click to View Pricing, Inventory, Delivery & Lifecycle Information:

Renesas Electronics:

[R5F571MFC DLC#20](#) [R5F571MFDDFB#V0](#) [R5F571MGDDLJ#20](#) [R5F571MGCDBG#20](#) [R5F571MGGDLC#20](#)
[R5F571MJGDFC#V0](#) [R5F571MLHDLJ#20](#) [R5F571MJCDLJ#20](#) [R5F571MGGDLK#20](#) [R5F571MJDDFC#V0](#)
[R5F571MLDDLJ#20](#) [R5F571MGCDLC#20](#) [R5F571MLGDLJ#20](#) [R5F571MLHDBG#20](#) [R5F571MLGDFC#V0](#)
[R5F571MLDDLJ#20](#) [R5F571MLCDLJ#20](#) [R5F571MGHDLK#20](#) [R5F571MGHDLC#20](#) [R5F571MJGDBG#20](#)
[R5F571MJGDLJ#20](#) [R5F571MJHDLJ#20](#) [R5F571MGCDLK#20](#) [R5F571MFGDFP#V0](#) [R5F571MGHDLJ#20](#)
[R5F571MGHDBG#20](#) [R5F571MFGDLC#20](#) [R5F571MGDDFC#V0](#) [R5F571MGGDFB#V0](#) [R5F571MLDDFB#V0](#)
[R5F571MJCDLK#20](#) [R5F571MFHDLK#20](#) [R5F571MFCDLK#20](#) [R5F571MGCDLJ#20](#) [R5F571MGDDLJ#20](#)
[R5F571MLDDFP#V0](#) [R5F571MLGDLC#20](#) [R5F571MLHDLK#20](#) [R5F571MJDDLK#20](#) [R5F571MFDDLJ#20](#)
[R5F571MJGDFB#V0](#) [R5F571MJGDLK#20](#) [R5F571MLCDLC#20](#) [R5F571MGGDLJ#20](#) [R5F571MJGDFP#V0](#)
[R5F571MLGDFP#V0](#) [R5F571MGDDFP#V0](#) [R5F571MGDDLK#20](#) [R5F571MJCDBG#20](#) [R5F571MFDDBG#20](#)
[R5F571MFDDLK#20](#) [R5F571MFHDBG#20](#) [R5F571MFHDLJ#20](#) [R5F571MGGDFP#V0](#) [R5F571MJDDFB#V0](#)
[R5F571MFGDLK#20](#) [R5F571MFDDFC#V0](#) [R5F571MFHDLC#20](#) [R5F571MJDDLJ#20](#) [R5F571MFCDLJ#20](#)
[R5F571MFCDBG#20](#) [R5F571MFGDLJ#20](#) [R5F571MGDDFB#V0](#) [R5F571MGGDBG#20](#) [R5F571MLDDFC#V0](#)
[R5F571MLGDBG#20](#) [R5F571MLGDFB#V0](#) [R5F571MJGDLK#20](#) [R5F571MJHDBG#20](#) [R5F571MGGDFC#V0](#)
[R5F571MJHDLK#20](#) [R5F571MLCDLK#20](#) [R5F571MLDDBG#20](#) [R5F571MJCDLC#20](#) [R5F571MFGDFB#V0](#)
[R5F571MFDDFP#V0](#) [R5F571MFGDFC#V0](#) [R5F571MFDDLJ#20](#) [R5F571MGDDBG#20](#) [R5F571MLDDLK#20](#)
[R5F571MJDDLJ#20](#) [R5F571MLHDLK#20](#) [R5F571MFGDBG#20](#) [R5F571MLCDBG#20](#) [R5F571MJHDLK#20](#)
[R5F571MLGDLK#20](#) [R5F571MJDDBG#20](#) [R5F571MJDDFP#V0](#) [R5F571MFDDFP#30](#) [R5F571MGCDFB#30](#)
[R5F571MGCDFP#30](#) [R5F571MGDDFB#30](#) [R5F571MGDDFP#30](#) [R5F571MJCDFB#30](#) [R5F571MFDDFB#30](#)
[R5F571MFCDFP#30](#) [R5F571MFCDFB#30](#) [R5F571MJCDFP#30](#) [R5F571MJDDFB#30](#) [R5F571MJDDFP#30](#)



Компания «ЭлектроПласт» предлагает заключение долгосрочных отношений при поставках импортных электронных компонентов на взаимовыгодных условиях!

Наши преимущества:

- Оперативные поставки широкого спектра электронных компонентов отечественного и импортного производства напрямую от производителей и с крупнейших мировых складов;
- Поставка более 17-ти миллионов наименований электронных компонентов;
- Поставка сложных, дефицитных, либо снятых с производства позиций;
- Оперативные сроки поставки под заказ (от 5 рабочих дней);
- Экспресс доставка в любую точку России;
- Техническая поддержка проекта, помощь в подборе аналогов, поставка прототипов;
- Система менеджмента качества сертифицирована по Международному стандарту ISO 9001;
- Лицензия ФСБ на осуществление работ с использованием сведений, составляющих государственную тайну;
- Поставка специализированных компонентов (Xilinx, Altera, Analog Devices, Intersil, Interpoint, Microsemi, Aeroflex, Peregrine, Syfer, Eurofarad, Texas Instrument, Miteq, Cobham, E2V, MA-COM, Hittite, Mini-Circuits, General Dynamics и др.);

Помимо этого, одним из направлений компании «ЭлектроПласт» является направление «Источники питания». Мы предлагаем Вам помощь Конструкторского отдела:

- Подбор оптимального решения, техническое обоснование при выборе компонента;
- Подбор аналогов;
- Консультации по применению компонента;
- Поставка образцов и прототипов;
- Техническая поддержка проекта;
- Защита от снятия компонента с производства.



Как с нами связаться

Телефон: 8 (812) 309 58 32 (многоканальный)

Факс: 8 (812) 320-02-42

Электронная почта: org@eplast1.ru

Адрес: 198099, г. Санкт-Петербург, ул. Калинина, дом 2, корпус 4, литера А.