

The S-5840B Series is a temperature switch IC (thermostat IC) with a latch function which detects the temperature with a temperature accuracy of  $\pm 2.5^{\circ}\text{C}$ . When the temperature reaches the detection temperature, the output signal is inverted and being latched until the S-5840B Series detects decrease in a power supply voltage.

The S-5840B Series operates at the lower power supply voltage of 1.0 V and its current consumption is 12  $\mu\text{A}$  typ. due to CMOS configuration.

The S-5840B Series has a temperature sensor using negative temperature coefficient, a reference voltage generation circuit, comparator, voltage detection circuit and noise suppression circuit on a chip, and they are enclosed in package SOT-23-5.

## ■ Features

- Detection temperature:  $T_{\text{DET}} = +55$  to  $+95^{\circ}\text{C}$ ,  $+1^{\circ}\text{C}$  step, detection accuracy:  $\pm 2.5^{\circ}\text{C}$
- Wide voltage operation:  $V_{\text{DD}} = 1.0$  V to 10.0 V
- Release voltage:  $V_{\text{RET}} = 2.2$  V to 3.4 V, 0.1 V step
- Low current consumption:  $I_{\text{DD}} = 12$   $\mu\text{A}$  typ. ( $T_{\text{a}} = +25^{\circ}\text{C}$ ).
- Built-in noise suppression circuit for preventing temperature detection malfunction
- Output logic level is fixed by the latch after temperature detection.
- Selectable output logic in active "H" or "L"
- Selectable output form in CMOS or Nch open drain
- Operation temperature range:  $T_{\text{a}} = -40^{\circ}\text{C}$  to  $+100^{\circ}\text{C}$
- Lead-free, Sn 100%, halogen-free<sup>\*1</sup>

\*1. Refer to "■ Product Name Structure" for details.

## ■ Applications

- Game console
- Electronic device

## ■ Package

- SOT-23-5

■ Block Diagrams

1. CMOS output product

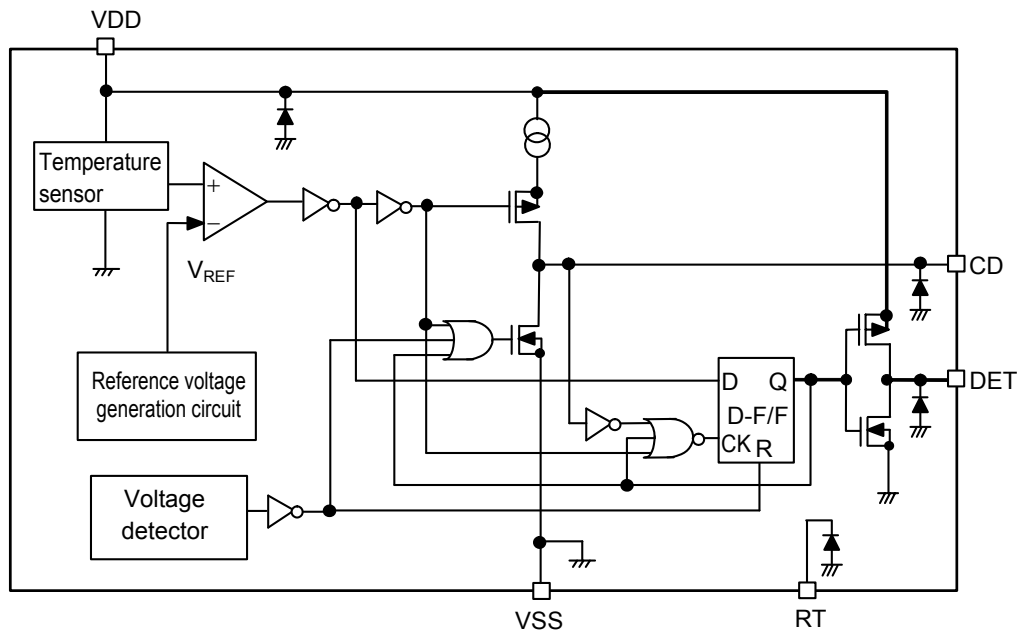

Figure 1

2. Nch open drain output product

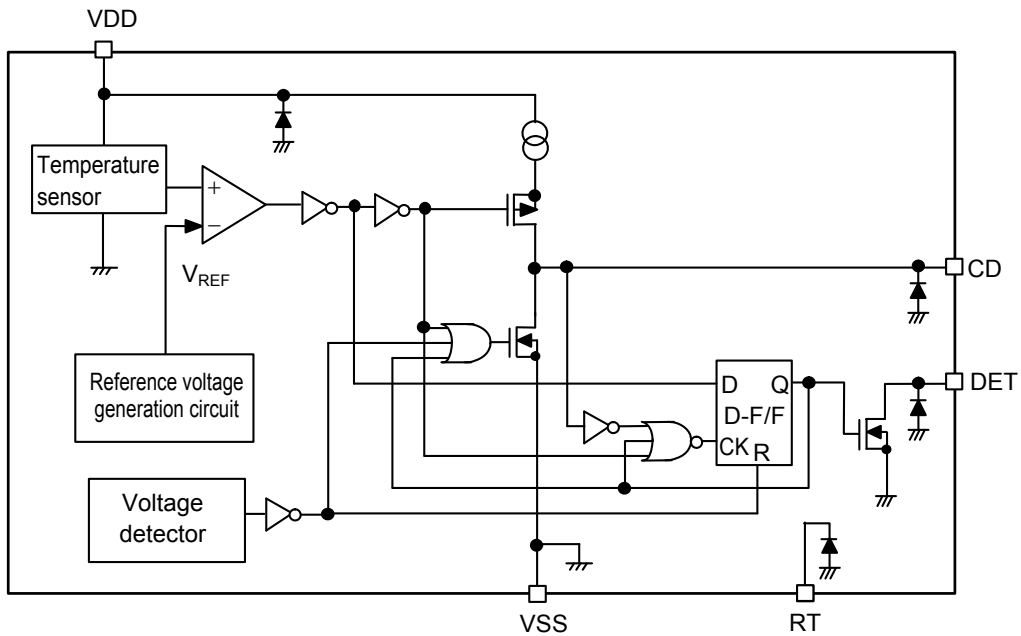
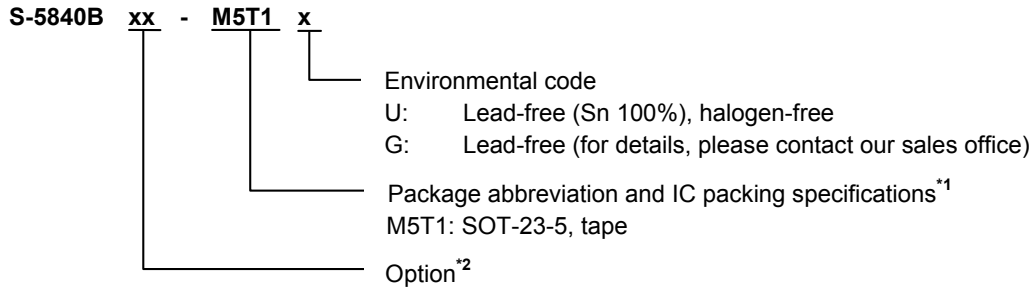

Figure 2

■ **Product Name Structure**

Users are able to select the option for detection temperature, output form and logic, release voltage for the S-5840B Series.

**1. Product name**



\*1. Refer to the tape drawing.

\*2. Option list

- The detection temperature ( $T_{DET}$ ) can be set in the range of +55°C to +95° at 1°C step.
- The DET pin output can be selected the output logic in active "H" or "L".
- The DET pin output can be selected the output form in CMOS or Nch open drain.
- The release voltage ( $V_{RET}$ ) can be set in the range of 2.2 V to 3.4 V at 0.1 V step.

**2. Package**

**Table 1   Package Drawing Codes**

Package Name	Dimension	Tape	Reel
SOT-23-5	MP005-A-P-SD	MP005-A-C-SD	MP005-A-R-SD

**3. Product name list**

**Table 2**

Product Name	Detection Temperature ( $T_{DET}$ )	DET Pin Output Form	DET Pin Output Logic	Release Voltage ( $V_{RET}$ )
S-5840BAG-M5T1x	+60°C	CMOS	Active "L"	2.9 V
S-5840BAH-M5T1x	+90°C	CMOS	Active "H"	2.9 V
S-5840BAJ-M5T1x	+80°C	Nch open drain	Active "L"	2.2 V

**Remark 1.** Please contact our sales office for options other than that specified above.

**2.** x: G or U

**3.** Please select products of environmental code = U for Sn 100%, halogen-free products.

■ Pin Configuration

1. SOT-23-5

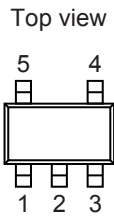

Figure 3

Table 3

Pin No.	Symbol	Description
1	RT <sup>*1</sup>	Test pin
2	VSS	GND pin
3	CD	Capacitor connection pin for setting malfunction prevention time
4	DET	Output pin
5	VDD	Power supply pin

\*1. Set the RT pin open in use.

■ **Absolute Maximum Ratings**

Table 4

(Ta = +25°C unless otherwise specified)

Item		Symbol	Absolute Maximum Rating	Unit
Power supply voltage (V <sub>SS</sub> = 0 V)		V <sub>DD</sub>	V <sub>SS</sub> + 12	V
Pin voltage		V <sub>RT</sub> , V <sub>CD</sub>	V <sub>SS</sub> - 0.3 to V <sub>DD</sub> + 0.3	V
Output voltage	CMOS output	V <sub>DET</sub>	V <sub>SS</sub> - 0.3 to V <sub>DD</sub> + 0.3	V
	Nch open drain output		V <sub>SS</sub> - 0.3 to V <sub>SS</sub> + 12.0	V
Power dissipation		P <sub>D</sub>	300 (when not mounted on board)	mW
			600*1	mW
Operating temperature		T <sub>opr</sub>	-40 to +100	°C
Storage temperature		T <sub>stg</sub>	-55 to +125	°C

\*1. When mounted on board

[Mounted board]

(1) Board size: 114.3 mm × 76.2 mm × t1.6 mm

(2) Board name: JEDEC STANDARD51-7

**Caution** The absolute maximum ratings are rated values exceeding which the product could suffer physical damage. These values must therefore not be exceeded under any conditions.

■ **Recommended Values for External Parts**

Table 5

Item	Symbol	Value	Unit
CD capacitance	C <sub>D</sub>	4.7	nF

■ DC Electrical Characteristics

1. CMOS output product

Table 6

(Ta = +25°C, unless otherwise specified)

Item	Symbol	Condition	Min.	Typ.	Max.	Unit	Test Circuit
Power supply voltage	V <sub>DD</sub>	–	1.0	–	10.0	V	1
Detection temperature	+T <sub>D</sub>	–	T <sub>DET</sub> – 2.5	T <sub>DET</sub>	T <sub>DET</sub> + 2.5	°C	1
Output current	I <sub>DETH</sub>	V <sub>DD</sub> = 3.5 V, Apply to DET pin V <sub>DET</sub> = 2.7 V	2	9.4	–	mA	2
	I <sub>DETL</sub>		0.5	2.8	–	mA	2
Release voltage for built-in voltage detector	V <sub>R</sub>	–	V <sub>RET</sub> × 0.98	V <sub>RET</sub>	V <sub>RET</sub> × 1.02	V	–
Hysteresis width for built-in voltage detector	V <sub>HYS</sub>	–	–	V <sub>RET</sub> × 0.05	–	V	–
Temperature coefficient for built-in voltage detector	$\frac{\Delta V_{RET}}{\Delta Ta \cdot V_{RET}}$	Ta = –40°C to +100°C	–	±100	–	ppm/°C	–
Current consumption during operation	I <sub>DD</sub>	V <sub>DD</sub> = 3.5 V	–	12	24	μA	1

2. Nch open drain output product

Table 7

(Ta = +25°C, unless otherwise specified)

Item	Symbol	Condition	Min.	Typ.	Max.	Unit	Test Circuit
Power supply voltage	V <sub>DD</sub>	–	1.0	–	10.0	V	1
Detection temperature	+T <sub>D</sub>	–	T <sub>DET</sub> – 2.5	T <sub>DET</sub>	T <sub>DET</sub> + 2.5	°C	1
Output current	I <sub>DETL</sub>	V <sub>DET</sub> = 0.4 V, V <sub>DD</sub> = 3.5 V	0.5	2.8	–	mA	2
	I <sub>LEAK</sub>	V <sub>DET</sub> = 10.0 V, V <sub>DD</sub> = 3.5 V	–	–	100	nA	2
Release voltage for built-in voltage detector	V <sub>R</sub>	–	V <sub>RET</sub> × 0.98	V <sub>RET</sub>	V <sub>RET</sub> × 1.02	V	–
Hysteresis width for built-in voltage detector	V <sub>HYS</sub>	–	–	V <sub>RET</sub> × 0.05	–	V	–
Temperature coefficient for built-in voltage detector	$\frac{\Delta V_{RET}}{\Delta Ta \cdot V_{RET}}$	Ta = –40°C to +100°C	–	±100	–	ppm/°C	–
Current consumption during operation	I <sub>DD</sub>	V <sub>DD</sub> = 3.5 V	–	12	24	μA	1

■ AC Electrical Characteristics

Table 8

Item	Symbol	Condition	Min.	Typ.	Max.	Unit	Test Circuit
Noise suppression time	t <sub>noise</sub>	C <sub>D</sub> = 4.7 nF, V <sub>DD</sub> = 3.5 V, Ta = detection temperature	10	30	50	ms	–

■ **Test Circuits**

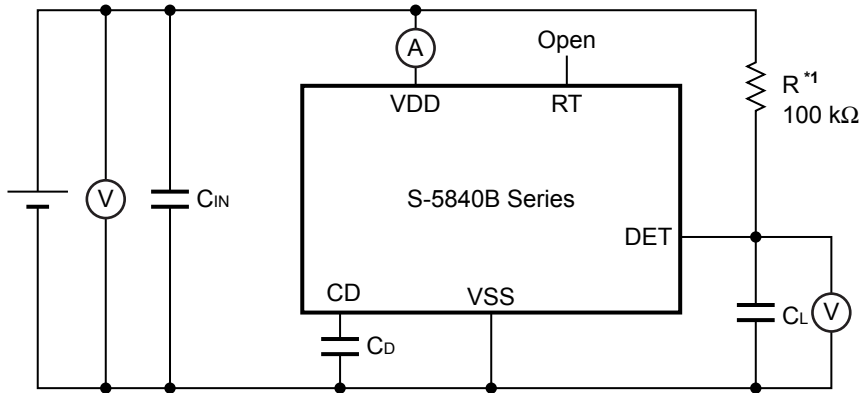

\*1. Resistor (R) is unnecessary for the CMOS output product.

**Figure 4 Test Circuit 1**

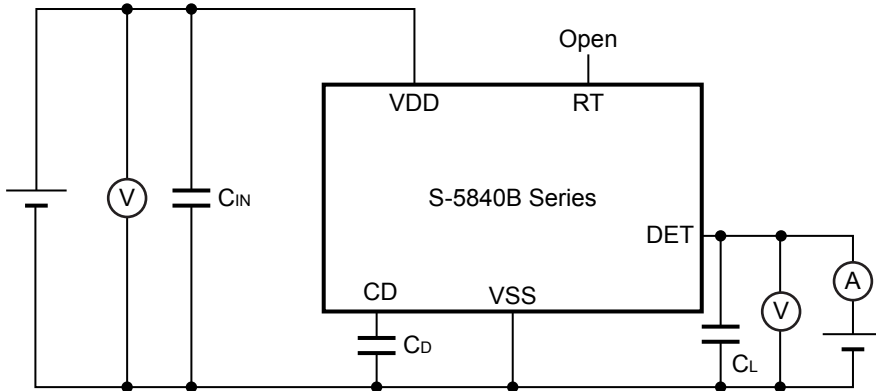

**Figure 5 Test Circuit 2**

## ■ Operation

### 1. Basic operation

The S-5840B Series is a temperature switch IC (thermostat IC) which detects the temperature and sends a signal to an external device. The users can select a combination of the parameters such as detection temperature and release voltage.

Following is about the operation when the DET pin output logic is active "H".

When the power supply voltage is turned on, the DET pin voltage goes to "L" since the flip-flop circuit in the detection circuit is cleared by the voltage detection circuit. Temperature detection then starts and the DET pin is held "L" as long as the temperature is lower than the detection temperature. When the temperature rises and when the temperature exceeds the detection temperature; longer than the time defined by the capacitor connected to the CD pin, the DET pin goes to "H". Once the over-temperature is detected and the DET pin goes to "H", the state is held by the flip-flop circuit. In order to release the state, the power supply voltage should be set under the detection voltage ( $V_R - V_{HYS}$ ) of the built-in voltage detector circuit to reset the internal circuit.

Using the internal reference voltage and built-in temperature sensor, a detection temperature accuracy of  $\pm 2.5^\circ\text{C}$  is achieved in the S-5840B Series.

### 2. Noise suppression circuit

The noise suppression circuit prevents malfunction of the temperature switch caused by noise.

The noise suppression circuit starts charging the capacitor connected to the CD pin when the output of the internal comparator enters the active state due to an external noise or a rapid change in the power supply voltage. In the normal operation, the flip-flop circuit is set when the capacitor is charged to a certain voltage. But in the noise triggered operation, the comparator output goes back to the inactive state and the CD pin voltage is held "L" since the charging of the external capacitor ( $C_D$ ) is insufficient. As a result, the DET pin is held "L" and malfunction does not occur.

Noise suppression time ( $t_{\text{noise}}$ ) is determined by the time constant consisting of internal constant current and the capacitance of the  $C_D$ , and calculated by the following equation.

$$t_{\text{noise}} (\text{ms}) = \text{Noise suppression time coefficient} \times C_D (\text{nF})$$

Noise suppression time coefficient ( $T_a = +25^\circ\text{C}$ ): 6.4 typ.

The  $C_D$  has no limitation as long as its leak current is negligible compared to the internal constant current. The difference occurs in delay time if the capacitor has a leak current.



■ **Standard Circuit**

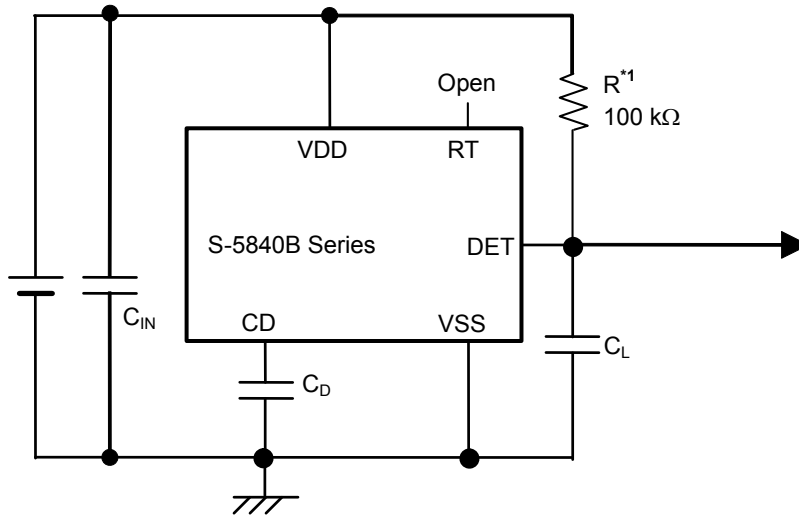

\*1. Resistor (R) is unnecessary for the CMOS output product.

**Figure 6**

**Caution** The above connection diagram will not guarantee successful operation. Perform thorough evaluation using actual application to set the constant.

■ **Precautions**

- Set a capacitor ( $C_{IN}$ ) of 0.1  $\mu\text{F}$  or more between VDD and VSS pin for stabilization.
- A capacitor ( $C_L$ ) of about 1  $\mu\text{F}$  should be connected to the DET pin to prevent malfunction caused by noise due to the power being on.
- Do not connect a capacitor to the RT pin (leave the RT pin open). Otherwise, this IC may oscillate.
- Do not apply an electrostatic discharge to this IC that exceeds the performance ratings of the built-in electrostatic protection circuit.
- ABLIC Inc. claims no responsibility for any disputes arising out of or in connection with any infringement by products, including this IC, of patents owned by a third party.

■ Characteristics (Typical Data)

1. Current consumption vs. Power supply voltage characteristics

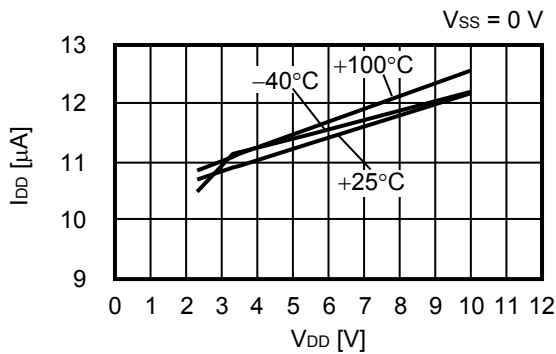

2. DET pin current "H" vs. Power supply voltage characteristics (CMOS output product only)

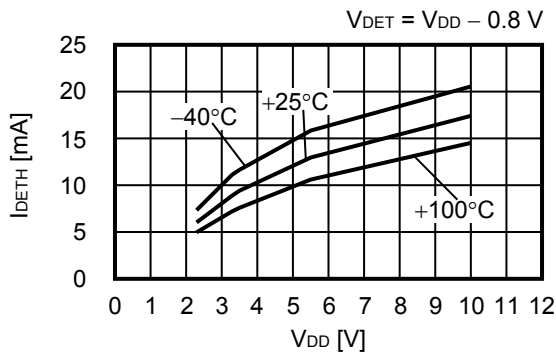

3. DET pin current "L" vs. Power supply voltage characteristics

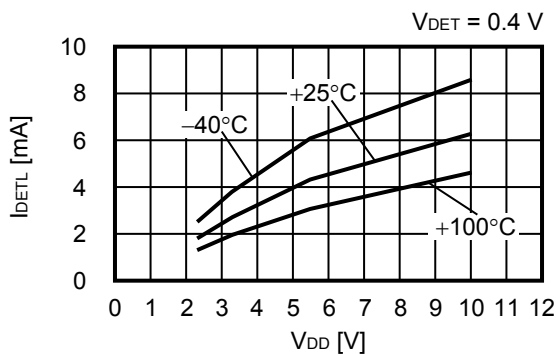

4. Noise suppression time vs. Power supply voltage characteristics

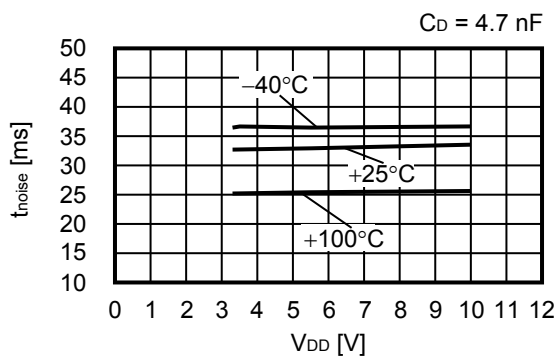

■ **Marking Specification**

**1. SOT-23-5**

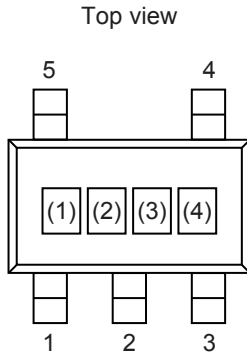

(1) to (3): Product code (refer to Product name vs. Product code)  
 (4): Lot number

**Product name vs. Product code**

Product Name	Product Code		
	(1)	(2)	(3)
S-5840BAG-M5T1x	H	8	M
S-5840BAH-M5T1x	H	8	N
S-5840BAJ-M5T1x	H	8	O

**Remark 1.** x: G or U

**2.** Please select products of environmental code = U for Sn 100%, halogen-free products.



No. MP005-A-P-SD-1.3

TITLE	SOT235-A-PKG Dimensions
No.	MP005-A-P-SD-1.3
ANGLE	
UNIT	mm
<b>ABLIC Inc.</b>	



→ Feed direction

No. MP005-A-C-SD-2.1

TITLE	SOT235-A-Carrier Tape
No.	MP005-A-C-SD-2.1
ANGLE	
UNIT	mm

**ABLIC Inc.**



Enlarged drawing in the central part



No. MP005-A-R-SD-1.1

TITLE	SOT235-A-Reel		
No.	MP005-A-R-SD-1.1		
ANGLE		QTY.	3,000
UNIT	mm		
<b>ABLIC Inc.</b>			

## Disclaimers (Handling Precautions)

1. All the information described herein (product data, specifications, figures, tables, programs, algorithms and application circuit examples, etc.) is current as of publishing date of this document and is subject to change without notice.
2. The circuit examples and the usages described herein are for reference only, and do not guarantee the success of any specific mass-production design.  
ABLIC Inc. is not responsible for damages caused by the reasons other than the products described herein (hereinafter "the products") or infringement of third-party intellectual property right and any other right due to the use of the information described herein.
3. ABLIC Inc. is not responsible for damages caused by the incorrect information described herein.
4. Be careful to use the products within their specified ranges. Pay special attention to the absolute maximum ratings, operation voltage range and electrical characteristics, etc.  
ABLIC Inc. is not responsible for damages caused by failures and / or accidents, etc. that occur due to the use of the products outside their specified ranges.
5. When using the products, confirm their applications, and the laws and regulations of the region or country where they are used and verify suitability, safety and other factors for the intended use.
6. When exporting the products, comply with the Foreign Exchange and Foreign Trade Act and all other export-related laws, and follow the required procedures.
7. The products must not be used or provided (exported) for the purposes of the development of weapons of mass destruction or military use. ABLIC Inc. is not responsible for any provision (export) to those whose purpose is to develop, manufacture, use or store nuclear, biological or chemical weapons, missiles, or other military use.
8. The products are not designed to be used as part of any device or equipment that may affect the human body, human life, or assets (such as medical equipment, disaster prevention systems, security systems, combustion control systems, infrastructure control systems, vehicle equipment, traffic systems, in-vehicle equipment, aviation equipment, aerospace equipment, and nuclear-related equipment), excluding when specified for in-vehicle use or other uses. Do not apply the products to the above listed devices and equipments without prior written permission by ABLIC Inc. Especially, the products cannot be used for life support devices, devices implanted in the human body and devices that directly affect human life, etc.  
Prior consultation with our sales office is required when considering the above uses.  
ABLIC Inc. is not responsible for damages caused by unauthorized or unspecified use of our products.
9. Semiconductor products may fail or malfunction with some probability.  
The user of the products should therefore take responsibility to give thorough consideration to safety design including redundancy, fire spread prevention measures, and malfunction prevention to prevent accidents causing injury or death, fires and social damage, etc. that may ensue from the products' failure or malfunction.  
The entire system must be sufficiently evaluated and applied on customer's own responsibility.
10. The products are not designed to be radiation-proof. The necessary radiation measures should be taken in the product design by the customer depending on the intended use.
11. The products do not affect human health under normal use. However, they contain chemical substances and heavy metals and should therefore not be put in the mouth. The fracture surfaces of wafers and chips may be sharp. Be careful when handling these with the bare hands to prevent injuries, etc.
12. When disposing of the products, comply with the laws and ordinances of the country or region where they are used.
13. The information described herein contains copyright information and know-how of ABLIC Inc.  
The information described herein does not convey any license under any intellectual property rights or any other rights belonging to ABLIC Inc. or a third party. Reproduction or copying of the information from this document or any part of this document described herein for the purpose of disclosing it to a third-party without the express permission of ABLIC Inc. is strictly prohibited.
14. For more details on the information described herein, contact our sales office.

2.2-2018.06

# Mouser Electronics

Authorized Distributor

Click to View Pricing, Inventory, Delivery & Lifecycle Information:

[ABLIC:](#)

[S-5840BAG-M5T1G](#) [S-5840BAH-M5T1G](#) [S-5840BAJ-M5T1G](#) [S-5840BAN-M5T1U](#)





Компания «ЭлектроПласт» предлагает заключение долгосрочных отношений при поставках импортных электронных компонентов на взаимовыгодных условиях!

Наши преимущества:

- Оперативные поставки широкого спектра электронных компонентов отечественного и импортного производства напрямую от производителей и с крупнейших мировых складов;
- Поставка более 17-ти миллионов наименований электронных компонентов;
- Поставка сложных, дефицитных, либо снятых с производства позиций;
- Оперативные сроки поставки под заказ (от 5 рабочих дней);
- Экспресс доставка в любую точку России;
- Техническая поддержка проекта, помощь в подборе аналогов, поставка прототипов;
- Система менеджмента качества сертифицирована по Международному стандарту ISO 9001;
- Лицензия ФСБ на осуществление работ с использованием сведений, составляющих государственную тайну;
- Поставка специализированных компонентов (Xilinx, Altera, Analog Devices, Intersil, Interpoint, Microsemi, Aeroflex, Peregrine, Syfer, Eurofarad, Texas Instrument, Miteq, Cobham, E2V, MA-COM, Hittite, Mini-Circuits, General Dynamics и др.);

Помимо этого, одним из направлений компании «ЭлектроПласт» является направление «Источники питания». Мы предлагаем Вам помощь Конструкторского отдела:

- Подбор оптимального решения, техническое обоснование при выборе компонента;
- Подбор аналогов;
- Консультации по применению компонента;
- Поставка образцов и прототипов;
- Техническая поддержка проекта;
- Защита от снятия компонента с производства.



#### Как с нами связаться

**Телефон:** 8 (812) 309 58 32 (многоканальный)

**Факс:** 8 (812) 320-02-42

**Электронная почта:** [org@eplast1.ru](mailto:org@eplast1.ru)

**Адрес:** 198099, г. Санкт-Петербург, ул. Калинина, дом 2, корпус 4, литера А.