



SANYO Semiconductors

DATA SHEET

An ON Semiconductor Company

LV8712T — Bi-CMOS LSI PWM Constant-Current Control Stepping Motor Driver

Overview

The LV8712T is a stepping motor driver of the micro-step drive corresponding to supports 2W 1-2 phase excitation. It is the best for the drive of the stepping motor for a scanner and a small printer.

Features

- Single-channel PWM constant-current control stepping motor driver incorporated.
- Excitation mode can be set to 2-phase, 1-2 phase, W1-2 phase, or 2W1-2 phase
- Microstep can control easily by the CLK-IN input.
- Power-supply voltage of motor : VM max = 18V
- Output current : IO max = 0.8A
- Output ON resistance : RON = 1.1Ω (upper and lower total, typical, Ta = 25°C)
- A thermal shutdown circuit and a low voltage detecting circuit are built into.

Specifications

Absolute Maximum Ratings at Ta = 25°C

Parameter	Symbol	Conditions	Ratings	Unit
Motor supply voltage	VM max		18	V
Logic supply voltage	VCC max		6	V
Output peak current	IO peak	Each 1ch, tw ≤ 10ms, duty 20%	1.0	A
Output continuous current	IO max	Each 1ch	800	mA
Logic input voltage	VIN		-0.3 to VCC + 0.3	V
Allowable power dissipation	Pd max	*	1.35	W
Operating temperature	Topr		-20 to +85	°C
Storage temperature	Tstg		-55 to +150	°C

* Specified circuit board : 57.0mm×57.0mm×1.7mm, glass epoxy 2-layer board.

■ Any and all SANYO Semiconductor Co.,Ltd. products described or contained herein are, with regard to "standard application", intended for the use as general electronics equipment (home appliances, AV equipment, communication device, office equipment, industrial equipment etc.). The products mentioned herein shall not be intended for use for any "special application" (medical equipment whose purpose is to sustain life, aerospace instrument, nuclear control device, burning appliances, transportation machine, traffic signal system, safety equipment etc.) that shall require extremely high level of reliability and can directly threaten human lives in case of failure or malfunction of the product or may cause harm to human bodies, nor shall they grant any guarantee thereof. If you should intend to use our products for applications outside the standard applications of our customer who is considering such use and/or outside the scope of our intended standard applications, please consult with us prior to the intended use. If there is no consultation or inquiry before the intended use, our customer shall be solely responsible for the use.

■ Specifications of any and all SANYO Semiconductor Co.,Ltd. products described or contained herein stipulate the performance, characteristics, and functions of the described products in the independent state, and are not guarantees of the performance, characteristics, and functions of the described products as mounted in the customer's products or equipment. To verify symptoms and states that cannot be evaluated in an independent device, the customer should always evaluate and test devices mounted in the customer's products or equipment.

LV8712T

Allowable Operating Ratings at Ta = 25°C

Parameter	Symbol	Conditions	Ratings	Unit
Motor supply voltage range	VM		4 to 16	V
Logic supply voltage range	VCC		2.7 to 5.5	V
Logic input voltage	VIN		-0.3 to VCC+0.3	V
VREF input voltage range	VREF		0 to VCC-1.8	V

Electrical Characteristics at Ta = 25°C, VM = 12V, VCC = 3.3V, VREF = 1.0V

Parameter	Symbol	Conditions	Ratings			Unit	
			min	typ	max		
Standby mode current drain	IMstn	PS = "L", no load			1	μA	
	ICCstn	PS = "L", no load			1	μA	
Current drain	IM	PS = "H", no load	0.3	0.5	0.7	mA	
	ICC	PS = "H", no load	0.9	1.3	1.7	mA	
Thermal shutdown temperature	TSD	Design guarantee		180		°C	
Thermal hysteresis width	ΔTSD	Design guarantee		40		°C	
VCC low voltage cutting voltage	VthVCC		2.1	2.4	2.7	V	
Low voltage hysteresis voltage	VthHIS		100	130	160	mV	
REG5 output voltage	Vreg5	IO = -1mA	4.5	5	5.5	V	
Output on resistance	RonU	IO = -800mA, Source-side on resistance		0.78	1.0	Ω	
	RonD	IO = 800mA, Sink-side on resistance		0.32	0.43	Ω	
Output leakage current	IOleak	VO = 15V			10	μA	
Diode forward voltage	VD	ID = -800mA		1.0	1.2	V	
Logic pin input current	IINL	VIN = 0.8V	4	8	12	μA	
	IINH	VIN = 3.3V	22	33	45	μA	
Logic high-level input voltage	VINH		2.0			V	
Logic low-level input voltage	VINL				0.8	V	
VREF input current	IREF	VREF = 1.0V	-0.5			μA	
Current setting comparator threshold voltage (current step switching)	2W1-2-phase drive	Vtdac0_2W	Step 0 (When initialized : channel 1 comparator level)	0.191	0.2	0.209	V
		Vtdac1_2W	Step 1 (Initial state+1)	0.187	0.196	0.205	V
		Vtdac2_2W	Step 2 (Initial state+2)	0.175	0.184	0.193	V
		Vtdac3_2W	Step 3 (Initial state+3)	0.158	0.166	0.174	V
		Vtdac4_2W	Step 4 (Initial state+4)	0.132	0.140	0.148	V
		Vtdac5_2W	Step 5 (Initial state+5)	0.102	0.110	0.118	V
		Vtdac6_2W	Step 6 (Initial state+6)	0.068	0.076	0.084	V
	W1-2-phase drive	Vtdac0_W	Step 0 (When initialized : channel 1 comparator level)	0.191	0.200	0.209	V
		Vtdac2_W	Step 2 (Initial state+1)	0.175	0.184	0.193	V
		Vtdac4_W	Step 4 (Initial state+2)	0.132	0.140	0.148	V
		Vtdac6_W	Step 6 (Initial state+3)	0.068	0.076	0.084	V
	1-2 phase drive	Vtdac0_H	Step 0 (When initialized : channel 1 comparator level)	0.191	0.200	0.209	V
		Vtdac4_H	Step 4 (Initial state+1)	0.132	0.140	0.148	V
	2 phase drive	Vtdac4_F	Step 4' (When initialized : channel 1 comparator level)	0.191	0.200	0.209	V
	Current setting comparator threshold voltage (current attenuation rate switching)	Vtatt00	ATT1 = L, ATT2 = L	0.191	0.200	0.209	V
Vtatt01		ATT1 = H, ATT2 = L	0.152	0.160	0.168	V	
Vtatt10		ATT1 = L, ATT2 = H	0.112	0.120	0.128	V	
Vtatt11		ATT1 = H, ATT2 = H	0.072	0.080	0.088	V	
Chopping frequency	Fchop	Cchop = 220pF	36	45	54	kHz	
CHOP pin threshold voltage	VCHOPH		0.6	0.7	0.8	V	
	VCHOPL		0.17	0.2	0.23	V	
CHOP pin charge/discharge current	Ichop		7	10	13	μA	
MONI pin saturation voltage	Vsatmon	Imoni = 1mA		250	400	mV	

LV8712T

Package Dimensions

unit : mm (typ)

3260A

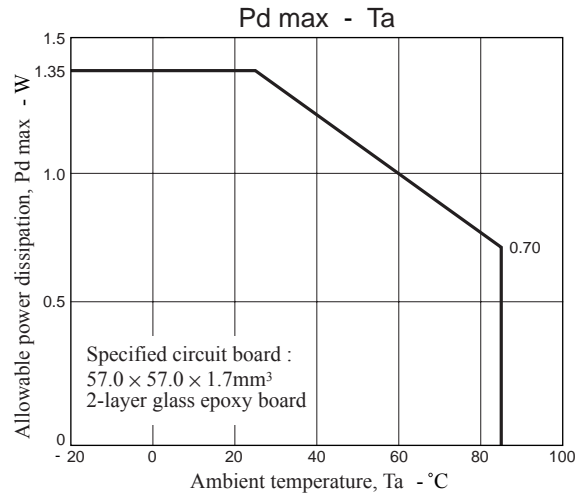
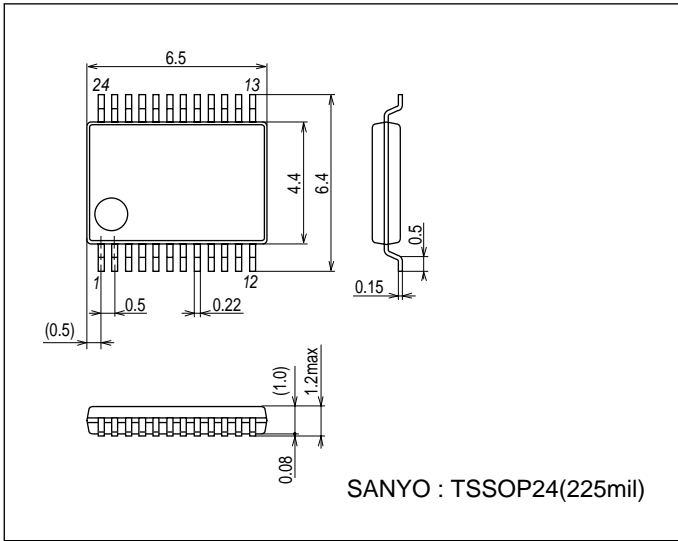

Pin Assignment

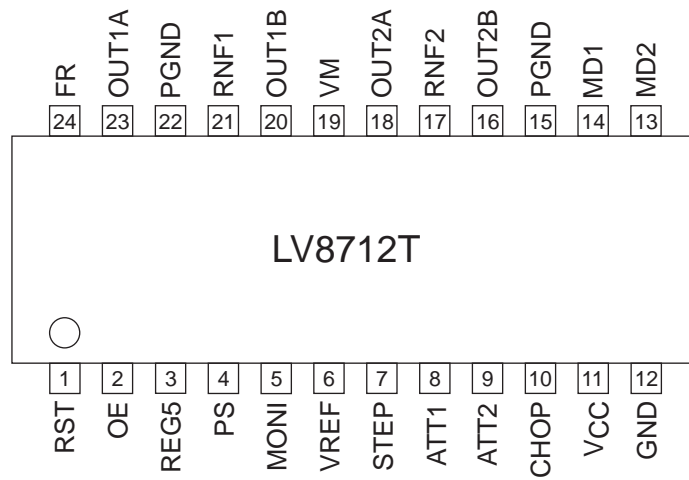

Block Diagram

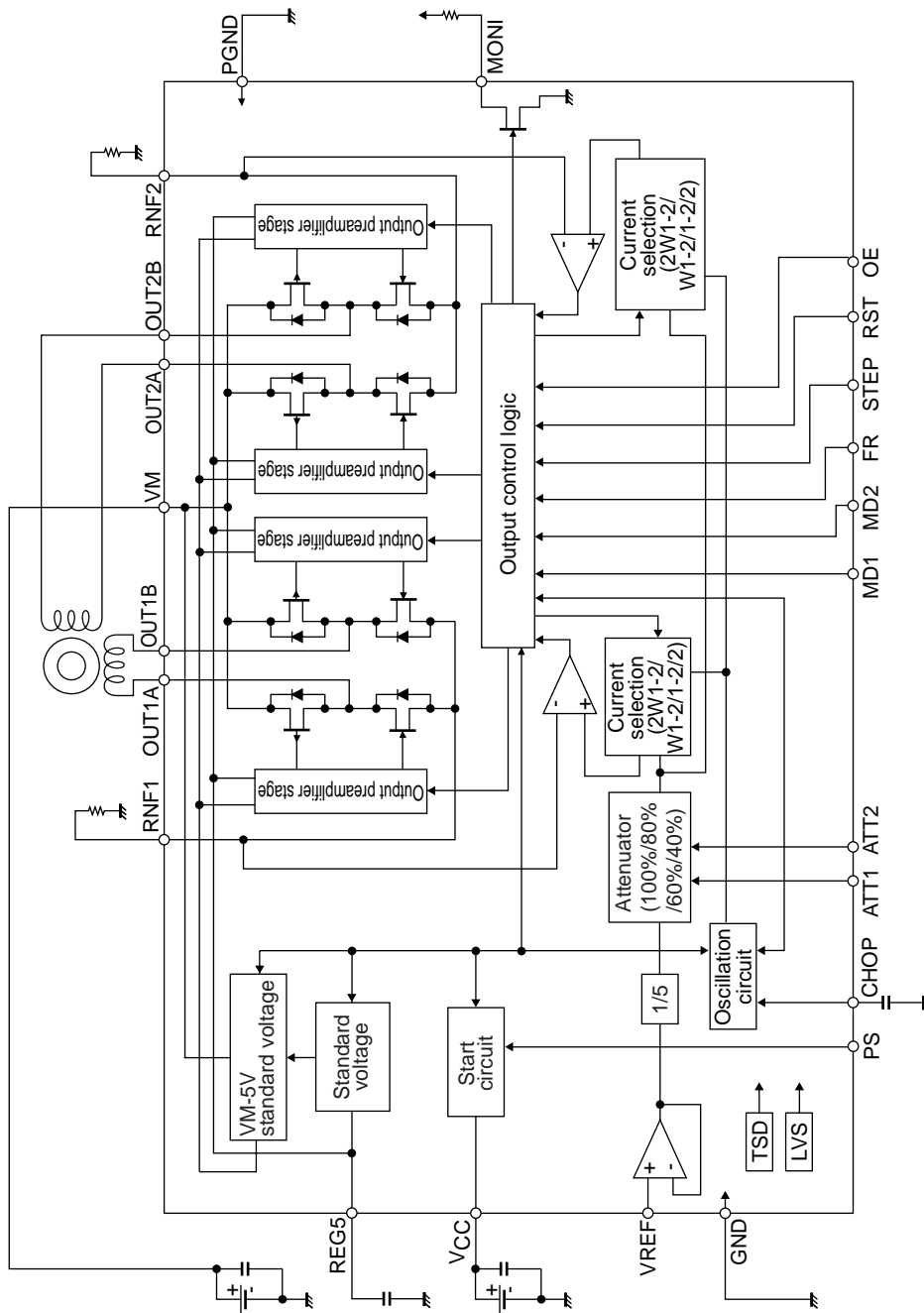

LV8712T

Pin Functions

Pin No.	Pin Name	Pin Function	Equivalent Circuit
1 2 7 8 9 13 14 24	RST OE STEP ATT1 ATT2 MD2 MD1 FR	Excitation reset signal input pin. Output enable signal input pin. STEP signal input pin. Motor holding current switching pin. Motor holding current switching pin. Excitation mode switching pin 2. Excitation mode switching pin 1. CW / CCW switching signal input pin.	
4	PS	Power save signal input pin.	
16 17 18 20 21 23	OUT2B RNF2 OUT2A OUT1B RNF1 OUT1A	Channel 2 OUTB output pin. Channel 2 current-sense resistor connection pin. Channel 2 OUTA output pin. Channel 1 OUTB output pin. Channel 1 current-sense resistor connection pin. Channel 1 OUTA output pin. Power	
6	VREF	Constant current control reference voltage input pin.	

Continued on next page.

LV8712T

Continued from preceding page.

Pin No.	Pin Name	Pin Function	Equivalent Circuit
3	REG5	Internal power supply capacitor connection pin.	
5	MONI	Position detection monitor pin.	
10	CHOP	Chopping frequency setting capacitor connection pin.	

Description of operation

Stepping motor control

(1) Power save function

This IC is switched between standby and operating mode by setting the PS pin. In standby mode, the IC is set to power-save mode and all logic is reset. In addition, the internal regulator circuit do not operate in standby mode.

PS	Mode	Internal regulator
Low or Open	Standby mode	Standby
High	Operating mode	Operating

(2) The order of turning on recommended power supply



The order of turning on each power supply recommends the following.

VCC power supply order → VM power supply order → PS pin = High

It becomes the above-mentioned opposite for power supply OFF.

However, the above-mentioned is a recommendation, the overcurrent is not caused by not having defended this, and IC is destroyed.

(3) STEP pin function

Input		Operating mode
PS	STP	
Low	*	Standby mode
High		Excitation step proceeds
High		Excitation step is kept

(4) Excitation mode setting function(initial position)

MD1	MD2	Excitation mode	Initial position	
			Channel 1	Channel 2
Low	Low	2 phase excitation	100%	-100%
High	Low	1-2 phase excitation	100%	0%
Low	High	W1-2 phase excitation	100%	0%
High	High	2W1-2 phase excitation	100%	0%

This is the initial position of each excitation mode in the initial state after power-on and when the counter is reset.

(5) Position detection monitoring function

The MONI position detection monitoring pin is of an open drian type.

When the excitation position is in the initial position, the MONI output is placed in the ON state.

(Refer to "(12) Examples of current waveforms in each of the excitation modes.")

(6) Reset function

RST	Operating mode
High	Normal operation
Low	Reset state

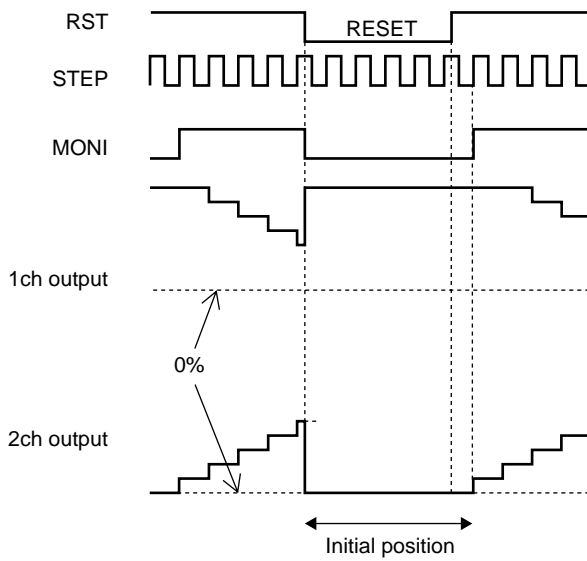

When the RST pin is set to Low, the excitation position of the output is forcibly set to the initial position, and the MONI output is placed in the ON state. When RST is then set to High, the excitation position is advanced by the next STEP input.

(7) Output enable function

OE	Operating mode
Low	Output ON
High	Output OFF

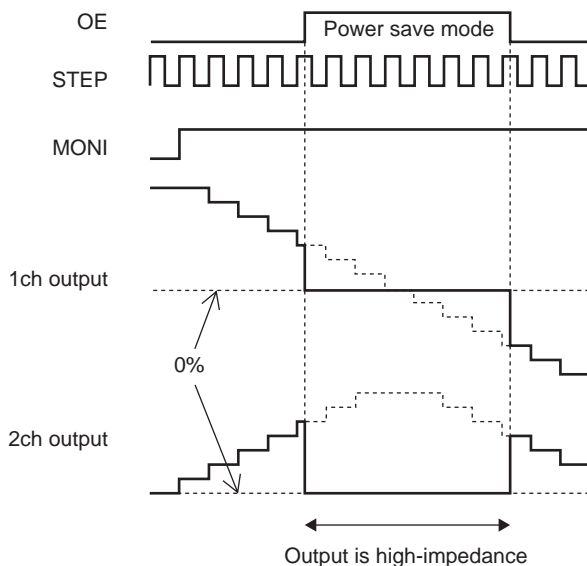

When the OE pin is set High, the output is forced OFF and goes to high impedance.

However, the internal logic circuits are operating, so the excitation position proceeds when the STEP signal is input.

Therefore, when OE is returned to Low, the output level conforms to the excitation position proceeded by the STEP input.

(8) Forward/reverse switching function

FR	Operating mode
Low	Clockwise (CW)
High	Counter-clockwise (CCW)

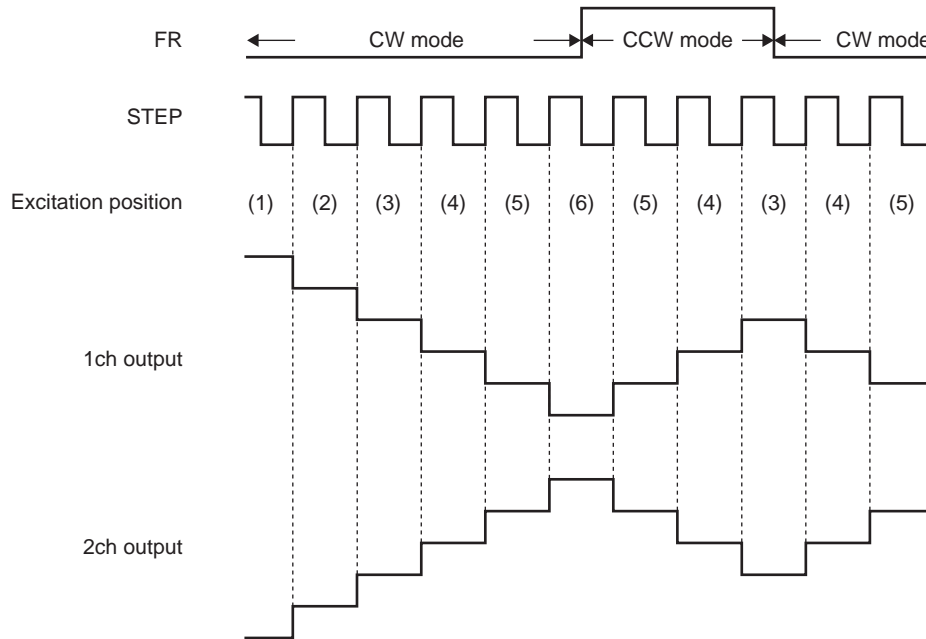

The internal D/A converter proceeds by one bit at the rising edge of the input STEP pulse. In addition, CW and CCW mode are switched by setting the FR pin. In CW mode, the channel 2 current phase is delayed by 90° relative to the channel 1 current. In CCW mode, the channel 2 current phase is advanced by 90° relative to the channel 1 current.

(9) Setting constant-current control

The setting of STM driver's constant current control is decided the VREF voltage from the resistance connected between RNF and GND by the following expression.

$$I_{OUT} = (VREF/5)/RNF \text{ resistance}$$

* The above setting is the output current at 100% of each excitation mode.

The voltage input to the VREF pin can be switched to four-step settings depending on the statuses of the two inputs, ATT1 and ATT2. This is effective for reducing power consumption when motor holding current is supplied.

Attenuation function for VREF input voltage

ATT1	ATT2	Current setting reference voltage attenuation ratio
Low	Low	100%
High	Low	80%
Low	High	60%
High	High	40%

The formula used to calculate the output current when using the function for attenuating the VREF input voltage is given below.

$$I_{OUT} = (VREF/5) \times (\text{attenuation ratio})/RNF \text{ resistance}$$

Example : At VREF of 1.0V, a reference voltage setting of 100% [(ATT1, ATT2) = (L, L)] and an RNF resistance of 0.5Ω, the output current is set as shown below.

$$I_{OUT} = 1.0V/5 \times 100\%/0.5\Omega = 400mA$$

If, in this state, (ATT1, ATT2) is set to (H, H), IO_{UT} will be as follows :

$$I_{OUT} = 400mA \times 40\% = 160mA$$

In this way, the output current is attenuated when the motor holding current is supplied so that power can be conserved.

LV8712T

(10) Chopping frequency setting

For constant-current control, this IC performs chopping operations at the frequency determined by the capacitor (Cchop) connected between the CHOP pin and GND.

The chopping frequency is set as shown below by the capacitor (Cchop) connected between the CHOP pin and GND.

$$T_{chop} \doteq C \times V \times 2 / I \text{ (s)}$$

V : Width of suresshu voltage, typ 0.5V

I : Charge/discharge current, typ 10μA

For instance, when Cchop is 200pF, the chopping frequency will be as follows :

$$F_{chop} \doteq 1 / T_{chop} \text{ (Hz)}$$

(11) Output current vector locus (one step is normalized to 90 degrees)

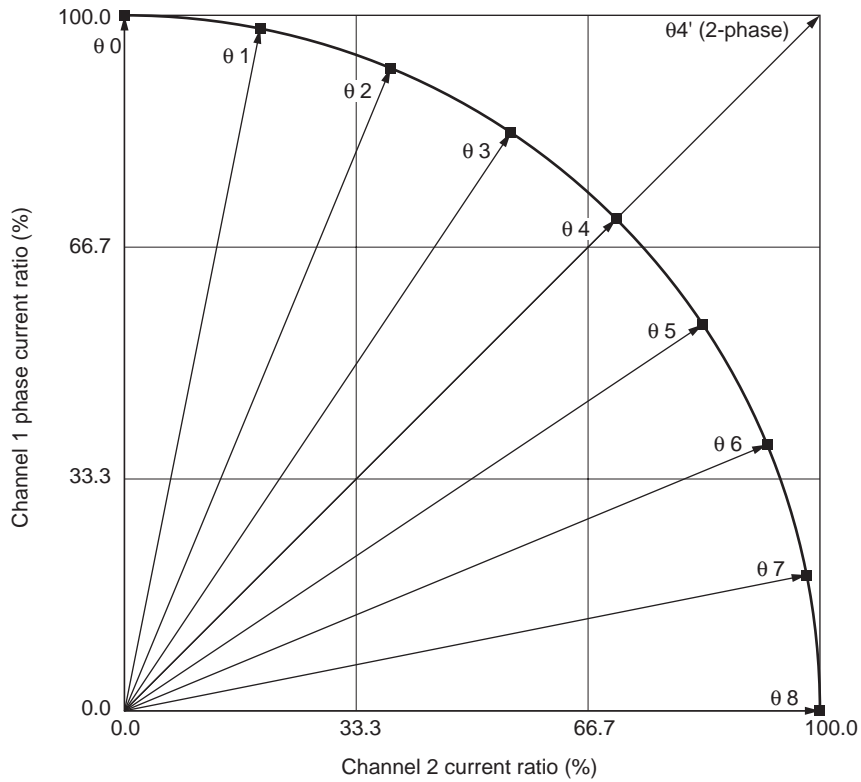

Setting current ration in each excitation mode

STEP	2W1-2 phase (%)		W1-2 phase (%)		1-2 phase (%)		2-phase (%)	
	Channel 1	Channel 2	Channel 1	Channel 2	Channel 1	Channel 2	Channel 1	Channel 2
00	100	0	100	0	100	0		
01	98	20						
02	92	38	92	38				
03	83	55						
04	70	70	70	70	70	70	100	100
05	55	83						
06	38	92	38	92				
07	20	98						
08	0	100	0	100	0	100		

LV8712T

(12) Typical current waveform in each excitation mode

2-phase excitation (CW mode)

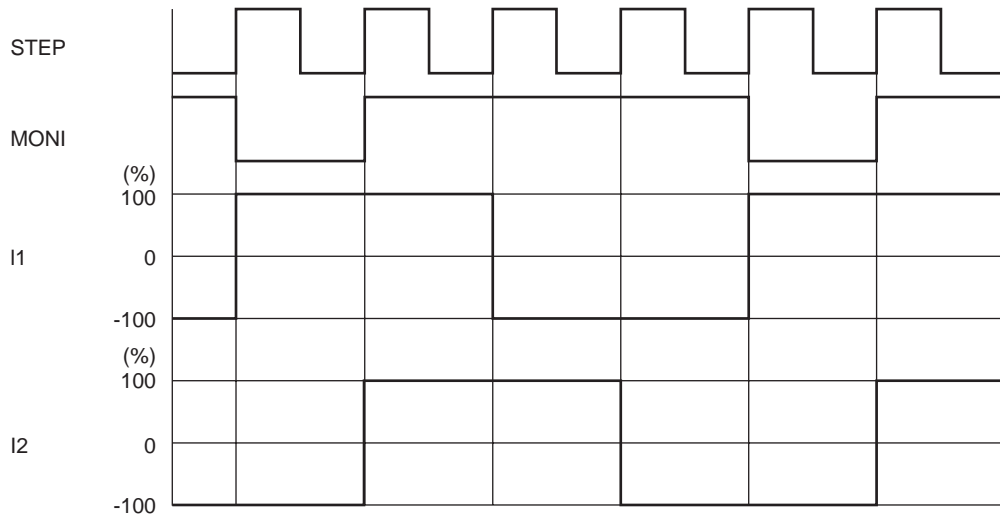

1-2 phase excitation (CW mode)

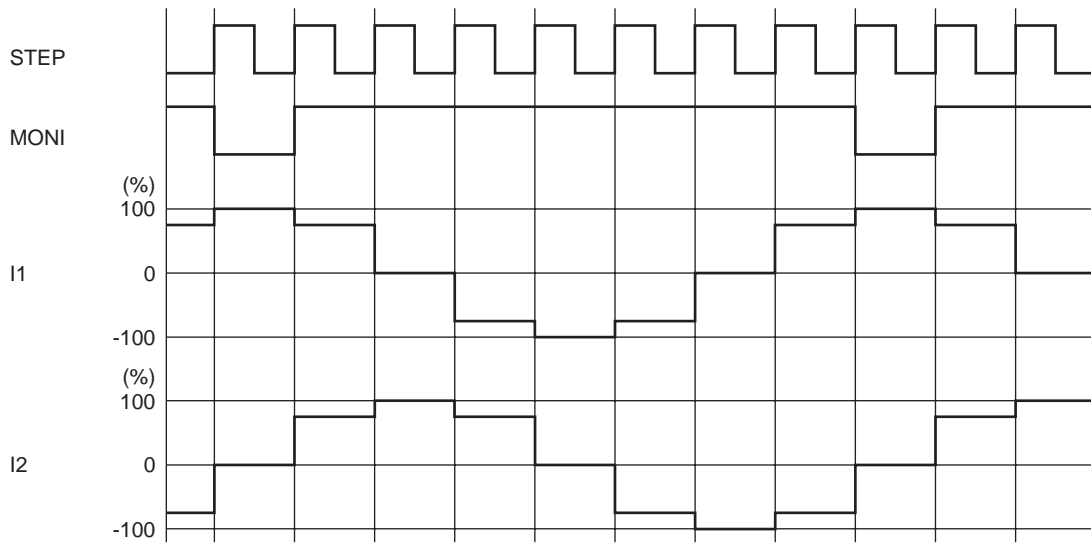

LV8712T

W1-2 phase excitation (CW mode)

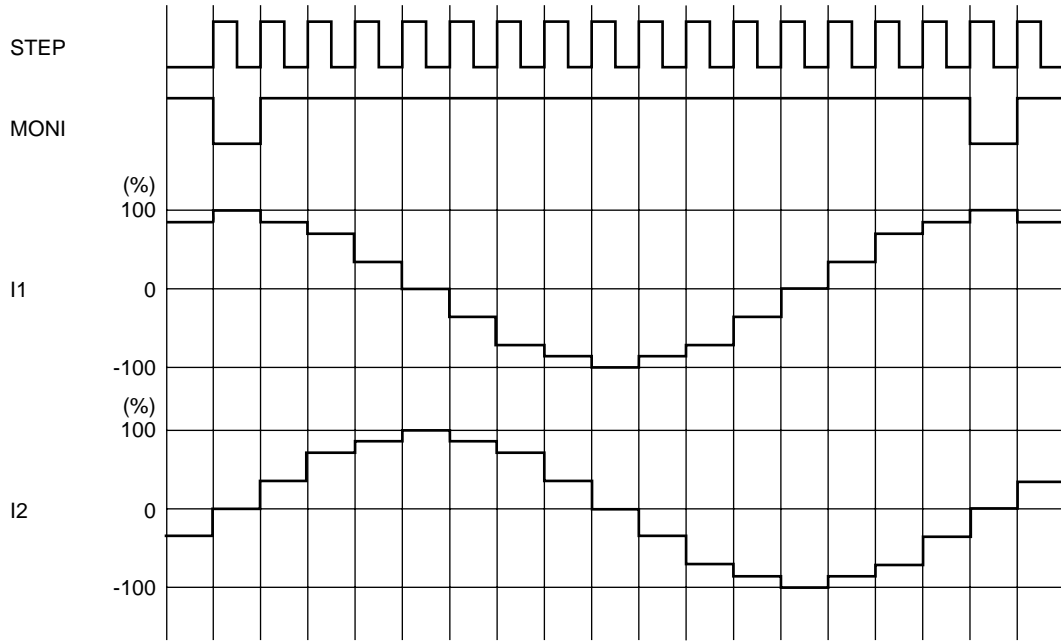

2W1-2 phase excitation (CW mode)

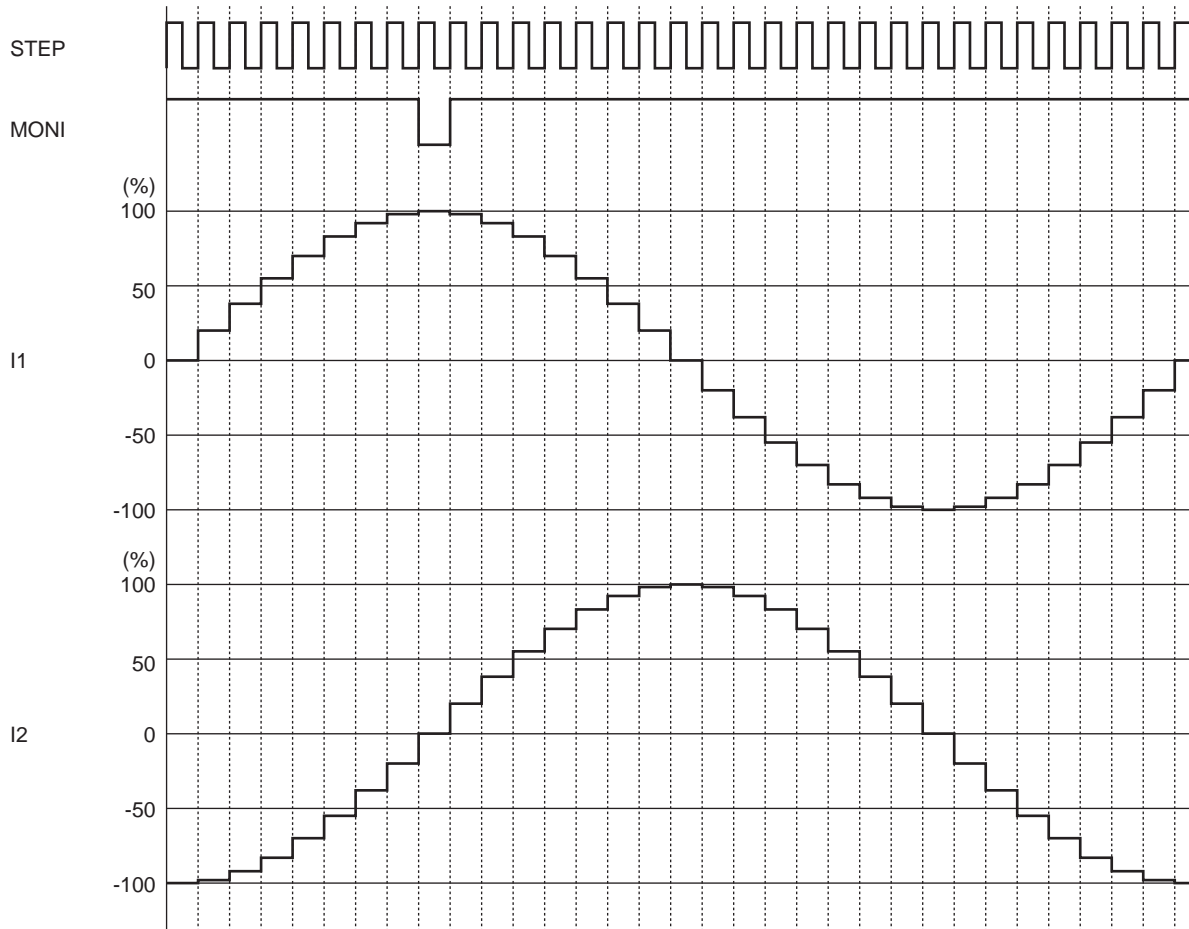

(13) Current control timing chart(Chopping operation)

(Sine wave increasing direction)

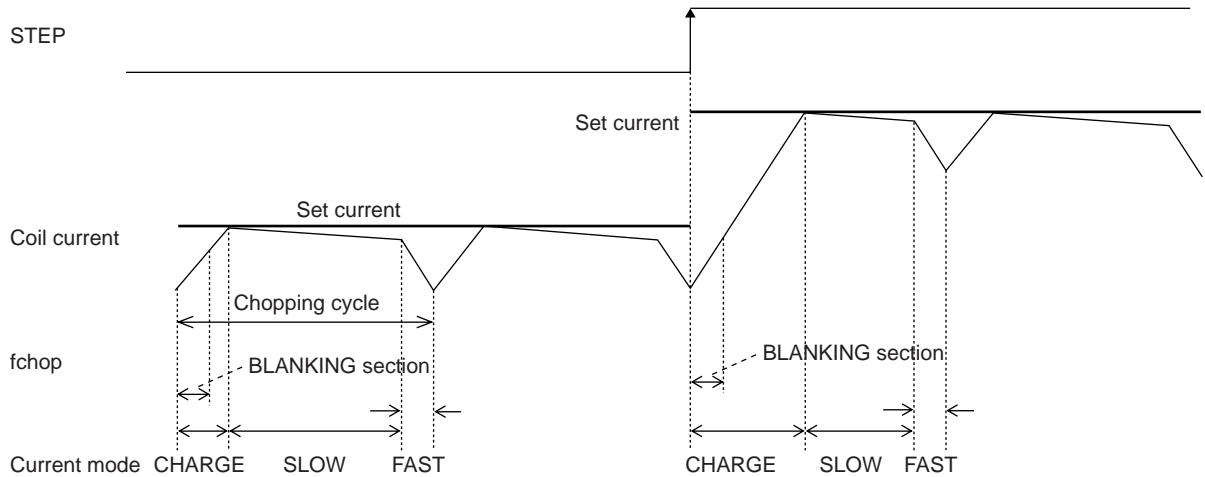

(Sine wave decreasing direction)

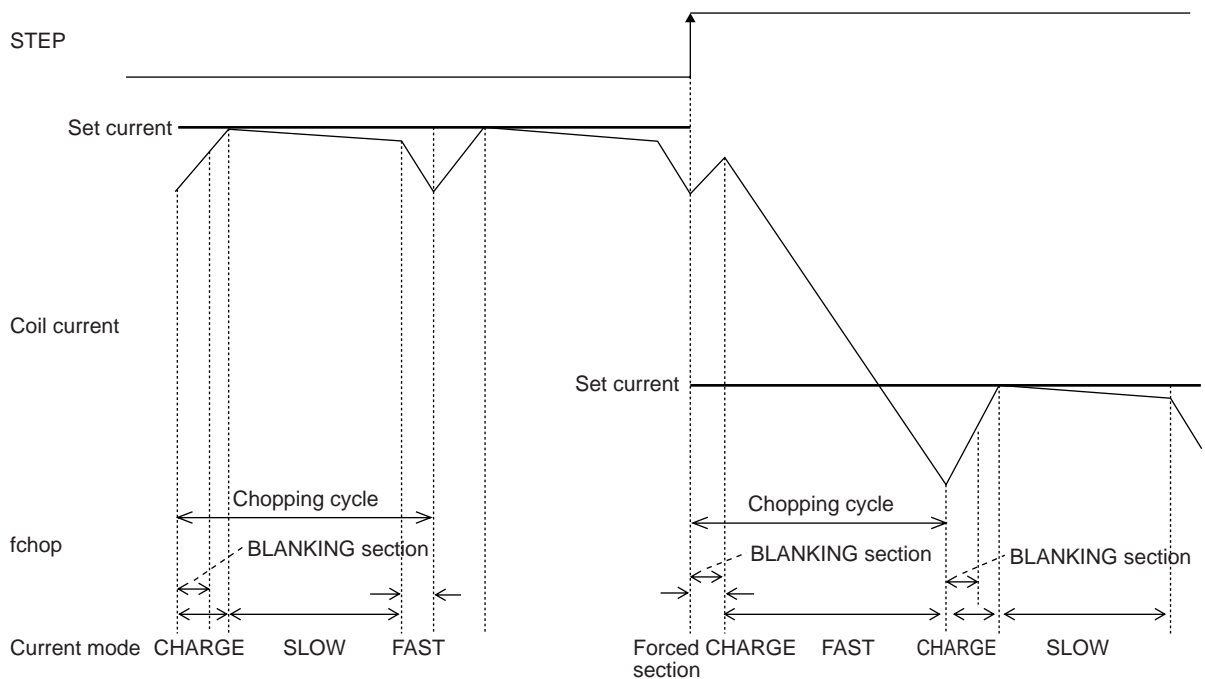

In each current mode, the operation sequence is as described below :

- At rise of chopping frequency, the CHARGE mode begins. (The Blanking section in which the CHARGE mode is forced regardless of the magnitude of the coil current (ICOIL) and set current (IREF) exists for 1 μ s.)
- The coil current (ICOIL) and set current (IREF) are compared in this blanking time.
 - When (ICOIL < IREF) state exists ;
 - The CHARGE mode up to ICOIL \geq IREF, then followed by changeover to the SLOW DECAY mode, and finally by the FAST DECAY mode for approximately 1 μ s.
 - When (ICOIL < IREF) state does not exist ;
 - The FAST DECAY mode begins. The coil current is attenuated in the FAST DECAY mode till one cycle of chopping is over.

Above operations are repeated. Normally, the SLOW (+FAST) DECAY mode continues in the sine wave increasing direction, then entering the FAST DECAY mode till the current is attenuated to the set level and followed by the SLOW DECAY mode.

LV8712T

Application Circuit Example

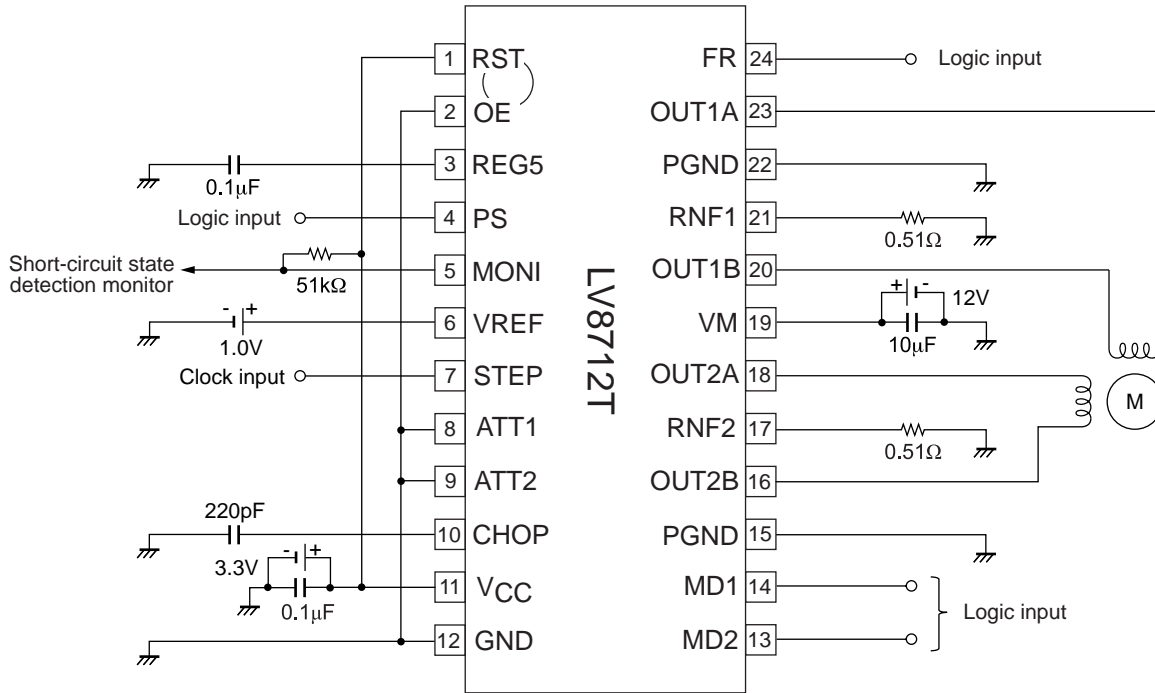

The formulae for setting the constants in the examples of the application circuits above are as follows :

Constant current (100%) setting

When $V_{REF} = 1.0V$

$$I_{OUT} = V_{REF}/5/RNF \text{ resistance}$$

$$= 1.0V/5/0.51\Omega = 0.392A$$

Chopping frequency setting

$$F_{chop} = I_{chop}/(C_{chop} \times V_{tchop} \times 2)$$

$$= 10\mu A/(220pF \times 0.5V \times 2) = 45kHz$$

- SANYO Semiconductor Co.,Ltd. assumes no responsibility for equipment failures that result from using products at values that exceed, even momentarily, rated values (such as maximum ratings, operating condition ranges, or other parameters) listed in products specifications of any and all SANYO Semiconductor Co.,Ltd. products described or contained herein.
- SANYO Semiconductor Co.,Ltd. strives to supply high-quality high-reliability products, however, any and all semiconductor products fail or malfunction with some probability. It is possible that these probabilistic failures or malfunction could give rise to accidents or events that could endanger human lives, trouble that could give rise to smoke or fire, or accidents that could cause damage to other property. When designing equipment, adopt safety measures so that these kinds of accidents or events cannot occur. Such measures include but are not limited to protective circuits and error prevention circuits for safe design, redundant design, and structural design.
- In the event that any or all SANYO Semiconductor Co.,Ltd. products described or contained herein are controlled under any of applicable local export control laws and regulations, such products may require the export license from the authorities concerned in accordance with the above law.
- No part of this publication may be reproduced or transmitted in any form or by any means, electronic or mechanical, including photocopying and recording, or any information storage or retrieval system, or otherwise, without the prior written consent of SANYO Semiconductor Co.,Ltd.
- Any and all information described or contained herein are subject to change without notice due to product/technology improvement, etc. When designing equipment, refer to the "Delivery Specification" for the SANYO Semiconductor Co.,Ltd. product that you intend to use.
- Information (including circuit diagrams and circuit parameters) herein is for example only; it is not guaranteed for volume production.
- Upon using the technical information or products described herein, neither warranty nor license shall be granted with regard to intellectual property rights or any other rights of SANYO Semiconductor Co.,Ltd. or any third party. SANYO Semiconductor Co.,Ltd. shall not be liable for any claim or suits with regard to a third party's intellectual property rights which has resulted from the use of the technical information and products mentioned above.

This catalog provides information as of February, 2011. Specifications and information herein are subject to change without notice.



Компания «ЭлектроПласт» предлагает заключение долгосрочных отношений при поставках импортных электронных компонентов на взаимовыгодных условиях!

Наши преимущества:

- Оперативные поставки широкого спектра электронных компонентов отечественного и импортного производства напрямую от производителей и с крупнейших мировых складов;
- Поставка более 17-ти миллионов наименований электронных компонентов;
- Поставка сложных, дефицитных, либо снятых с производства позиций;
- Оперативные сроки поставки под заказ (от 5 рабочих дней);
- Экспресс доставка в любую точку России;
- Техническая поддержка проекта, помощь в подборе аналогов, поставка прототипов;
- Система менеджмента качества сертифицирована по Международному стандарту ISO 9001;
- Лицензия ФСБ на осуществление работ с использованием сведений, составляющих государственную тайну;
- Поставка специализированных компонентов (Xilinx, Altera, Analog Devices, Intersil, Interpoint, Microsemi, Aeroflex, Peregrine, Syfer, Eurofarad, Texas Instrument, Miteq, Cobham, E2V, MA-COM, Hittite, Mini-Circuits, General Dynamics и др.);

Помимо этого, одним из направлений компании «ЭлектроПласт» является направление «Источники питания». Мы предлагаем Вам помощь Конструкторского отдела:

- Подбор оптимального решения, техническое обоснование при выборе компонента;
- Подбор аналогов;
- Консультации по применению компонента;
- Поставка образцов и прототипов;
- Техническая поддержка проекта;
- Защита от снятия компонента с производства.



Как с нами связаться

Телефон: 8 (812) 309 58 32 (многоканальный)

Факс: 8 (812) 320-02-42

Электронная почта: org@eplast1.ru

Адрес: 198099, г. Санкт-Петербург, ул. Калинина, дом 2, корпус 4, литера А.