

Quick Start Guide

TRK-KEA

Kinetis EA Series MCUs for
Automotive Electronics Applications



StarterTRAK

Get to know the TRK-KEA

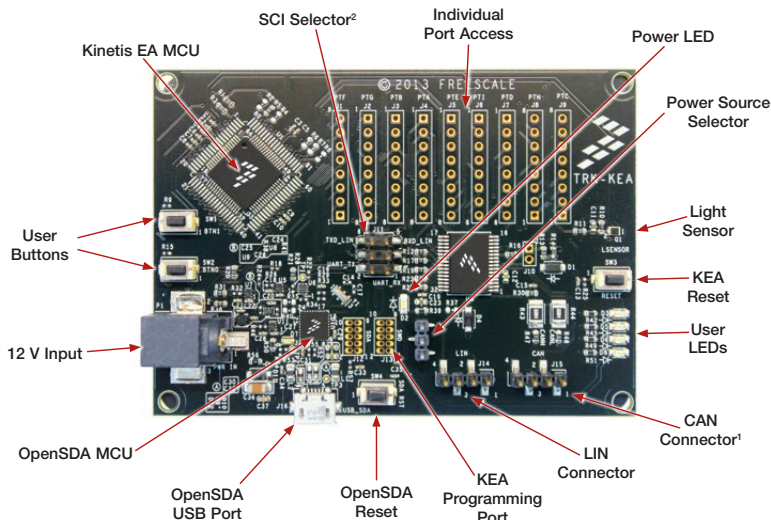

Figure 1: Front side of TRK-KEA

¹ Only available on TRK-KEA128

² Only available on TRK-KEA8

Introduction and Default Settings

The TRK-KEA features either one of the KEA128, KEA64 or KEA8 MCUs, depending on the board version. The KEA family is aimed at automotive body electronic applications.

Kinetis EA series MCUs integrate an ARM® Cortex®-M0+ core, a CAN module³, a UART module with LIN capabilities, a pulse width timer (PWT) and a keyboard interrupt module (KBI). All these peripherals together with standard serial communication protocols such as I²C and SPI offer flexibility for a width variety of applications.

The TRK-KEA board includes an onboard OpenSDA programmer and debugger, LIN physical transceiver, CAN physical transceiver, a light sensor, four LEDs and two pushbuttons for user interface.

This guide will show how to connect the board to a host PC and execute a demonstration application preloaded into the flash memory, with the goal to prototype in 24 Hours. Default jumper positions of the TRK-KEA board are shown in the figure.

³ Only available on KEA128



Software Tools Installation

1 Install CodeWarrior Development Studio

Freescale's Codewarrior for MCUs integrates several functionalities into a rapid development software bundle. It features support for ARM architecture code development and compilation in a friendly user interface. It also features a powerful debugging tool that can support various debugging tools including the low cost OpenSDA interface. Along with this, Codewarrior includes the Processor Expert tool. This tool allows to create, configure, optimize, migrate, and deliver software components that generate source code for Freescale silicon quickly and easily.

The latest version of CodeWarrior for MCUs (Eclipse IDE) can be downloaded from **freescale.com/CodeWarrior**.

2 Launch the Demo Program

The DVD contains CodeWarrior projects to exercise the different modules of the Kinetis EA series MCU, including the UART, FTM, ADC and keyboard interrupts (KBI) modules.

Jumper Default Configuration

Jumper	Setting	Description
J10*	1-3, 2-4	UART to OpenSDA serial selection
J13	1-2	Power selection, USB enabled

*J10 only available on TRK-KEA8

Jumper List and Description

Jumper	Description
	SCI Selector
J10	Pin 1-3 closed: UART to OpenSDA Rx
	Pin 5-3 closed: UART to LIN Rx
	Pin 2-4 closed: UART to OpenSDA Tx
	Pin 6-4 closed: UART to LIN Tx
	Power Source Selector
J13	Pins 1-2 closed: USB source
	Pin 3-2 closed: External source



Headers and Connectors List

Header/ Connector	Description
J1	User access port F
J2	User access port G
J3	User access port B
J4	User access port A
J5	User access port E
J6	User access port I
J7	User access port D
J8	User access port H
J9	User access port C
J11	SDA port (external program and debug interface)—OpenSDA MCU
J12	SWD port (external program and debug interface)—Main MCU
J14	LIN connector
J15*	CAN connector

*J15 only available on TRK-KEA128

Peripheral List

Peripheral	ID	MCU Port	Description
Light sensor	Q1	ADC0_SE3	Light sensor connected to ADC channel 3
LED	D3	C0	Blue led connected to port C0
	D5	C1	Blue led connected to port C1
	D6	C2	Blue led connected to port C2
	D8	C3	Blue led connected to port C3
Button	SW1*	D0/C4	Switch connected to port D0/C4
	SW2**	D1/C5	Switch connected to port D1/C5

* SW1 connected to port D0 for TRK-KEA128 and TRK-KEA64. SW1 connected to port C4 for TRK-KEA8

** SW2 connected to port D1 for TRK-KEA128 and TRK-KEA64. SW2 connected to port C5 for TRK-KEA8



Support

Visit freescale.com/support for a list of phone numbers within your region.

Warranty

Visit freescale.com/warranty for complete warranty information.

For more information, visit
freescale.com/TRK-KEA128
freescale.com/TRK-KEA64
freescale.com/TRK-KEA8

Freescale, the Freescale logo, CodeWarrior and Kinetis are trademarks of Freescale Semiconductor, Inc., Reg. U.S. Pat. & Tm. Off. All other product or service names are the property of their respective owners. ARM and Cortex are registered trademarks of ARM Limited (or its subsidiaries) in the EU and/or elsewhere. All rights reserved.

© 2014 Freescale Semiconductor, Inc.

Doc Number: KINTESMCUAUTQSG REV 0
Agile Number: 926-78850 REV 0





Компания «ЭлектроПласт» предлагает заключение долгосрочных отношений при поставках импортных электронных компонентов на взаимовыгодных условиях!

Наши преимущества:

- Оперативные поставки широкого спектра электронных компонентов отечественного и импортного производства напрямую от производителей и с крупнейших мировых складов;
- Поставка более 17-ти миллионов наименований электронных компонентов;
- Поставка сложных, дефицитных, либо снятых с производства позиций;
- Оперативные сроки поставки под заказ (от 5 рабочих дней);
- Экспресс доставка в любую точку России;
- Техническая поддержка проекта, помощь в подборе аналогов, поставка прототипов;
- Система менеджмента качества сертифицирована по Международному стандарту ISO 9001;
- Лицензия ФСБ на осуществление работ с использованием сведений, составляющих государственную тайну;
- Поставка специализированных компонентов (Xilinx, Altera, Analog Devices, Intersil, Interpoint, Microsemi, Aeroflex, Peregrine, Syfer, Eurofarad, Texas Instrument, Miteq, Cobham, E2V, MA-COM, Hittite, Mini-Circuits, General Dynamics и др.);

Помимо этого, одним из направлений компании «ЭлектроПласт» является направление «Источники питания». Мы предлагаем Вам помощь Конструкторского отдела:

- Подбор оптимального решения, техническое обоснование при выборе компонента;
- Подбор аналогов;
- Консультации по применению компонента;
- Поставка образцов и прототипов;
- Техническая поддержка проекта;
- Защита от снятия компонента с производства.



Как с нами связаться

Телефон: 8 (812) 309 58 32 (многоканальный)

Факс: 8 (812) 320-02-42

Электронная почта: org@eplast1.ru

Адрес: 198099, г. Санкт-Петербург, ул. Калинина, дом 2, корпус 4, литера А.