



USBF TV (USB-A)

USB Connection System for Harsh Environment



With USB Field, you can insert a standard USB 2.0 cordset into a metallic plug which will protect it from shocks, dust and fluids.

No hazardous on-field cabling and grounding!

This metallic plug is connected into a receptacle, using a Tri Start Thread coupling mechanism (MIL-DTL-38999 series III type) with anti-decoupling device for high vibrations.

Applications

- Embedded Computers
- Data Acquisition and transmission in harsh environment
- Railways
- Battelfield Communication Systems
- Navy Systems

Data Transmission

USB Specification 2.0
Data Rate: Up to 480 Mb/s for High Speed USB

MAIN CHARACTERISTICS

- Sealed against fluids and dusts (IP68)
- Shock, Vibration and Traction resistant
- No cabling operation in field and no tools required
- Improved EMI protection
- Tri Start Thread coupling mechanism (MIL-DTL-38999 series III type) with anti-decoupling device
- 2 mechanical Coding / Polarization possibilities by the user (receptacle insert rotation)
- USBF TV plug retention in the receptacle: 100 N in the axis
- Mating cycles: 500 to 1500

Environmental Protection

- Sealing (when mated): IP68 (Temporary immersion)
- Salt Spray: 48 h with Nickel plating
> 500 h with Olive Drab Cadmium
1000 h with marine bronze shell
- Fire Retardant / Low Smoke: UL94 V0 and NF F 16 101 & 16 102
- Vibrations: 10 – 500 Hz, 10 g, 3 axes: no discontinuity > 1micro s
- Shocks: IK06: weight of 250 g drop from 40 cm [15.75 in] onto connectors (mated pair)
- Humidity: 21 days, 43°C, 98% humidity
- Temperature Range: - 40°C / +85°C

Part Number Code

Series	USBF TV	2	1	G
USB Field TV				
Shell Type				
6:	Plug			
2:	Square flange receptacle			
2PE:	Square flange receptacle with metal backshell (type 1) & with metal backshell + plastic gland (type 2)			
2PEM:	Square flange receptacle with backshell + metal gland (only for back termination type 2 = Solder)			
7:	Jam nut receptacle			
7PE:	Jam nut receptacle with metal backshell (type 1) & with metal backshell + plastic gland (type 2)			
7PEM:	Jam nut receptacle with backshell + metal gland (only for back termination type 2 = Solder)			
Back Terminations (Receptacles only)				
1:	Female USB-A			
2:	Solder (4 tinned holes)			
Shells Material & Finish				
N:	Aluminium shell - Nickel plating - ROHS compliant			
G:	Aluminium shell - Olive Drab Cadmium plating			
BZ:	Marine bronze shell - ROHS compliant			

- Examples:
- Olive Drab Cadmium Plug: USBF TV 6G
 - Olive Drab Cadmium Square Flange Receptacle, USB-A back terminat°: USBF TV 21G
 - Olive Drab Cadmium Jam Nut Receptacle, USB-A receptacle back terminat°: USBF TV 71G
 - Nickel Jam Nut Receptacle, solder termination: USBF TV 72N

Plug

- Shell type 6

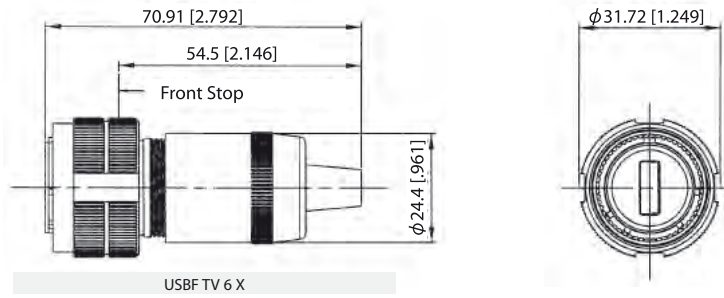

Receptacles

- Square flange receptacle
4 mounting holes: Shell type 2

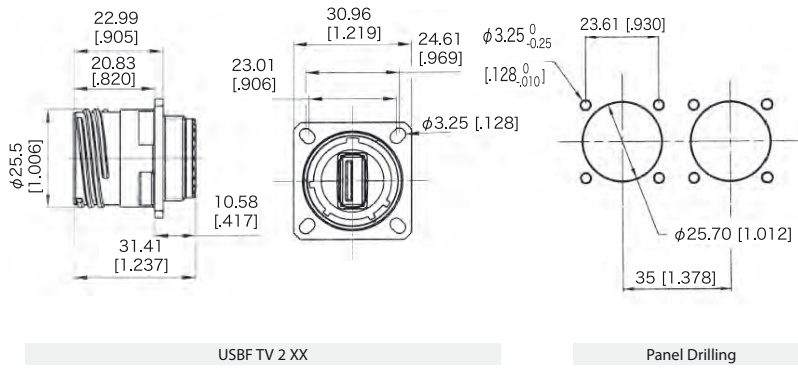

- Jam nut receptacle
Hexagonal Nut mounting:
Shell type 7

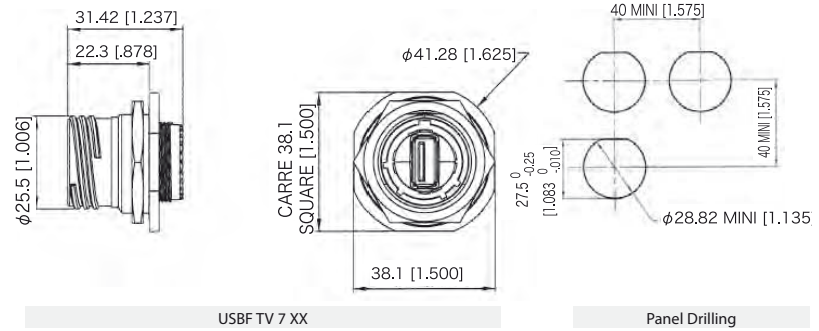

- Receptacles with backshell
Shell type 2PE and 7PE

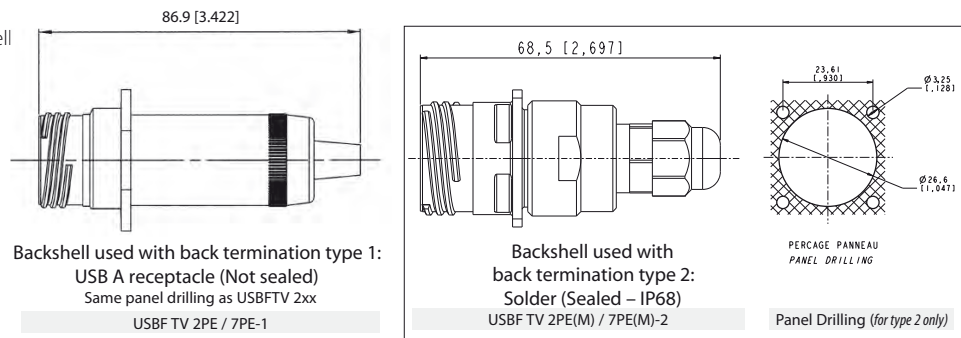

Back Terminations



Type 1: Female USB-A



Type 2: Solder 4 Tinned holes to solder your cable

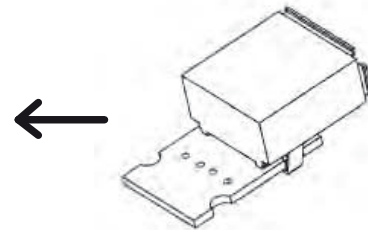

View of the PCB of the Type 2 version with 4 tinned holes for solder termination

Assembly Instructions

Can be used with most the USB cordset brands: No tools required!

Plug Assembly

1. Only if you need a full sealing (IP68): Install the white sticker around the plug, covering the 4 little holes of the overmolding
2. Insert the black O Ring around the front face of the USB A plug. This O Ring will ensure connection sealing
3. Insert the USB cordset into the metallic backshell
4. Insert the retention spacer laterally to the cable (this spacer is soft, in order to adapt to different shapes of overmolding) and slide the overmolding of the USB-A plug into this retention spacer
5. Insert the friction ring laterally to the cable
6. Choose the right coding (2 positions) and insert the USB-A plug into the protective plug. Note at this step, the main key is used for polarization.



7. Screw the backshell on the plug body. A wrench can be necessary to fully tighten it, and the connection to the receptacle can help

IMPORTANT NOTE

The connection sealing is not done by the black retention spacer (which is slotted), but by the front face ORing (fig. 2)

Receptacle Assembly

Insert the USB module from the rear. Reference is main key. Beware to have a coding compatible with the coding you used for the plug: on front view, the white shapes in the USBs must be on the same side.

To remove the USB module, insert the removal tool **USBF ODE** from the front, and push back the module.

Accessories

■ Metallic Caps

	USBF TVC	2	G
Connector Type			
6:	Plug		
2:	Square Flange Receptacle		
7:	Jam Nut Receptacle		
Shells Material & Finish			
N:	Aluminium shell - Nickel - ROHS compliant		
G:	Aluminium shell - Olive Drab Cadmium		
BZ:	Marine bronze shell - ROHS compliant		

■ Panel Gasket for square flange receptacle

(Thickness: 0,8 mm [.031]): JE15



■ Receptacle Insert removal tool: USBF ODE

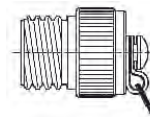

Plug Cap



Receptacle Cap

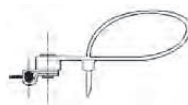

Plug Cap end

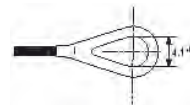

Square flange receptacle cap end

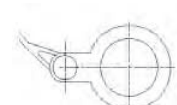

Jam Nut receptacle cap end



Компания «ЭлектроПласт» предлагает заключение долгосрочных отношений при поставках импортных электронных компонентов на взаимовыгодных условиях!

Наши преимущества:

- Оперативные поставки широкого спектра электронных компонентов отечественного и импортного производства напрямую от производителей и с крупнейших мировых складов;
- Поставка более 17-ти миллионов наименований электронных компонентов;
- Поставка сложных, дефицитных, либо снятых с производства позиций;
- Оперативные сроки поставки под заказ (от 5 рабочих дней);
- Экспресс доставка в любую точку России;
- Техническая поддержка проекта, помощь в подборе аналогов, поставка прототипов;
- Система менеджмента качества сертифицирована по Международному стандарту ISO 9001;
- Лицензия ФСБ на осуществление работ с использованием сведений, составляющих государственную тайну;
- Поставка специализированных компонентов (Xilinx, Altera, Analog Devices, Intersil, Interpoint, Microsemi, Aeroflex, Peregrine, Syfer, Eurofarad, Texas Instrument, Miteq, Cobham, E2V, MA-COM, Hittite, Mini-Circuits, General Dynamics и др.);

Помимо этого, одним из направлений компании «ЭлектроПласт» является направление «Источники питания». Мы предлагаем Вам помощь Конструкторского отдела:

- Подбор оптимального решения, техническое обоснование при выборе компонента;
- Подбор аналогов;
- Консультации по применению компонента;
- Поставка образцов и прототипов;
- Техническая поддержка проекта;
- Защита от снятия компонента с производства.



Как с нами связаться

Телефон: 8 (812) 309 58 32 (многоканальный)

Факс: 8 (812) 320-02-42

Электронная почта: org@eplast1.ru

Адрес: 198099, г. Санкт-Петербург, ул. Калинина, дом 2, корпус 4, литера А.