



FEATURES

- RoHS compliant
- UL 60950 recognized
- Power density 0.42W/cm³
- Wide temperature performance at full 1 watt load, -40°C to 60°C
- Single and dual outputs
- UL 94V-0 package material
- No heatsink required
- Footprint 1.91cm²
- SIP package style
- 5.2kVDC isolation
- 3V, 5V & 12V input
- 3V, 5V, 9V, 12V and 15V output
- Internal SMD construction
- Fully encapsulated with toroidal magnetics
- Pin compatible with the NMV series SIP DC/DC converters
- MTTF up to 13 million hours
- Custom solutions available

PRODUCT OVERVIEW

The NMJ series are dual and single output DC/DC converters in a 7 pin SIP package style offering pin and functionality compatibility with the NMV series SIP DC/DC converters. The NMJ series is UL60950 recognized and suitable for applications where safety and miniaturisation are of paramount importance. Isolation barrier approved for supplementary/reinforced insulation - see page 2.

SELECTION GUIDE

| Order Code | Nominal Input Voltage | Output Voltage | Output Current | Ripple & Noise ³ | Efficiency (Min.) | Isolation Capacitance | MTTF ¹ |
|------------|-----------------------|----------------|----------------|-----------------------------|-------------------|-----------------------|-------------------|
| | V | V | mA | mV p-p | % | pF | kHrs |
| NMJ0505SC | 5 | ±5 | ±100 | 40 | 60 | 3.0 | 4950 |
| NMJ0509SC | 5 | ±9 | ±55 | 30 | 65 | 3.0 | 3832 |
| NMJ0512SC | 5 | ±12 | ±42 | 20 | 65 | 3.0 | 2770 |
| NMJ0515SC | 5 | ±15 | ±33 | 20 | 65 | 3.0 | 1903 |
| NMJ1205SC | 12 | ±5 | ±100 | 40 | 60 | 3.0 | 3688 |
| NMJ1209SC | 12 | ±9 | ±55 | 30 | 65 | 3.0 | 3029 |
| NMJ1212SC | 12 | ±12 | ±42 | 20 | 65 | 3.0 | 2324 |
| NMJ1215SC | 12 | ±15 | ±33 | 20 | 65 | 3.0 | 1682 |
| NMJ0303SAC | 3.3 | 3.3 | 303 | 70 | 66 | 3.0 | 13780 |
| NMJ0503SAC | 5 | 3.3 | 303 | 60 | 64 | 3.0 | 13460 |
| NMJ0505SAC | 5 | 5 | 200 | 50 | 68 | 3.0 | 13360 |
| NMJ0509SAC | 5 | 9 | 111 | 50 | 72 | 3.0 | 12700 |
| NMJ0512SAC | 5 | 12 | 83 | 50 | 71 | 3.0 | 11490 |
| NMJ0515SAC | 5 | 15 | 66 | 50 | 71 | 3.0 | 9980 |
| NMJ1205SAC | 12 | 5 | 200 | 50 | 69 | 3.0 | 8447 |
| NMJ1209SAC | 12 | 9 | 111 | 50 | 73 | 3.0 | 8176 |
| NMJ1212SAC | 12 | 12 | 83 | 50 | 73 | 3.0 | 7660 |
| NMJ1215SAC | 12 | 15 | 66 | 50 | 74 | 3.0 | 6950 |

INPUT CHARACTERISTICS

| Parameter | Conditions | Min. | Typ. | Max. | Units |
|---------------|---------------------------------------|------|------|------|-------|
| Voltage range | Continuous operation, 3V input types | 2.97 | 3.3 | 3.63 | V |
| | Continuous operation, 5V input types | 4.5 | 5 | 5.5 | |
| | Continuous operation, 12V input types | 10.8 | 12 | 13.2 | |

OUTPUT CHARACTERISTICS

| Parameter | Conditions | Min. | Typ. | Max. | Units |
|-----------------------------|---|------|------|------|-------|
| Rated Power ² | T _A = -40°C to 60°C | | | 1 | W |
| Voltage Set Point Accuracy | See tolerance envelopes | | | | |
| Line regulation | High V _{IN} to low V _{IN} | | 1.0 | 1.2 | %/% |
| Load regulation | 10% load to rated load, xx03 | | 10.0 | 15.0 | % |
| | 10% load to rated load, 0505 | | 7.0 | 10.0 | |
| | 10% load to rated load, 0509, 0512, 0515 | | 6.0 | 10.0 | |
| | 10% load to rated load, 12xx | | 5.0 | 7.0 | |
| Load regulation | 10% load to rated load, 5V output types | | 10.0 | 15.0 | % |
| | 10% load to rated load, 9V output types | | 6.0 | 10.0 | |
| | 10% load to rated load, 12V output types | | 6.0 | 10.0 | |
| | 10% load to rated load, 15V output types | | 6.0 | 10.0 | |
| Zero Load Power Consumption | All types | | 250 | | mW |

ABSOLUTE MAXIMUM RATINGS

| | |
|---|-------|
| Lead temperature 1.5mm from case for 10 seconds | 300°C |
| Input voltage V _{IN} , NMJ03 types | 5V |
| Input voltage V _{IN} , NMJ05 types | 7V |
| Input voltage V _{IN} , NMJ12 types | 15V |

1. Calculated using MIL-HDBK-217 FN2 calculation model with nominal input voltage at full load.
 2. See derating graph.
 3. See ripple & noise test method.
- All specifications typical at T_A = 25°C, nominal input voltage and rated output current unless otherwise specified.



ISOLATION CHARACTERISTICS

| Parameter | Conditions | Min. | Typ. | Max. | Units |
|------------------------|---------------------------|------|------|------|-------|
| Isolation test voltage | Flash tested for 1 second | 5200 | | | VDC |
| Resistance | Viso= 500VDC | | 1 | | GΩ |

GENERAL CHARACTERISTICS

| Parameter | Conditions | Min. | Typ. | Max. | Units |
|---------------------|---------------|------|------|------|-------|
| Switching frequency | Single output | | 45 | | kHz |
| | Dual output | | 70 | | |

TEMPERATURE CHARACTERISTICS

| Parameter | Conditions | Min. | Typ. | Max. | Units |
|--------------------------------|---------------------|------|------|------|-------|
| Specification | All output types | -40 | | 60 | °C |
| Storage | | -55 | | 130 | |
| Case Temperature above ambient | All output types | | | 33 | |
| Cooling | Free air convection | | | | |

TEMPERATURE DERATING GRAPH

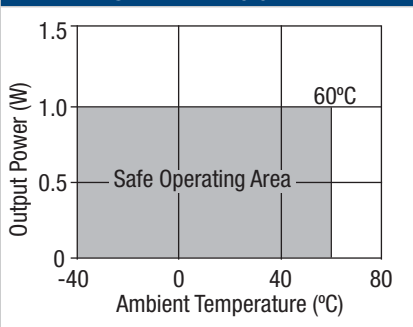

TOLERANCE ENVELOPE

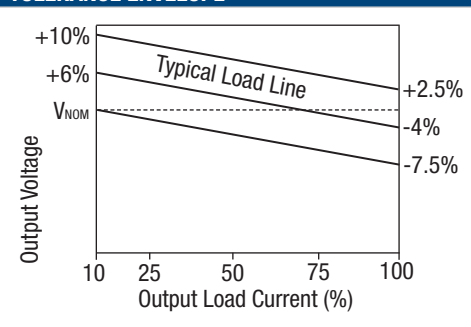

TOLERANCE ENVELOPE, 3.3V in, 3V out type only

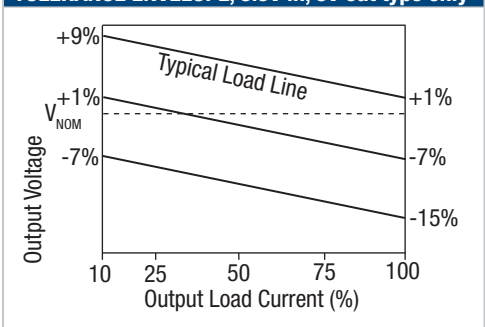

TECHNICAL NOTES

ISOLATION VOLTAGE

'Hi Pot Test', 'Flash Tested', 'Withstand Voltage', 'Proof Voltage', 'Dielectric Withstand Voltage' & 'Isolation Test Voltage' are all terms that relate to the same thing, a test voltage, applied for a specified time, across a component designed to provide electrical isolation, to verify the integrity of that isolation.

Murata Power Solutions NMJ series of DC/DC converters are all 100% production tested at their stated isolation voltage. This is 5.2kVDC for 1 second.

A question commonly asked is, "What is the continuous voltage that can be applied across the part in normal operation?"

The NMJ series has been recognized by Underwriters Laboratory to 300Vrms for Supplementary Insulation and 150Vrms for Reinforced Insulation.

REPEATED HIGH-VOLTAGE ISOLATION TESTING

It is well known that repeated high-voltage isolation testing of a barrier component can actually degrade isolation capability, to a lesser or greater degree depending on materials, construction and environment. We therefore strongly advise against repeated high voltage isolation testing, but if it is absolutely required, that the voltage be reduced by 20% from specified test voltage.

SAFETY APPROVAL

The NMJ series has been recognised by Underwriters Laboratory (UL) to UL 60950 for supplementary insulation up to 300Vrms and reinforced insulation up to 150Vrms at a maximum ambient temperature of 60°C. File number E179522 applies.

RoHS COMPLIANCE INFORMATION



This series is compatible with RoHS soldering systems with a peak wave solder temperature of 300°C for 10 seconds. The pin termination finish on this product series is Tin Plate, Hot Dipped over Matte Tin with Nickel Preplate. The series is backward compatible with Sn/Pb soldering systems.

For further information, please visit www.murata-ps.com/rohs

OUTPUT RIPPLE REDUCTION

By using the values of inductance and capacitance stated, the output ripple at the rated load is lowered to 5mV p-p max.

Component selection

Capacitor: It is required that the ESR (Equivalent Series Resistance) should be as low as possible, ceramic types are recommended. The voltage rating should be at least twice (except for 15V output), the rated output voltage of the DC/DC converter.

Inductor: The rated current of the inductor should not be less than that of the output of the DC/DC converter. At the rated current, the DC resistance of the inductor should be such that the voltage drop across the inductor is <2% of the rated voltage of the DC/DC converter. The SRF (Self Resonant Frequency) should be >20MHz.

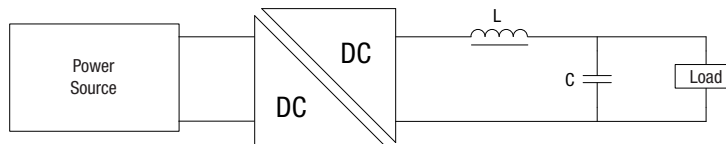

| | Inductor | | | Capacitor |
|--------------------------|------------|--------------|--------|------------|
| | L, μ H | Through Hole | SMD | C, μ F |
| 3.3V single output types | 22 | 22R223C | 82223C | 4.7 |
| 5V single output types | 22 | 22R223C | 82223C | 4.7 |
| 9V single output types | 47 | 22R473C | 82473C | 2.2 |
| 12V single output types | 220 | 22R224C | 82224C | 0.47 |
| 15V single output types | 220 | 22R224C | 82224C | 0.47 |

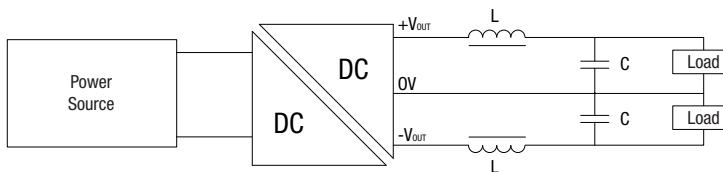

| | Inductor | | | Capacitor |
|-----------------------|------------|--------------|--------|------------|
| | L, μ H | Through Hole | SMD | C, μ F |
| 5V dual output types | 22 | 22R223C | 82223C | 4.70 |
| 9V dual output types | 47 | 22R473C | 82473C | 2.2 |
| 12V dual output types | 220 | 22R224C | 82224C | 0.47 |
| 15V dual output types | 220 | 22R224C | 82224C | 0.47 |

Capacitive loading and start up

Typical start up times for this series, with a typical input voltage rise time of 2.2 μ s and output capacitance of 10 μ F, are shown in the table below. The product series will start into a capacitance of 47 μ F with an increased start time, however, the maximum recommended output capacitance is 10 μ F.

| | Start-up time | | Start-up time |
|------------|---------------|------------|---------------|
| | μ s | | μ s |
| NMJ0505SC | 2530 | NMJ0505SAC | 1059 |
| NMJ0509SC | 7865 | NMJ0509SAC | 3454 |
| NMJ0512SC | 13080 | NMJ0512SAC | 7980 |
| NMJ0515SC | 21560 | NMJ0515SAC | 11505 |
| NMJ1205SC | 2770 | NMJ1205SAC | 1286 |
| NMJ1209SC | 20455 | NMJ1209SAC | 3548 |
| NMJ1212SC | 14475 | NMJ1212SAC | 7355 |
| NMJ1215SC | 22300 | NMJ1215SAC | 11535 |
| NMJ0303SAC | 530 | | |
| NMJ0503SAC | 576 | | |

Typical Start-Up Wave Form

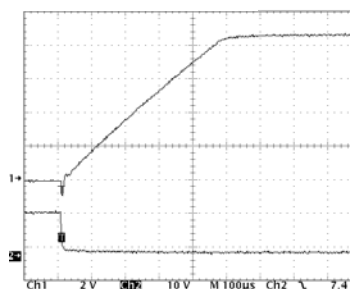

OUTPUT RIPPLE REDUCTION (continued)

Minimum load

The minimum load to meet datasheet specification is 10% of the full rated load across the specified input voltage range. Lower than 10% minimum loading will result in an increase in output voltage, which may rise to typically double the specified output voltage if the output load falls to less than 5%.

SMD option 8200 Inductor Series Mechanical Dimensions

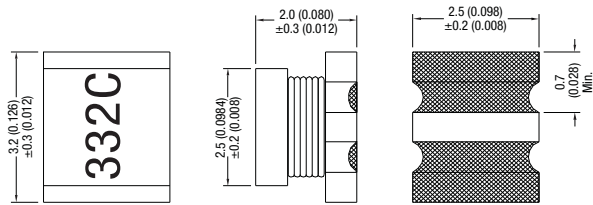

Recommended pad layout

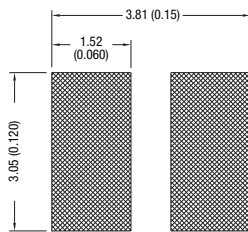

All dimensions in inches (mm).

For more information please visit www.murata-ps.com

Through hole option 2200R Inductor Series Mechanical Dimensions

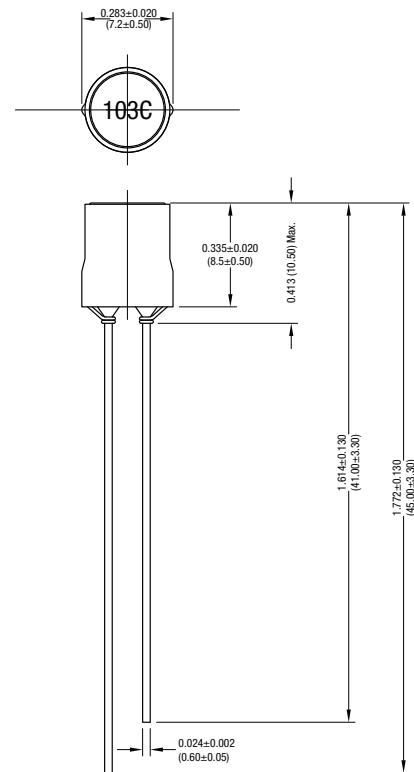

Recommended footprint

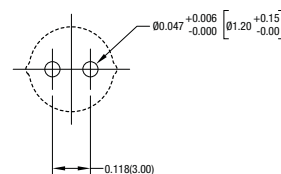

All dimensions in inches (mm).

CHARACTERISATION TEST METHODS

Ripple & Noise Characterisation Method

Ripple and noise measurements are performed with the following test configuration.

| | |
|-------|--|
| C1 | 1 μ F X7R multilayer ceramic capacitor, voltage rating to be a minimum of 3 times the output voltage of the DC/DC converter |
| C2 | 10 μ F tantalum capacitor, voltage rating to be a minimum of 1.5 times the output voltage of the DC/DC converter with an ESR of less than 100m Ω at 100 kHz |
| C3 | 100nF multilayer ceramic capacitor, general purpose |
| R1 | 450 Ω resistor, carbon film, \pm 1% tolerance |
| R2 | 50 Ω BNC termination |
| T1 | 3T of the coax cable through a ferrite toroid |
| RLOAD | Resistive load to the maximum power rating of the DC/DC converter. Connections should be made via twisted wires |

Measured values are multiplied by 10 to obtain the specified values.

Differential Mode Noise Test Schematic

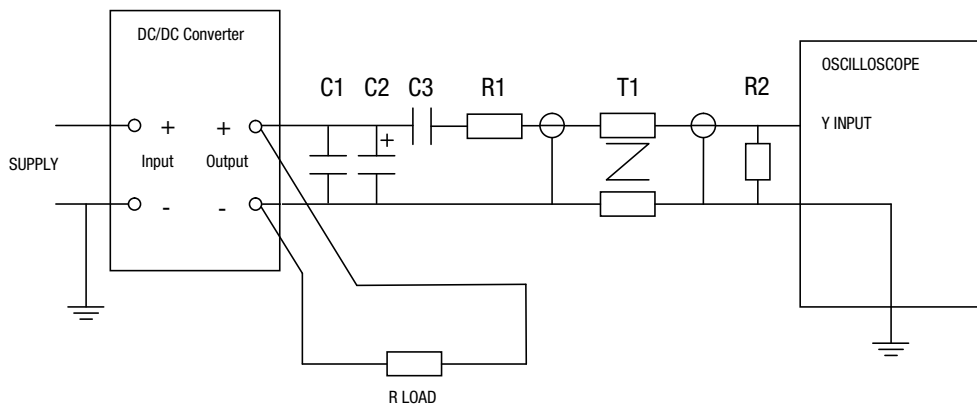

PACKAGE SPECIFICATIONS

MECHANICAL DIMENSIONS

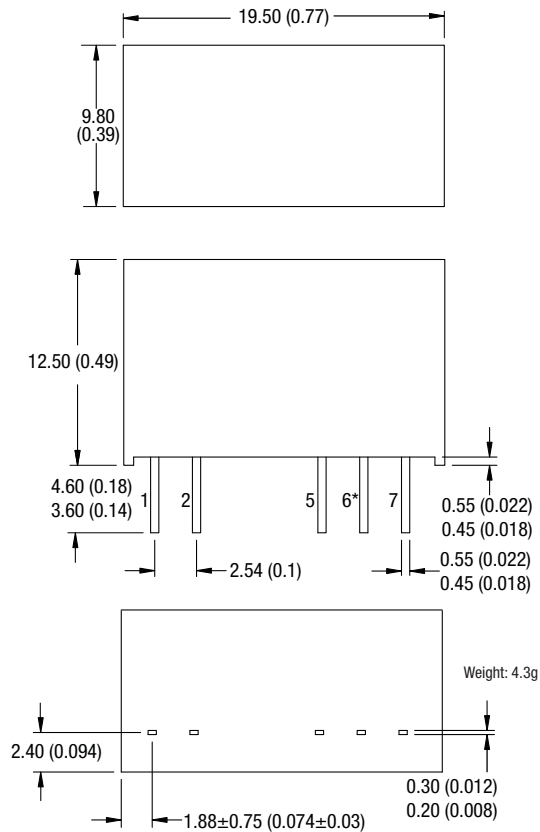

All dimensions in mm ±0.25mm (inches ±0.01). All pins on a 2.54 (0.1) pitch and within ±0.25 (0.01) of true position.
 * Pin not fitted on single output variants.

PIN CONNECTIONS

Dual Output

| Pin | Function |
|-----|----------|
| 1 | +VIN |
| 2 | -VIN |
| 5 | -VOUT |
| 6 | OV |
| 7 | +VOUT |

Single Output

| Pin | Function |
|-----|----------|
| 1 | +VIN |
| 2 | -VIN |
| 5 | -VOUT |
| 7 | +VOUT |

RECOMMENDED FOOTPRINT DETAILS

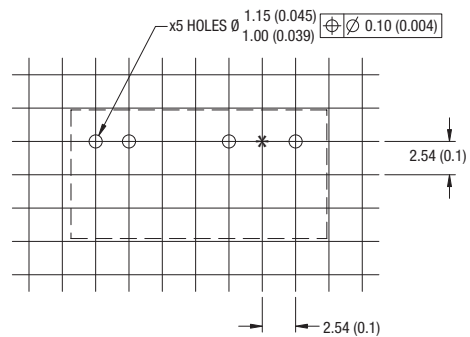

* Hole not required for single output variants.
 All dimensions in mm ±0.25mm (inches ±0.01).

TUBE OUTLINE DIMENSIONS

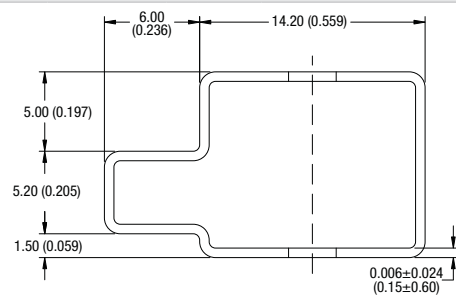

Unless otherwise stated all dimensions in mm ±0.5mm (inches ±0.02).
 Tube length : 525mm±2mm (20.669±0.079).

Tube Quantity : 25

Murata Power Solutions, Inc.
 11 Cabot Boulevard, Mansfield, MA 02048-1151 U.S.A.
 ISO 9001 and 14001 REGISTERED



This product is subject to the following **operating requirements** and the **Life and Safety Critical Application Sales Policy**:
 Refer to: <http://www.murata-ps.com/requirements/>

Murata Power Solutions, Inc. makes no representation that the use of its products in the circuits described herein, or the use of other technical information contained herein, will not infringe upon existing or future patent rights. The descriptions contained herein do not imply the granting of licenses to make, use, or sell equipment constructed in accordance therewith. Specifications are subject to change without notice.
 © 2012 Murata Power Solutions, Inc.



Компания «ЭлектроПласт» предлагает заключение долгосрочных отношений при поставках импортных электронных компонентов на взаимовыгодных условиях!

Наши преимущества:

- Оперативные поставки широкого спектра электронных компонентов отечественного и импортного производства напрямую от производителей и с крупнейших мировых складов;
- Поставка более 17-ти миллионов наименований электронных компонентов;
- Поставка сложных, дефицитных, либо снятых с производства позиций;
- Оперативные сроки поставки под заказ (от 5 рабочих дней);
- Экспресс доставка в любую точку России;
- Техническая поддержка проекта, помощь в подборе аналогов, поставка прототипов;
- Система менеджмента качества сертифицирована по Международному стандарту ISO 9001;
- Лицензия ФСБ на осуществление работ с использованием сведений, составляющих государственную тайну;
- Поставка специализированных компонентов (Xilinx, Altera, Analog Devices, Intersil, Interpoint, Microsemi, Aeroflex, Peregrine, Syfer, Eurofarad, Texas Instrument, Miteq, Cobham, E2V, MA-COM, Hittite, Mini-Circuits, General Dynamics и др.);

Помимо этого, одним из направлений компании «ЭлектроПласт» является направление «Источники питания». Мы предлагаем Вам помощь Конструкторского отдела:

- Подбор оптимального решения, техническое обоснование при выборе компонента;
- Подбор аналогов;
- Консультации по применению компонента;
- Поставка образцов и прототипов;
- Техническая поддержка проекта;
- Защита от снятия компонента с производства.



Как с нами связаться

Телефон: 8 (812) 309 58 32 (многоканальный)

Факс: 8 (812) 320-02-42

Электронная почта: org@eplast1.ru

Адрес: 198099, г. Санкт-Петербург, ул. Калинина, дом 2, корпус 4, литера А.