

NCP431A, SC431A, NCP431B, NCP432B Series

Programmable Precision References

The NCP431/NCP432 integrated circuits are three-terminal programmable shunt regulator diodes. These monolithic IC voltage references operate as a low temperature coefficient zener which is programmable from V_{ref} to 36 V using two external resistors. These devices exhibit a wide operating current range of 40 μA to 100 mA with a typical dynamic impedance of 0.22 Ω . The characteristics of these references make them excellent replacements for zener diodes in many applications such as digital voltmeters, power supplies, and op amp circuitry. The 2.5 V reference makes it convenient to obtain a stable reference from 5.0 V logic supplies, and since the NCP431/NCP432 operates as a shunt regulator, it can be used as either a positive or negative voltage reference. Low minimum operating current makes this device an ideal choice for secondary regulators in SMPS adapters with extremely low no-load consumption.

Features

- Programmable Output Voltage to 36 V
- Low Minimum Operating Current: 40 μA , Typ @ 25°C
- Voltage Reference Tolerance: $\pm 0.5\%$, Typ @ 25°C (NCP431B/NCP432B)
- Low Dynamic Output Impedance, 0.22 Ω Typical
- Sink Current Capability of 40 μA to 100 mA
- Equivalent Full-Range Temperature Coefficient of 50 ppm/°C Typical
- Temperature Compensated for Operation over Full Rated Operating Temperature Range
- SC Prefix for Automotive and Other Applications Requiring Unique Site and Control Change Requirements; AEC-Q100 Qualified and PPAP Capable
- These are Pb-Free Devices

Typical Applications

- Voltage Adapters
- Switching Power Supply
- Precision Voltage Reference
- Charger
- Instrumentation



ON Semiconductor®

<http://onsemi.com>

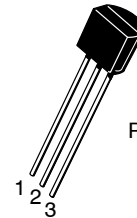

TO-92
LP SUFFIX
CASE 29-11

Pin 1. Reference
2. Anode
3. Cathode



SOIC-8 NB
D SUFFIX
CASE 751

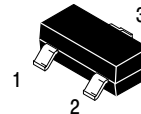
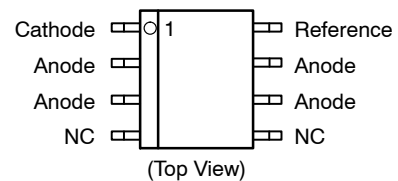

SOT-23-3
SN SUFFIX
CASE 318

NCP431
Pin 1. Reference
2. Cathode
3. Anode

NCP432
Pin 1. Cathode
2. Reference
3. Anode

ORDERING AND MARKING INFORMATION

See detailed ordering and shipping information in the package dimensions section on page 14 of this data sheet.

NCP431A, SC431A, NCP431B, NCP432B Series

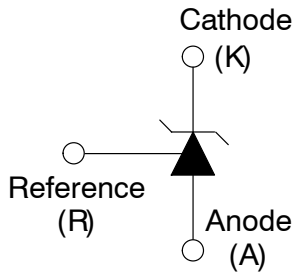

Figure 1. Symbol

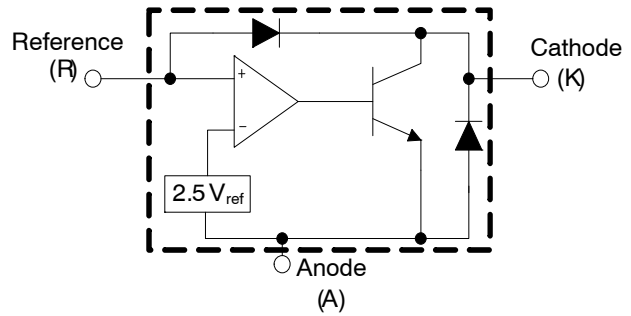

Figure 2. Representative Block diagram

MAXIMUM RATINGS (Full operating ambient temperature range applies, unless otherwise noted)

Symbol	Rating	Value	Unit
V_{KA}	Cathode to Anode Voltage	37	V
I_K	Cathode Current Range, Continuous	-100 to +150	mA
I_{ref}	Reference Input Current Range, Continuous	-0.05 to +10	mA
T_J	Operating Junction Temperature	150	°C
T_A	Operating Ambient Temperature Range	-40 to +125	°C
T_{stg}	Storage Temperature Range	-65 to +150	°C
P_D	Total Power Dissipation @ $T_A = 25^\circ\text{C}$ Derate above 25°C Ambient Temperature D, LP Suffix Plastic Package SN1 Suffix Plastic Package	0.70 0.52	W
P_D	Total Power Dissipation @ $T_C = 25^\circ\text{C}$ Derate above 25°C Case Temperature D, LP Suffix Plastic Package	1.5	W
HBM MM	ESD Rating	>2000 >200	V

Stresses exceeding Maximum Ratings may damage the device. Maximum Ratings are stress ratings only. Functional operation above the Recommended Operating Conditions is not implied. Extended exposure to stresses above the Recommended Operating Conditions may affect device reliability.

RECOMMENDED OPERATING CONDITIONS

Symbol	Condition	Min	Max	Unit
V_{KA}	Cathode to Anode Voltage	V_{ref}	36	V
I_K	Cathode Current	0.04	100	mA

THERMAL CHARACTERISTICS

Symbol	Characteristic	LP Suffix Package (50 mm ² x 35 μm Cu)	D Suffix Package (50 mm ² x 35 μm Cu)	SN Suffix Package (10 mm ² x 35 μm Cu)	Unit
$R_{\theta JA}$	Thermal Resistance, Junction-to-Ambient	176	210	255	°C/W
$R_{\theta JL}$	Thermal Resistance, Junction-to-Lead (Lead 3)	75	68	80	°C/W

NCP431A, SC431A, NCP431B, NCP432B Series

ELECTRICAL CHARACTERISTICS (T_A = 25°C, unless otherwise noted.)

Symbol	Characteristic	NCP431AC			NCP431AI			NCP431AV/ SC431AV			Unit
		Min	Typ	Max	Min	Typ	Max	Min	Typ	Max	
V _{ref}	Reference Input Voltage V _{KA} = V _{ref} , I _K = 1 mA T _A = 25°C T _A = T _{low} to T _{high} (Note 1)	2.475 2.475	2.500 2.500	2.525 2.525	2.475 2.465	2.500 2.500	2.525 2.525	2.475 2.460	2.500 2.500	2.525 2.525	V
ΔV _{refT}	Reference Input Voltage Deviation Over Temperature Range (Figure 1, Notes 2, 3) V _{KA} = V _{ref} , I _K = 1 mA	-	-	-	-	5.0	10	-	10	15	mV
$\frac{\Delta V_{ref}}{\Delta V_{AK}}$	Ratio of Change in Reference Input Voltage to Change in Cathode to Anode Voltage I _K = 1 mA (Figure 2), ΔV _{KA} = 10 V to V _{ref} ΔV _{KA} = 36 V to 10 V	-	-2.00 -1.28	-3.1 -1.9	-	-2.00 -1.28	-3.1 -1.9	-	-2.00 -1.28	-3.1 -1.9	mV/ V
I _{ref}	Reference Input Current (Figure 2) I _K = 1 mA, R1 = 220 k, R2 = ∞ T _A = -40°C to +125°C	-	81	190	-	81	190	-	81	190	nA
ΔI _{refT}	Reference Input Current Deviation Over Temperature Range (Figure 2, Note 2, 3) I _K = 1 mA, R1 = 10 k, R2 = ∞	-	22	55	-	22	55	-	22	55	nA
I _{min}	Minimum Cathode Current For Regulation V _{KA} = V _{ref} (Figure 1)	-	40	80	-	40	80	-	40	80	μA
I _{off}	Off-State Cathode Current (Figure 3) V _{KA} = 36 V, V _{ref} = 0 V	-	180	1000	-	180	1000	-	180	1000	nA
Z _{KA}	Dynamic Impedance (Figure 1, Note 3) V _{KA} = V _{ref} , ΔI _K = 1.0 mA to 100 mA f ≤ 1.0 kHz	-	0.22	0.5	-	0.22	0.5	-	0.22	0.5	Ω

- T_{low} = -40°C for NCP431AI, NCP431AV, SC431AV
= 0°C for NCP431AC
T_{high} = 70°C for NCP431AC
= 85°C for NCP431AI
= 125°C for NCP431AV, SC431AV
- Guaranteed by design
- The deviation parameter ΔV_{refT} is defined as the difference between the maximum and minimum values obtained over the full operating ambient temperature range that applies.

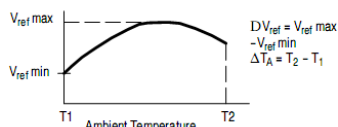

The average temperature coefficient of the reference input voltage, V_{ref} is defined as:

$$V_{ref} \frac{\text{ppm}}{^{\circ}\text{C}} = \frac{\left(\frac{\Delta V_{ref}}{V_{ref@25^{\circ}\text{C}}} \right) \times 10^6}{\Delta T_A} = \frac{\Delta V_{ref} \times 10^6}{\Delta T_A (V_{ref@25^{\circ}\text{C}})}$$

αV_{ref} can be positive or negative depending on whether V_{ref} Min or V_{ref} Max occurs at the lower ambient temperature.

Example: ΔV_{refT} = 17 mV and slope is positive
V_{ref} = 2.5 V, ΔT_A = 165°C (from -40°C to +125°C)

$$\alpha V_{ref} = \frac{0.017 \cdot 10^6}{165 \cdot 2.5} = 41.2 \text{ ppm}/^{\circ}\text{C}$$

- The dynamic impedance Z_{KA} is defined as: (|Z_{KA}| = (ΔV_{KA}/ΔI_K)). When the device is programmed with two external resistors, R1 and R2, the total dynamic impedance of the circuit is defined as: |Z_{KA}'| ≈ |Z_{KA}| (1 + (R1/R2)).
- SC431AVSNT1G – T_{low} = -40°C, T_{high} = 125°C. Guaranteed by design. SC Prefix for Automotive and Other Applications Requiring Unique Site and Control Change Requirements; AEC-Q100 Qualified and PPAP Capable.

NCP431A, SC431A, NCP431B, NCP432B Series

ELECTRICAL CHARACTERISTICS (T_A = 25°C, unless otherwise noted.)

Symbol	Characteristic	NCP431BC NCP432BC			NCP431BI NCP432BI			NCP431BV NCP432BV			Unit
		Min	Typ	Max	Min	Typ	Max	Min	Typ	Max	
V _{ref}	Reference Input Voltage V _{KA} = V _{ref} , I _K = 1 mA T _A = 25°C T _A = T _{low} to T _{high} (Note 6)	2.4875 2.4875	2.500 2.500	2.5125 2.5125	2.4875 2.4775	2.500 2.500	2.5125 2.5125	2.4875 2.4725	2.500 2.500	2.5125 2.5125	V
ΔV _{refT}	Reference Input Voltage Deviation Over Temperature Range (Figure 1, Notes 7, 8) V _{KA} = V _{ref} , I _K = 1 mA	-	-	-	-	5.0	10	-	10	15	mV
$\frac{\Delta V_{ref}}{\Delta V_{AK}}$	Ratio of Change in Reference Input Voltage to Change in Cathode to Anode Voltage I _K = 1 mA (Figure 2), ΔV _{KA} = 10 V to V _{ref} ΔV _{KA} = 36 V to 10 V	-	-2.00 -1.28	-3.1 -1.9	-	-2.00 -1.28	-3.1 -1.9	-	-2.00 -1.28	-3.1 -1.9	mV/V
I _{ref}	Reference Input Current (Figure 2) I _K = 1 mA, R1 = 220 k, R2 = ∞ T _A = -40°C to +125°C	-	81	190	-	81	190	-	81	190	nA
ΔI _{refT}	Reference Input Current Deviation Over Temperature Range (Figure 2, Note 7, 8) I _K = 1 mA, R1 = 10 k, R2 = ∞	-	22	55	-	22	55	-	22	55	nA
I _{min}	Minimum Cathode Current For Regulation V _{KA} = V _{ref} (Figure 1)	-	40	80	-	40	80	-	40	80	μA
I _{off}	Off-State Cathode Current (Figure 3) V _{KA} = 36 V, V _{ref} = 0 V	-	180	1000	-	180	1000	-	180	1000	nA
Z _{KA}	Dynamic Impedance (Figure 1, Note 8) V _{KA} = V _{ref} , ΔI _K = 1.0 mA to 100 mA f ≤ 1.0 kHz	-	0.22	0.5	-	0.22	0.5	-	0.22	0.5	Ω

6. T_{low} = -40°C for NCP431BI, NCP431BV, NCP432BI, NCP432BV
 = 0°C for NCP431BC, NCP432BC
 T_{high} = 70°C for NCP431BC, NCP432BC
 = 85°C for NCP431BI, NCP432BI
 = 125°C for NCP431BV, NCP432BV

7. Guaranteed by design

8. The deviation parameter ΔV_{refT} is defined as the difference between the maximum and minimum values obtained over the full operating ambient temperature range that applies.

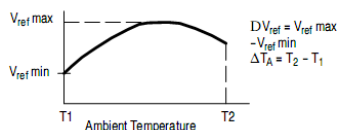

The average temperature coefficient of the reference input voltage, V_{ref} is defined as:

$$V_{ref} \frac{\text{ppm}}{^{\circ}\text{C}} = \frac{\left(\frac{\Delta V_{ref}}{V_{ref@25^{\circ}\text{C}}} \right) \times 10^6}{\Delta T_A} = \frac{\Delta V_{ref} \times 10^6}{\Delta T_A (V_{ref@25^{\circ}\text{C}})}$$

αV_{ref} can be positive or negative depending on whether V_{ref} Min or V_{ref} Max occurs at the lower ambient temperature.

Example: ΔV_{refT} = 17 mV and slope is positive
 V_{ref} = 2.5 V, ΔT_A = 165°C (from -40°C to +125°C)

$$\alpha V_{ref} = \frac{0.017 \cdot 10^6}{165 \cdot 2.5} = 41.2 \text{ ppm}/^{\circ}\text{C}$$

9. The dynamic impedance Z_{KA} is defined as: |Z_{KA}| = (ΔV_{KA}/ΔI_K). When the device is programmed with two external resistors, R1 and R2, the total dynamic impedance of the circuit is defined as: |Z_{KA}| ≈ |Z_{KA}| (1 + (R1/R2))

NCP431A, SC431A, NCP431B, NCP432B Series

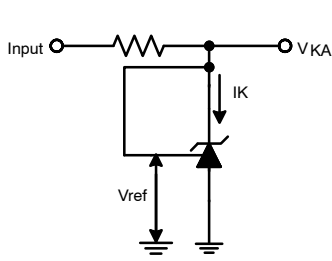

Figure 3. Test Circuit for $V_{KA} = V_{ref}$

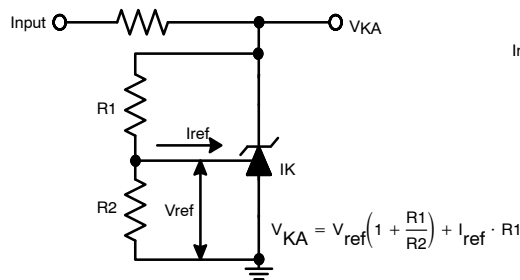

Figure 4. Test Circuit for $V_{KA} > V_{ref}$

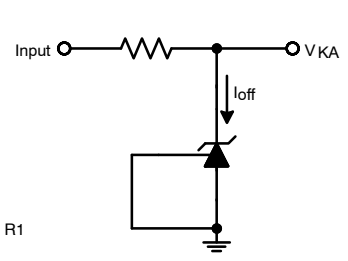

Figure 5. Test Circuit for I_{off}

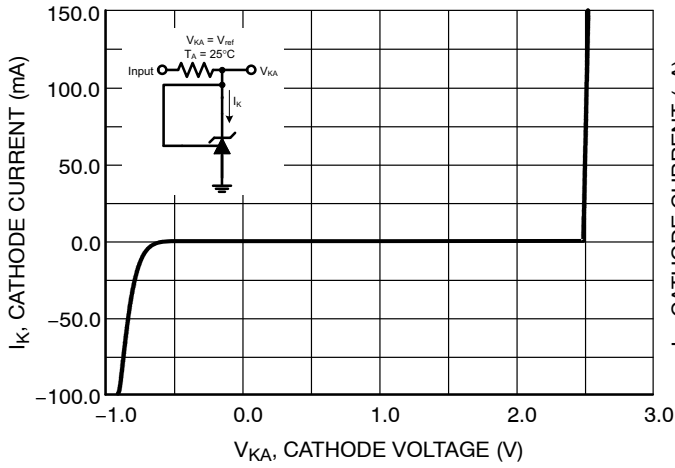

Figure 6. Cathode Current versus Cathode Voltage

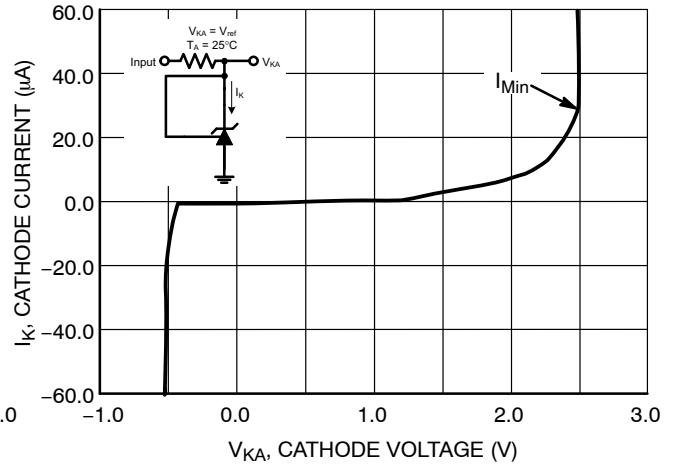

Figure 7. Cathode Current versus Cathode Voltage

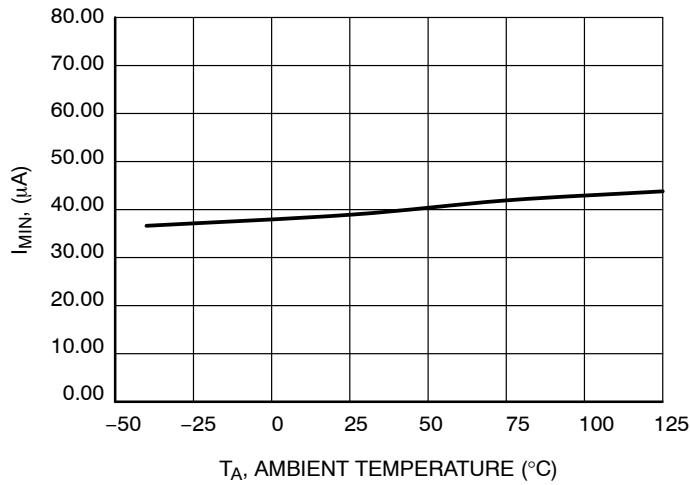

Figure 8. Minimum Cathode Current Regulation versus Ambient Temperature

NCP431A, SC431A, NCP431B, NCP432B Series

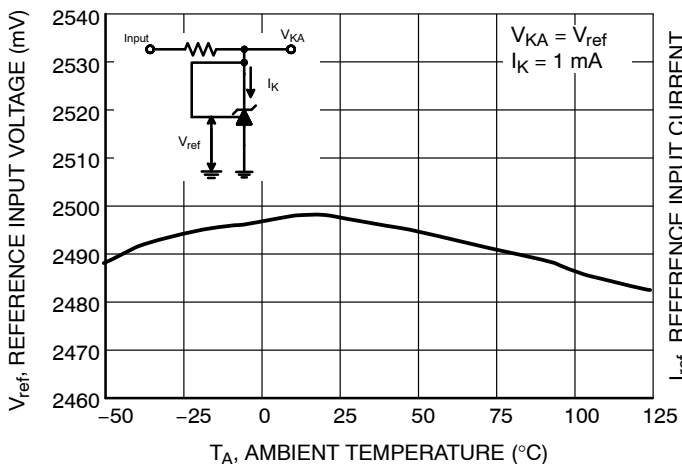

Figure 9. Reference Input Voltage versus Ambient temperature

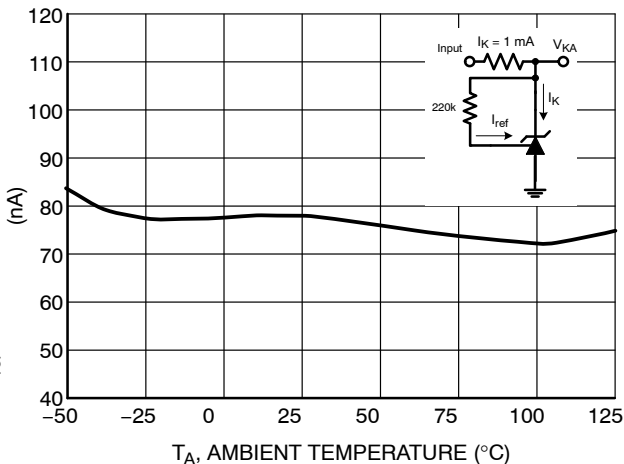

Figure 10. Reference Input Current versus Ambient temperature

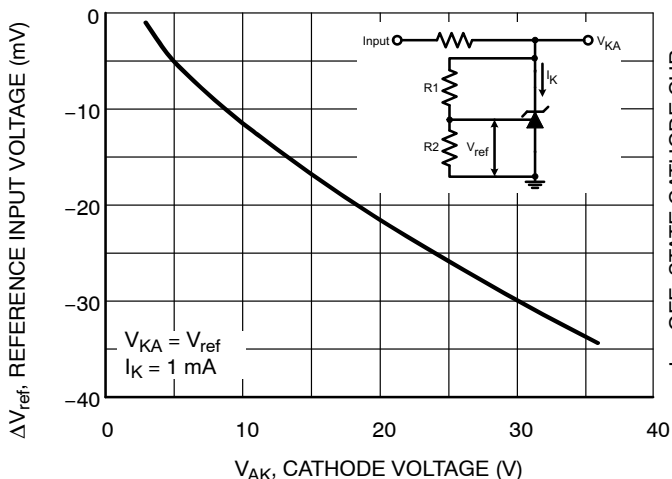

Figure 11. Change in Reference Input Voltage versus Cathode Voltage

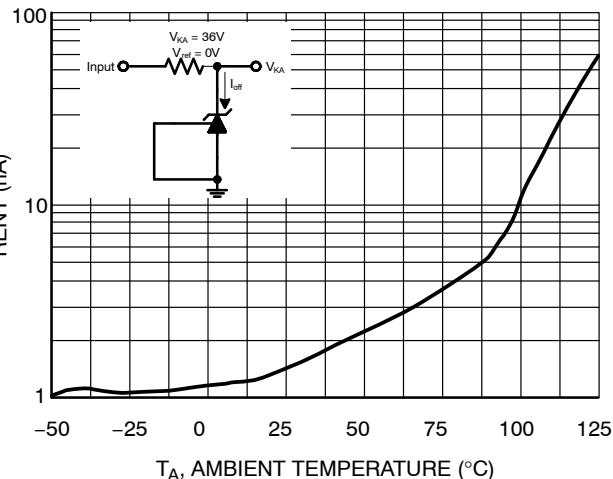

Figure 12. Off-State Cathode Current versus Ambient Temperature

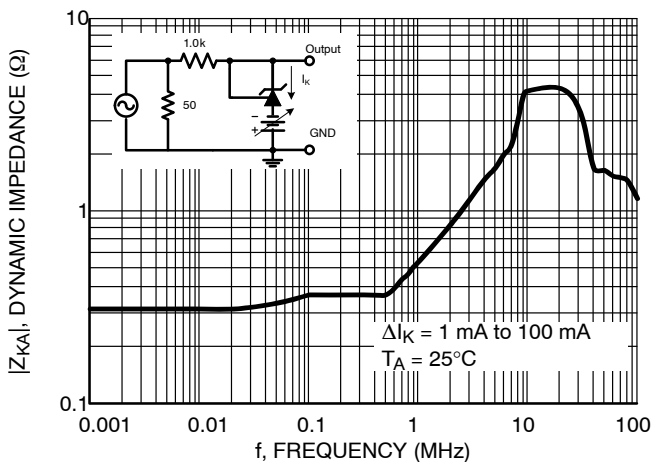

Figure 13. Dynamic Impedance versus Frequency

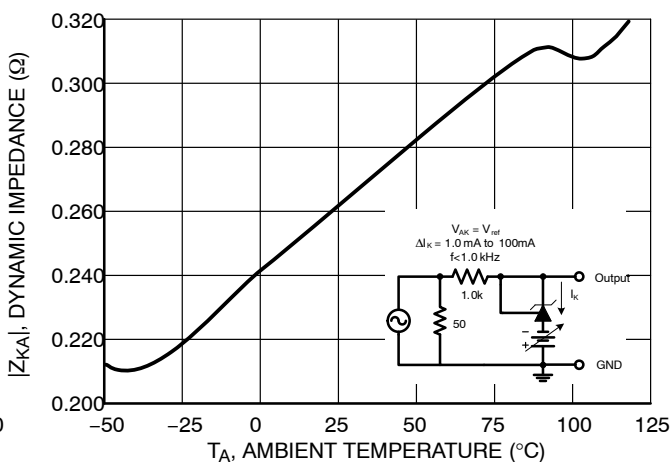

Figure 14. Dynamic Impedance versus Ambient Temperature

NCP431A, SC431A, NCP431B, NCP432B Series

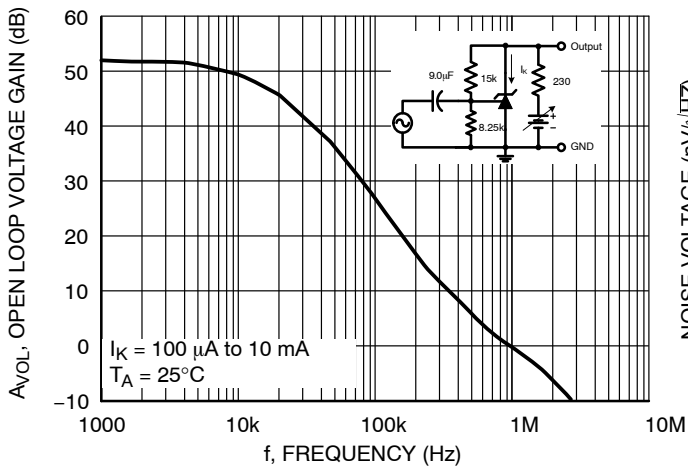

Figure 15. Open-Loop Voltage Gain versus Frequency

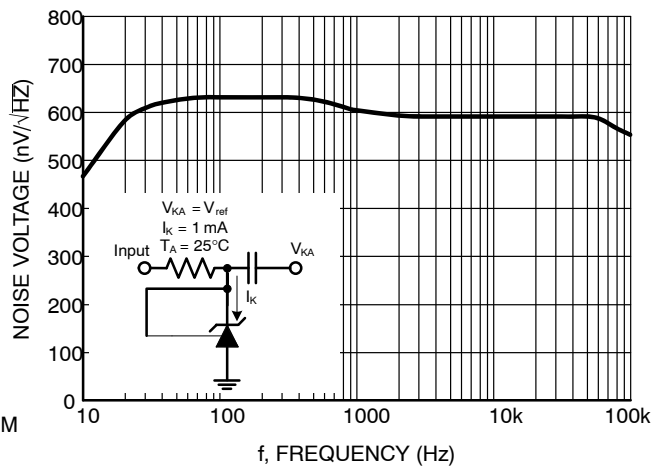

Figure 16. Spectral Noise Density

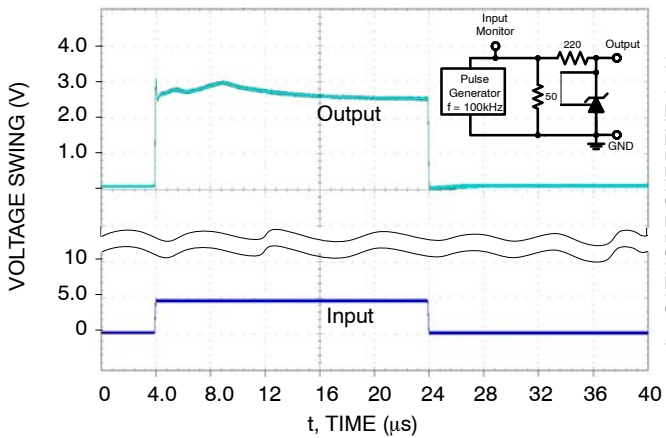

Figure 17. Pulse Response

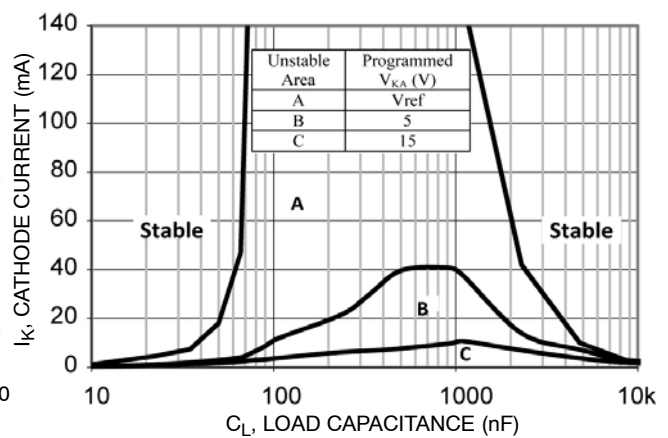

Figure 18. Stability Boundary Conditions

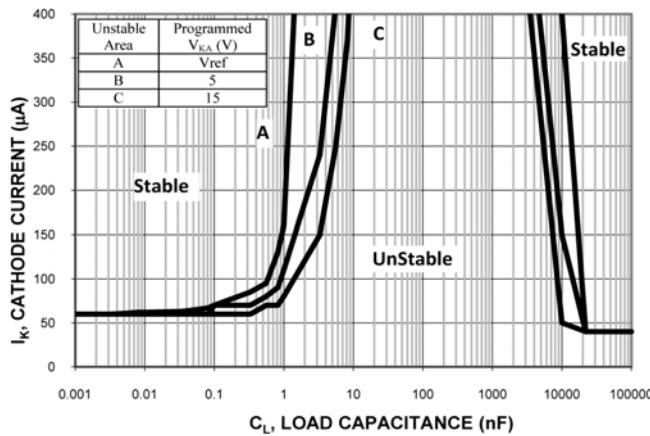

Figure 19. Stability Boundary Conditions for Small Cathode Current

NCP431A, SC431A, NCP431B, NCP432B Series

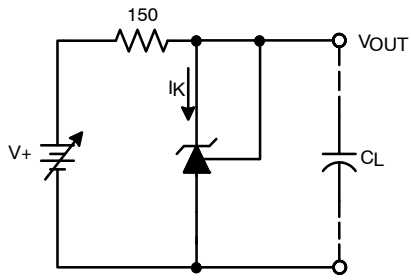

Figure 20. Test Circuit For Curve A of Stability Boundary Conditions

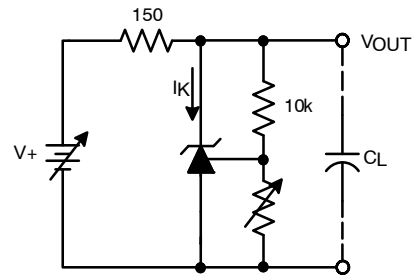
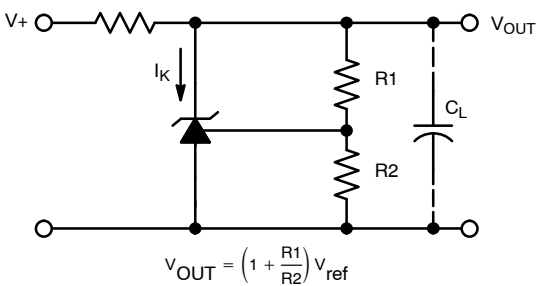

Figure 21. Test Circuit For Curve B And C of Stability Boundary Conditions

TYPICAL APPLICATIONS



$$V_{OUT} = \left(1 + \frac{R1}{R2}\right) V_{ref}$$

Figure 22. Shunt Regulator

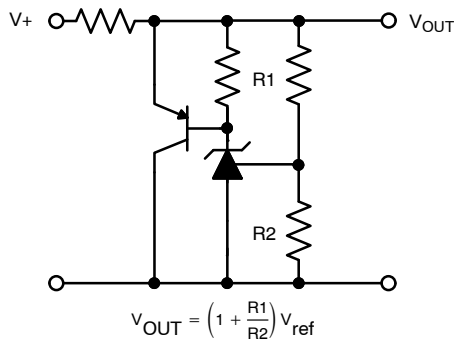

$$V_{OUT} = \left(1 + \frac{R1}{R2}\right) V_{ref}$$

Figure 23. High Current Shunt Regulator

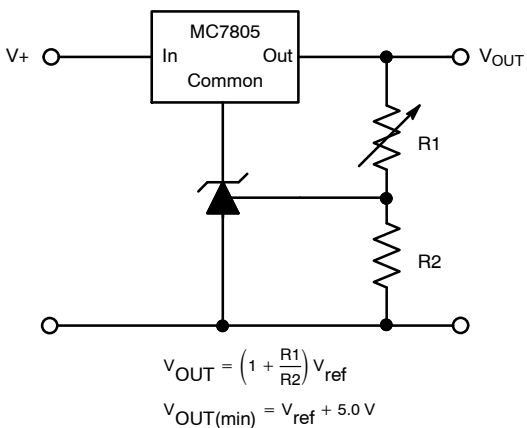

$$V_{OUT} = \left(1 + \frac{R1}{R2}\right) V_{ref}$$

$$V_{OUT(min)} = V_{ref} + 5.0V$$

Figure 24. Output Control for a Tree-Terminal Fixed Regulator

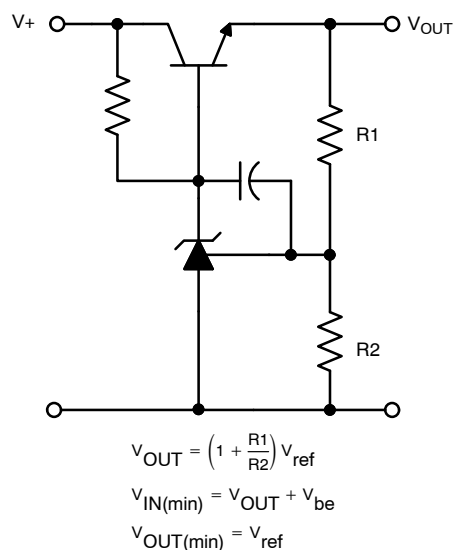

$$V_{OUT} = \left(1 + \frac{R1}{R2}\right) V_{ref}$$

$$V_{IN(min)} = V_{OUT} + V_{be}$$

$$V_{OUT(min)} = V_{ref}$$

Figure 25. Series Pass Regulator

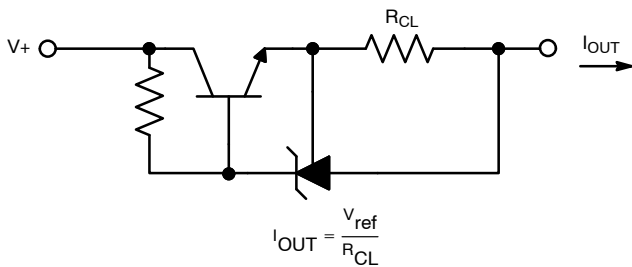

$$I_{OUT} = \frac{V_{ref}}{R_{CL}}$$

Figure 26. Constant Current Source

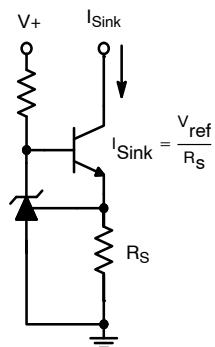

$$I_{Sink} = \frac{V_{ref}}{R_S}$$

Figure 27. Constant Current Sink

NCP431A, SC431A, NCP431B, NCP432B Series

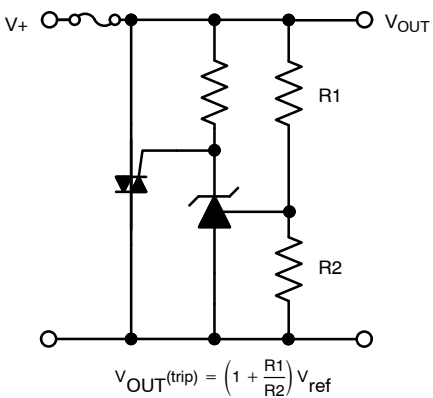

Figure 28. Triac Crowbar

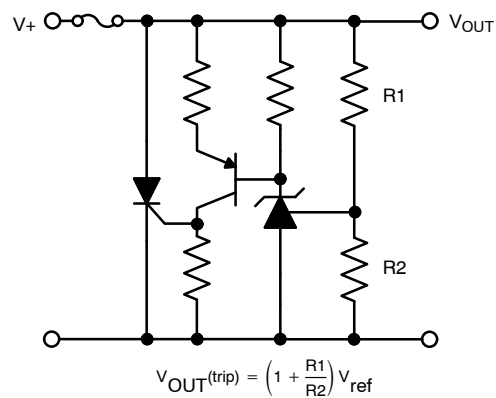
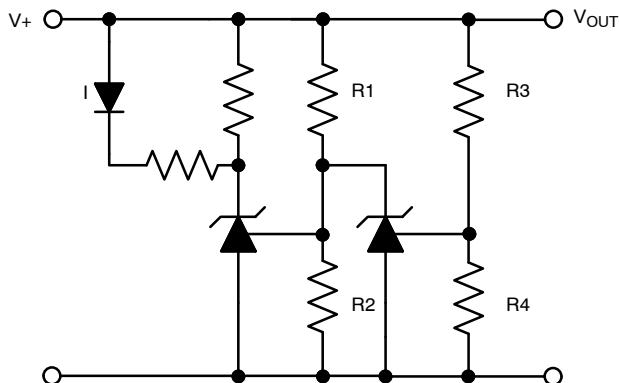

Figure 29. SRC Crowbar



L.E.D. indicator is 'on' when V+ is between the upper and lower limits.

Figure 30. Voltage Monitoring

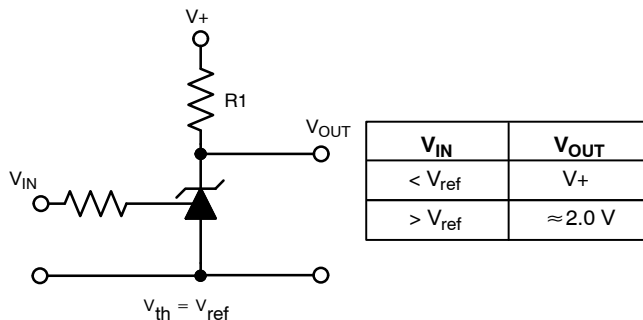

Figure 31. Single-Supply Comparator with Temperature-Compensated Threshold

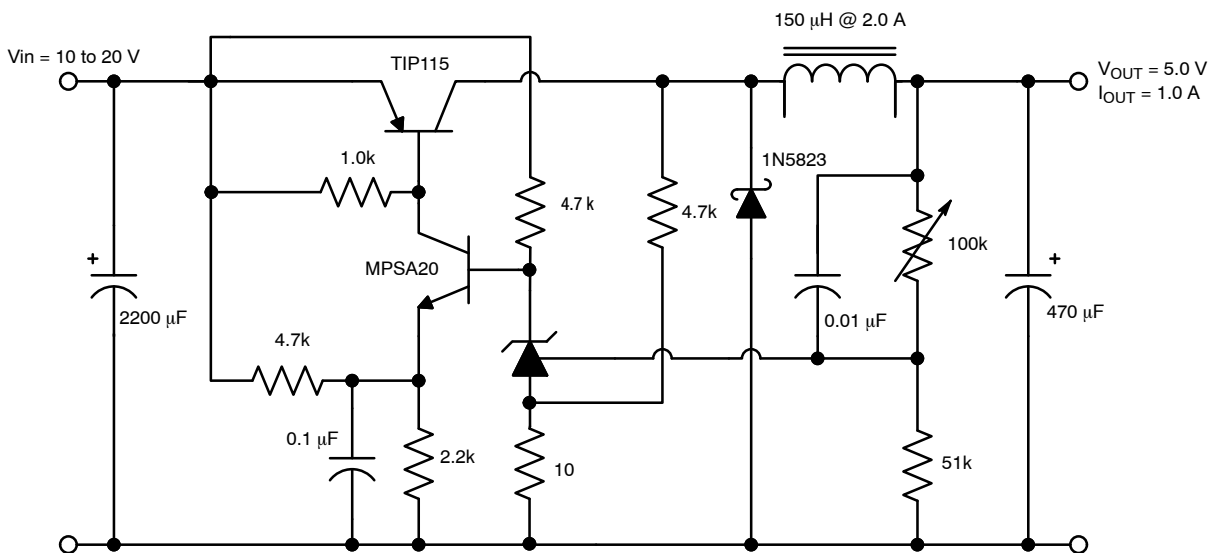

Figure 32. Step-Down Switching Converter

APPLICATIONS INFORMATION

The NCP431/NCP432 is a programmable precision reference which is used in a variety of ways. It serves as a reference voltage in circuits where a non-standard reference voltage is needed. Other uses include feedback control for driving an optocoupler in power supplies, voltage monitor, constant current source, constant current sink and series pass regulator. In each of these applications, it is critical to maintain stability of the device at various operating currents and load capacitances. In some cases the circuit designer can estimate the stabilization capacitance from the stability boundary conditions curve provided in Figure 18. However, these typical curves only provide stability information at specific cathode voltages and at a specific load condition. Additional information is needed to determine the capacitance needed to optimize phase margin or allow for process variation.

A simplified model of the NCP431/NCP432 is shown in Figure 33. When tested for stability boundaries, the load resistance is 150 Ω. The model reference input consists of an input transistor and a dc emitter resistance connected to the device anode. A dependent current source, G_m, develops a current whose amplitude is determined by the difference between the 1.78 V internal reference voltage source and the input transistor emitter voltage. A portion of G_m flows through compensation capacitance, CP2. The voltage across CP2 drives the output dependent current source, Go, which is connected across the device cathode and anode.

Model component values are:

$$V_{ref} = 1.78 \text{ V}$$

$$G_m = 0.3 + 2.7 \exp(-I_C/26 \text{ mA})$$

where I_C is the device cathode current and G_m is in mhos

$$G_o = 1.25 (V_{cp2}) \mu\text{mhos.}$$

Resistor and capacitor typical values are shown on the model. Process tolerances are ±20% for resistors, ±10% for capacitors, and ±40% for transconductances.

An examination of the device model reveals the location of circuit poles and zeroes:

$$P_1 = \frac{1}{2\pi R_{GM} C_{P1}} = \frac{1}{2\pi \cdot 1.0M \cdot 20 \text{ pF}} = 7.96 \text{ kHz}$$

$$P_2 = \frac{1}{2\pi R_{P2} C_{P2}} = \frac{1}{2\pi \cdot 10M \cdot 0.265 \text{ pF}} = 60 \text{ kHz}$$

$$Z_1 = \frac{1}{2\pi R_{Z1} C_{P1}} = \frac{1}{2\pi \cdot 15.9k \cdot 20 \text{ pF}} = 500 \text{ kHz}$$

In addition, there is an external circuit pole defined by the load:

$$P_L = \frac{1}{2\pi R_L C_L}$$

Also, the transfer dc voltage gain of the NCP431 is:

$$G = G_M R_{GM} G_o R_L$$

Example 1:

I_C=10 mA, R_L= 230 Ω, C_L= 0. Define the transfer gain.

The DC gain is:

$$G = G_M R_{GM} G_o R_L = (2.138)(1.0M)(1.25\mu)(230) = 615 = 56 \text{ dB}$$

$$\text{Loop gain} = G \frac{8.25k}{8.25k + 15k} = 218 = 47 \text{ dB}$$

The resulting transfer function Bode plot is shown in Figure 34. The asymptotic plot may be expressed as the following equation:

$$A_v = 615 \frac{\left(1 + \frac{jf}{500 \text{ kHz}}\right)}{\left(1 + \frac{jf}{8.0 \text{ kHz}}\right)\left(1 + \frac{jf}{60 \text{ kHz}}\right)}$$

The Bode plot shows a unity gain crossover frequency of approximately 600 kHz. The phase margin, calculated from the equation, would be 55.9°. This model matches the Open-Loop Bode Plot of Figure 15. The total loop would have a unity gain frequency of about 300 kHz with a phase margin of about 44°.

NCP431A, SC431A, NCP431B, NCP432B Series

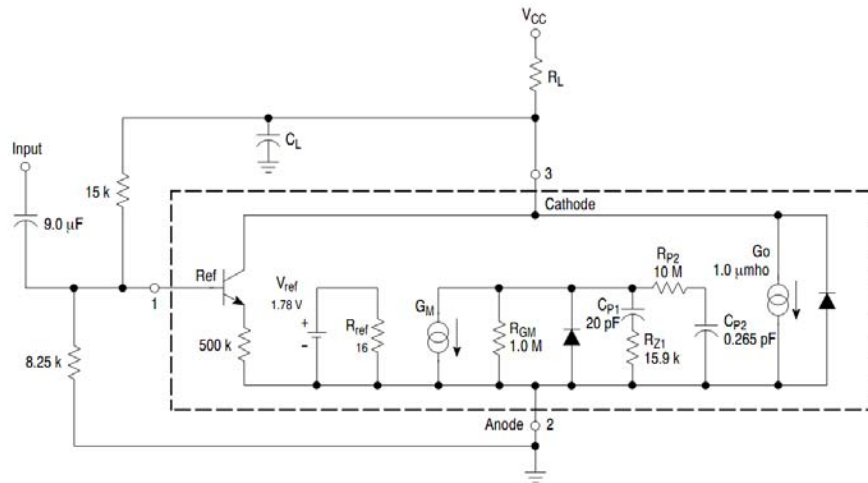

Figure 33. Simplified NCP431/NCP432 Device Model

NCP431/NCP432 OPEN-LOOP VOLTAGE GAIN VERSUS FREQUENCY

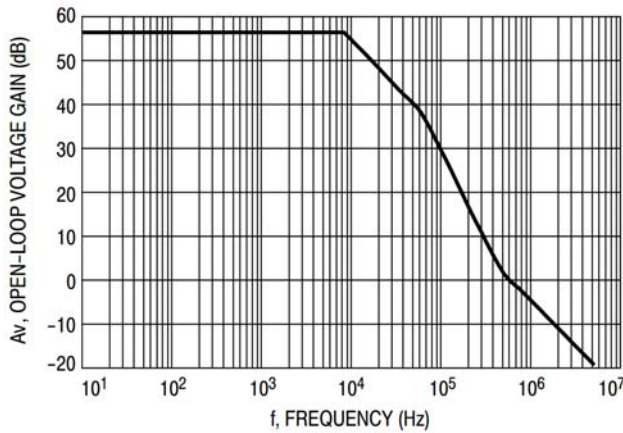

Figure 34. Example 1 Circuit Open Loop Gain Plot

Example 2.

$I_C = 7.5 \text{ mA}$, $R_L = 2.2 \text{ k}\Omega$, $C_L = 0.01 \text{ }\mu\text{F}$. Cathode tied to reference input pin. An examination of the data sheet stability boundary curve (Figure 18) shows that this value of load capacitance and cathode current is on the boundary.

Define the transfer gain.

The DC gain is:

$$G = G_M R_{GM} G_o R_L = (2.138)(1.0\text{M})(1.25\mu)(230) = 6389 = 76 \text{ dB}$$

The resulting open loop Bode plot is shown in Figure 35. The asymptotic plot may be expressed as the following equation:

$$A_v = 615 \frac{\left(1 + \frac{jf}{500 \text{ kHz}}\right)}{\left(1 + \frac{jf}{8.0 \text{ kHz}}\right)\left(1 + \frac{jf}{60 \text{ kHz}}\right)\left(1 + \frac{jf}{7.2 \text{ kHz}}\right)}$$

Note that the transfer function now has an extra pole formed by the load capacitance and load resistance.

Note that the crossover frequency in this case is about 250 kHz, having a phase margin of about -46° . Therefore, instability of this circuit is likely.

NCP431/NCP432 OPEN-LOOP BODE PLOT WITH LOAD CAP

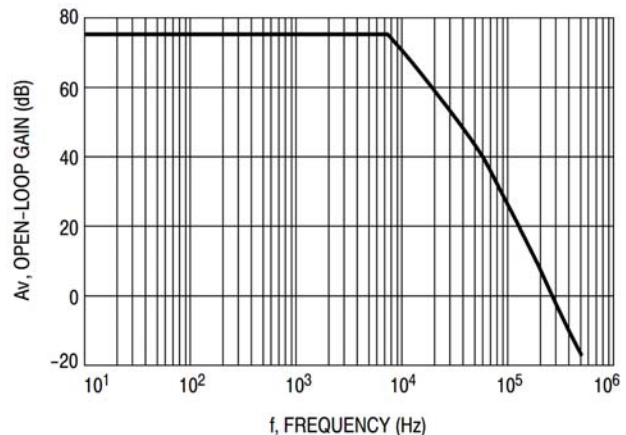

Figure 35. Example 2 Circuit Open Loop Gain Plot

With three poles, this system is unstable. The only hope for stabilizing this circuit is to add a zero. However, that can only be done by adding a series resistance to the output capacitance, which will reduce its effectiveness as a noise filter. Therefore, practically, in reference voltage applications, the best solution appears to be to use a smaller value of capacitance in low noise applications or a very large value to provide noise filtering and a dominant pole rolloff of the system.

The NCP431/NCP432 is often used as a regulator in secondary side of a switch mode power supply (SMPS).

The benefit of this reference is high and stable gain under low bias currents. Figure 36 shows dependence of the gain (dynamic impedance) on the bias current. Value of

NCP431A, SC431A, NCP431B, NCP432B Series

minimum cathode current that is needed to assure stable gain is 80 μA maximum.

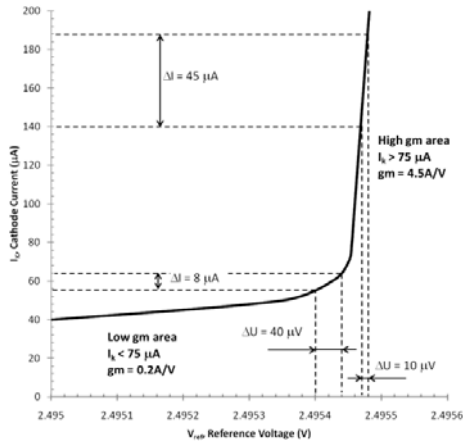

Figure 36. Knee of Reference

Regulator with TL431 or other references in secondary side of a SMPS needs bias resistor to increase cathode current to reach high and stable gain (refer to Figure 37). This bias resistor does not have to be used in regulator with NCP431/NCP432 thanks to its low minimum cathode current.

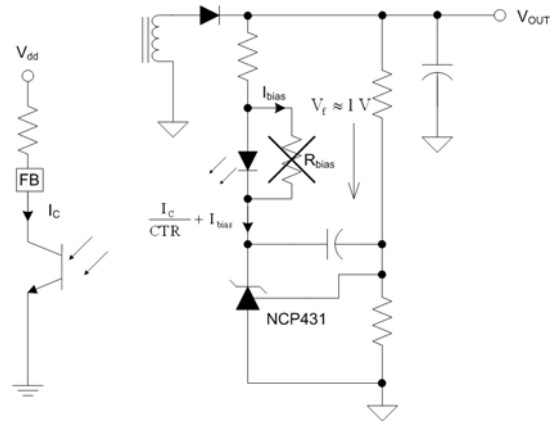

Figure 37. SMPS Secondary Side and Feedback Connection on Primary Side

The NCP431/NCP432 operates with very low leakage and reference input current. Sum of these currents is lower than 100 nA. Regulator with the NCP431/NCP432 minimizes parasitic power consumption.

The best way to achieve extremely low no-load consumption in SMPS applications is to use NCP431/NCP432 as regulator on the secondary side. The consumption is reduced by minimum parasitic consumption and very low bias current of NCP431/NCP432.

NCP431A, SC431A, NCP431B, NCP432B Series

MARKING DIAGRAMS

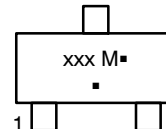
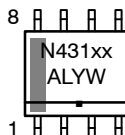
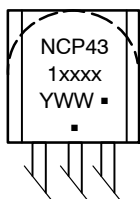

xx, xxx, xxx = Specific Device Code
 A = Assembly Location
 L = Wafer Lot
 Y = Year
 M = Date Code
 W, WW = Work Week
 ■ = Pb-Free Package

(*Note: Microdot may be in either location)

ORDERING INFORMATION

Device	Marking	Tolerance	Operating Temperature Range	Package	Shipping [†]
NCP431ACDR2G	AC	1%	0°C to 70°C	SOIC-8 (Pb-Free)	2500 / Tape & Reel
NCP431ACSNT1G	VRF	1%		SOT-23-3 (Pb-Free)	3000 / Tape & Reel
NCP431BCSNT1G	VRJ	0.5%		SOT-23-3 (Pb-Free)	3000 / Tape & Reel
NCP432BCSNT1G	VRM	0.5%		SOT-23-3 (Pb-Free)	3000 / Tape & Reel
NCP431ACLPRAG	ACLP	1%		TO-92 (TO-226) (Pb-Free)	2000 / Tape & Reel
NCP431AIDR2G	AI	1%	-40°C to 85°C	SOIC-8 (Pb-Free)	2500 / Tape & Reel
NCP431AISNT1G	VRG	1%		SOT-23-3 (Pb-Free)	3000 / Tape & Reel
NCP431BISNT1G	VRK	0.5%		SOT-23-3 (Pb-Free)	3000 / Tape & Reel
NCP432BISNT1G	VRN	0.5%		SOT-23-3 (Pb-Free)	3000 / Tape & Reel
NCP431AILPRAG	AILP	1%		TO-92 (TO-226) (Pb-Free)	2000 / Tape & Reel
NCP431AVDR2G	AV	1%	-40°C to 125°C	SOIC-8 (Pb-Free)	2500 / Tape & Reel
NCP431AVSNT1G / SC431AVSNT1G*	VRH	1%		SOT-23-3 (Pb-Free)	3000 / Tape & Reel
NCP431AVLPRAG	AVLP	1%		TO-92 (TO-226) (Pb-Free)	2000 / Tape & Reel
NCP431AVLPG	AVLP	1%		TO-92 (TO-226) (Pb-Free)	2000 Units / Bag
NCP431BVSNT1G	VRL	0.5%		SOT-23-3 (Pb-Free)	3000 / Tape & Reel
NCP432BVSNT1G	VRP	0.5%		SOT-23-3 (Pb-Free)	3000 / Tape & Reel

[†]For information on tape and reel specifications, including part orientation and tape sizes, please refer to our Tape and Reel Packaging Specifications Brochure, BRD8011/D.

*SC Prefix for Automotive and Other Applications Requiring Unique Site and Control Change Requirements; AEC-Q100 Qualified and PPAP Capable.

NCP431A, SC431A, NCP431B, NCP432B Series

PACKAGE DIMENSIONS

TO-92 (TO-226)
CASE 29-11
ISSUE AN

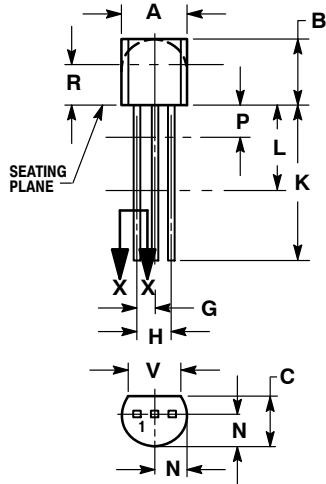

STRAIGHT LEAD

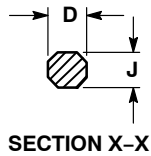

SECTION X-X

NOTES:

1. DIMENSIONING AND TOLERANCING PER ANSI Y14.5M, 1982.
2. CONTROLLING DIMENSION: INCH.
3. CONTOUR OF PACKAGE BEYOND DIMENSION R IS UNCONTROLLED.
4. LEAD DIMENSION IS UNCONTROLLED IN P AND BEYOND DIMENSION K MINIMUM.

DIM	INCHES		MILLIMETERS	
	MIN	MAX	MIN	MAX
A	0.175	0.205	4.45	5.20
B	0.170	0.210	4.32	5.33
C	0.125	0.165	3.18	4.19
D	0.016	0.021	0.407	0.533
G	0.045	0.055	1.15	1.39
H	0.095	0.105	2.42	2.66
J	0.015	0.020	0.39	0.50
K	0.500	---	12.70	---
L	0.250	---	6.35	---
N	0.080	0.105	2.04	2.66
P	---	0.100	---	2.54
R	0.115	---	2.93	---
V	0.135	---	3.43	---

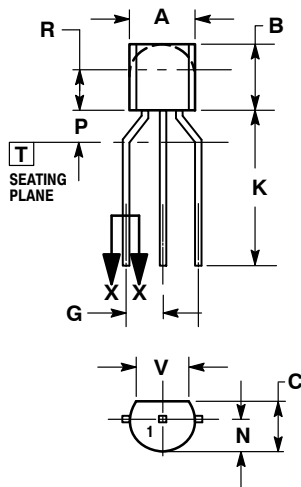

BENT LEAD

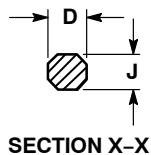

SECTION X-X

NOTES:

1. DIMENSIONING AND TOLERANCING PER ASME Y14.5M, 1994.
2. CONTROLLING DIMENSION: MILLIMETERS.
3. CONTOUR OF PACKAGE BEYOND DIMENSION R IS UNCONTROLLED.
4. LEAD DIMENSION IS UNCONTROLLED IN P AND BEYOND DIMENSION K MINIMUM.

DIM	MILLIMETERS	
	MIN	MAX
A	4.45	5.20
B	4.32	5.33
C	3.18	4.19
D	0.40	0.54
G	2.40	2.80
J	0.39	0.50
K	12.70	---
N	2.04	2.66
P	1.50	4.00
R	2.93	---
V	3.43	---

NCP431A, SC431A, NCP431B, NCP432B Series

PACKAGE DIMENSIONS

SOIC-8 NB
CASE 751-07
ISSUE AK

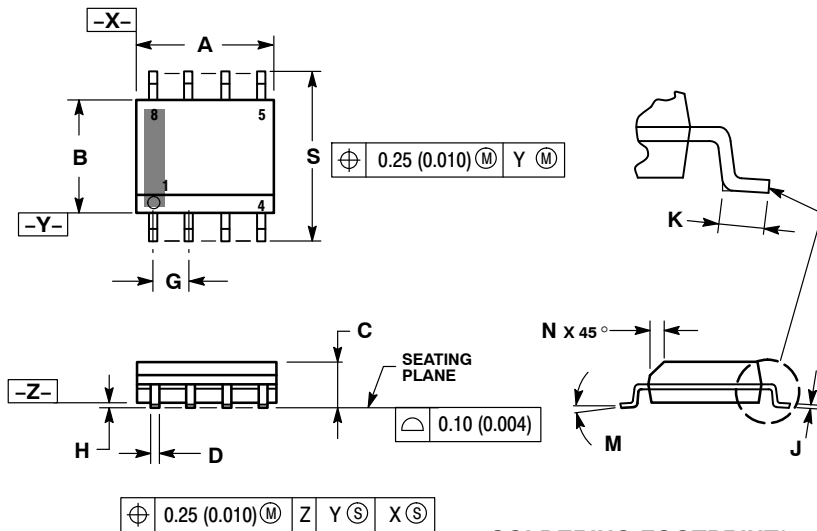

NOTES:

1. DIMENSIONING AND TOLERANCING PER ANSI Y14.5M, 1982.
2. CONTROLLING DIMENSION: MILLIMETER.
3. DIMENSION A AND B DO NOT INCLUDE MOLD PROTRUSION.
4. MAXIMUM MOLD PROTRUSION 0.15 (0.006) PER SIDE.
5. DIMENSION D DOES NOT INCLUDE DAMBAR PROTRUSION. ALLOWABLE DAMBAR PROTRUSION SHALL BE 0.127 (0.005) TOTAL IN EXCESS OF THE D DIMENSION AT MAXIMUM MATERIAL CONDITION.
6. 751-01 THRU 751-06 ARE OBSOLETE. NEW STANDARD IS 751-07.

DIM	MILLIMETERS		INCHES	
	MIN	MAX	MIN	MAX
A	4.80	5.00	0.189	0.197
B	3.80	4.00	0.150	0.157
C	1.35	1.75	0.053	0.069
D	0.33	0.51	0.013	0.020
G	1.27 BSC		0.050 BSC	
H	0.10	0.25	0.004	0.010
J	0.19	0.25	0.007	0.010
K	0.40	1.27	0.016	0.050
M	0°	8°	0°	8°
N	0.25	0.50	0.010	0.020
S	5.80	6.20	0.228	0.244

SOLDERING FOOTPRINT*

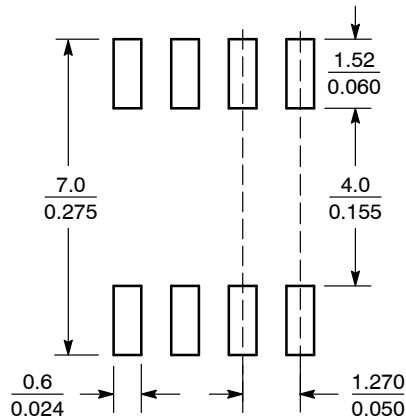

SCALE 6:1 $\left(\frac{\text{mm}}{\text{inches}}\right)$

*For additional information on our Pb-Free strategy and soldering details, please download the ON Semiconductor Soldering and Mounting Techniques Reference Manual, SOLDERRM/D.

NCP431A, SC431A, NCP431B, NCP432B Series

PACKAGE DIMENSIONS

SOT-23 (TO-236)
CASE 318-08
ISSUE AP

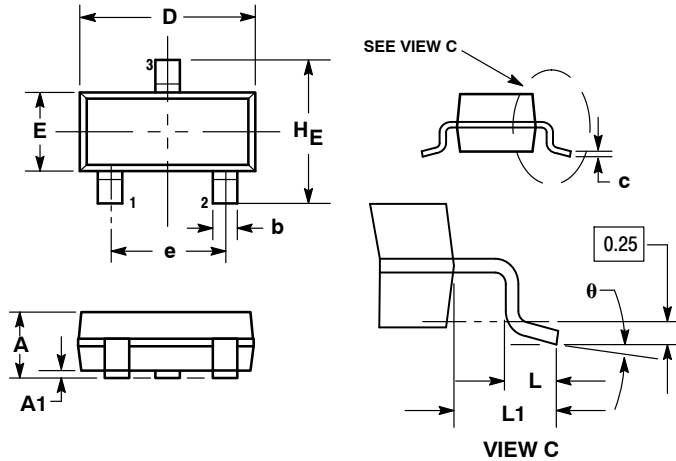

NOTES:

1. DIMENSIONING AND TOLERANCING PER ANSI Y14.5M, 1982.
2. CONTROLLING DIMENSION: INCH.
3. MAXIMUM LEAD THICKNESS INCLUDES LEAD FINISH THICKNESS. MINIMUM LEAD THICKNESS IS THE MINIMUM THICKNESS OF BASE MATERIAL.
4. DIMENSIONS D AND E DO NOT INCLUDE MOLD FLASH, PROTRUSIONS, OR GATE BURRS.

DIM	MILLIMETERS			INCHES		
	MIN	NOM	MAX	MIN	NOM	MAX
A	0.89	1.00	1.11	0.035	0.040	0.044
A1	0.01	0.06	0.10	0.001	0.002	0.004
b	0.37	0.44	0.50	0.015	0.018	0.020
c	0.09	0.13	0.18	0.003	0.005	0.007
D	2.80	2.90	3.04	0.110	0.114	0.120
E	1.20	1.30	1.40	0.047	0.051	0.055
e	1.78	1.90	2.04	0.070	0.075	0.081
L	0.10	0.20	0.30	0.004	0.008	0.012
L1	0.35	0.54	0.69	0.014	0.021	0.029
HE	2.10	2.40	2.64	0.083	0.094	0.104
θ	0°	---	10°	0°	---	10°

SOLDERING FOOTPRINT*

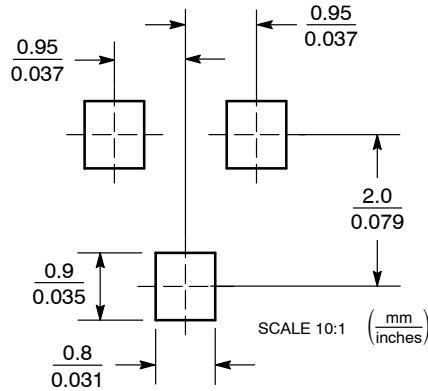

*For additional information on our Pb-Free strategy and soldering details, please download the ON Semiconductor Soldering and Mounting Techniques Reference Manual, SOLDERRM/D.

ON Semiconductor and are registered trademarks of Semiconductor Components Industries, LLC (SCILLC). SCILLC owns the rights to a number of patents, trademarks, copyrights, trade secrets, and other intellectual property. A listing of SCILLC's product/patent coverage may be accessed at www.onsemi.com/site/pdf/Patent-Marking.pdf. SCILLC reserves the right to make changes without further notice to any products herein. SCILLC makes no warranty, representation or guarantee regarding the suitability of its products for any particular purpose, nor does SCILLC assume any liability arising out of the application or use of any product or circuit, and specifically disclaims any and all liability, including without limitation special, consequential or incidental damages. "Typical" parameters which may be provided in SCILLC data sheets and/or specifications can and do vary in different applications and actual performance may vary over time. All operating parameters, including "Typicals" must be validated for each customer application by customer's technical experts. SCILLC does not convey any license under its patent rights nor the rights of others. SCILLC products are not designed, intended, or authorized for use as components in systems intended for surgical implant into the body, or other applications intended to support or sustain life, or for any other application in which the failure of the SCILLC product could create a situation where personal injury or death may occur. Should Buyer purchase or use SCILLC products for any such unintended or unauthorized application, Buyer shall indemnify and hold SCILLC and its officers, employees, subsidiaries, affiliates, and distributors harmless against all claims, costs, damages, and expenses, and reasonable attorney fees arising out of, directly or indirectly, any claim of personal injury or death associated with such unintended or unauthorized use, even if such claim alleges that SCILLC was negligent regarding the design or manufacture of the part. SCILLC is an Equal Opportunity/Affirmative Action Employer. This literature is subject to all applicable copyright laws and is not for resale in any manner.

PUBLICATION ORDERING INFORMATION

LITERATURE FULFILLMENT:

Literature Distribution Center for ON Semiconductor
P.O. Box 5163, Denver, Colorado 80217 USA
Phone: 303-675-2175 or 800-344-3860 Toll Free USA/Canada
Fax: 303-675-2176 or 800-344-3867 Toll Free USA/Canada
Email: orderlit@onsemi.com

N. American Technical Support: 800-282-9855 Toll Free
USA/Canada
Europe, Middle East and Africa Technical Support:
Phone: 421 33 790 2910
Japan Customer Focus Center
Phone: 81-3-5817-1050

ON Semiconductor Website: www.onsemi.com

Order Literature: <http://www.onsemi.com/orderlit>

For additional information, please contact your local Sales Representative



Компания «ЭлектроПласт» предлагает заключение долгосрочных отношений при поставках импортных электронных компонентов на взаимовыгодных условиях!

Наши преимущества:

- Оперативные поставки широкого спектра электронных компонентов отечественного и импортного производства напрямую от производителей и с крупнейших мировых складов;
- Поставка более 17-ти миллионов наименований электронных компонентов;
- Поставка сложных, дефицитных, либо снятых с производства позиций;
- Оперативные сроки поставки под заказ (от 5 рабочих дней);
- Экспресс доставка в любую точку России;
- Техническая поддержка проекта, помощь в подборе аналогов, поставка прототипов;
- Система менеджмента качества сертифицирована по Международному стандарту ISO 9001;
- Лицензия ФСБ на осуществление работ с использованием сведений, составляющих государственную тайну;
- Поставка специализированных компонентов (Xilinx, Altera, Analog Devices, Intersil, Interpoint, Microsemi, Aeroflex, Peregrine, Syfer, Eurofarad, Texas Instrument, Miteq, Cobham, E2V, MA-COM, Hittite, Mini-Circuits, General Dynamics и др.);

Помимо этого, одним из направлений компании «ЭлектроПласт» является направление «Источники питания». Мы предлагаем Вам помощь Конструкторского отдела:

- Подбор оптимального решения, техническое обоснование при выборе компонента;
- Подбор аналогов;
- Консультации по применению компонента;
- Поставка образцов и прототипов;
- Техническая поддержка проекта;
- Защита от снятия компонента с производства.



Как с нами связаться

Телефон: 8 (812) 309 58 32 (многоканальный)

Факс: 8 (812) 320-02-42

Электронная почта: org@eplast1.ru

Адрес: 198099, г. Санкт-Петербург, ул. Калинина, дом 2, корпус 4, литера А.