

# ELECTRONIC PLAYGROUND™ and LEARNING CENTER

MODEL EP-130

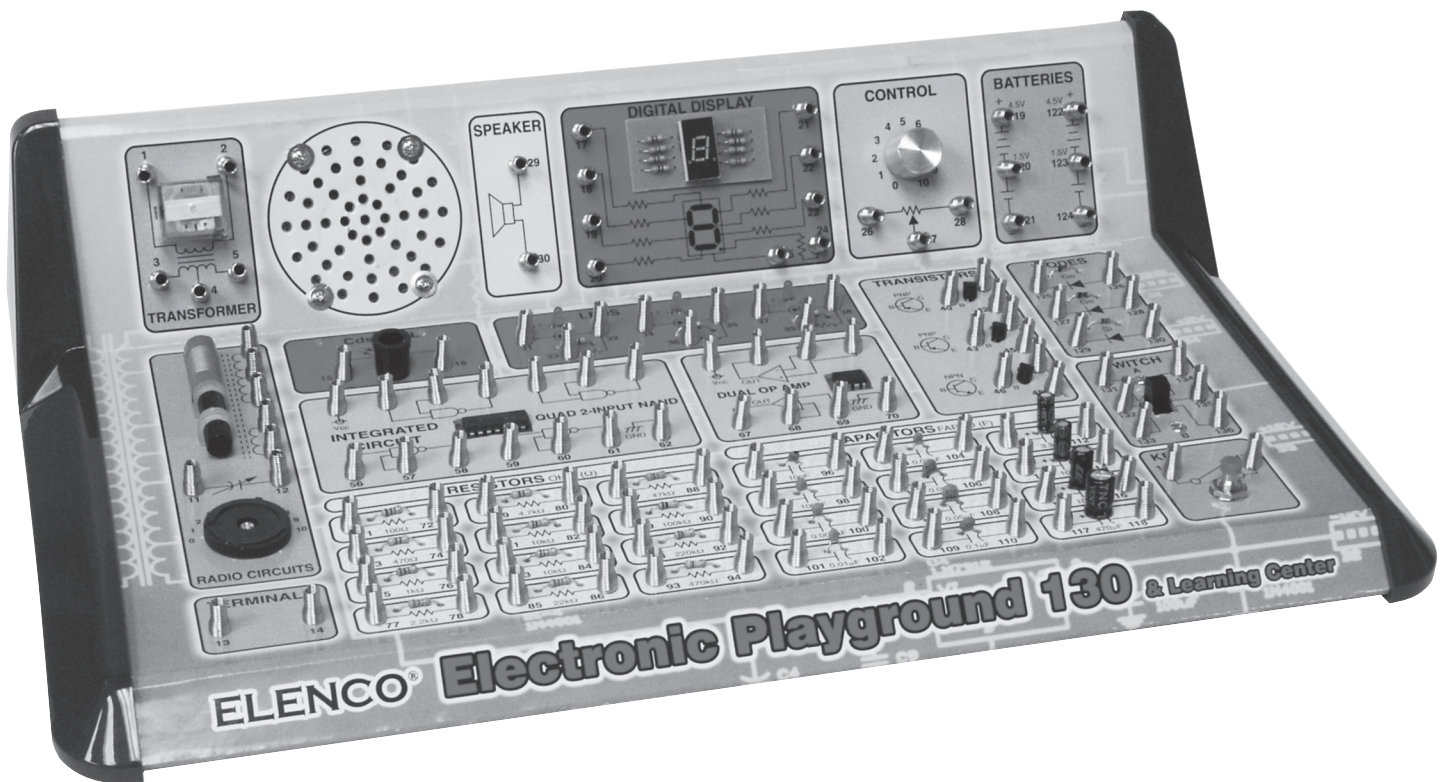

**ELENCO®**  
Wheeling, IL, USA

**Important:** If you encounter any problems with this kit, **DO NOT RETURN TO RETAILER.** Call toll-free (800) 533-2441 or e-mail us at: help@elenco.com. Customer Service • 150 Carpenter Ave. • Wheeling, IL 60090 U.S.A.

**WARNING:** Always check your wiring before turning on a circuit. Never leave a circuit unattended while the batteries are installed. Never connect additional batteries or any other power sources to your circuits.



**WARNING:**  
**CHOKING HAZARD** - Small parts.  
Not for children under 3 years.

Conforms to all applicable U.S. government requirements.

## Batteries:

- Do not short circuit the battery terminals.
- Never throw batteries in a fire or attempt to open its outer casing.
- Use only 1.5V "AA" type, alkaline batteries (not included).
- Insert batteries with correct polarity.
- Do not mix alkaline, standard (carbon-zinc), or rechargeable (nickel-cadmium) batteries.
- Non-rechargeable batteries should not be recharged. Rechargeable batteries should only be charged under adult supervision, and should not be recharged while in the product.
- Do not mix old and new batteries.
- Remove batteries when they are used up.
- Batteries are harmful if swallowed, so keep away from small children.

## TABLE OF CONTENTS

<b>Before We Begin</b>	Page 4	<b>III. LED DISPLAY CIRCUITS</b>	36
<b>Installing the Batteries</b>	4	23. LED Display Basics	37
<b>Making Wire Connections</b>	5	24. Digital Display Circuit for the Seven-Segment LED	38
<b>Components</b>	5	25. LED Display with CdS and Transistor	39
<b>Building Your First Project</b>	9	26. Switching the LED Display Using Transistor Control	40
<b>Troubleshooting</b>	10	<b>IV. WELCOME TO DIGITAL CIRCUITS</b>	41
<b>Helpful Suggestions</b>	10	27. "Flip-Flop" Transistor Circuit	42
<b>I. PLAYGROUND OF ELECTRONIC CIRCUITS</b>	11	28. "Toggle Flip-Flop" Transistor	43
1. Woodpecker	12	29. "AND" Diode Transistor Logic with LED Display	44
2. Police Siren	13	30. "OR" DTL Circuit with Display	45
3. Metronome	14	31. "NAND" DTL Circuit with Display	46
4. Grandfather Clock	15	32. "NOR" Transistor Circuit with Display	47
5. Harp	16	33. "Exclusive OR" DTL Circuit	48
6. Tweeting Bird	17	<b>V. MORE FUN WITH DIGITAL CIRCUITS</b>	49
7. Meowing Cat	18	34. "BUFFER" GATE using TTL	50
8. Calling' Fish	19	35. "INVERTER" GATE using TTL	51
9. Strobe Light	20	36. "AND" GATE using TTL	52
10. Sound Effects for Horror Movies	21	37. "OR" GATE using TTL	53
11. Machine Gun Oscillator	22	38. "R-S Flip-Flop" using TTL	54
12. Motorcycle Mania	23	39. "Triple-Input AND" Gate using TTL	55
13. Vision Test	24	40. "AND" Enable Circuit using TTL	56
14. Patrol Car Siren	25	41. "NAND" Enable Circuit using TTL	57
<b>II. BASIC ELECTRONICS CIRCUITS</b>	26	42. "NOR" Enable Circuit using TTL	58
<b>A MAJOR CHANGE</b>	27	43. "NAND" Gate Making a Toggle Flip-Flop	59
15. Dimming the Light	28	44. "Exclusive OR" GATE using TTL	60
16. Flip Flopping	29	45. "OR" Enable Circuit using TTL	61
17. Capacitor Discharge Flash	30	46. Line Selector using TTL	62
18. Transistor Action	31	47. Data Selector using TTL	63
19. Series and Parallel Capacitors	32		
20. Transistor Switching	33		
21. Series and Parallel Resistors	34		
22. Amplify the Sound	35		

<b>VI. MEET TRANSISTOR-TRANSISTOR LOGIC</b>	64	93. LED Initials	112
48. Blinking LEDs	65	94. Wake Up Siren	113
49. Machine Sound	66	95. Voice Activated LED	114
50. Astable Multivibrator Using TTL	67	96. Logic Tester	115
51. Tone Generator	68		
52. Monster Mouth	69	<b>IX. MORE FUN WITH OPERATIONAL AMPLIFIERS</b>	116
53. Dark Shooting	70	97. Voice Power Meter	117
54. A One-Shot TTL	71	98. Reset Circuit	118
55. Transistor Timer Using TTL	72	99. RC Delay Timer	119
56. LED Buzzing	73	100. Listen To Alternating Current	120
57. Another LED Buzzing	74	101. Pulse Frequency Multiplier	121
58. Set/Reset Buzzer	75	102. White Noise Maker	122
59. Another Set/Reset Buzzer	76	103. Light-Controlled Sound	123
		104. DC-DC Converter	124
<b>VII. OSCILLATOR APPLICATION CIRCUITS</b>	77	105. Super Sound Alarm	125
60. Ode to the Pencil Lead Organ	78	106. Op Amp Three-Input "AND" Gate	126
61. Double-Transistor Oscillator	79	107. Timer	127
62. Decimal Point Strobe Light	80	108. Cooking Timer	128
63. "The Early Bird Gets the Worm"	81		
64. Adjustable R-C Oscillator	82	<b>X. RADIO AND COMMUNICATION CIRCUITS</b>	129
65. Heat-Sensitive Oscillator	83	109. Operational Amplifier AM Radio	130
66. Pulse Alarm	84	110. AM Code Transmitter	131
67. Pushing & Pulling Oscillator	85	111. AM Radio Station	132
68. Slow Shut-off Oscillator	86	112. Crystal Set Radio	133
69. Electronic Organ Detector	87	113. Two-Transistor Radio	134
		114. Morse Code Oscillator With Tone Control	135
<b>VIII. MEET THE OPERATIONAL AMPLIFIER</b>	88		
70. Operational Amplifier Comparator	89	<b>XI. TEST AND MEASUREMENT CIRCUITS</b>	136
71. Changing Input Voltage	90	115. Water Level Warning	137
72. Non-inverting Dual Supply Op Amp	91	116. Water Level Alarm	138
73. Inverting Dual Supply Op Amp	92	117. Audio Signal Hunter	139
74. Non-inverting Amplifier	93	118. RF Signal Tracer	140
75. Dual-Supply Differential Amplifier	94	119. Square Wave Oscillator	141
76. Miller Integrating Circuit	95	120. Sawtooth Oscillator	142
77. Stable-Current Source	96	121. Audio Continuity Tester	143
78. Operational Amplifier Blinking LED	97	122. Audio Rain Detector	144
79. LED Flasher	98	123. Audio Metal Detector	145
80. Double LED Blinker	99	124. Water Level Buzzer	146
81. Single Flash Light	100	125. Pure Tone Generator	147
82. Introducing the Schmitt Trigger	101	126. Resistance Tester	148
83. Initials on LED Display	102	127. Transistor Tester	149
84. Logic Testing Circuit	103	128. Sine Wave Oscillator	150
85. Voice-Controlled LED	104	129. Sine Wave Oscillator With Low Distortion	151
86. Buzzing' with the Op Amp	105	130. Twin-T Oscillator	152
87. Sweep Oscillator	106	<b>INDEX</b>	153
88. Falling Bomb	107	<b>PARTS LIST</b>	155
89. Alert Siren	108	<b>DEFINITION OF TERMS</b>	156
90. Crisis Siren	109	<b>IDENTIFYING RESISTOR VALUES</b>	159
91. Op Amp Metronome	110	<b>IDENTIFYING CAPACITOR VALUES</b>	159
92. Burglar Buzzer	111	<b>METRIC UNITS AND CONVERSIONS</b>	159

---

## BEFORE YOU START THE FUN!

Welcome to the thrilling world of electronics! Now that you have your Elenco® EP-130 Electronic Playground Kit, you can learn about electronics while doing 130 fun experiments. In this kit we have included everything you will need to start off on this electronics adventure, well except the batteries that is 😊.

As you go through this manual and do the experiments, you will notice that we have arranged the experiments, as well as information, into a logical progression. We will start off with easy circuits and then work toward the more intricate ones. Take your time and be sure to have some fun!

Each electronic component in the kit is connected to springs, so you can do all the circuit assembly without having to solder. To build a working project, all you have to do is connect the wires to the terminals as shown in each wiring sequence. There is no danger when doing these projects because you are using low voltage batteries, not the standard AC voltages.

Our simple instructions will show you how to operate the circuit for each experiment. A *schematic* diagram is also included, to help you learn how the circuit works. A *schematic* is simply a blueprint that shows how different parts are wired together. An image or symbols for each of the components in your kit are printed next to each piece.

As you will notice we refer to a *Volt / Ohm Meter* (VOM) for making measurements. A VOM or multimeter is a instrument that measures voltage, current (amperes or amps), and resistance (ohms- $\Omega$ ). You will learn more about these in the upcoming pages. If you really want to learn about electronic circuits, it is vital that you learn how to measure circuit values - for only then will you really understand electronic circuitry.

You do not have to have or use a VOM to do the experiments but you will find that it helps to better grasp how the circuits work. The VOM is a good investment if you plan to stay interested in electricity and electronics.

---

## INSTALLATION OF BATTERIES

This kit requires six (6) “AA” batteries. To install the batteries to the back of your kit make sure to install them in the corresponding compartments. Put the + end and the – end correctly into the kit, the + end for the battery is the side that has the metal cap.

**Remember:** Never leave a dying battery or dead battery in your kit. Even if they are “leak-proof”, they still have the potential to leak damaging chemicals.

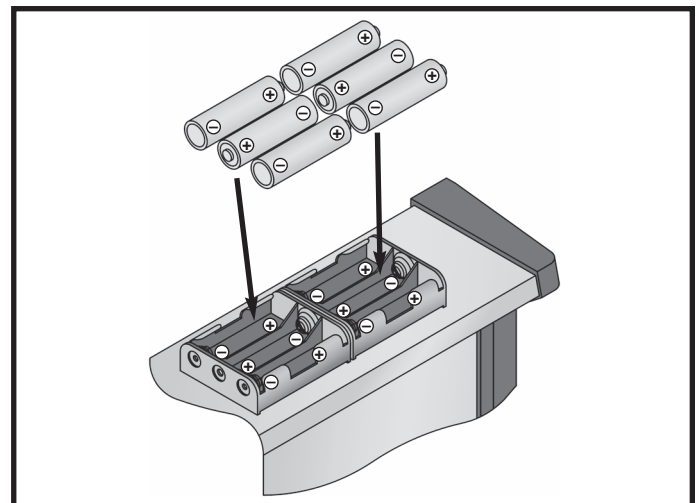

## WIRING CONNECTIONS

Provided in your kit are spring terminals and pre-cut wires, make the wires snap together for your use in the numerous projects. To join a wire to a spring terminal, just directly bend the spring over to one side and then install the wire into the opening.

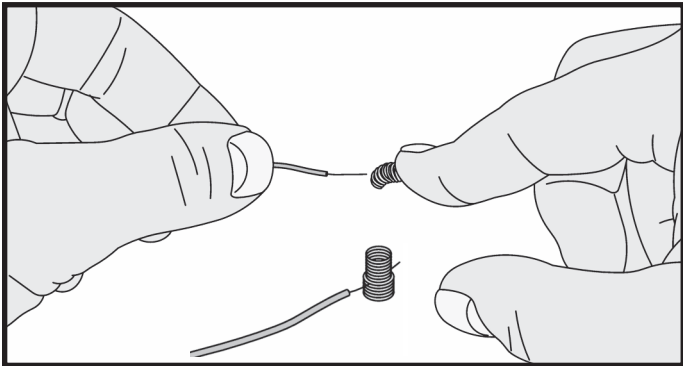

When you have to join two or three wires into a single spring terminal, be sure that the first wire does not come loose when you attach the second and third wires. The simplest way to do this is to place the spring onto the opposing side where you have connected the first wire.

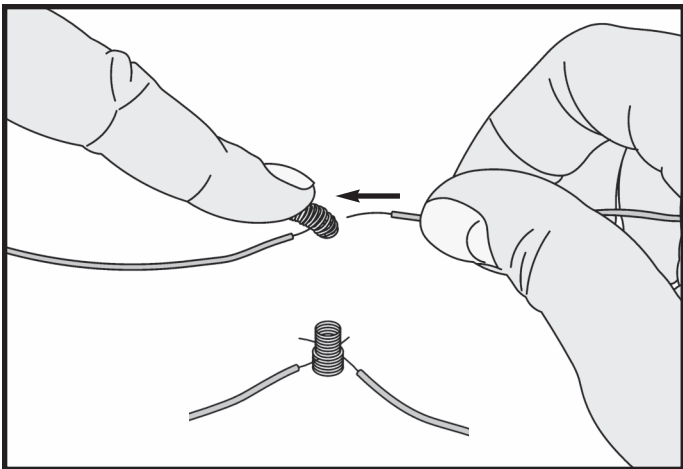

Only insert the exposed or shiny part of the wire into the spring terminal. The electrical connection will not be made if the plastic part of the wire is inserted into the terminal. Removing the wire from the spring terminals is simply just bending each terminal and then pulling the wires out of it.

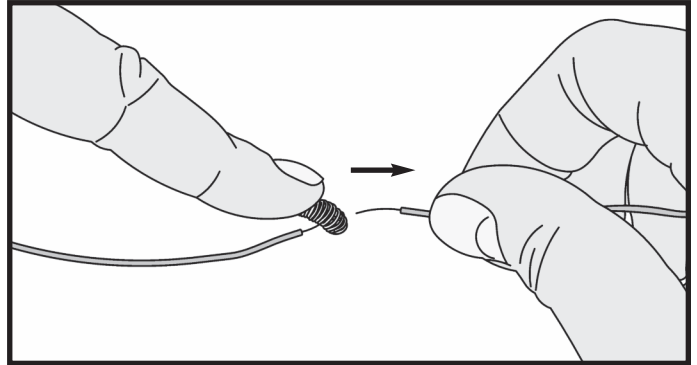

If the exposed metal ends of some of the wires break off due to great use, you should just simply remove 3/8" of the insulation from the wire of the broken end and then simply twist the strands together. To remove the installation you can use either a wire-stripper tool or a simple penknife. Be extremely careful when doing this because penknives are remarkably sharp.

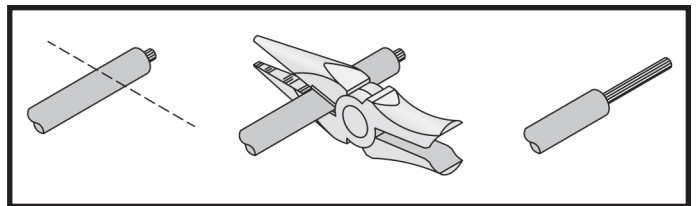

## COMPONENTS

This kit has more than 30 distinct components. If this happens to be your first time with electronics don't fret over not knowing the difference between a resistor or a transistor, because the general purpose of each component will be described. The following explanations will help you comprehend what each component does and you will also gain more knowledge of each component as you do each experiment. There is also a parts list in the back of this manual, that way you can compare the parts in your kit with those recorded in the back.

**Resistors:** Why is the water pipe that goes to the kitchen faucet in your house smaller than the one from the water company? And why is the pipe smaller than the main water line that disburses the water to your entire town? Because you don't need a lot of water. The pipe size controls the water flow to what you really need. Electricity works in the same manner, except that the wires have a minimal resistance that they would have to be particularly thin to limit the electricity flow. They would be solid enough to handle and break effortlessly. However, the flow of water through a large pipe could be restricted to by filling a part of the pipe with rocks (a

fine screen would keep rocks from falling over), which would prolong the flow of water but not stop it completely. Like rocks are for water, resistors work in a similar way. They regulate how much electric current flows. The resistance, is expressed in ohms ( $\Omega$ , named in honor of George Ohm), kilohms ( $k\Omega$ , 1,000 ohms) or megohms ( $M\Omega$ , 1,000,000 ohms) is a determination of how much resistor resists the flow of electricity. The water through a pipe can be increased by an increase in water pressure or the removal of rocks. In a similar way you can increase the electric current in a circuit by increasing the voltage or by the use of a lower value resistor (this will be shown in a moment). Below the symbol for the resistor is shown.

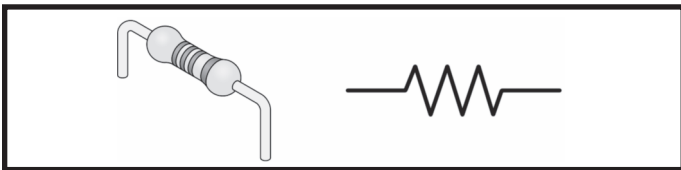

**Resistor Color Code:** The method for marking the value of resistance on a part is by using colored bands on each resistor. The representation of the first ring is the digit of the value of the resistor. The second ring is a representation of the second digit of the resistors value. The third ring means that you to which power of ten to multiply by, ( or the amount of zeros to add). The fourth and final ring is a representation of the construction tolerance. A majority of resistors have a gold band that represents 5% tolerance. Simply this means that the resistor value is guaranteed to be 5% of the valued marked. See the color chart on page 159.

**Variable Resistor (Control):** The variable resistor is simply a control and this is required in many electric circuits. The variable resistor can be used as a light dimmer, volume control, and in many other circuits when you are wanting to change resistance easily and quickly. A normal resistor is shown, this contains an additional arm contact that moves along the resistive material and can tap off the resistance desired.

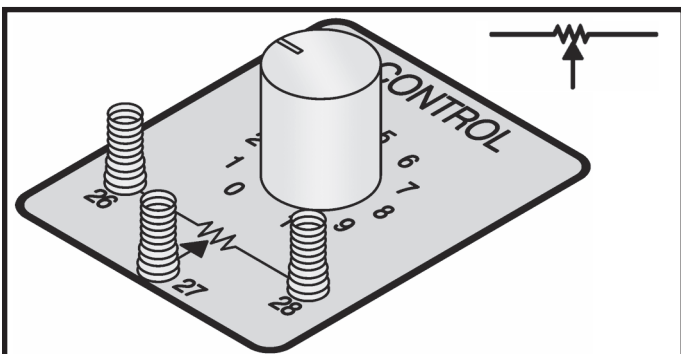

**Capacitors:** Capacitors move alternating current (AC) signals while prohibiting direct current (DC) signals to pass. They store electricity and can function as filters to smooth out signals that pulsate. Capacitors that are small are traditionally used in high-frequency applications such as radios, transmitters, or oscillators. Larger capacitors ordinarily reserve electricity or act as filters. The *capacitance* (capacity for storing electricity) of a capacitor is expressed in a unit known as *farad*. An extremely large amount of electricity defines the farad. Most of the value of capacitors is predetermined in millionths-of-a-farad or microfarads.

*Electrolytic* - Electrolytic are the four largest capacitors. They are marked with an “-”. There is only one-way to connect them to the circuit, the + and the - wires must always go into the correct terminals.

**Note** - For safety, the electrolytic capacitors used in the EP-130 are nonpolarized type.

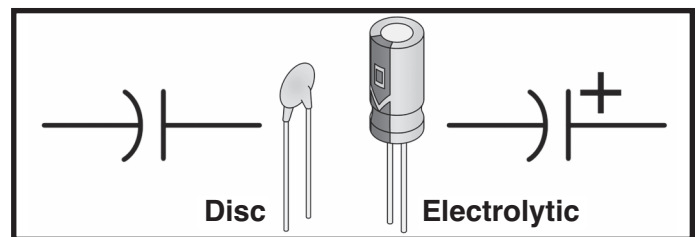

*Disc* - Unlike the electrolytic above, these capacitors have no polarity and can be connected in either way.

**Tuning Capacitor:** Ever wonder what that knob that changes the stations on your radio is? It's a tuning capacitor. When the knob is rotated, the capacitance is changed. This alters the frequency of the circuit, letting through only one frequency and blocking out the rest.

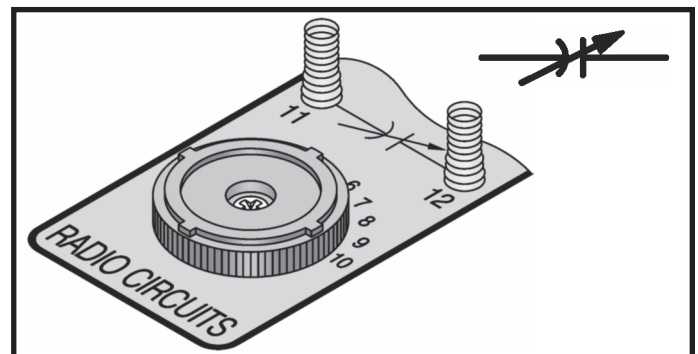

**Diodes:** Are like one-way streets. They allow the current to flow in only one direction. There are three of these in your kit. Your kit contains one silicon diode (marked Si) as well as two germanium diodes (marked Ge).

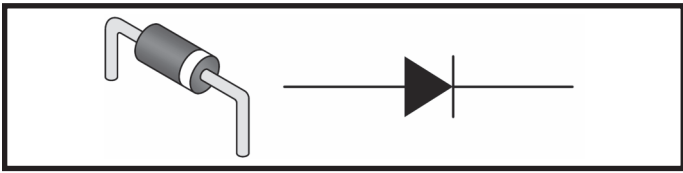

**Transistors:** Three transistors can be found in your kit. The part that makes each transistor work is a tiny chip, which is made of either germanium or silicon. There are a total of three connections points on each transistor. They are B, which stands for base, C, which stands for collector, and E, which stands for emitter. Mainly transistors are used to amplify weak signals. Transistors can also be used as switches to connect or disconnect other components as well as oscillators to permit signals to flow in pulses.

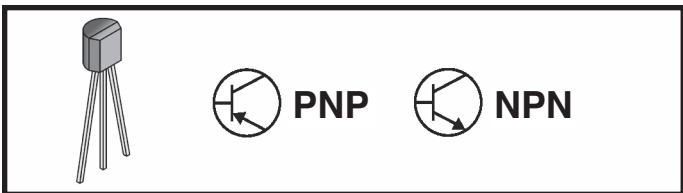

**LEDs (Light Emitting Diodes):** These are special diodes because they give off light whenever electricity passes through them. (The current can only pass through in one direction—similar to “regular” diodes).

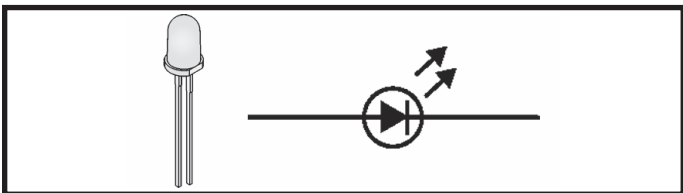

**LED Digital Display:** Seven Light Emitting Diodes are arranged to create an outline that can show most letters of the English alphabet and all the numbers. An additional LED is added to represent a decimal point.

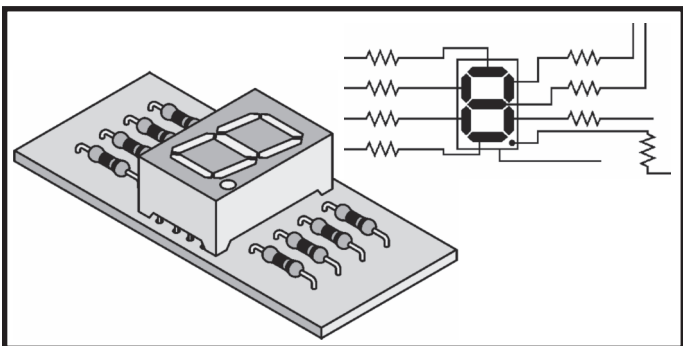

The “8” LED display is mounted on a board and to prevent burning out the display with excess current, permanent resistors have been wired in.

**Integrated Circuit:** The transistor was invented in the 1940’s and after that the next big break through in electronics was in the 1960’s with the invention integrated circuit or the ICs. The advantage of this that the equivalent of hundreds or even thousands of transistors, diodes and even resistors can be placed into one small package.

Two types of ICs are used in this kit. They are the quad two-input NAND and the dual-operational amplifier, and you will have the chance to learn more about these in a bit.

Simple ICs will help you to understand enough to grasp the basic theories of more advanced ICs.

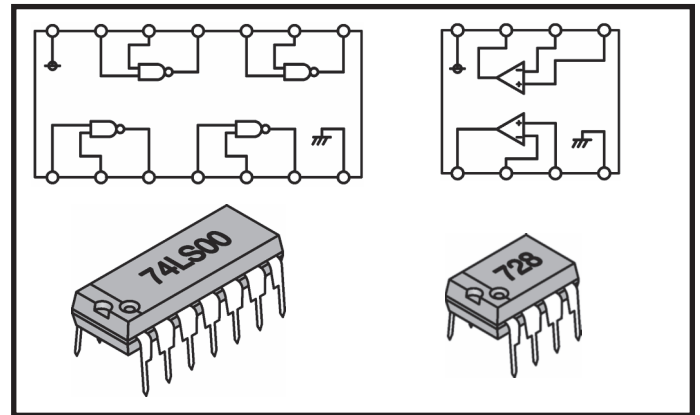

**Cadmium Sulfide (CdS) Cell:** This is what is known as a semiconductor, which practically resists electricity while it conducts. The resistance changes by the amount of light that is shined upon it.

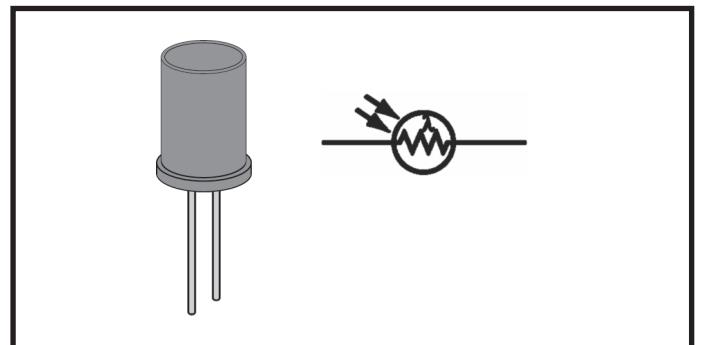

**Antenna:** This cylindrical component with a coil of fine wire wrapped around it is a radio antenna. If you're wondering what the dark colored rod is, it's actually mostly powdered iron. It's also known as a "Ferrite Core", which is efficient for antennas, and used in almost all transistor radios.

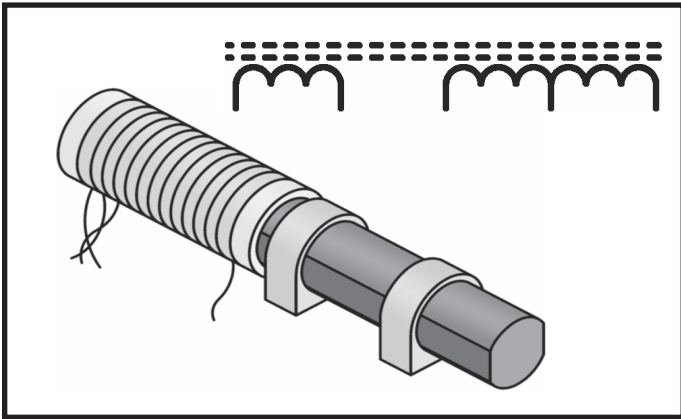

**Transformer:** Did you know that if you were to wrap two wires from different circuits around different ends of an iron bar, and if you were to add current in the first circuit, it will magnetically create current in the second circuit? That's exactly what a transformer is! Transformers are used to isolate parts of a circuit, to keep them from interfering with each other. If the iron bar in a transformer were allowed to rotate, it would become a motor. However, if a magnet within a coil is rotating then an electrical current is made; this is called a generator. Those two ideas may not seem important but they are the foundation of the present society. Pretty much all of the

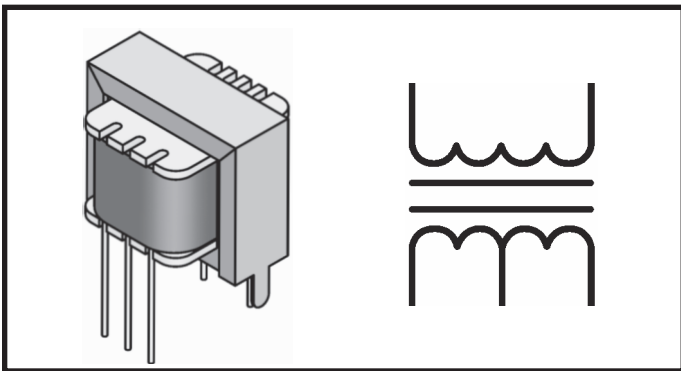

electricity used in this world is generated by huge generators, which are propelled by water pressure or steam. Wires transport energy to homes and businesses where it will be used. Motors are used to convert the electricity back into mechanical form so that it can be used to drive machinery and appliances.

**Speaker:** Did you know that electrical energy is converted into sound through a speaker? By using the

energy from an AC electrical signal it creates mechanical vibration. Sound waves, which are created by variations of vibrations and then travel across the room. When you hear a sound it is actually your ears feeling the pressure from the air vibrations. To operate a speaker a high current and a low voltage are needed, so the transformer will also be used with the speaker. (A transformer can convert a high-voltage/low current to a low-voltage/high current).

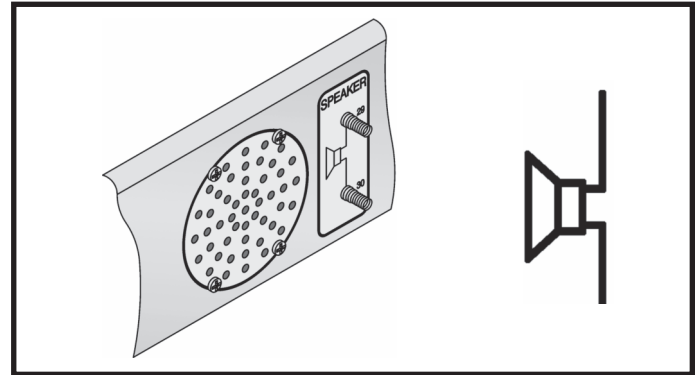

Similar to the speaker, is the earphone. It is movable and more sensitive than the speaker, otherwise they are the same. The earphone you will be using is efficient as well as lightweight and can be used without taking away too much electrical energy from the circuit. Sound wise you will be using the earphone for weak sounds and for louder sounds the speaker will be used.

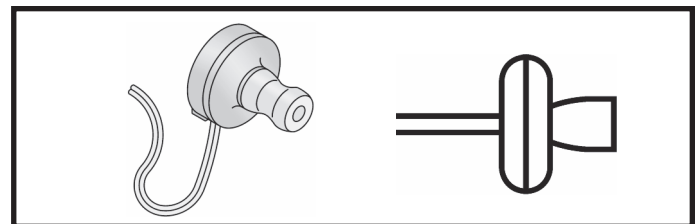

**Batteries:** The battery holders that are used in this kit are constructed to hold six (6) "AA" batteries. These batteries will be the supplier of all the power used in your experiments. When you connect the wires to the batteries make sure that you only connect the batteries to terminals noted. Terminals 119 and 120 provide 3 volts while terminals 119 and 121 provide 4.5 volts. Be aware that parts can be damaged (burned out) if you connect too much voltage (you can get up to 9 volts from the connections to the batteries) Be sure to make battery connections the right way.

**Caution:** Make sure your wiring uses the correct polarity (the "+" and "-" sides of the component)! Some parts can be permanently damaged if you reverse polarity.



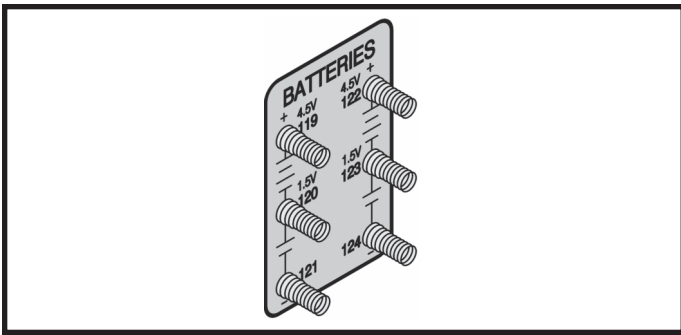

**Switch:** You know what a switch is – you use switches every day. When you slide (or flip) to the proper position, the circuit will be completed, allowing current to flow through. In the other position a break is made, causing the circuit to be “off”. The switch that we will be using is a double-pole, double-throw switch. You will learn about that later on.

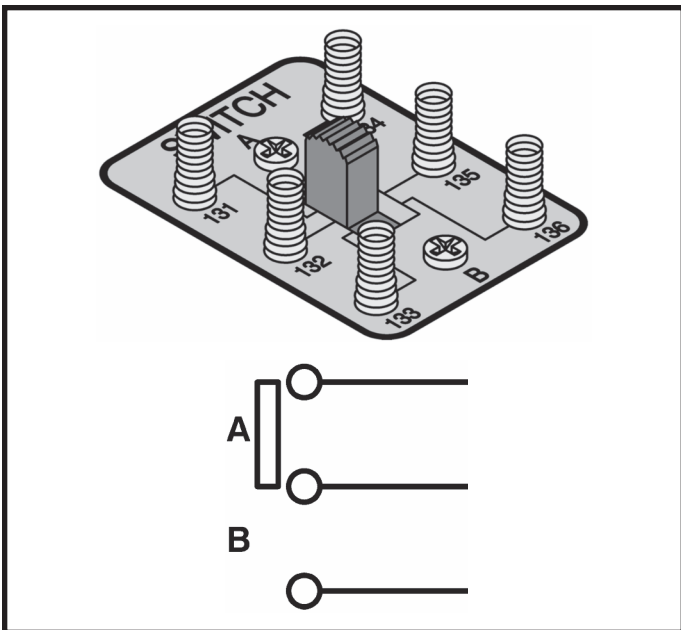

**Key:** The key is a simple switch—you press it and electricity is allowed to flow through the circuit. When you release it, the circuit is not complete because a break is caused in the circuit’s path. The key will be used in most circuits often times in signaling circuits (you can send Morse code this way as well as other things).

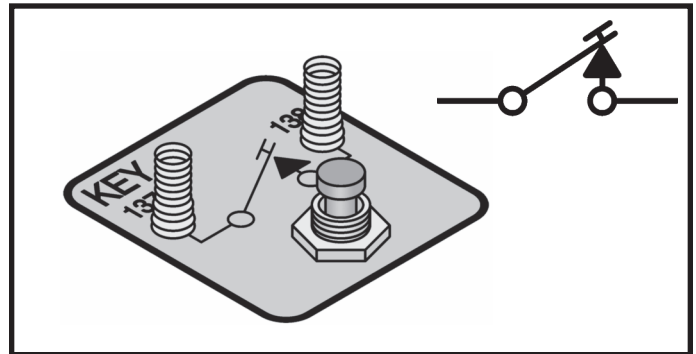

**Terminals:** Two terminals will be used in some projects (terminals 13 and 14). They will be used to make connections to external devices such as an earphone, antenna or earth ground connection, special sensor circuits and so forth.

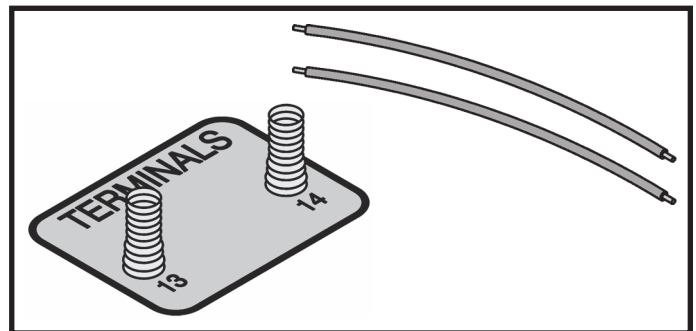

**Wires:** Wires will be used to make connections to the terminals.

Your parts and spring terminals are mounted on the colorful platform. You can see how the wires are connected to the parts and their terminals if you look under the platform.

## YOUR FIRST PROJECT

A simple wiring sequence is listed for each project. Connect the wires with appropriate length between each grouping of terminals listed. When doing the experiment use the shortest wire that possibly gets the job done. New groupings will be separated by a comma, connect the terminals in each group.

As an example, here is the project 1 wiring sequence:

1-29, 2-30, 3-104-106, 4-28-124, 5-41-105, 27-88, 75-87-103-40, 115-42-119, 76-116, 121-22.

Connect a wire between 1 and 29, another wire between 2 and 30, another between 3 and 104 and then another wire between 104 and 106. Continue until all connections are made.

**Caution:** The last connection in each wiring sequence is an important power wire; this is deliberate. It is important that you make this connection your LAST connection. Damage can occur if one part of the circuit is completed before another. Therefore follow the wiring sequence exactly.

---

## TROUBLESHOOTING

You should have no problem with the projects working properly if you follow the wiring instructions. However, if you do encounter a problem you can try and fix it by using the following troubleshooting steps. These steps are comparable to those steps that electronic technicians use to troubleshoot complex electronic equipment.

1. Are the batteries being used new? If they are not, this may be your problem because the batteries could be too weak to power the project.
2. Is the project assembled properly? Check all the wiring connections to make sure that you have all the terminals wired correctly. Sometimes having someone else look at it helps to find the problem.

3. Are you following the schematic diagram and the explanation of the circuit? As your understanding and knowledge expands of electronics, you will be able to troubleshoot by following only a schematic, and once you add the description of the circuit you will be able to figure out your own problems.
4. If you have VOM, try taking some measurements of the voltage and current. You might be surprised just how handy a VOM really is.
5. Try building project 24 (Digital Display Circuit for the Seven-Segment LED). This is a very simple circuit that lights part of the LED display using only 2 wires.

Contact Elenco® if you still need help.

---

## SUGGESTIONS TO HELP

### Keep a Notebook

As you're about to find out, you are going to learn many things about electronics by using this kit. As you learn, many of the things you discover in the easy projects will be built upon in later projects. We suggest using a notebook to help you organize the data you will be collecting.

This notebook does not have to be like the one you use in school. Think of it more as a fun notebook, that way you can look back on the all the projects you have done once you finish.

### Wiring Sequence Marking

When you are wiring a project, especially those with lots of connections, you will find it helpful to mark off each terminal number as you connect the wires to it. Use a pencil and make light marks so that you can go back multiple times and re-read the sequence.

### Collecting Components

You should start to make your own collection of electronic parts and therefore have your own scrap box of electronic parts. You can build your own circuits in or on top of a framework, box or container. You could use your circuit as a Science Fair project at school and even make a major research project from it.

# **I. PLAYGROUND OF ELECTRONIC CIRCUITS**

# EXPERIMENT #1: WOODPECKER

For your first experiment you are going to make a circuit that sounds like a woodpecker chirping. Follow the wiring sequence carefully and observe the drawings. Don't forget to make all the proper connections and have fun!

The simple circuit shown here does not have a key or a switch, but you can easily add one. Replace connection 124-28 with connections 124-137 and 138-28 to connect the key. Or, you can hook the switch up by replacing 124-28 with connections 124-131 and 132-28. Now you can easily turn off and on the circuit. Go outside and see if you can attract birds with it.

Want a different sound? Try varied combinations of capacitance and resistance in place of the 100µF capacitor and the 1kΩ resistor. To change the 100µF capacitor to 470µF, disconnect terminal 116 and transfer to terminal 118. Then, reconnect the wire from 115 to connect to 117. Your "bird" might sound like a cricket, or a bear!

Also, you can try using the 3V power supply. Disconnect terminal 119 and connect it to terminal 123. Now your bird might sound like an English sparrow. Feel free to experiment. Just don't replace the 47kΩ resistor with anything below 10kΩ, because it might damage the transistor.

## Notes:

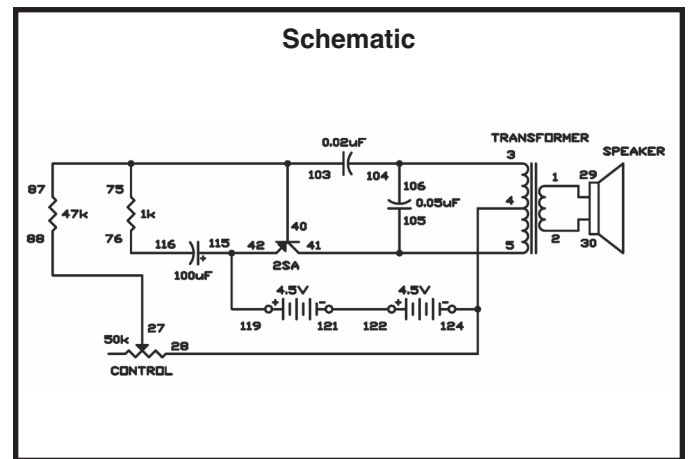

## Wiring Sequence:

- 1-29
- 2-30
- 3-104-106
- 4-28-124
- 5-41-105
- 27-88
- 75-87-103-40
- 115-42-119
- 76-116
- 121-122

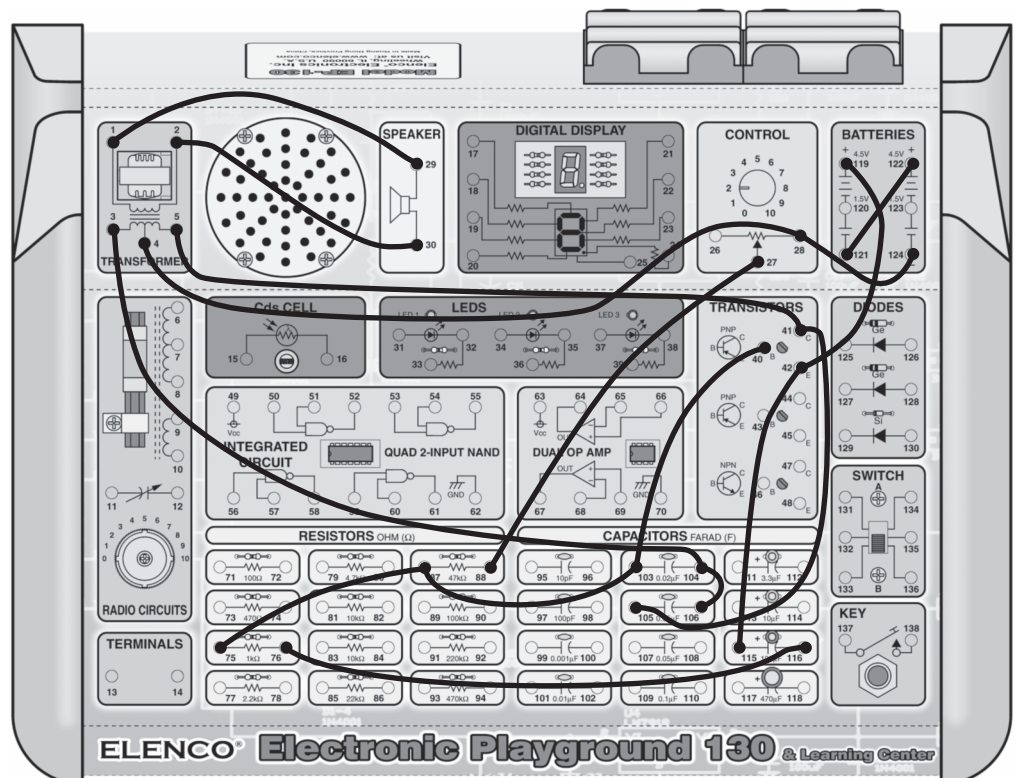

## EXPERIMENT #2: POLICE SIREN

Here is the first siren you are going to do – don't be shocked if this experiment becomes the most famous circuit in this kit.

This siren sounds like a real siren on a police car! After the wiring is completed press the key. The tone you eventually hear gets higher after pressing the key. When you release the key, the tone gets lower and then fades out.

Try some of these modifications:

1. If you change the  $10\mu\text{F}$  capacitor to a  $100\mu\text{F}$  or a  $470\mu\text{F}$  it will give a very long delay for both turn off and turn on.
2. Change the circuit to remove the delays by temporarily disconnecting the  $10\mu\text{F}$  capacitor.
3. Change out the  $0.02\mu\text{F}$  capacitor to a  $0.01\mu\text{F}$  capacitor, and then to a  $0.05\mu\text{F}$  capacitor.

### Notes:

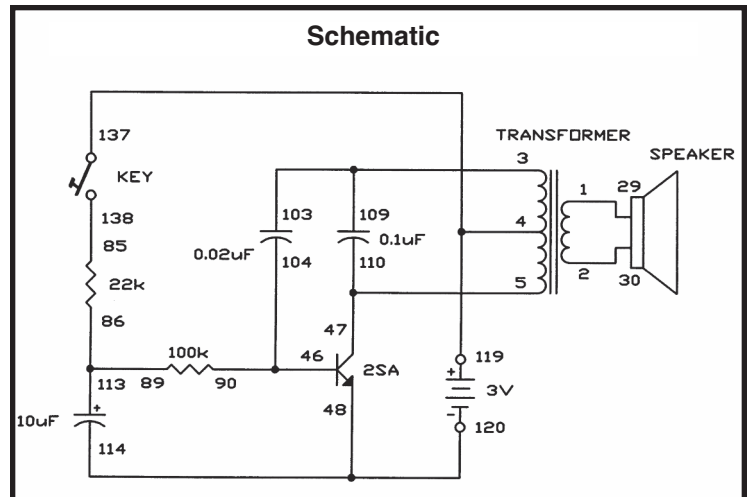

### Wiring Sequence:

- 1-29
- 2-30
- 3-103-109
- 4-119-137
- 5-47-110
- 46-104-90
- 114-48-120
- 85-138
- 86-89-113

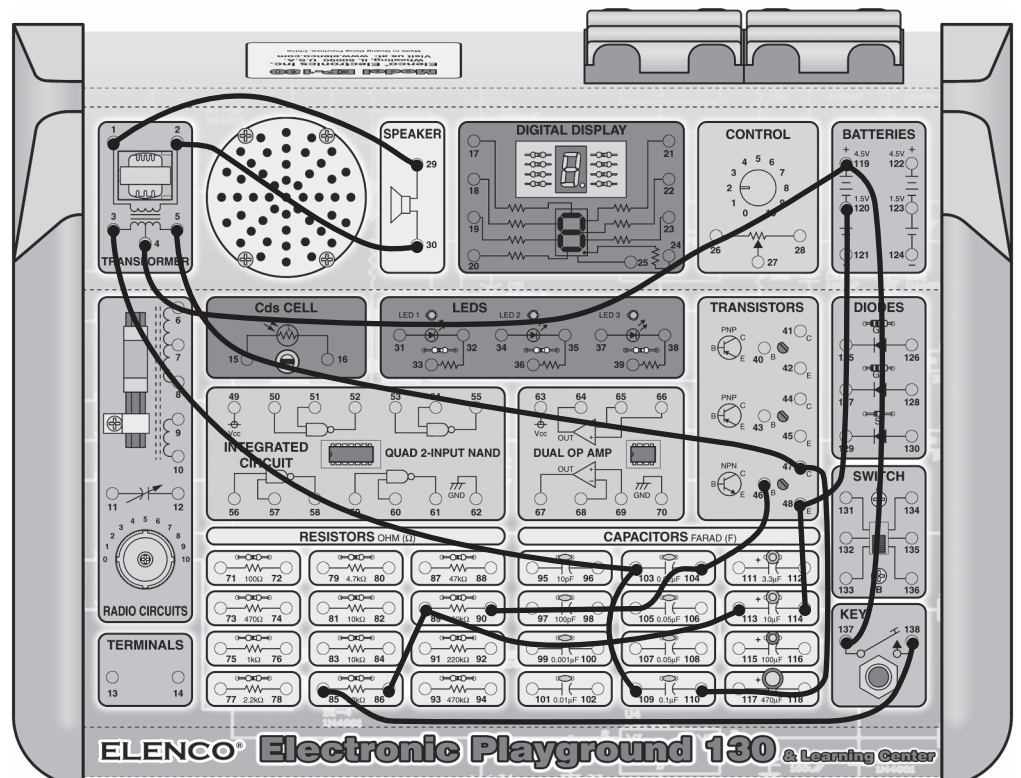

# EXPERIMENT #3: METRONOME

Learning to play a musical instrument? Then you might find this experiment helpful. This is an electronic version of the metronome, used by musical students and musical geniuses alike, worldwide.

If you press the key, you hear a repeating sound from the speaker. Turn the control knob to the right and you'll hear the sound "get faster" as the time between sounds shortens.

Try swapping out the 4.7kΩ resistor with different one. Also, you might want to try a different capacitor in place of the 100μF capacitor too see what effect it will have. Are you still keeping notes?

If you would like to hear the difference that a stronger capacitor makes, try connecting the 470μF capacitor to the batteries. Connect terminal 117 to 119 and terminal 118 to terminal 120. You might need to adjust the control to maintain the same pulse rate.

## Notes:

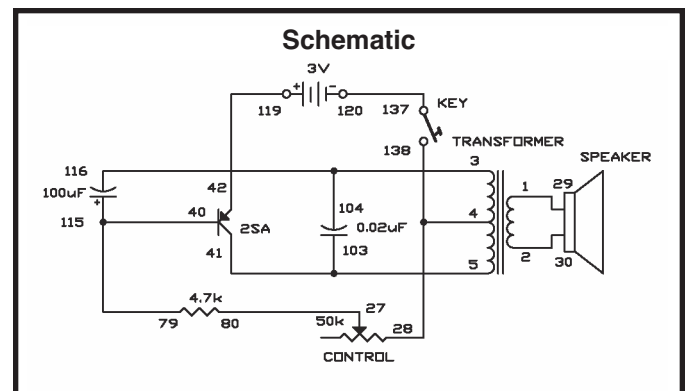

## Wiring Sequence:

- 1-29
- 2-30
- 3-104-116
- 4-28-138
- 5-41-103
- 27-80
- 40-115-79
- 42-119
- 120-137

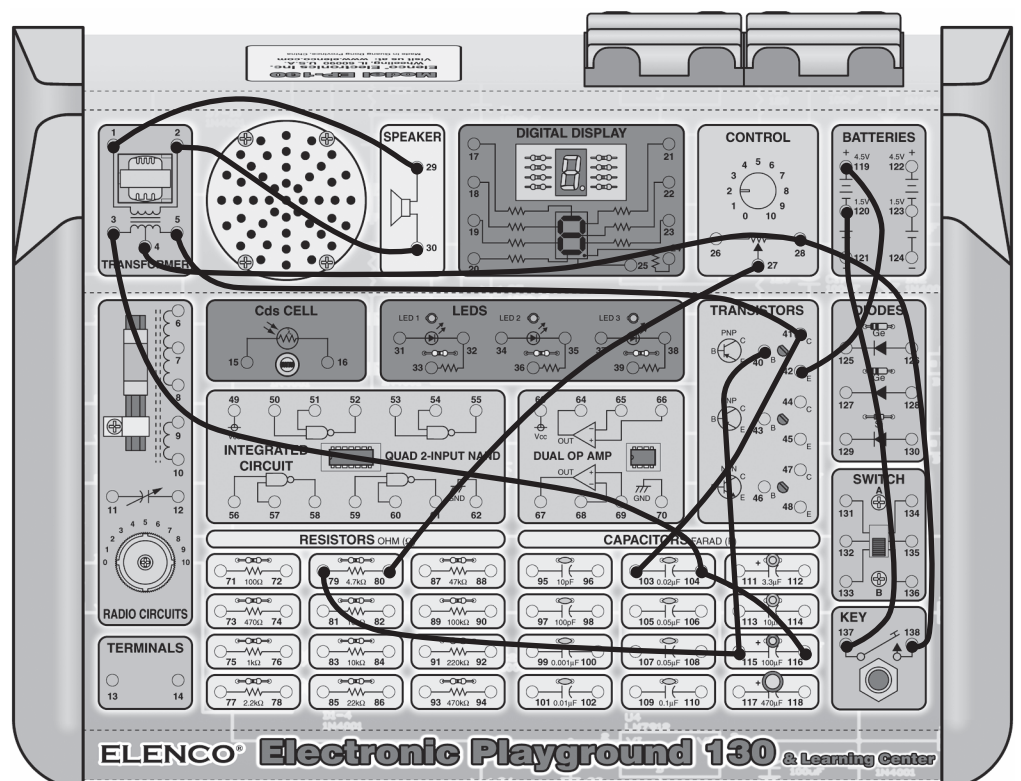

# EXPERIMENT #4: GRANDFATHER CLOCK

Does your home lack a grandfather clock? Well not any longer, with this experiment you will make your own electronic grandfather clock.

This circuit will produce clicks at approximately one-second intervals. The sound and timing together might remind you of an old grandfather clock. If you would like for it to go faster or slower then you can change out the 100kΩ resistor.

The steady ticking can put animals (and people) into a sleepy state of mind. If you have ever traveled on a train, you remember how sleepy you get from hearing the clicking sound of the wheels.

Ever scare a clock out of ticking? Shout directly into the speaker. You can briefly stop the clock! The speaker acts like a microphone as well. The sound of your voice vibrates the speaker and disturbs the electrical balance of the circuit, briefly.

## Notes:

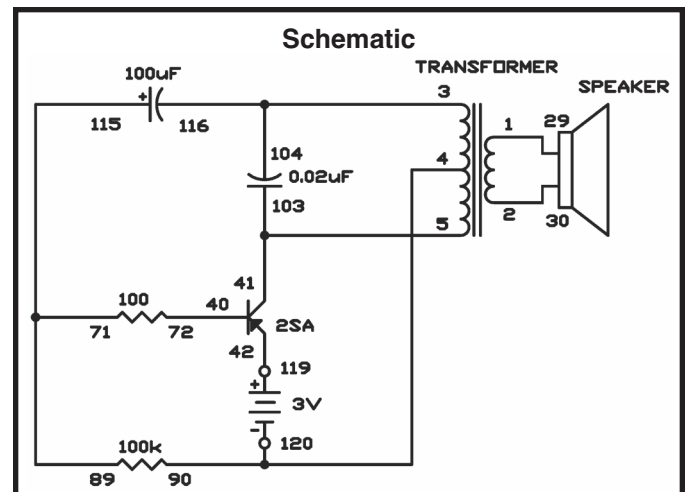

## Wiring Sequence:

- 1-29
- 2-30
- 3-104-116
- 4-90-120
- 5-41-103
- 40-72
- 42-119
- 71-89-115

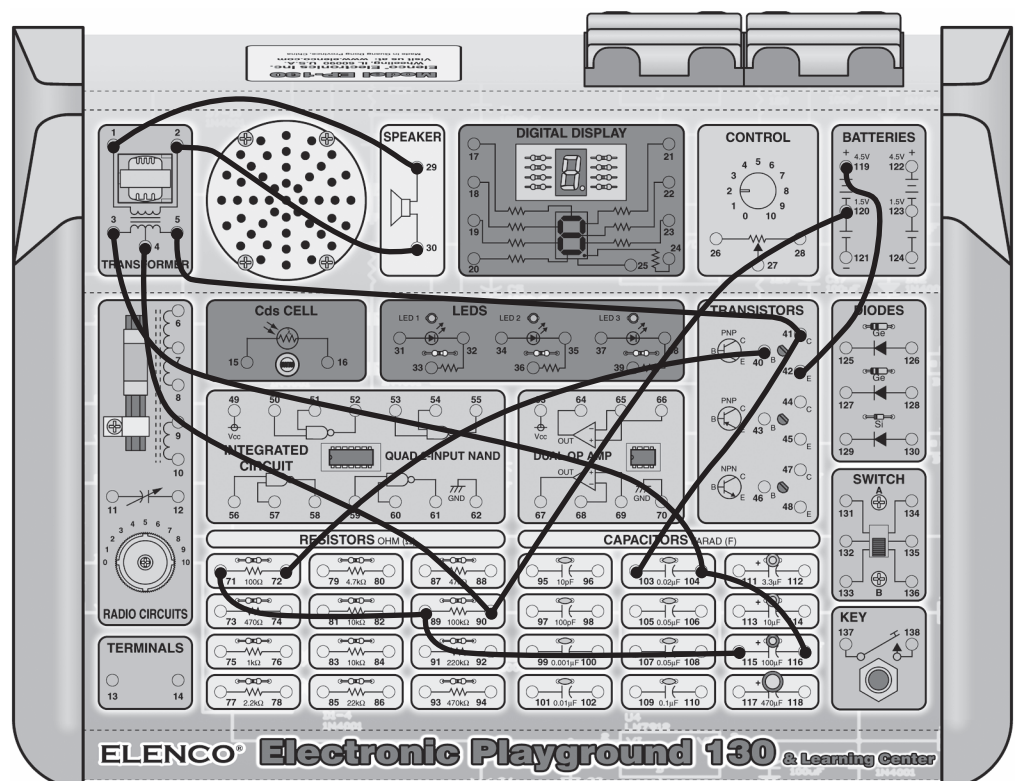

# EXPERIMENT #5: HARP

Have you ever wanted to make music just by waving your hand? Well that is just what you are going to be doing. How does this magic work? Well, the tones change based upon the amount of light that gets to the CdS cell. With a bright light the tone is higher but, if you cover the CdS with your hand, the sound gets lower.

Since the early days of vacuum-tube circuitry, this method of creating musical sound has been used. Leon Theremin was the inventor of this type of instrument, thus the instrument has been named the Theremin in his honor.

After the wiring has been completed press the key and then wave your hand over the CdS cell. You will soon be able to play music with this magical electronic instrument after just a bit of practice. Most importantly HAVE FUN!

## Notes:

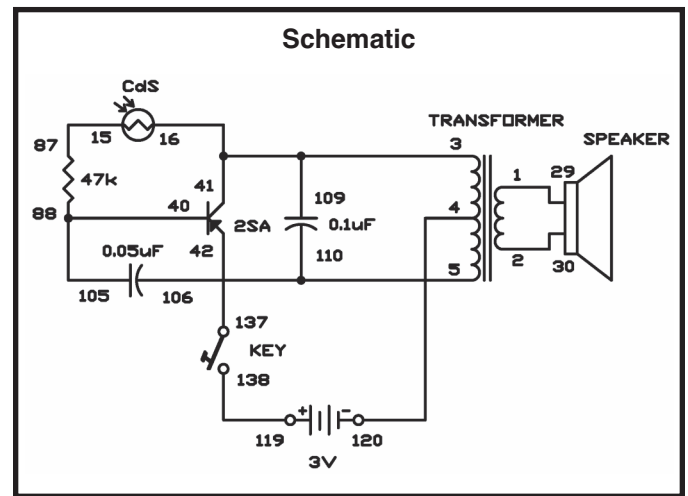

## Wiring Sequence:

- 1-29
- 2-30
- 3-16-41-109
- 4-120
- 5-106-110
- 15-87
- 40-105-88
- 42-137
- 119-138

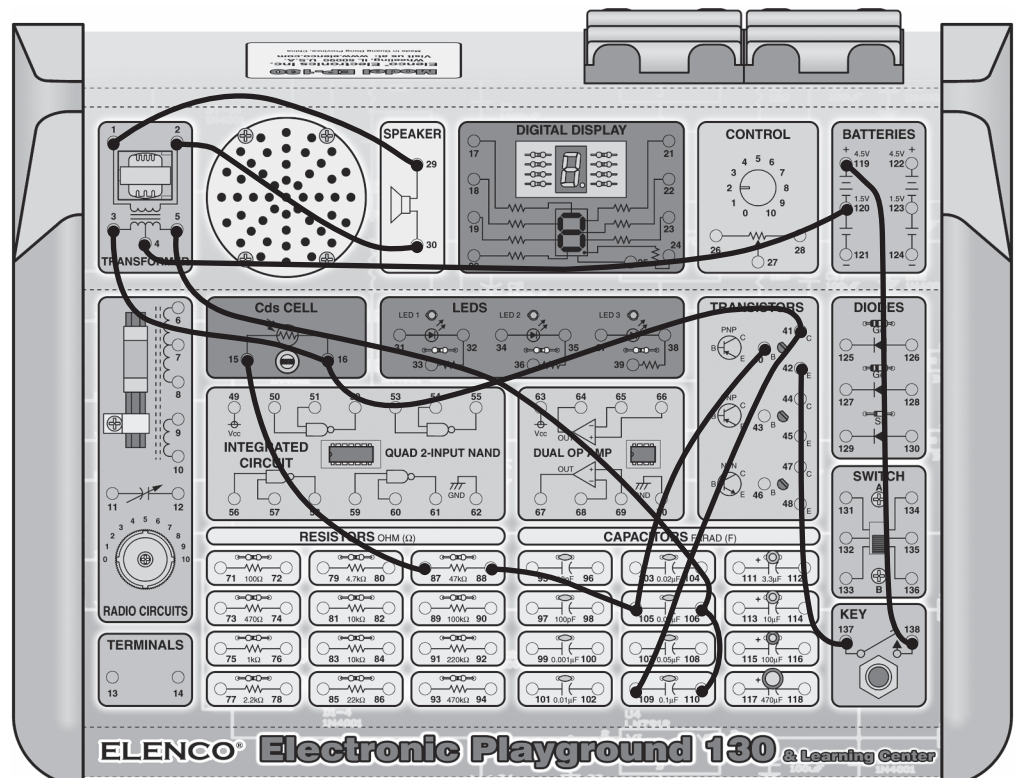



# EXPERIMENT #6: TWEETING BIRD

In this experiment you are going to make a circuit that sounds like the mockingbird.

Follow the wiring sequence and observe the drawings. Don't forget to make all the proper connections and have fun!

To finish the circuit below, slide the switch to the A position to turn on the power. No sound will come from the speakers yet. When you press the key you will hear a sound quite like a bird singing from the speaker. When you release the key, you will still be able to hear the chirping sound but eventually it will slow down and stop. The first transistor "Q1" is dropped off from the battery when the key is released. Transistor "Q2" still produces the bird sound until the controlling current from transistor "Q1" stops.

Try using a different value capacitor instead of the 10µF and the 100µF capacitors. These capacitors control the amount of electricity reaching the transistors. Listen for the difference. Make sure to start keeping notes on your experiments.

## Notes:

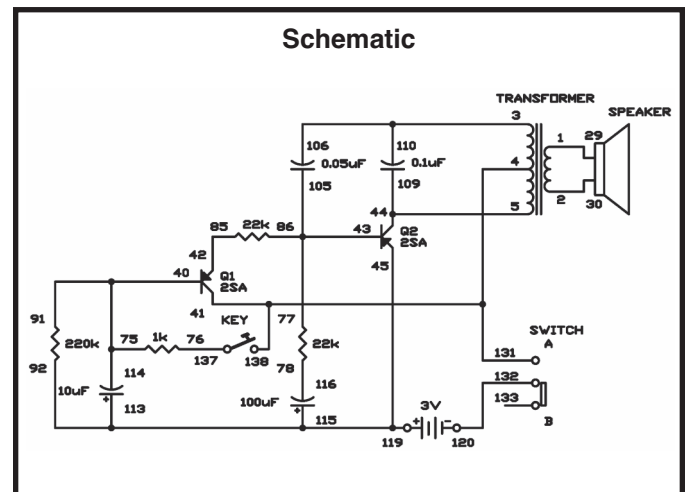

## Wiring Sequence:

- 1-29
- 2-30
- 3-106-110
- 4-41-131-138
- 5-44-109
- 40-114-91-75
- 42-85
- 43-105-86-77
- 119-45-115-113-92
- 76-137
- 78-116
- 120-132

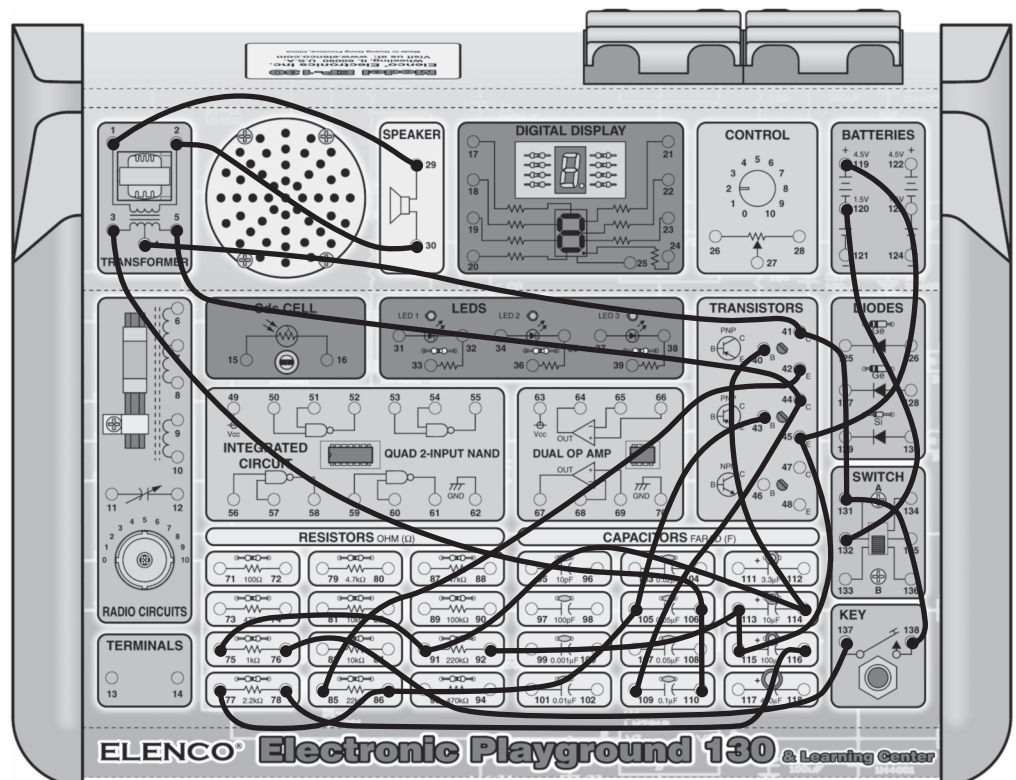

# EXPERIMENT #7: MEOWING CAT

Are you bothered by mice, do you not have a mousetrap? You should try this next experiment to help you instead—see if the sound of this cat can keep the pests out of your life.

Just follow the drawing below and the wiring sequence. To start the experiment switch the set to B. Press down on the key and release it immediately. You will hear the meow from the cat coming from the speaker. If you adjust the control knob while the cat's meow is fading away, what effect on the circuit operation does it have? Now set the switch to A and try it once more. Now it sounds as if the cat is begging for a dish of milk in a low, long sounding tone.

To produce a variety of sounds try experimenting with this circuit. Whatever you do just don't change the value of the  $0.05\mu\text{F}$  capacitor to more than  $10\mu\text{F}$  or reduce the value of the  $10\text{k}\Omega$  resistor— or else the transistor could get damaged.

## Notes:

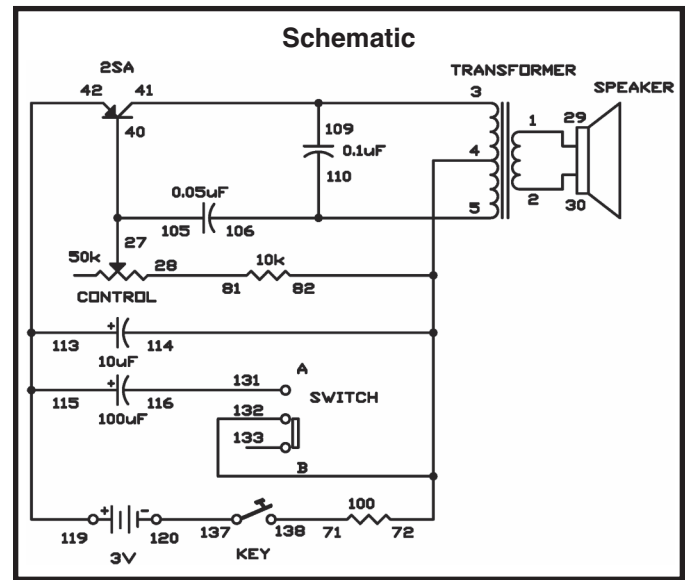

## Wiring Sequence:

- 1-29
- 2-30
- 3-41-109
- 4-72-82-132-114
- 5-106-110
- 27-40-105
- 115-113-42-119
- 71-138
- 81-28
- 116-131
- 120-137

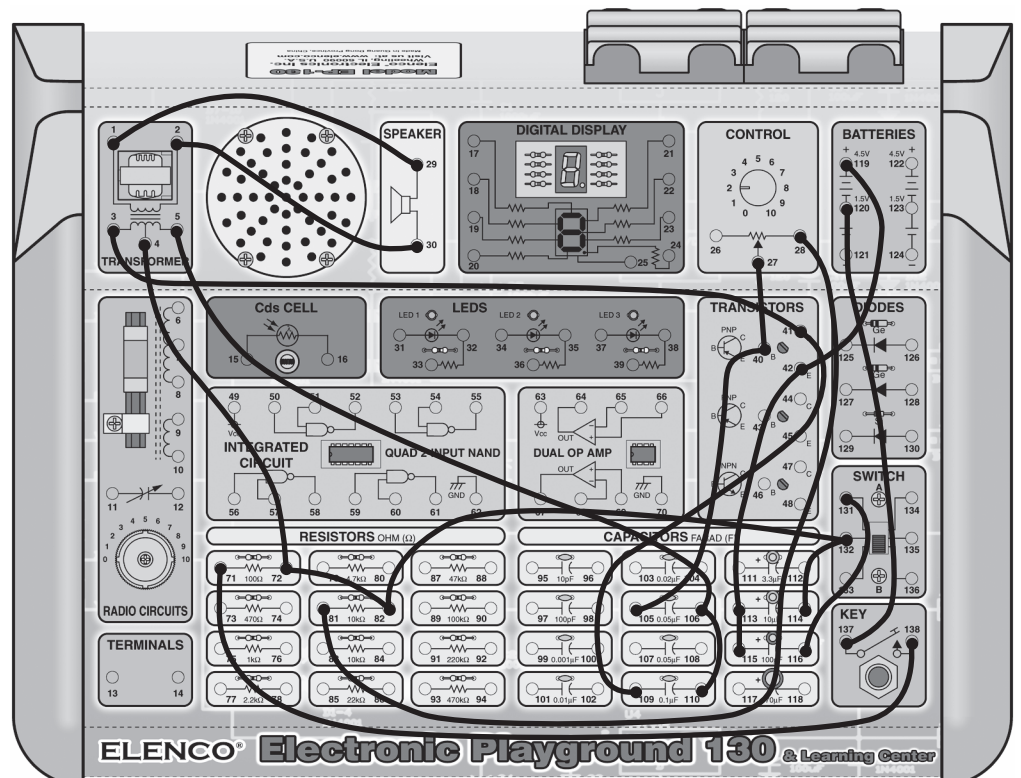

## EXPERIMENT #8: CALLING' FISH

Did you know that many marine animals communicate to each other using sound? I bet you have heard that dolphins and whales use sound for communication, but what you probably don't know is that they are not the only ones. Due to research we are able to find out that some fish are attracted to certain sounds. Making this circuit, will allow you to do some research of your own.

Once you make the last connection you are turning on the power. You should be able to hear pulses of sound coming from the speaker. The sound changes by turning the control. This circuit is a type of audio oscillator circuit, which you will learn more about later in this book.

If you have a fish tank at home or at school you should place your kit near the glass to see if the fish are attracted to the sound. Are they?

If you like to fish, you should try this out while fishing. What you need to do is attach another speaker to terminals 1 and 2 using long lengths of insulated wire. Wrap the speaker carefully in a waterproof plastic bag or place it in a tightly sealed jar. Make sure that no water is able to reach the speaker. Lower the speaker into the water, cast your fishing line, and see if you catch anything.

### Notes:

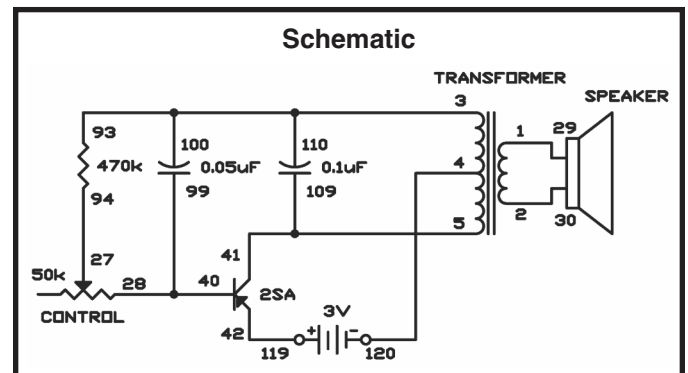

### Wiring Sequence:

- 1-29
- 2-30
- 3-93-100-110
- 4-120
- 5-41-109
- 27-94
- 28-40-99
- 42-119

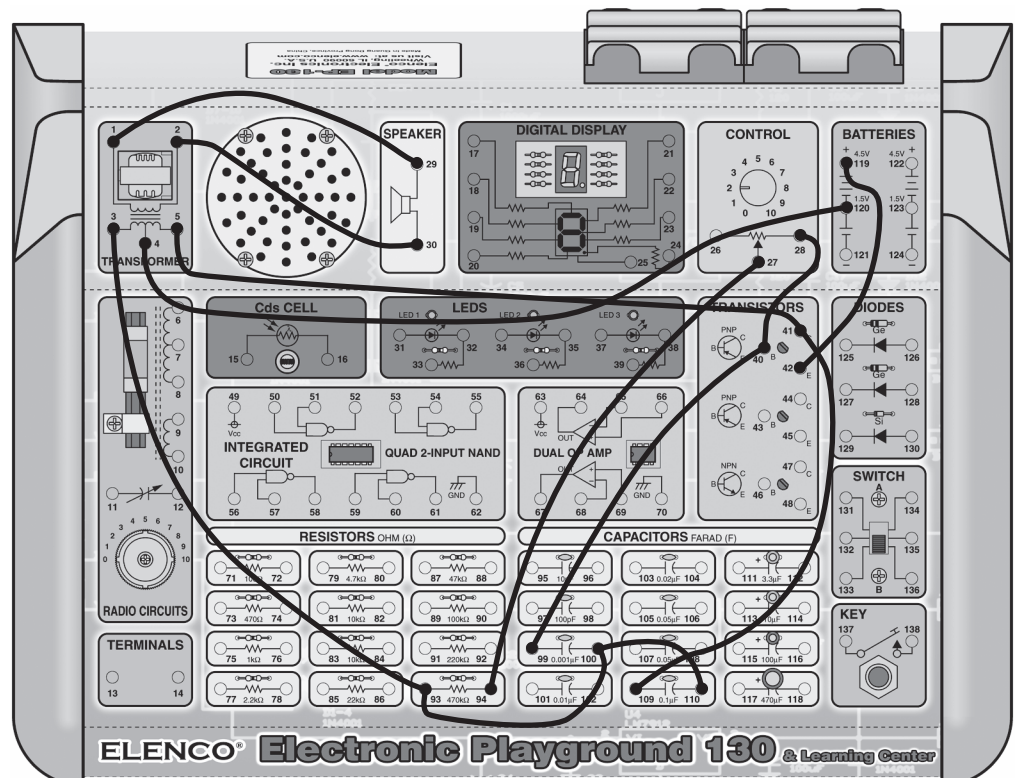

# EXPERIMENT #9: STROBE LIGHT

In this experiment you will be creating an oscillator circuit that doesn't make sound using a speaker or an earphone. Instead the circuit will produce light with an LED. This will give you an idea of how larger strobe lights work. When you press the key, watch LED 1. At certain intervals the light turns on and off. With the 50kΩ control you can control the rate of blinking.

## Notes:

Try substituting a capacitor with a lower value for the 100μF capacitor to see how an oscillator works. Make a prediction about what you think will happen? Were you correct?

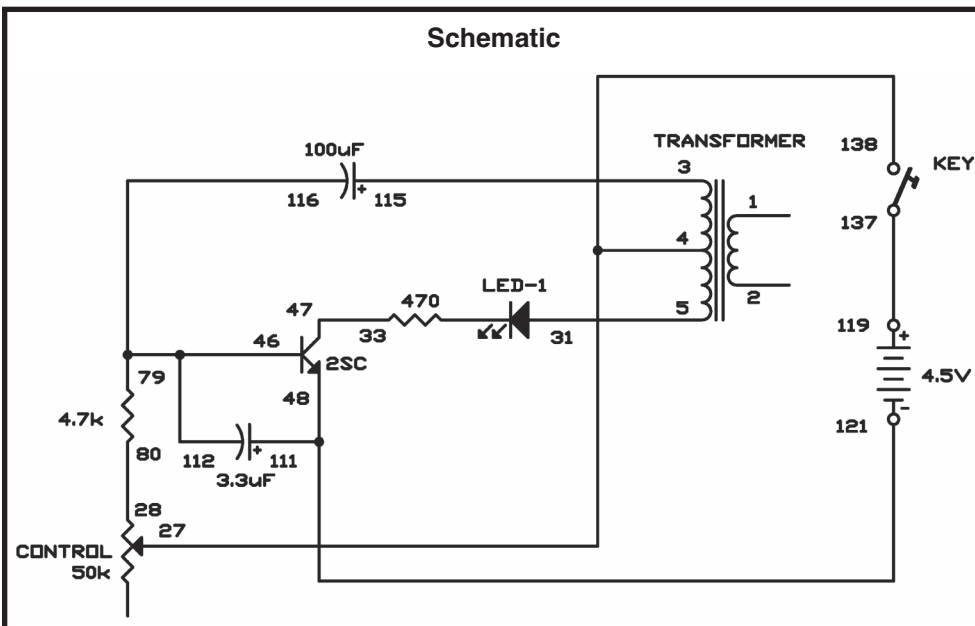

## Wiring Sequence:

- 3-115
- 4-27-138
- 5-31
- 28-80
- 33-47
- 79-116-112-46
- 111-48-121
- 119-137

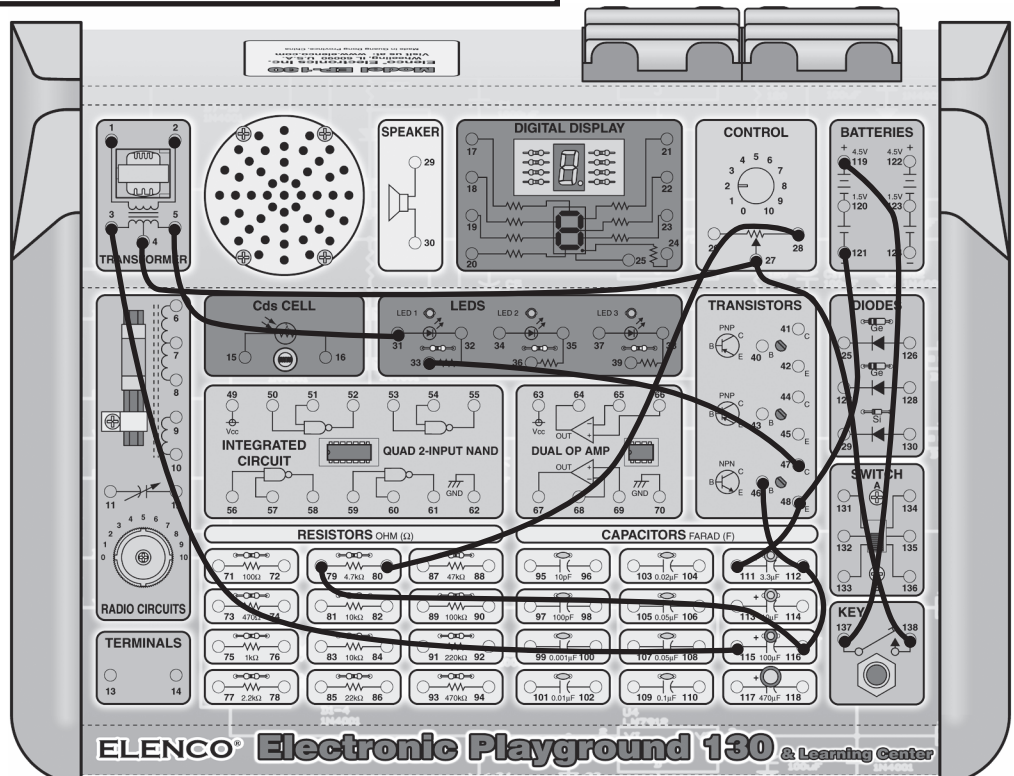

## EXPERIMENT #10: SOUND EFFECTS FOR HORROR MOVIES

The sounds that you will hear from this circuit will remind you of the music you hear in horror movies. Once you wire the project, use your special light shield and your hand to change the light amount that shines onto the CdS cell. This changes the pitch of the music.

The pitch of a sound is determined by the sound wave's frequency, which is the number of cycles of electromagnetic energy per second. The amount of light on the CdS cell determines the resistance of the cell. The more resistance you have the slower the frequency of the musical sound waves. The oscillator circuit produces the basic sound wave.

Frequency modulation, or FM, is when the frequency of an oscillator is controlled by part of the circuit. An FM radio signal is similar to this but at higher frequencies.

### Notes:

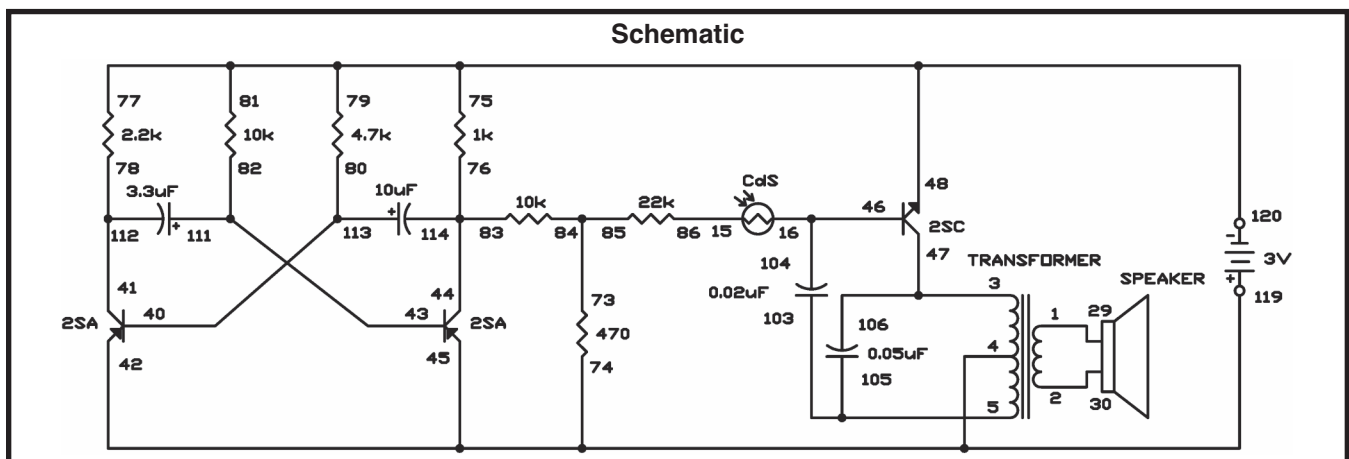

### Wiring Sequence:

- 1-29
- 2-30
- 3-47-106
- 4-74-45-42-119
- 5-103-105
- 15-86
- 16-46-104
- 40-113-80
- 41-112-78
- 44-114-83-76
- 120-48-81-79-75-77
- 73-85-84

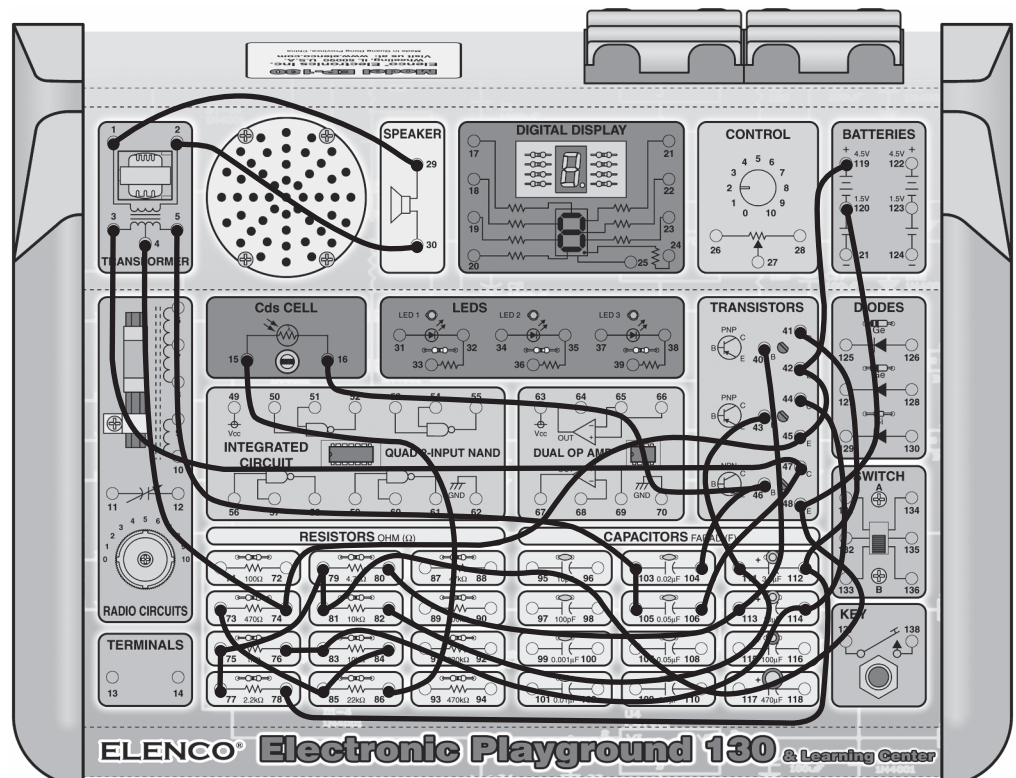

# EXPERIMENT #11: MACHINE GUN OSCILLATOR

This circuit is what engineers refer to as a “pulse oscillator”. It will make machine gun like sounds.

There are many different ways to make oscillators. In this kit, you will build several of them and later on, you will be told on how they work. In the meantime, we will just tell you what an oscillator is.

An oscillator is a circuit that goes from high to low output on its own, or in other words, it turns itself on and off. A pulse oscillator is controlled from pulses, like the pulses made from a capacitor charging and discharging. The oscillator in this kit turns off and on slowly. However, some oscillators turn off and on many thousands of times per second. Slower oscillators can often be seen controlling blinking lights, such as turn signals in a car or truck. “Fast” oscillators are used to produce sound. The fastest oscillators produce radio frequency signals known as “RF signals”. The RF signal oscillators turn on and off millions of times per second!

The amount of times an oscillator turns off and on each second is called the frequency of the oscillator. Frequency is measured in units called hertz (Hz). The frequency of this oscillator is about 1 to 12Hz. The frequency of a radio signal oscillator would be measured in either MHz (megahertz, meaning a million hertz) or kHz (kilohertz, meaning a thousand hertz).

Once you finish wiring, press the key to start the oscillator. The 50kΩ resistor is the control; you can swap it out with other resistors to change the sound from a few pulses per second to a dozen or so per second. Also, you can change the frequency of this oscillator circuit by swapping out other capacitors in place of the 10μF. Remember to observe the correct polarity!

### Notes:

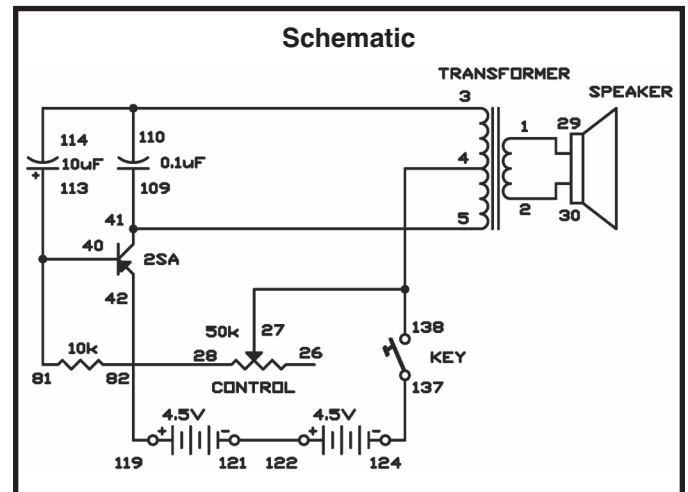

### Wiring Sequence:

- 1-29
- 2-30
- 3-110-114
- 4-27-138
- 5-41-109
- 28-82
- 40-113-81
- 42-119
- 121-122
- 124-137

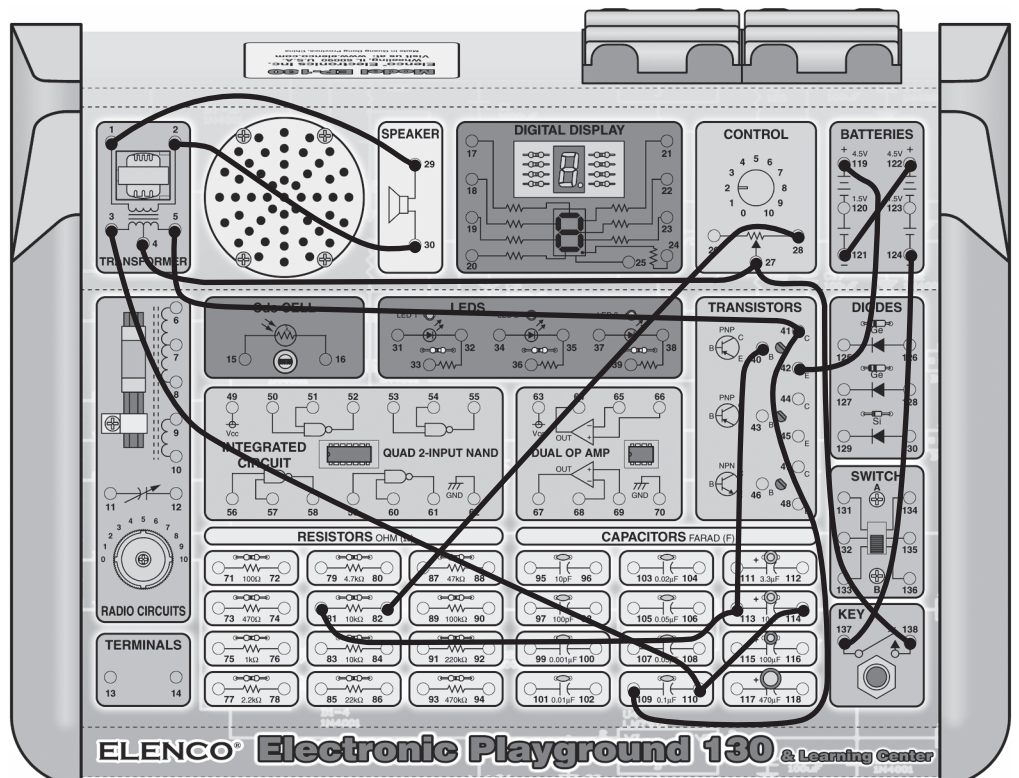

ELENCO® Electronic Playground 130 & Learning Center

# EXPERIMENT #12: MOTORCYCLE MANIA

Have you ever tried to steer a bicycle or a motorcycle with just four fingers? This would be dangerous on a real motorcycle but on electronic version it is a lot of fun!

To do this project, connect the components following the wiring sequence. Next grasp the metal exposed ends of the two long wires (connected to terminals 110 and 81) in between your index finger and thumb of your left and right hands. Now vary your grip/pressure and listen as the sound changes in the speaker. Due to the grip you use the sound changes.

You can create different sounds by controlling the light that into the CdS cell. If you have a strong light on the CdS cell you can control the entire operation by putting more pressure on the wires within your hands. Make a shadow over the CdS cell with your hand and see what happens.

By holding the ends of the wires, you are making yourself an extension of the circuit- thus a human resistor. When you change your grip the resistance changes in the projects current. The sound from the circuit will make a real motorcycle noise and with practice you can do it real well. By doing this you can make the motorcycle idle as well as race.

Experiment with different values for the  $0.1\mu\text{F}$  and  $0.05\mu\text{F}$  capacitors, but make sure you don't use values above  $10\mu\text{F}$  or you may damage the transistor.

### Notes:

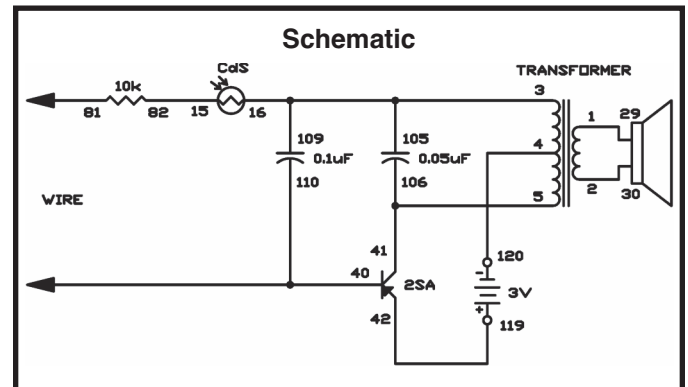

### Wiring Sequence:

- 1-29
- 2-30
- 3-16-105-109
- 4-120
- 5-41-106
- 15-82
- 40-110-WIRE
- 42-119
- 81-WIRE

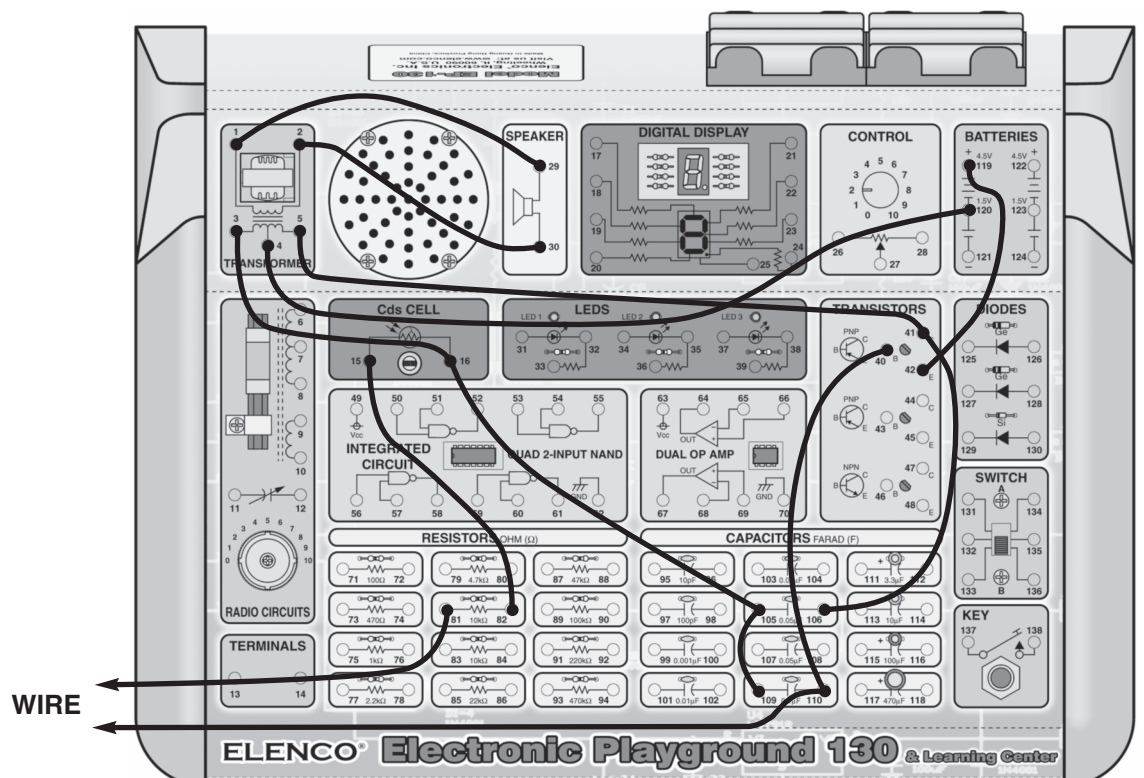

# EXPERIMENT #13: VISION TEST

This circuit produces short pulses. After you close the key, the LED display shows 1 for a second and then turns off, even when you keep pressing the key.

You could create a game with this circuit. Display a number or a letter on the LED display and then have the players tell you what number it is. You change numbers or letters on the display by just changing the wiring to the display. Connect the terminals to form the letters or numbers to terminal 71 (in the place of the 21 and 23 terminals). Connections for the number 3 would be 17-21-22-23-20-71.

You can try different values of capacitors to see their effects. Don't use a capacitor with a value higher than 10µF or the excessive current can damage the transistor.

## Notes:

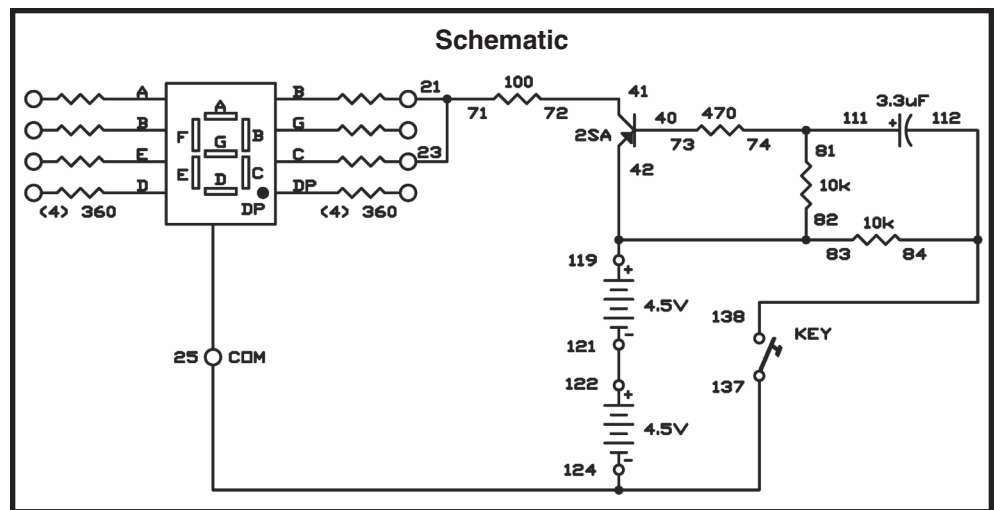

## Wiring Sequence:

- 21-23-71
- 25-124-137
- 40-73
- 41-72
- 82-83-42-119
- 74-81-111
- 84-112-138
- 121-122

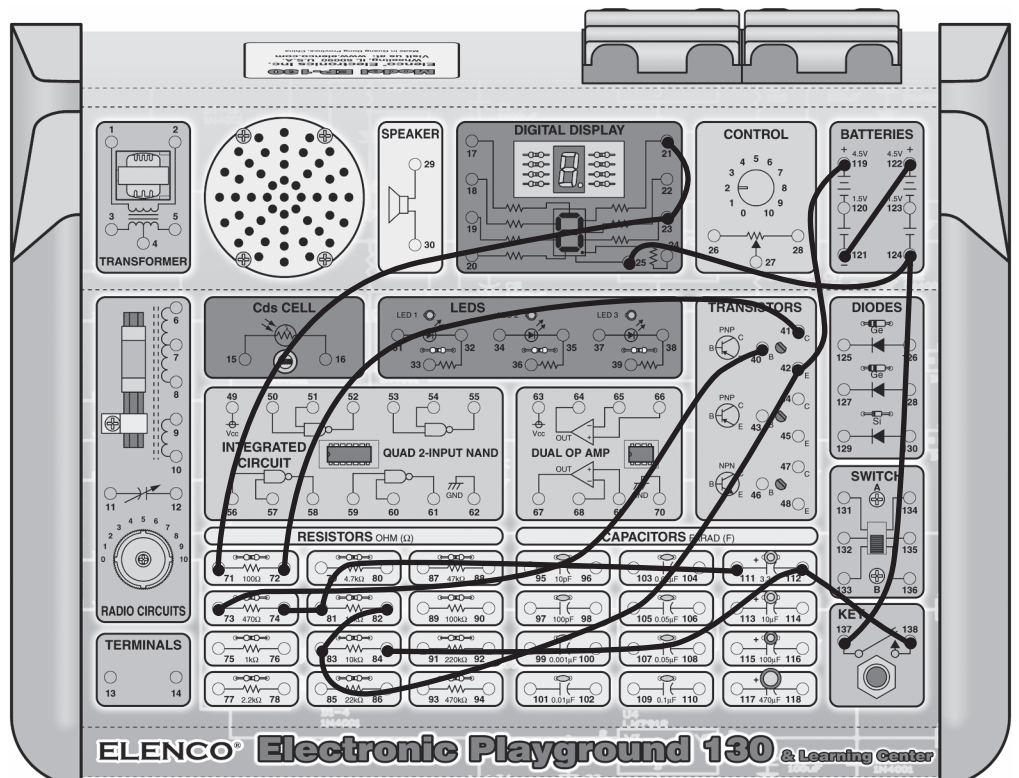



# EXPERIMENT #14: PATROL CAR SIREN

With this experiment you may want to be careful not to confuse your neighbors. This experiment sounds as like a loud siren just like the real sirens on police cars and ambulances. The tone is initially high but as you close the key the tone gets lower. You are able to control the tone just as the police and ambulance drivers do.

## Notes:

The oscillator circuit being used is the same type used in many other experiments in this kit. Press the key and another capacitor is added to the circuit to slow the action of the oscillator circuit.

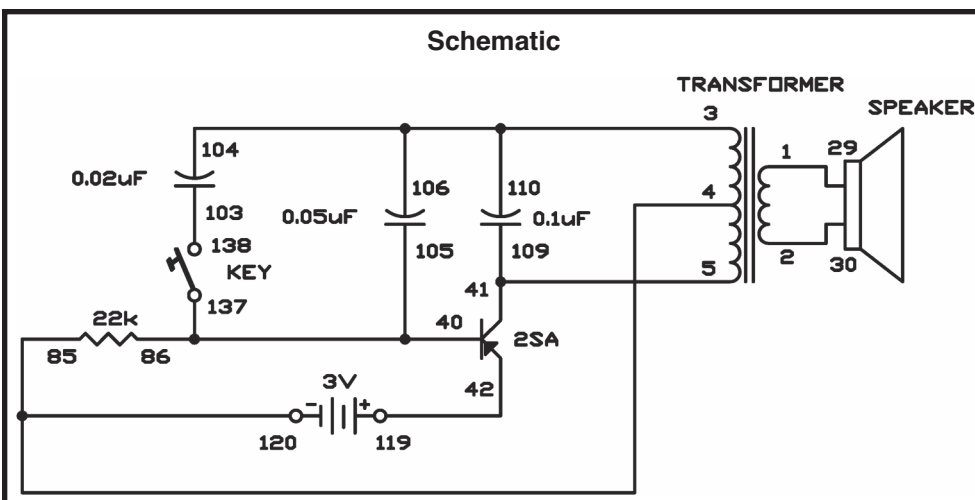

## Wiring Sequence:

- 1-29
- 2-30
- 3-104-106-110
- 4-85-120
- 5-41-109
- 40-137-105-86
- 103-138
- 42-119

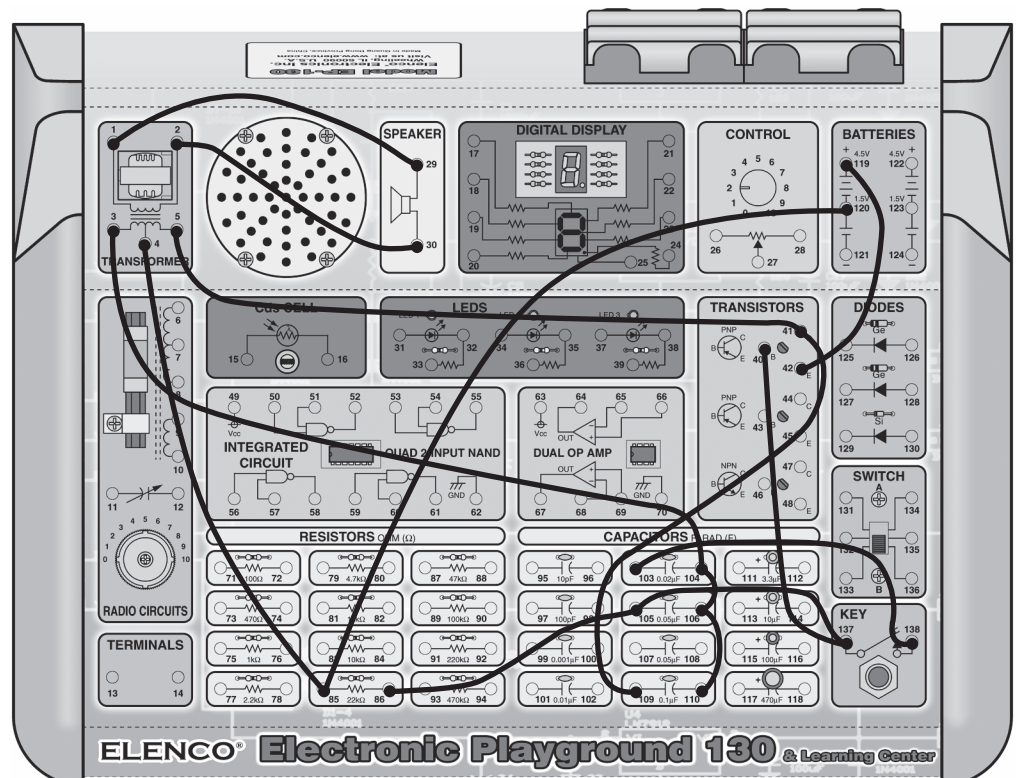

## **II. BASIC ELECTRONICS CIRCUITS**

---



## A MAJOR CHANGE

Until now, in addition to the wiring sequences you have had drawings to help guide you in the wiring connections. The rest of the projects will have just the schematic diagram without the circuit drawings.

A schematic diagram is like a road map but it is used for electronic circuits. It shows you how different parts connect together and how electricity flows through a circuit. Electronics engineers and technicians use schematics to help guide them through circuits.

You don't need to build your circuits from the schematic diagrams by themselves. We have added the number of terminals to where you will be making the wiring connections on each schematic, to help you out - a line between numbers on the schematic means that you should connect a wire between those terminals in your kit. Every part in your kit has a schematic symbol all of its own. At the beginning of this manual you will find a picture of each part with its schematic symbol as well as a short description.

As you will start to notice, the schematics have some lines that cross each other and that there is a dot at the crossing point. This means that the two wires which are represented by the lines, are to be connected at the point where the dot is located (you will find the terminal number next to the dot). If there is not a dot where the lines cross, this means that the wires do not connect (you won't see a terminal number if the wires don't cross).

Lines Are Connected  /  Lines Not Connected

The schematic diagrams will look confusing at first but they are simple once you have some practice using them. Don't get discouraged if you get confused at first. You will be constructing circuits in no time by just looking at the schematic diagrams.

To be able to read schematic diagrams is important for anyone getting into the field of electronics. Many electronics books and magazines display intricate circuits only in schematic form. A schematic is also shorter and more accurate way to show a circuit rather than a written form.

## EXPERIMENT #15: LIGHT DIMMER

Ever thought you could use a capacitor to dim a light? Try this project. After you finish the wiring, set the switch to A. Then the LED segments will light up slowly and show an L. Once the LED reaches its brightest point it will stay on. Move the switch to B and watch as the L fades away.

Look at the schematic. When the switch is on, the current flows from the battery to the 100 $\mu$ F capacitor to charge. Once the capacitor reaches full charge, electricity flows to the transistor base and turns it on gradually, which turns the LED on. Eventually the capacitor will be completely charged and then the current flows continuingly to the base of the transistor and the LED stays on.

When the switch is turned off and you remove the battery from the circuit, then the capacitor starts to discharge through the transistor and the LED. The L dims until the discharge of the 100 $\mu$ F is finished.

If you want a slower dimmer circuit, all you have to do is replace the 100 $\mu$ F capacitor with the 470 $\mu$ F capacitor. Replace connections 25-116-124 with connections 25-118-124. Be patient because the LED does eventually come on.

Go back to project 2 (the police siren) and see if you can figure out why the siren goes from high to low as you press and then release the key.

**Hint:** the 10 $\mu$ F capacitor charges when you close the key.

**Notes:**

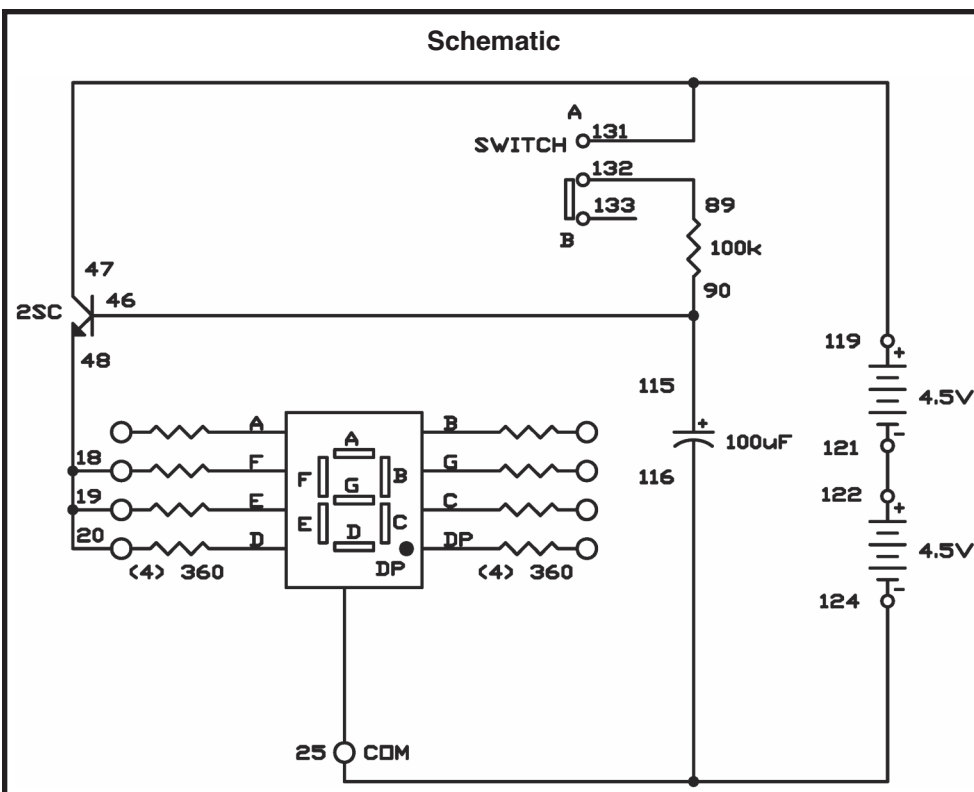

**Wiring Sequence:**

- 18-19-20-48
- 25-116-124
- 46-115-90
- 119-47-131
- 89-132
- 121-122

## EXPERIMENT #16: FLIP FLOPPING

How about we take a break? This circuit is for entertainment. The numbers 1 and 2 will flash on the display in the circuit. This might remind you of some neon signs that have eye-catching advertisements on them.

A “flip-flop” circuit controls the LED display in this experiment. In later projects you will be learning more about flip-flop circuits. Try a different value for the capacitors to see the effects on the operation speed. Try and rewire the LED display to flash numbers other than 1 and 2. Try placing higher values in place of the 22kΩ and 4.7kΩ resistors. Do not use lower values for any of the resistors or else you could damage the transistors.

**Notes:**

### Wiring Sequence:

- 17-19-20-22-41-116-82
- 21-42-45-119
- 23-44-118-84
- 79-81-83-85-25-124
- 80-117-40
- 86-115-43
- 121-122

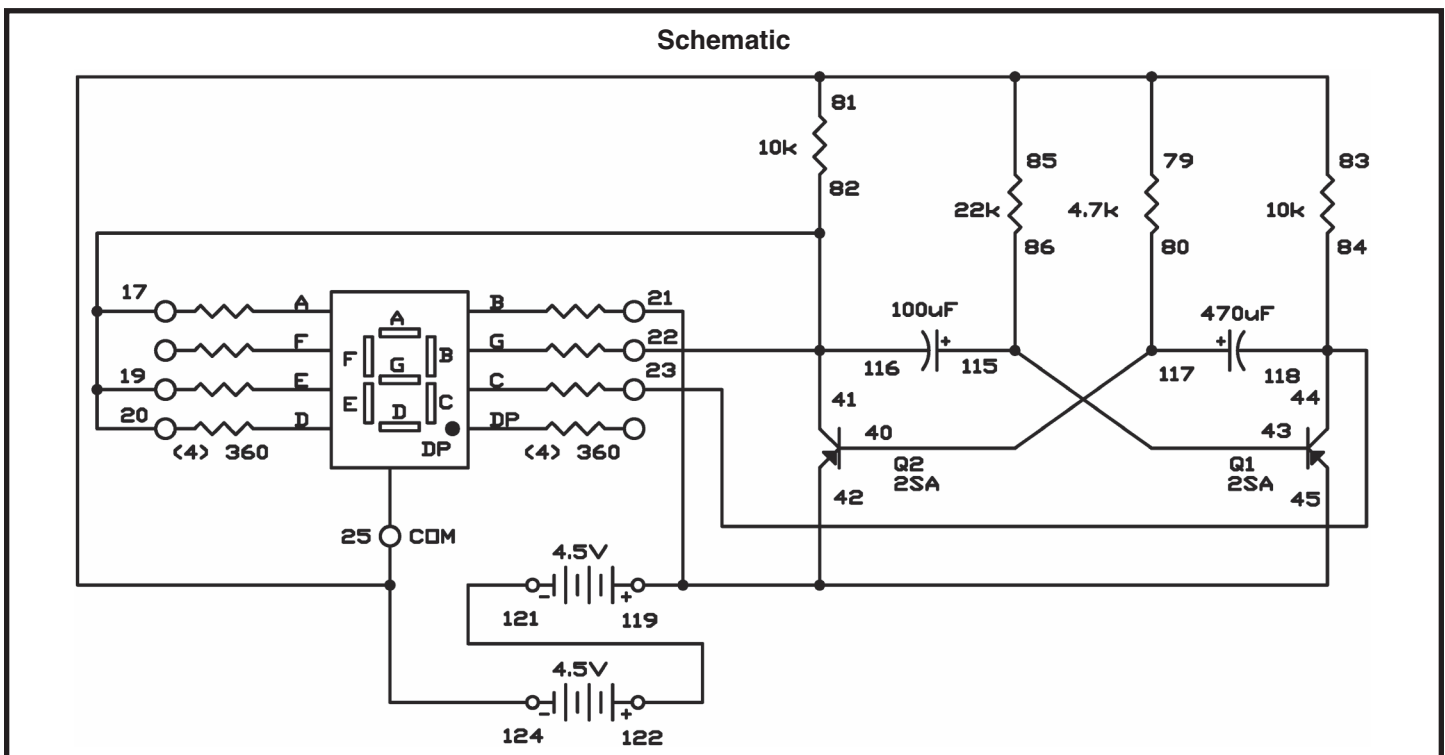

## EXPERIMENT #17: CAPACITOR DISCHARGE FLASH

In this circuit single pulses of high voltage electric energy are generated by suddenly discharging a charged capacitor through a transformer. Automobile ignition systems use a similar capacitor-discharge reaction.

The operation of this circuit is simple but the concepts involved are important to helping you understand more complicated circuits. If you have access to an oscilloscope, you can scientifically measure the energy that is discharged through the transformer.

The 470 $\mu$ F capacitor stores up energy as the batteries supply millions of electrons to the capacitors negative electrode. Meanwhile the batteries draw the same number of electrons from the capacitors positive electrode so that the positive electrode is lacking electrons. The current must pass through the 4.7k $\Omega$  resistor, so it requires at least 12 seconds for the capacitor to receive the full 9V charge from the batteries.

The amount of charge a capacitor can store depends on its capacitance value and the voltage applied across it. This represents the amount of electrons displaced in the electrode.

The amount of electrons in a capacitor's electrode is measured in coulombs. The quantity of one coulomb is 6,280,000,000,000,000 electrons ( $6.25 \times 10^{18}$ ).

The charge in either electrode of the capacitor is determined by multiplying the capacitance (C) by the voltage across the capacitor (E). ( $Q = C \times E$ ). The 470 $\mu$ F ( $470 \times 10^{-6}$ F) capacitor at 9V is calculated as follows:

$$Q = C \times E = 470 \times 10^{-6} \times 9 = 4.23 \times 10^{-3} \text{ coulombs}$$

or:

$$470 \times 0.000001 \times 9 = 4.23 \times 10^{-3} \text{ coulombs} \\ (265,564,400,000,000 \text{ electrons})$$

Pressing the key causes the above number of electrons to pass through the transformer winding in a very short time and induces a high voltage in the secondary winding. Thus causing the LED to flash.

An oscilloscope is an electronics measurement instrument used by engineers and technicians. If you have access to one, connect it (with help from someone who knows how to use it) to terminal 3 and terminal 5 of the transformer to indicate the presence of 90V or more. The indicated voltage is

produced when the charge held by the capacitor is released into the transformer.

### Notes:

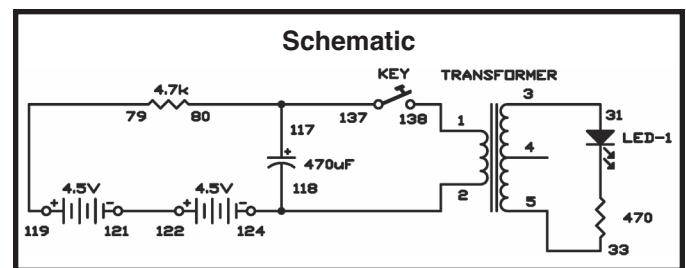

### Wiring Sequence:

- 1-138
- 2-118-124
- 3-31
- 5-33
- 79-119
- 80-117-137
- 121-122

## EXPERIMENT #18: TRANSISTOR ACTION

There are three connections made on a transistor; one of these (the base) controls the current between the other two connections. The important rule to remember for transistors is: a transistor is turned on when a certain voltage is applied to the base. A positive voltage turns on an NPN type transistor. A negative voltage turns on a PNP type transistor.

In this project the LED display shows which transistor is on by lighting either the top or the bottom half. This demonstrates how a positive voltage controls an NPN transistor and the PNP transistor is controlled by a negative voltage.

After the connections are made the NPN transistor will be turned on because the positive voltage through the 1kΩ resistor is applied to the base. This turns on the upper half of the LED display. Simultaneously the PNP is off because current cannot flow to its base. (The current flows from the PNP emitter to the NPN transistor base; however, this flow from the PNP base is blocked by the diode.)

The NPN is turned off if you press the key, because current is diverted away from its base. The PNP is turned on simultaneously because now current can flow from its base through the 4.7kΩ resistor. As a result, the upper LED segments turn off and the lower segments turn on.

### Notes:

### Wiring Sequence:

- 18-17-21-48
- 19-20-23-41
- 25-124-138
- 40-80-77
- 75-78-47-42-119
- 76-46-126
- 79-137-125
- 121-122

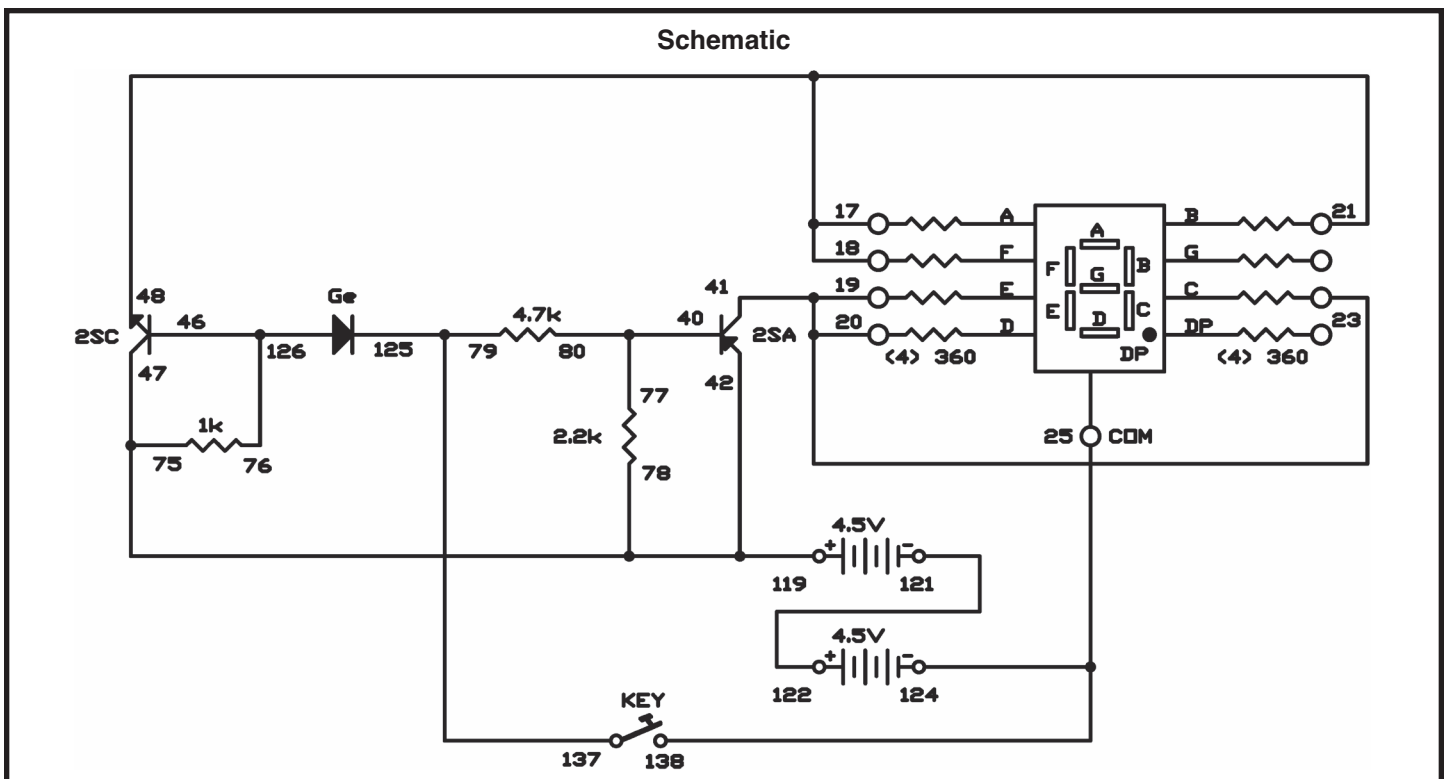

## EXPERIMENT #19: SERIES AND PARALLEL CAPACITORS

Some of the handiest items in your kit are the capacitors. They store electricity, smooth out pulsing electricity into a steady flow and let some electric current flow while blocking other current. This circuit allows you to compare the effects of capacitors connected in both series and parallel.

Once you have finished wiring this project, set the switch to B. Next connect terminals 13 and 14. You will hear a sound coming from the speaker. In this case, electricity is flowing through the  $0.01\mu\text{F}$  capacitor (refer to the schematic to help understand this). Press the key now. What happens?

You will hear a lower-pitched sound coming from the speaker, because the  $0.05\mu\text{F}$  capacitor has been added in parallel to the first capacitor. Current now flows through both capacitors at the same time, through two channels that are separate. What do you think happens to the total capacitance when you connect two capacitors in parallel?

You may have guessed wrong. When connected in parallel, two capacitors make the total capacitance increase. The tone is lower because the increased capacitance causes it to be.

Now release the key and then move the switch from B to A. While the switch is set to A, do not press the key. Now what do you hear?

You now hear a high-pitched sound coming from the speaker. This is due to the  $0.05\mu\text{F}$  and  $0.01\mu\text{F}$  capacitors are now connected in series – the flow of the current goes directly from one to the other. The total of the capacitance in the circuit is less than the

smallest capacitor in the series connection. The higher-pitch sound is caused by the lower capacitance.

### Notes:

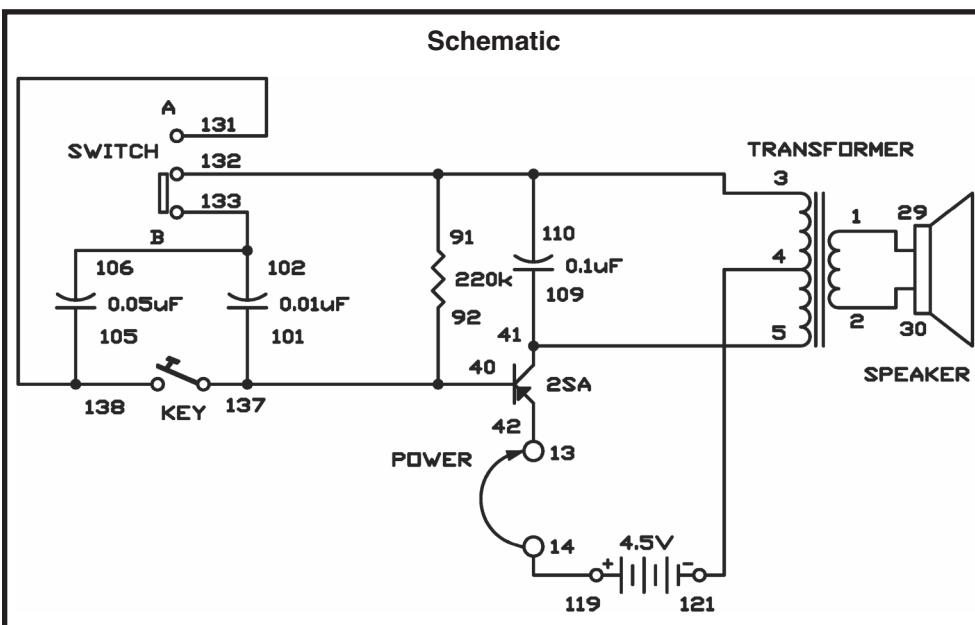

### Wiring Sequence:

- 1-29
- 2-30
- 3-91-110-132
- 4-121
- 5-41-109
- 13-42
- 14-119
- 40-92-101-137
- 102-106-133
- 105-131-138
- 13-14 (POWER)



## EXPERIMENT #20: TRANSISTOR SWITCHING

In this experiment you study the switching action of transistors in turning an LED on. You will be using two different transistors - one of the two PNP types and the NPN type included in your kit. PNP and the NPN refers to the arrangement of the semiconductor materials inside the transistors.

The NPN transistor at the bottom of the schematic stays on due to the 47kΩ resistor supplying voltage to its base. Making the connection through the 22kΩ resistor causes the PNP transistor at the top of the schematic to turn on.

The resistance of the 22kΩ is approximately half of that of the 47kΩ resistor, so the current supplied to the base of the PNP transistor is about twice that of the NPN. Therefore the PNP is turned on “greater” than the NPN.

Connect the circuit and then press the key: 1 is displayed. To increase the base current for the NPN transistor, you have to decrease the value of the 47kΩ resistor connected to the base – terminal 46. To do this simply disconnect between 87 and 88 and then replace them with connections to another resistor. For example, change connection 87-42 to 83-42 and connection 46-88 to 84-46, to change the 47kΩ to a 10kΩ resistor. Every time that you lower the resistor value more current is then supplied to the base of the transistor, and the LED display lights a little brighter when you press the key. If you decrease the resistance below 1kΩ the transistor may burn out.

Next, change the resistors to 10kΩ and then press the key. Use terminals 83 and 84 and terminals 81 and 82. With the transistors both fully on the brightness should not change much. If change does occur check your batteries.

### Notes:

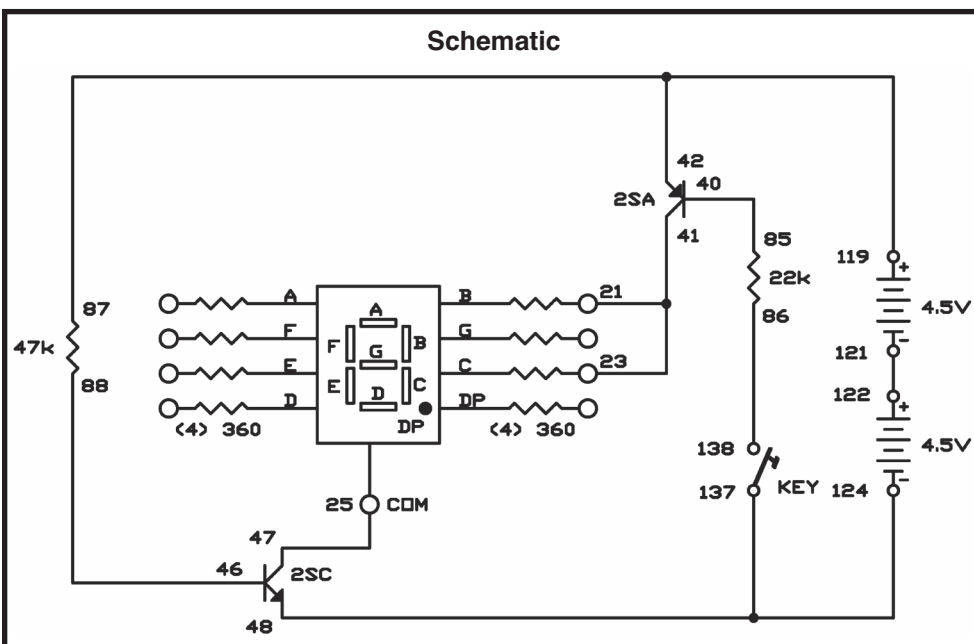

### Wiring Sequence:

- 21-23-41
- 25-47
- 40-85
- 87-42-119
- 46-88
- 124-48-137
- 86-138
- 121-122

## EXPERIMENT #21: SERIES AND PARALLEL RESISTORS

In this project, you will discover what happens when you connect resistors in series and in parallel. You will see the LED-1 on the panel flash on and off when you finish wiring.

See what happens to the LED on side A and then on side B when you slide the switch. There is no change at all. The schematic shows that two 10kΩ resistors are connected in series to side A of the switch, and one 22kΩ resistor is connected to side B. The resistors connected in series on side A are equal to the sum of each resistor's value – so 20kΩ is the total resistance of the resistors. This is about the same as 22kΩ resistance in side B. So the LED shows no change when you move the switch.

The LED becomes brighter when you press the key. By looking at the schematic, you will see that resistor R1 (470kΩ) is connected to the LED in series. The resistor controls the flow of current to the LED. The total resistance decreases when you press the key, R1 and resistor R2 (100Ω) are connected in parallel. The LED becomes brighter because of the amount of current flowing to it increases, when the amount of resistance decreases.

Calculating the total resistance for resistors connected in parallel is not as easy as when resistors are connected in series. You must multiply the values

together, and then divide the product by the sum of values. In this case, the total resistance is:

$$\frac{470 \times 100}{(470 + 100)} = 82\Omega$$

Connect now terminals 13-14. As shown in the schematic, this connects the 22kΩ resistor in parallel with the two 10kΩ resistors. Is there any change in the LED? The flashes on and off of the LED are at shorter intervals because the resistance connected to the slide switch decreases. Try to calculate the new resistance value. The new value is about 10.5kΩ.

This circuit is known as a multivibrator. A multivibrator is an oscillator that uses components that direct current back to each other. From the schematic you can see that the 10μF and the 100μF capacitors discharge through the transistors. This multivibrator circuit controls the oscillations to create the flash through the LED at certain intervals. You can now see that resistors and capacitors have opposite effects when they are connected in series or parallel. Be careful - it is easy to get confused about which one increases or decreases in strength.

### Notes:

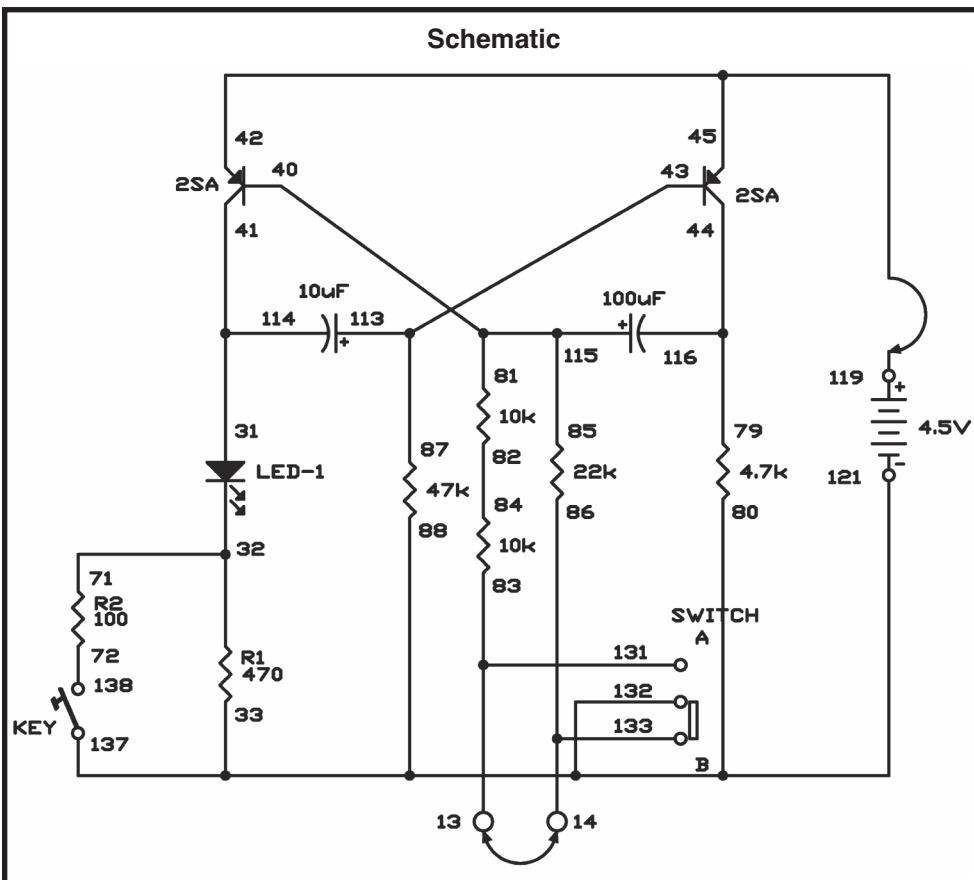

### Wiring Sequence:

- 31-41-114
- 79-116-44
- 40-115-85-81
- 43-113-87
- 32-71
- 72-138
- 82-84
- 13-83-131
- 14-86-133
- 33-80-88-137-132-121
- 45-42-119

## EXPERIMENT #22: AMPLIFY THE SOUND

A two-transistor amplifier is used in this circuit. In an amplifier, a small signal is used to produce or control a large signal. This circuit is similar to an early model transistor hearing aid amplifier.

Your kit's speaker can change sound pressure into a weak voltage. The transformer increases the voltage, and which is then applied to the NPN transistor through the 3.3 $\mu$ F capacitor.

Now it is time to talk about the transformer. The transformer has a copper wire wound hundred of turns. We call this a coil. A transformer has two coils separated by an iron plate.

A magnetic field is created when electricity flows through a coil. The reverse is also true - if a coil is subjected to a change in its magnetic field strength, electricity flows through it. The magnetic field created depends on the number of windings in the coil, so when electricity flows through the first coil (the primary coil), the voltage at the second coil (the secondary coil) will be different if the number of windings is different. Induction is the creation of an electric charge using a magnetic field. Now go back to project 17 and think of how a large voltage is induced at the secondary side when 9V is applied to the primary side of the transformer.

### Notes:

### Wiring Sequence:

- 1-29
- 2-30
- 3-112
- 5-124-48-116-102-78-13-EARPHONE
- 93-109-40
- 41-94-77-14-EARPHONE
- 42-72
- 91-100-101-111-46
- 75-92-99-110-47
- 71-76-115-119
- 121-122

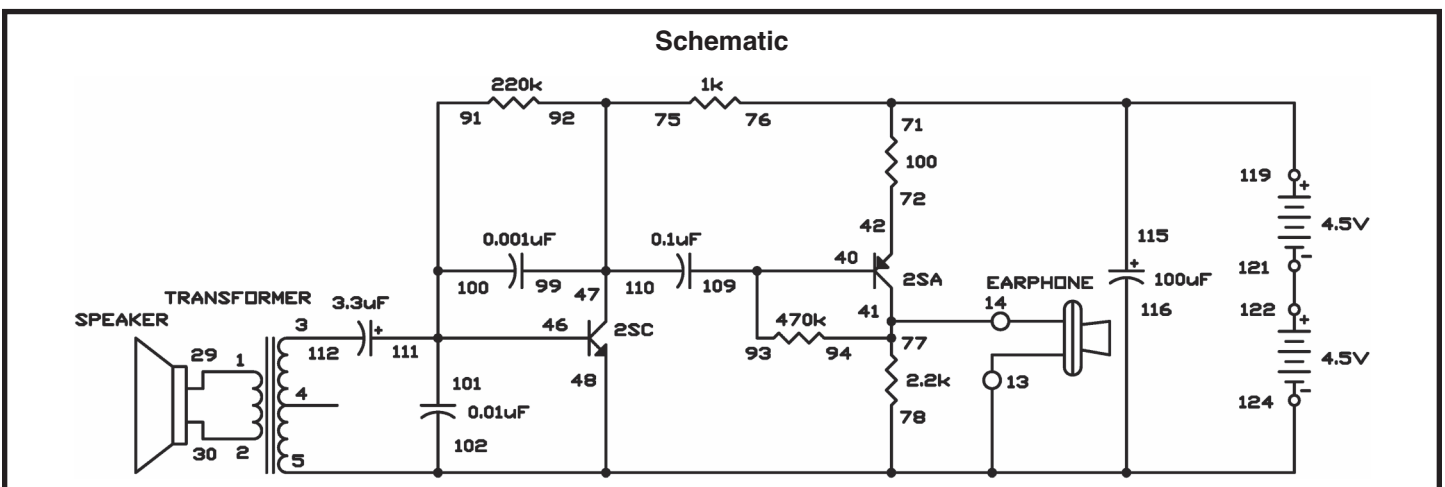

### **III. LED DISPLAY CIRCUITS**

## EXPERIMENT #23: LED DISPLAY BASICS

By using the LED display you will see the effect of electrical signals. An LED is similar to a normal diode except when current flows through it, it emits light. One example of the LED display is a power indicator on your DVD player or your radio that tells you the power is on.

A seven-segment LED display can show the numbers 0 through 9 for reading information on a calculator. Seven is the minimum number of segments (separate lines that can be each lighted) that are necessary to clearly distinguish all ten digits. Two conditions that you must always observe for the proper LED operation are:

1. Polarity correctness (+ and – LED connections)
2. Proper current flow

LEDs can burn out due to reverse polarity if the voltage is more than about 4 volts, or if the current is not limited to a safe value. When the polarity is reversed the LED will not light.

Series resistors (permanently wired to your kit) are used with the LED display to keep the current flow at a proper level. Current flows through these resistors and the LED to terminal 25, providing a comparatively constant voltage (approx. 1.7 volts) to the LED. To make the current flow through the LED display we need voltages above this value. The series resistors set how much current flows from the batteries through the LED.

Now it is time for you to learn about the common-cathode seven-segment LED digital display. Seven LED display segments use one contract point – terminal 25 – as a common negative electrode in a common- cathode.

To allow current to flow through an LED must have both (+) and (–) connections. The anode is the positive side and the cathode is the negative side. In this kit the LED display is a common cathode type. You connect any anode segment terminals as required, to the battery's positive side and connect the common cathode segment terminal (terminal 25) to the negative side of the battery.

LEDs operate tremendously fast. An LED can turn off and on hundreds of times per each second; so fast that you won't even see it blink. There is no warm up time or large amount of heat produced unlike an incandescent lamp.

Do the following experiment to experience how fast the LED operates.

1. Do not close the key but hook up the circuit.
2. Decrease the light in the room to a low level so that you are able to see the LED light emission easily.
3. Close the key but only for less than a second.

You will notice that the display goes quickly off and on. Hold the platform steady but glance quickly at the LED as you quickly tap the key. It will appear that the display goes on and off. What occurs in the persistence of the human eye is much longer than the LED's time but without the use of special instruments this gets the point across.

### Notes:

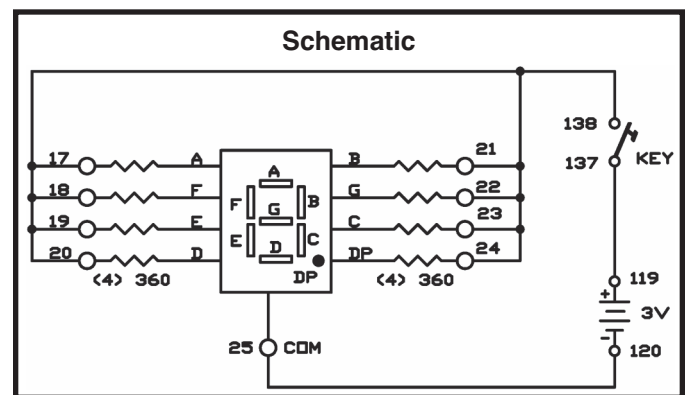

### Wiring Sequence:

- 17-18-19-20-21-22-23-24-138
- 25-120
- 119-137

## EXPERIMENT #24: DIGITAL DISPLAY CIRCUIT FOR THE SEVEN-SEGMENT LED

Wire the circuit as shown to connect the 3V supply to the LED segments and the decimal point (Dp). What numbers and letters do you see displayed?

In this experiment you can make some voltage measurements using a Voltage/Ohm Meter (VOM) if you have one. Connect the VOM as directed by its instructions. Skip these measurements if you do not have a VOM.

With this low battery voltage, you can reverse the polarity of the circuit by reversing the connections to the battery. (Changes to make are: change 25-120 and 119-WIRE, 25-119 and 120-WIRE.) Record your results. After you note your results, reconnect the battery with the correct polarity. Measure the LED voltages between terminal 25 and each separate terminal (17 through 24) using a VOM if you have one. Change the battery connections to 25-124, 121-122, and 119-WIRE to temporarily change the 9V supply. Next, make the same measurements. What amount is the LED voltage increased by, from using this three-time increase from the battery? (A normal increase is 0.25V)

Next, try measuring the voltage in each resistor attached to one of the LED segments. All of the resistors are  $360\Omega$ . The LED current is in milliamps (one-thousandths of an ampere) is calculated by dividing the voltage by  $360\Omega$ . The LED segment currents are approximately \_\_\_\_ milliamperes (mA) with the 3V supply (3mA typically), and \_\_\_\_ mA with the 9V supply.

Make a chart of the connections required to display 0 through 9 on the display in the space below.

### Notes:

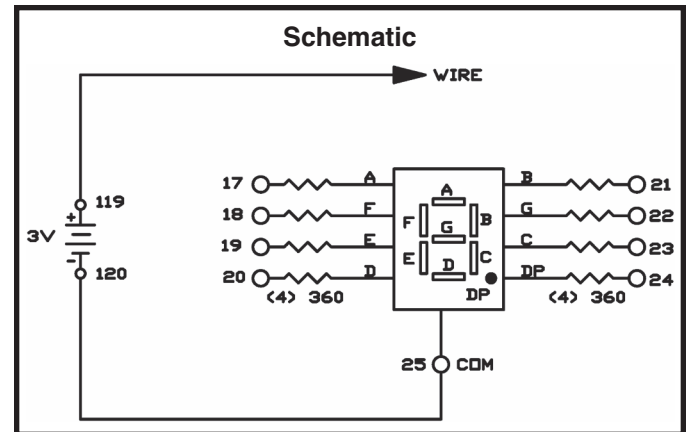

### Wiring Sequence:

- 25-120
- 119-WIRE

or

- 25-120
- 119-(17, 18, 19, 20, 21, 22, or 23)

## EXPERIMENT #25: LED DISPLAY WITH CdS AND TRANSISTOR

In this project you will see how to turn on an LED by using a transistor and a CdS cell.

### Notes:

Think of the CdS cell as a resistor that changes its resistance based upon the amount of light that falls upon it. In the dark the resistance is very high, around 5 megohms ( $M\Omega$ , 5 million ohms); in bright sunlight, it can decrease to about  $100\Omega$  or less.

To test this easily; just set your VOM to the resistance function and then connect it to the CdS cell. Now hold you hand over the CdS cell and note its resistance. Read the resistance again once you have moved your hand.

For a switch you can use the NPN transistor. This transistor turns on when sufficient positive voltage is applied to its base. Positive voltage leads from the positive terminal of the battery, then to the CdS cell, to the control, and then finally to the  $10k\Omega$  resistor. The amount of voltage applied to the transistor's base is determined by the total resistance value of the CdS, the control, and the  $10k\Omega$  resistor. The amount of light striking the cell and the control setting change the base voltage - making it either high or low enough to turn on the transistor. Using your voltmeter on the control, try to change the control position while casting a shadow over the CdS to verify the voltage change. When light changes over the CdS, adjust the control so that the transistor turns on and off.

Under bright light the circuit displays a 1. You can connect the wires to display any number you desire. 1 might be considered to be a binary digit, showing logic "high" (H or ON), as indication of the presence of a bright light on the CdS cell. Can you rewire this circuit to display another character to indicate this condition?

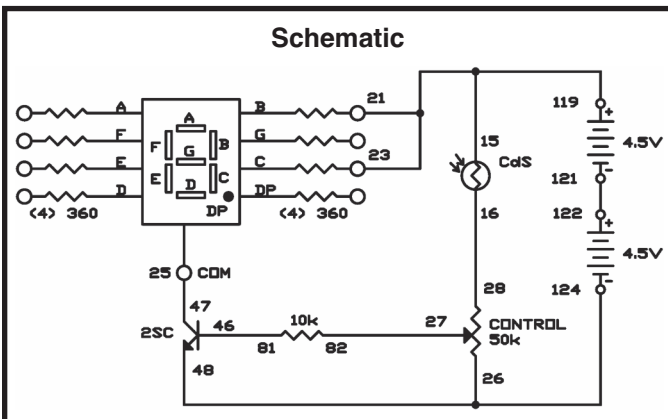

### Wiring Sequence:

- 15-21-23-119
- 16-28
- 25-47
- 124-26-48
- 27-82
- 46-81
- 121-122

## EXPERIMENT #26: SWITCHING THE LED DISPLAY USING TRANSISTOR CONTROL

This project shows how to control the LED display through the use of transistors.

This circuit is similar to the one in Project 18 (Transistor Action). The differences between these two are the position of the switch as well as the value of the resistor. In this project we use the base circuit of the NPN transistor as a switch, in order to control the cathode of the LED. Project 18 controlled the LED from the anode (positive side).

The transistors in this circuit act as switches. The PNP transistor is always on, allowing the current to flow from the collector to the emitter, because a sufficient amount of the negative voltage is applied to its base through one of the 10kΩ resistors. When you press the key the NPN transistor turns on, thereby applying sufficient positive voltage to its base, through the use of another 10kΩ resistor. When you close the key, then current can flow from the PNP's emitter to its collector.

Here are some important basic principles for you to remember:

- When negative voltage is applied to its base, a PNP transistor turns on; the current flows from the collector to the emitter.
- When positive voltage is applied to its base, a NPN transistor turns on; the current flows from the emitter to the collector.

Current can now flow through the NPN transistor, thus current can now travel a complete path - from the negative batteries side, to the NPN transistor, to the common cathode terminal of the display, to the PNP transistor, to the positive side of the batteries – thus lighting the display.

Turning on the LED with either of the transistors may not see important to you now. But, to people who design computer circuits that are complicated, it is an easy way to control the circuits.

Have you noticed that transistors switch on and off as fast as you press the key? These quick switching allows operations to be performed quickly by computers. Transistors are many times faster than hand operated switches or relays. Later you will see how to delay this fast switching by using other components.

Notes:

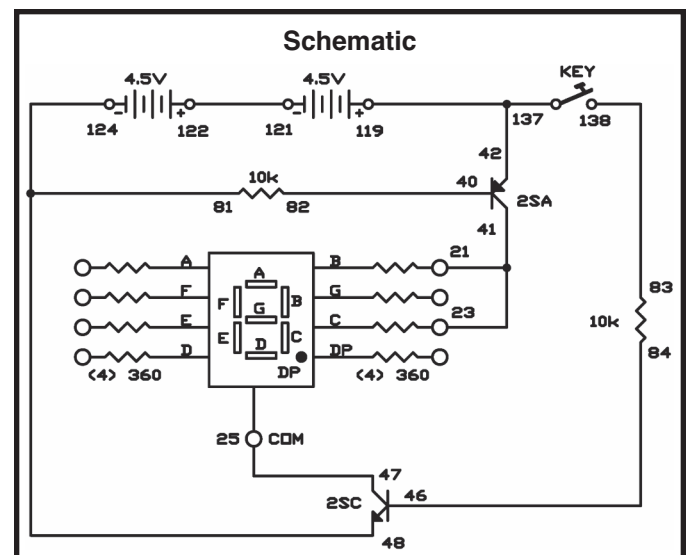

Wiring Sequence:

- 21-23-41
- 25-47
- 40-82
- 119-42-137
- 46-84
- 124-48-81
- 83-138
- 121-122



## **IV. WELCOME TO DIGITAL CIRCUITS**

## EXPERIMENT #27: “FLIP-FLOP” TRANSISTOR CIRCUIT

What is a flip-flop? It is a kind of circuit that changes back and forth between two states (on and off) at specific intervals. It flips into one state and flops into another and so on.

Two transistors, two capacitors and four resistors are used by the flip-flop to turn on and off the LED. Each of the transistors are always in the opposing state of each other; when transistor Q1 is on, transistor Q2 is off; when Q2 is on then Q1 is off. The change from on to off or off to on, happens quickly (in microseconds). Note the effect on the flashing rate of the LED when adjusting the control. To see how this circuit works, look at the schematic. Remember when voltage is applied to the base of a transistor, it turns on. On the negative side of the batteries you have the two PNP transistor connected through resistors. You may think that both transistors would always be on however, there are two capacitors connected to the bases that aid the cause of the flip-flop action.

In order to explain the circuit, you should assume that transistor Q1 is off. The 100µF capacitor will be charging and discharging through its base, so we can say that Q2 is on. Transistor Q2 is kept on after the 100µF capacitor has discharged due to the 47kΩ resistor and the control. Now the 10µF capacitor has received a charge and is discharging through the 4.7kΩ resistor, the battery and the Q2. (Remember that current can flow through the collector to the emitter when transistor Q2 when it is on.) As long as the charge on the 10µF is high enough the Q1 transistor remains off.

Transistor Q1 turns on when the charge drops to a specific point, the negative voltage from the 47kΩ resistor. Once Q1 turns on, and 100µF quickly starts charging and transistor Q2 turns off. With the Q2 off, its collector voltage rises toward the 9V of the battery supply and thus the LED turns off. The Q1 turns on fully through the fast charging of the 10µF. This flip occurs very fast.

The circuit will eventually flop back to the original state to repeat the above action due to the 100µF discharging through the Q2 transformer.

Look back at the previous projects and try to locate where you have used this sort of circuit.

### Notes:

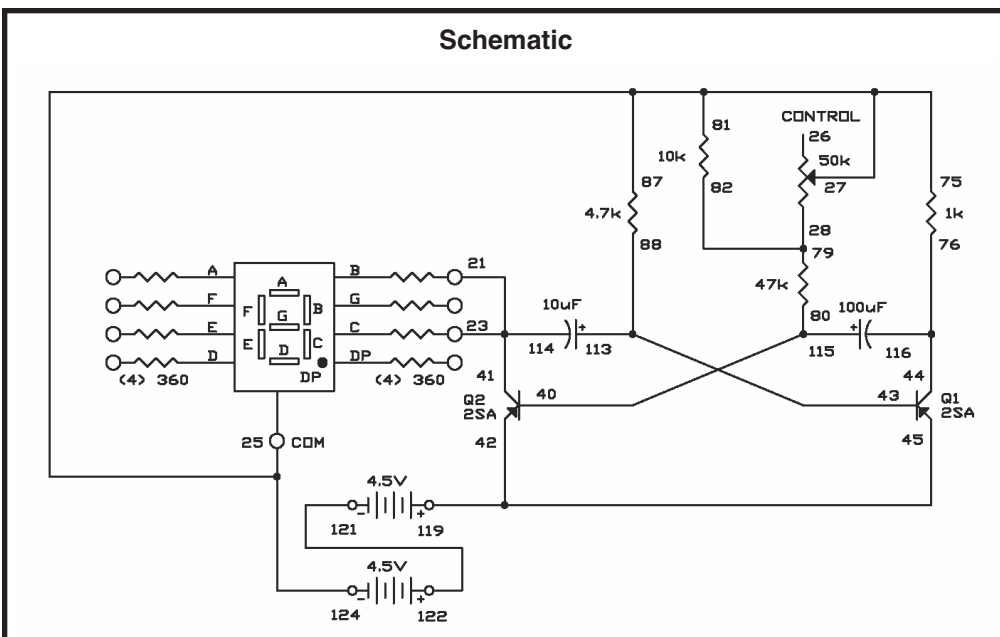

### Wiring Sequence:

- 21-23-41-114
- 75-81-87-25-27-124
- 28-79-82
- 40-115-80
- 45-42-119
- 43-88-113
- 44-116-76
- 121-122

## EXPERIMENT #28: “TOGGLE FLIP-FLOP” TRANSISTOR

Now it is time to step into the world of digital circuits and learn some basics. A circuit that acts as a switch to turn different components off and on is a digital circuit. In this section you will be dealing with diode-transistor logic (DTL) circuits- these are circuits that use diodes and transistors to turn the power on and off.

It doesn't usually matter how much voltage is applied to a digital circuit; what matters is whether the circuit is off (no voltage present) or on (presence of voltage). When a circuit is off we describe it as logic low or use the number 0. When a circuit is turned on we say logic high or use the number 1.

A switch that turns circuits on and off is a toggle switch. In this experiment we will use the flip-flop circuit to work as a toggle switch. In this project, unlike others that you will be doing later, the circuit does not change until you tell it to.

Once you have completed the wiring, set the switch to A. The lower part of the LED lights up. Press the key now. The upper section lights up while the lower section shuts down. Every time you press the key the LED sections will change, thus a flip and a flop.

When a transistor is on and the other transistor is off, it will stay either on or off until you tell it to change. We can easily say that a flip-flop circuit remembers. Once you put a circuit into a certain setting, it will stay that way until you tell it to change. Controlled by a single toggle signal, flip-flops can remember many things. This is also why computers can remember so many things.

### Notes:

#### Wiring Sequence:

- 84-108-44-17
- 81-106-41-20
- 25-124-137
- 40-107-83
- 42-45-130-110-72
- 43-105-82
- 71-75-111-131-129
- 76-109-112-138
- 119-132
- 121-122

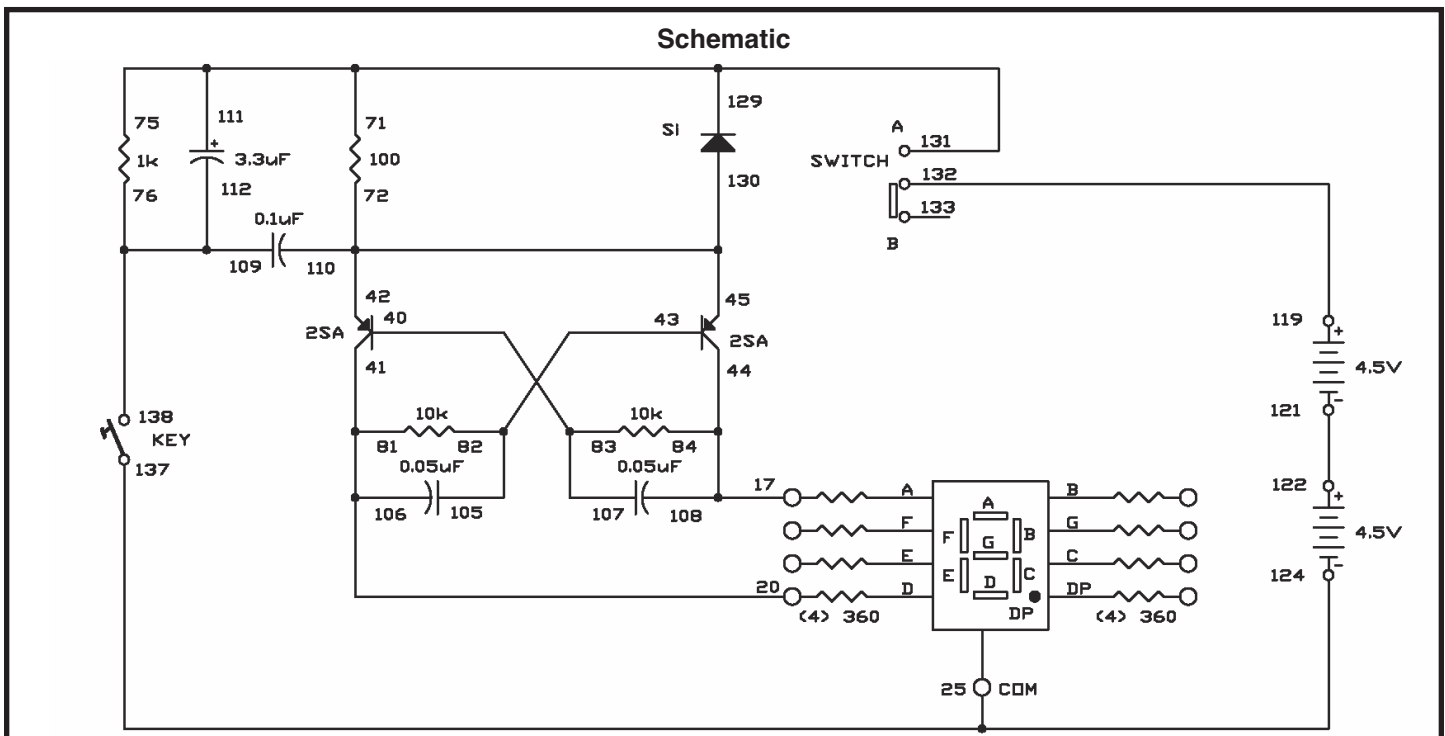

## EXPERIMENT #29: "AND" DIODE TRANSISTOR LOGIC WITH LED DISPLAY

In this circuit you will first learn about the AND circuit. When all the connections to its terminals are logic high (receiving voltage), the AND circuit produces a high output.

Make the connections in this circuit based upon the wiring sequence below. After that make the connection to terminals 119 and 124 using terminals A (126) and B (128) in different combinations to complete the circuit and to learn how an AND circuit works.

Terminal 124 provides logic high (voltage) while terminal 119 provides logic low (no voltage) in this circuit. H is only shown on the LED after you have connected terminal A and terminal B to terminal 124 (high terminal). If you make the connection of either terminal A or B or both to terminal 119 (low terminal) the LED will display nothing. For the combined output (the LED) to read H (high), both A and B have to be high.

The PNP transistor stays off when either or both of the inputs are low (terminals 126 and/or terminal 128 are connected to terminal 119), and when positive voltage is applied to the PNP transistor base through the diode(s). The NPN transistor is also off because the PNP transistor does not complete the circuit, and no current is supplied to the NPN transistor base. Also remaining off is the LED due to the fact that the common cathode terminal is not connected to the negative power supply.

The base of the PNP transistor turns on when both of the inputs are high and when both diodes supply negative voltage to the base of the PNP transistor. In addition, the NPN transistor turns on and then the current flows to the display to light the LED.

Symbol AB is used to represent an AND function that mathematicians use. On the bottom right of this schematic is the schematic symbol for the AND circuit.

### Notes:

### Wiring Sequence:

- 22-23-21-18-19-72
- 25-47
- 81-40-125-127
- 41-83
- 42-129
- 46-84-85
- 86-82-48-124
- 71-130-119
- 121-122
- 126-(to 119 "HIGH" or 124 "LOW")
- 128-(to 119 "HIGH" or 124 "LOW")

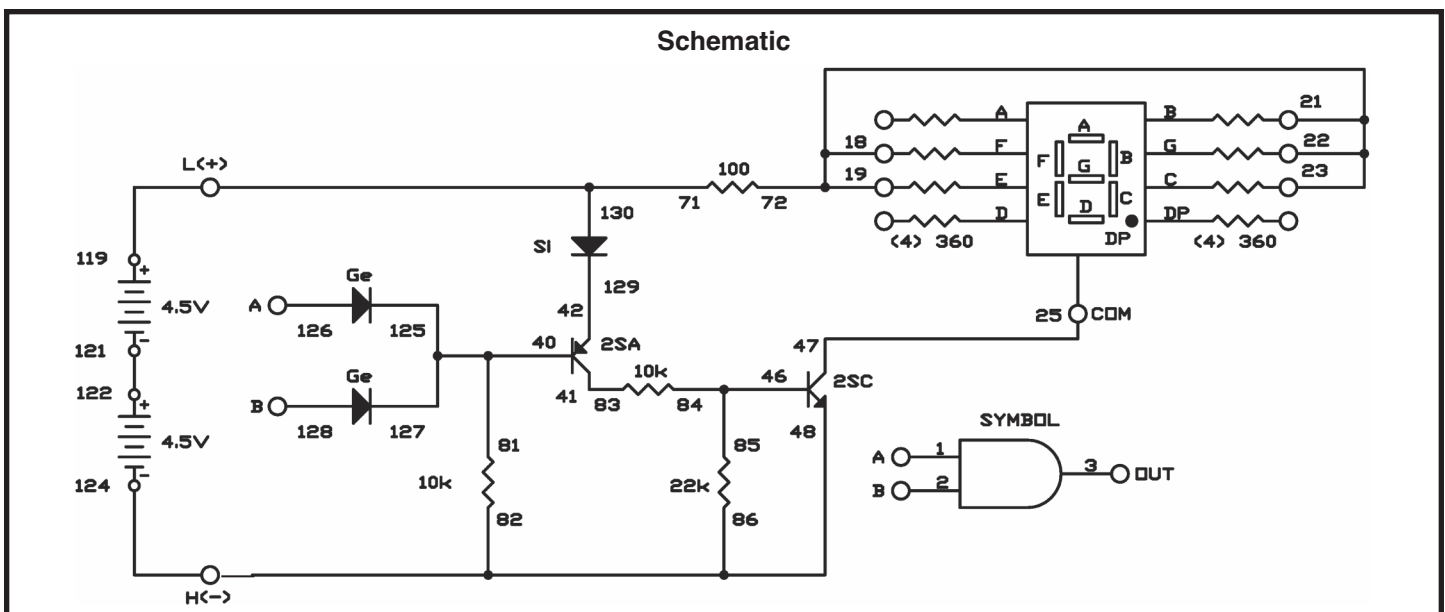

# EXPERIMENT #30: "OR" DTL CIRCUIT WITH DISPLAY

This next circuit is a logic OR circuit. Are you able to guess how this circuit may work? Remember that the AND circuit produces high logic only when inputs A and B are both high. In the OR circuit logic high is produced when A or B receives a logic high input.

notes of their similarities and their differences. On the schematics diagram see if you can follow the circuit.

**Notes:**

By connecting either terminal A or B to terminal 119 (logic high terminal) the display will show H. Try connecting each of the terminals to terminal 119; then to terminal 124. What occurs? When connected to H the output is high when either A or B is connected. A+B is the symbol for this logic function.

We won't explain the entire operation for you here because this circuit is similar to project #29. Compare these two projects (29 and 32); then make

**Wiring Sequence:**

- 71-41
- 72-19-18-21-22-23
- 79-25-48-124
- 81-47
- 83-127-125
- 84-80-46
- 85-42-119
- 86-82-40
- 121-122
- 126-(to 119 "HIGH" or 124 "LOW")
- 128-(to 119 "HIGH" or 124 "LOW")

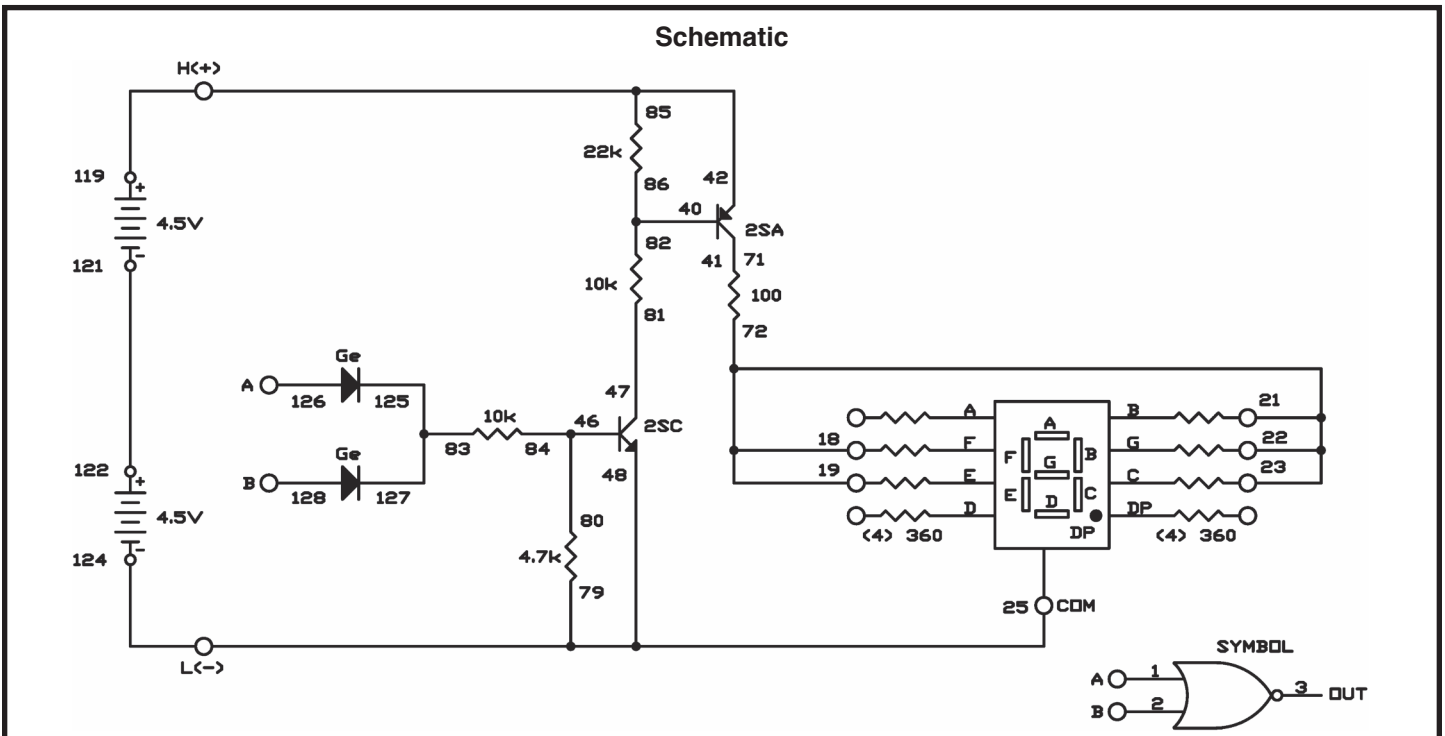

# EXPERIMENT #31: "NAND" DTL CIRCUIT WITH DISPLAY

You will not be able to find the word NAND in your dictionary (unless it is a computer or electronic dictionary). This term means inverted or Non-AND function. It creates output conditions that are the opposite of the AND circuits output conditions. When both inputs A and B are high the NAND output is low. If either or both of the inputs are low then the output is high. The symbol for logic looks like the AND symbol but with a small circle at the output.  $\overline{AB}$  is the representation of the function.

### Notes:

The NPN transistor stays off when either or both terminals A and B are connected to terminal 124 (logic low terminal), and negative current flows through the diode(s). The LED remains off. Both diodes allow positive voltage to flow through them when both of the inputs are connected to terminal 119 (logic high terminal). The NPN transistor is turned on by positive voltage, thus the current flows to light the L on the LED.

### Wiring Sequence:

- 81-20-19-18-119
- 25-47
- 82-46-128-126
- 48-130
- 121-122
- 124-129
- 125-(to 124 "LOW" or 119 "HIGH")
- 127-(to 124 "LOW" or 119 "HIGH")

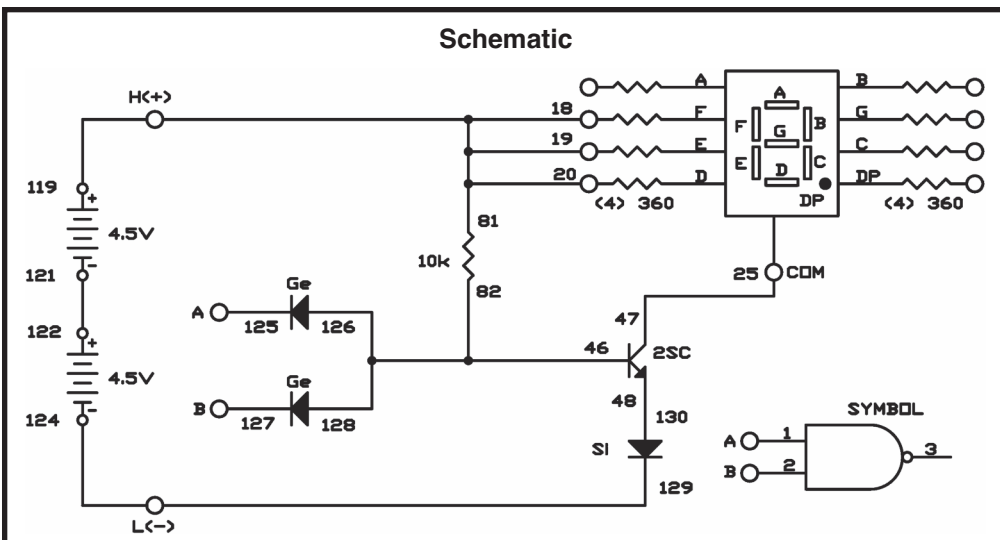

## EXPERIMENT #32: "NOR" TRANSISTOR CIRCUIT WITH DISPLAY

It is easy to determine what the NOR (inverted OR) circuit does now that you have built and learned about the NAND (inverted AND) circuit. When either terminal A or B is connected to terminal H (119) the display shows L. When low inputs are received by terminals both A and B then the circuit output is high. In the OR circuit this is the opposite. The schematic shows the logic symbol for the NOR circuit.  $A + B$  is the writing for the function. The OR is symbolized by the + and the bar over the symbol signifies that the circuit is inverted.

Notes:

The current path for the LED is complete when you connect either A or B (or both) to terminal H, turning the NPN transistor on. The transistor and the LED go off when you connect both A and B to L.

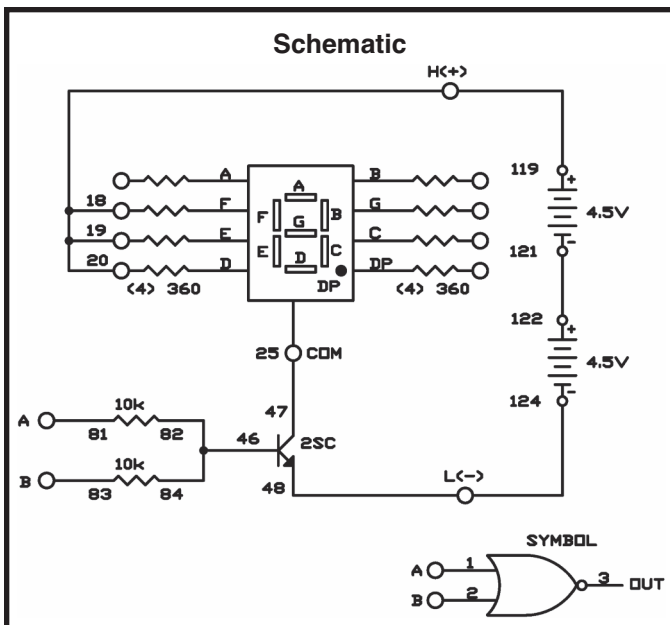

### Wiring Sequence:

- 18-19-20-119
- 25-47
- 46-82-84
- 48-124
- 81-(to 119 "HIGH" or 124 "LOW")
- 83-(to 119 "HIGH" or 124 "LOW")
- 121-122

## EXPERIMENT #33: “EXCLUSIVE OR” DTL CIRCUIT

If you don't know what an exclusive OR means, don't worry. An exclusive OR (abbreviated XOR) circuit provides a high output only when one or the other of its inputs are high.

You can see that an XOR circuit produces a low output, only if both of the inputs are the same (high or low). If the inputs are different (either high and low or low and high) it results in the output being high. This circuit is handy to let us know if we have two inputs that are the same or if the inputs are different.

Before completing this circuit, be sure you have the switch set to B. Once you have finished connecting the wiring, connect terminals 13 and 14 to turn the power on. Now watch LED 1. Press the key to produce a high input. Is there any change in the LED 1? To make both inputs low release the switch. To make the input through the switch high, set the switch to A. What does LED 1 do?

Press the key while leaving the switch at A to make both the inputs high. Now you can see that in an XOR circuit, you need two high inputs to produce a low output.

If desired, you can build an XNOR circuit (exclusive NOR). We will not build one here, however, you might be able to figure how to do it. Hint: It is almost identical to the NOR circuit followed by additional wiring in order to reverse the circuit. Make sure that you keep track of your experiments in your notebook, particularly if you make an XNOR circuit.

### Notes:

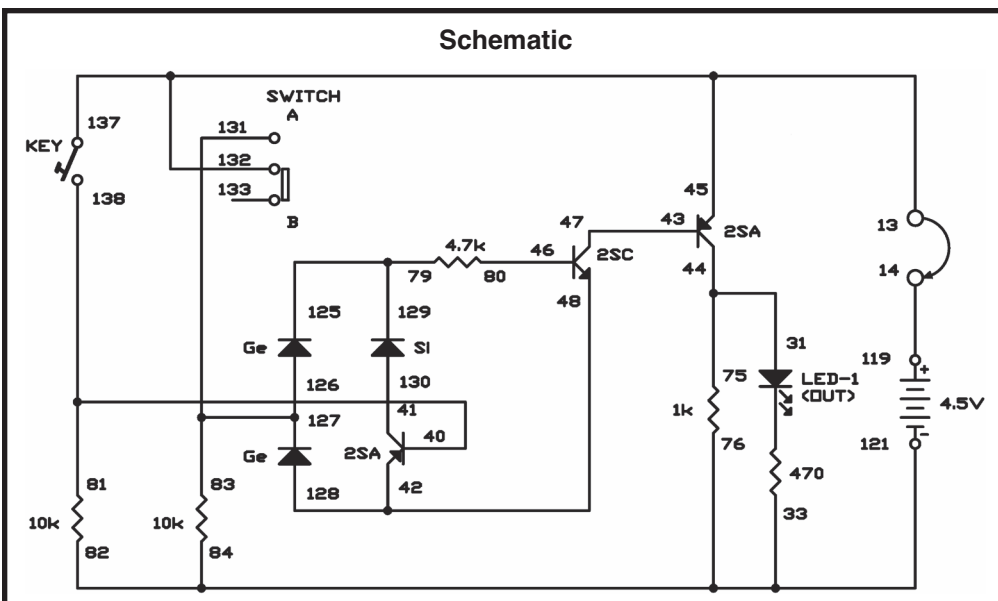

### Wiring Sequence:

- 13-45-132-137
- 14-119
- 44-31-75
- 76-84-82-33-121
- 81-40-138
- 41-130
- 48-42-128
- 43-47
- 46-80
- 79-129-125
- 83-126-127-131



## **V. MORE FUN WITH DIGITAL CIRCUITS**

## EXPERIMENT #34: "BUFFER" GATE USING TTL

Have you ever wondered what happens once you start adding digital circuits together, using the output of one as the input of another? You'll find out when you build this project.

A quad two-input NAND gate IC, is one of the integrated circuits contained in your kit. Some of these words will probably be a confusing at first. IC is short for integrated circuit. Something that contains many transistors, diodes, and resistors in one small package is an integrated circuit. This NAND gate uses TTL, short for Transistor-Transistor-Logic, because it is mostly constructed using transistors.

Quad means four. There are four separate NAND gate circuits, in this IC each receiving two inputs. Two input terminals are for Each NAND gate.

As you build this project make sure to consult to the schematic. This circuit takes the output from one NAND gate, and uses it for both inputs to the second (both inputs for the two NANDs are always the same here). What do you think happens if the input to the first NAND is 1, after learning about NANDs? If the first input is 0? Attempt to figure it out before building this project.

Set the switch to B before completing the wiring. To turn the power on, connect terminals 13 and 14. What happens to LED 1? Set the switch to A. LED 1 lights up.

1 is the input when the switch is set to A, and 0 is the input when the switch is at B. When the input to the first NAND is 1, its output is 0. But the 0 output of the first NAND is the input to the second. The 0 input to the second makes its output become 1, lighting the LED.

### Notes:

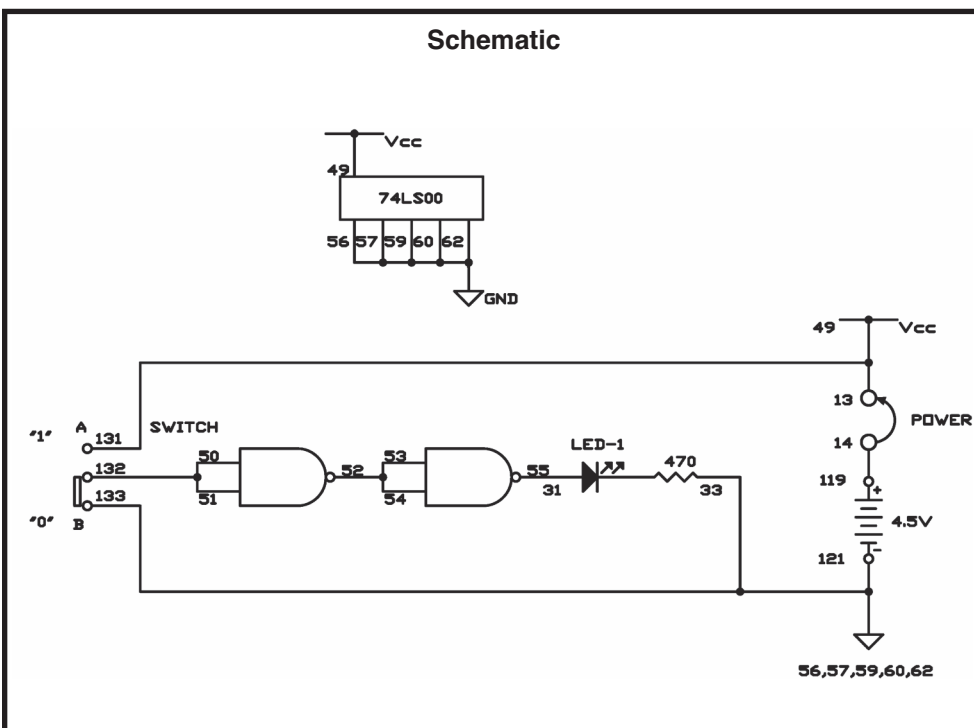

### Wiring Sequence:

- 13-49-131
- 14-119
- 31-55
- 33-56-57-59-60-62-133-121
- 50-51-132
- 52-53-54
- 13-14 (POWER)

## EXPERIMENT #35: "INVERTER" GATE USING TTL

A circuit that has an output that is the opposite of its input is called an inverter. If the output is 0, (low) then the input is 1 (high). If the output is 1, then the input is 0.

Before completing this project set the switch to A. Next, connect terminals 13 and 14. You'll observe that both LED 1 and LED 2 are off. Since the input is 1, the output has to be 0. When you set the switch to B, you will see both LEDs come on, indicating the input is 0.

You can see from the schematic that we use two of the four NAND gates in the IC. With the switch at A, both inputs to the two NANDs are 1. This means the outputs of both NANDs are 0 (and the LEDs go out). When the switch is set to B, the LEDs come back on because we no longer have all inputs at 1.

One extraordinary thing to think about is how big the RTL and DTL circuits were in earlier projects. Four of those circuits, Believe it or not, have been shrunk down to fit inside this tiny IC.

ICs can be very complex. Large-scale integration (LSI) is the process of putting several circuits inside just one IC. The microprocessors running computers and cell phones are very complex ICs.

### Notes:

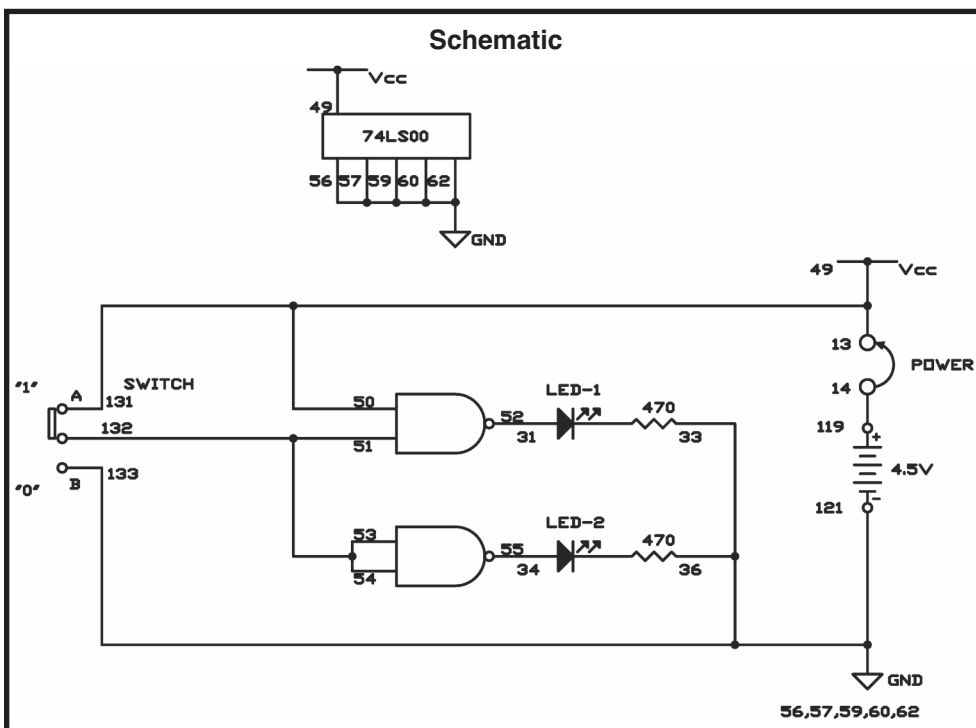

### Wiring Sequence:

- 13-49-50-131
- 14-119
- 31-52
- 36-33-56-57-59-60-62-133-121
- 34-55
- 51-53-54-132
- 13-14 (POWER)

## EXPERIMENT #36: “AND” GATE USING TTL

By using your kit’s NAND gates, are you able to figure out how to make an AND gate? To find out let’s experiment!

**Notes:**

As you build this circuit, leave the switch at B. connect terminals 13 and 14 to turn the power on once you have finished. Now press the key. What happens to LED 1? Now while pressing the key, set the switch to A. Are there any changes in LED 1?

As you can observe by setting the switch to A and then pressing the key, makes the inputs 1, causing the overall output to be 1. Are you able to flow the 1 input through the circuit until you reach a 1 output? Give it a try, but don’t peek at the answer.

Here is how it works – each 1 input goes into the first NAND gate. Thus causing the output of the NAND to be 0. This 0 output is used for both inputs to the second NAND. The LED lights when the 0 inputs to the second NAND cause its output to be 1. AND gate is formed from two NAND gates.

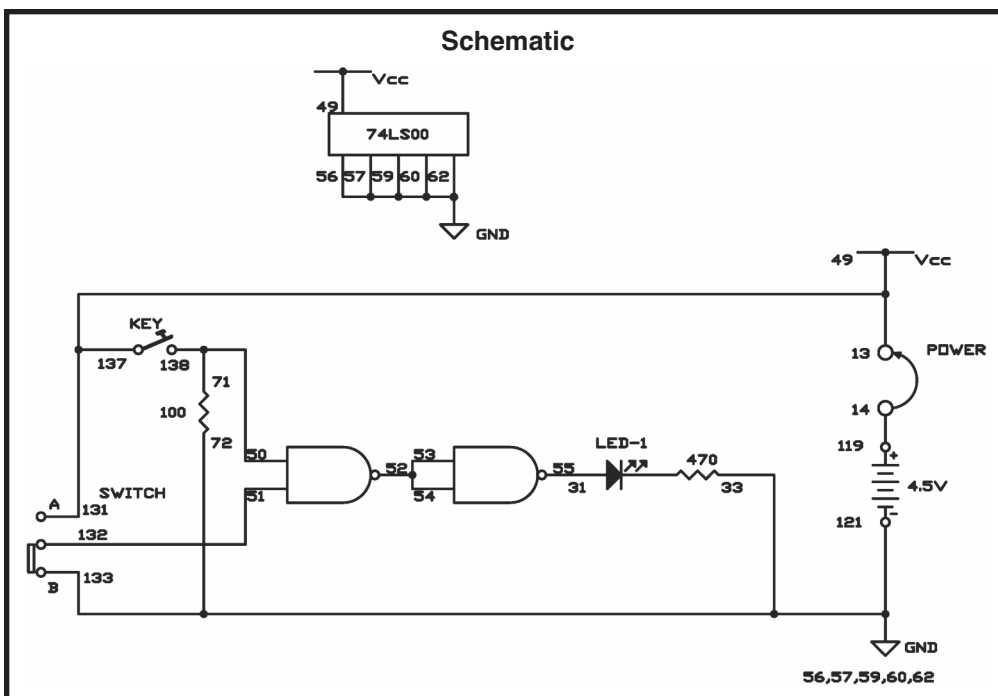

### Wiring Sequence:

- 13-49-131-137
- 14-119
- 31-55
- 72-56-57-59-60-62-33-133-121
- 50-71-138
- 51-132
- 52-53-54
- 13-14 (POWER)

## EXPERIMENT #37: "OR" GATE USING TTL

One of the cool things about the quad two-input NAND IC is that to make up other logic circuits all we have to do is combine the four NAND gates. In our last two projects you have been shown how you are able to use NANDs to make up some other logic circuits. In this project you will be shown how to make up an OR gate from the NAND gates.

Can you trace what happens from each input to the eventual output from just looking at the schematic? (Of course you can, just try it.)

Keep the switch set to B, as you work on this project. Connect terminals 13 and 14 when you've finished. Now press the key. What happens to LED 1? Set the switch to A and release the key. What happens to LED 1 now? Press the key again while keeping the switch at A and press the key again. Are there any changes in LED 1?

You see that this circuit acts like other OR gates you've experimented with. The output to the LED is 1 if at least one or the other of the inputs is 1. Have you tried tracing what happens from input to output yet? The explanation is in the next paragraph.

Say you press the key with the switch set to B. This enters 1 as both inputs of the NAND, thus causing the NAND's output to become 0. This 0 output is one of the inputs to the NAND gate controlling the LED. Since a NAND's output is 0 only if all inputs are 1, then the 0 input causes the NAND's output to go to 1, and LED 1 lights!

### Notes:

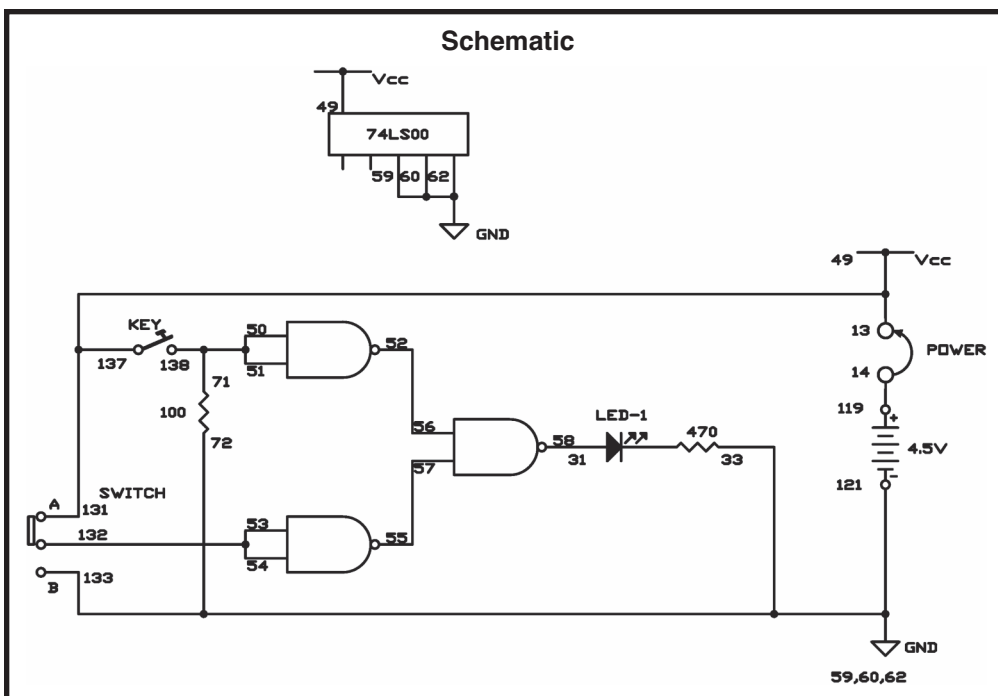

### Wiring Sequence:

- 13-49-131-137
- 14-119
- 31-58
- 72-59-60-62-33-133-121
- 50-51-71-138
- 52-56
- 53-54-132
- 55-57
- 13-14 (POWER)

## EXPERIMENT #38: "R-S FLIP-FLOP" USING TTL

R-S does not mean Radio Shack® flip-flop. As we mentioned earlier circuits that flip-flop alternate between two states. Those who use flip-flop circuits most often are engineers, and they use flip-flop circuits to switch between low (0) and high (1) outputs. We say a circuit is at set status (S) when the output is high or on. We use the word rest (R) when a circuit is off.

Once you have completed the wiring, to turn the power on turn the switch to A. LED 1 or LED 2 will light up. Touch terminals 13 and 14 in turn with the long wire connected to terminal 26. What occurs to LED 1 and LED 2?

The R-S flip-flop is set when the LED 2 lights. The R-S flip flop is in reset when the LED 1 lights. Set or reset the flip-flop, then remove the long wire from the circuit and see what it does.

Now you can observe one of the primary characteristics of the R-S flip flop. Once you have the circuit either set or reset, the circuit stays in the specific state until an input signal causes it to change. This means that R-S flip flop can remember things. Advanced computers use similar circuits to remember things.

### Notes:

### Wiring Sequence:

- 77-75-49-31-34-131
- 33-53-52
- 36-55-51
- 50-76-13 (SET)
- 54-78-14 (RESET)
- 121-62-60-59-57-56-LONG WIRE
- 119-132

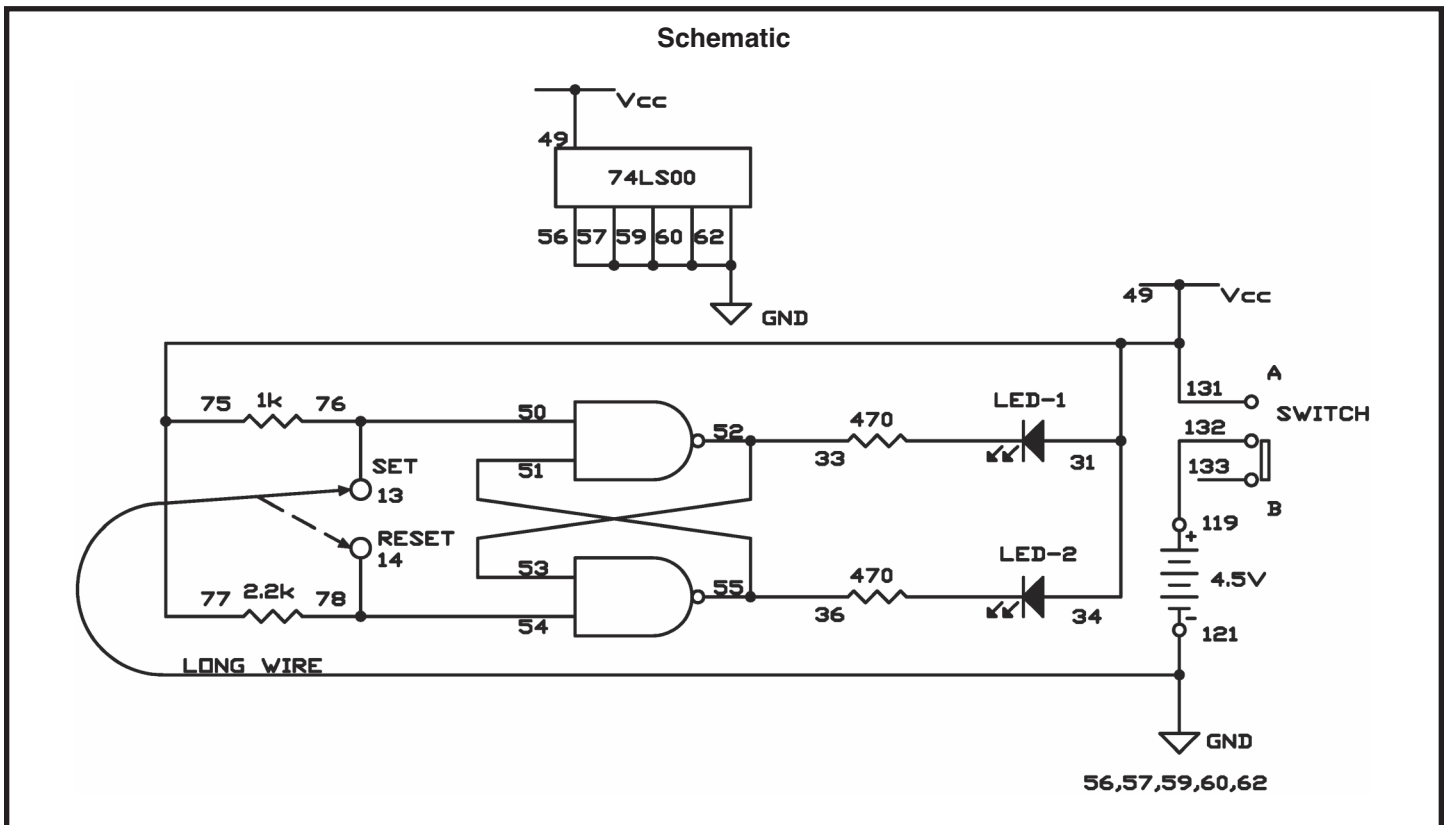

## EXPERIMENT #39: “TRIPLE-INPUT AND” GATE USING TTL

We have been using digital circuits that have two inputs, but that doesn't mean that we can't have more than the two inputs. Here is a TTL AND gate which has three inputs. Use the schematic to try and figure out how to have three inputs result in an output of 1.

We are going to do things a bit differently this time - terminals 13 and 14 create P as an input signal. When you connect the two terminals they create a 1 input, and disconnecting them creates a 0. Connecting terminals 119 and 137 “turns on” this project.

This circuit is called a gate because it is a circuit that has more than one input and only one output. The output of the gate is not energized until the inputs meet the certain requirements. We will be using this handy component in more digital circuits through other projects.

A gate circuit that is used to keep two portions of a circuit separated from each other is called a buffer. Next, look at the schematic and see if you can figure out the connections needed for the switch, the key, and terminals 13 and 14 that will result in an output of 1. Try to figure it out on your own and then read on to see if you were correct.

The circuit works this way: connected to the one NAND are both the key and the switch. When each provides an input of 1, then the NAND has an output of 0. This 0 creates the input of another NAND, causing the output to become 1.

This output of 1 then goes on to another NAND gate (can you find it on the schematic?). There it makes up one input in addition to the input from terminals 13 and 14 that created the other. Once these inputs are both 1, then the NAND's output goes to 0. This output is used with both of the inputs of the last NAND, thus causing it to become 1 and for the LED to light.

Doesn't it seem simple? Well, believe it or not but, even complex computers operate through the use of the same principles we are using in these circuits.

### Notes:

### Wiring Sequence:

- 13-49-131-137-119
- 14-73-57
- 31-61
- 74-71-62-33-121-133
- 50-72-138
- 51-132
- 52-53-54
- 55-56
- 58-59-60

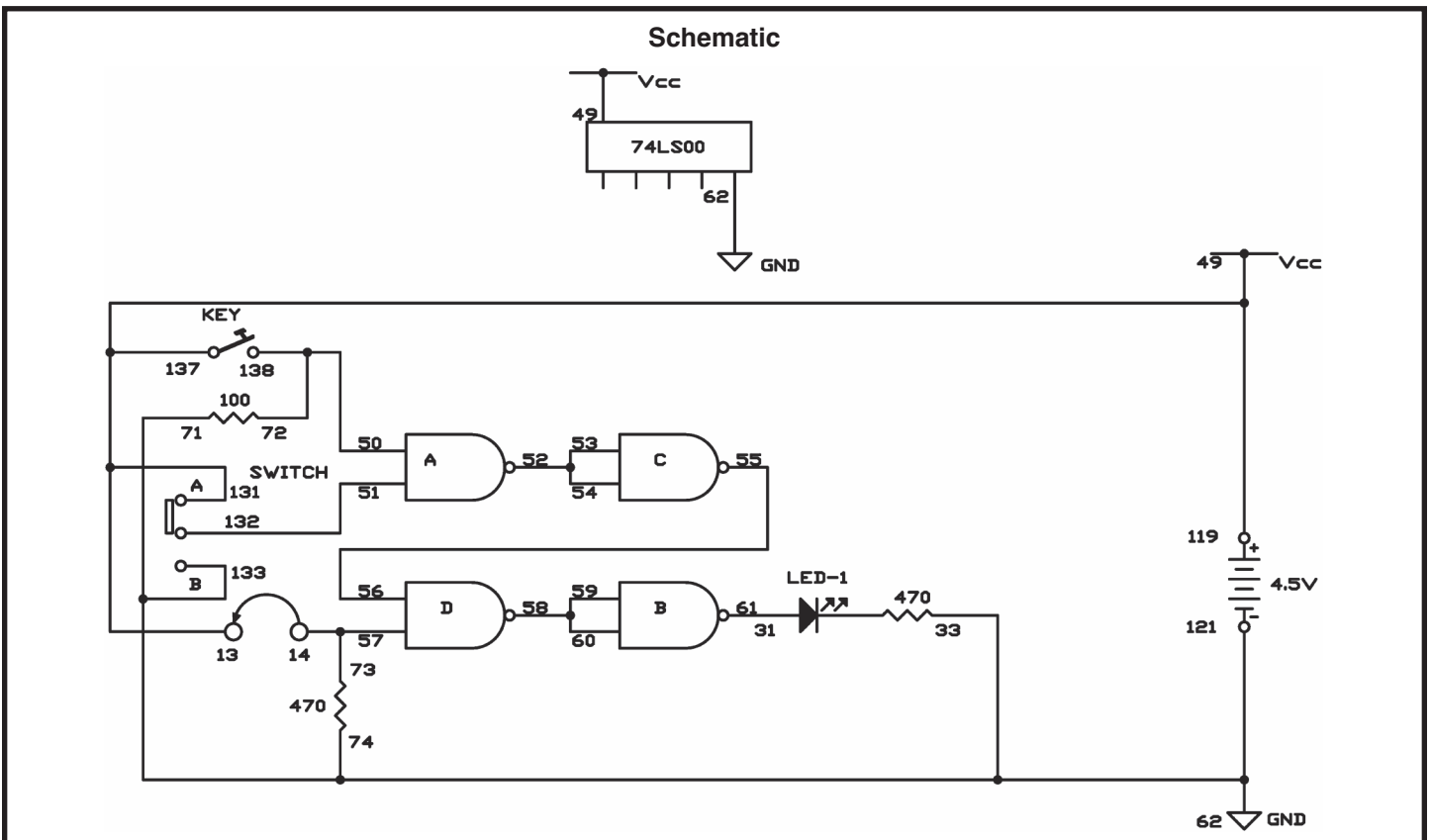

## EXPERIMENT #40: "AND" ENABLE CIRCUIT USING TTL

Setting the switch to B blocks the channel from the LED 1 to the LED 2. However, when you set the switch to A, you will find that LED lights and turns off at the same time as LED 1. The two NAND gates produce an AND gate.

Notes:

In this circuit the LED 1 is known as the data input. The output is the LED 2. Frequently these terms are used with enable circuits. They will show up from time to time when we talk about digital circuitry.

As you may have suspected by now, we can use digital circuits to perform enable functions. Are you able to figure out how? Make sure to keep the notes of your findings especially if you are able to figure out how to use an OR gate in an enable circuit.

### Wiring Sequence:

- 13-49-42-45-131
- 14-119
- 71-50-31-44-114
- 86-82-80-72-56-57-59-60-62-33-36-121-133
- 34-55
- 40-113-85
- 41-116-79
- 43-115-81
- 51-132
- 52-53-54
- 13-14 (POWER)

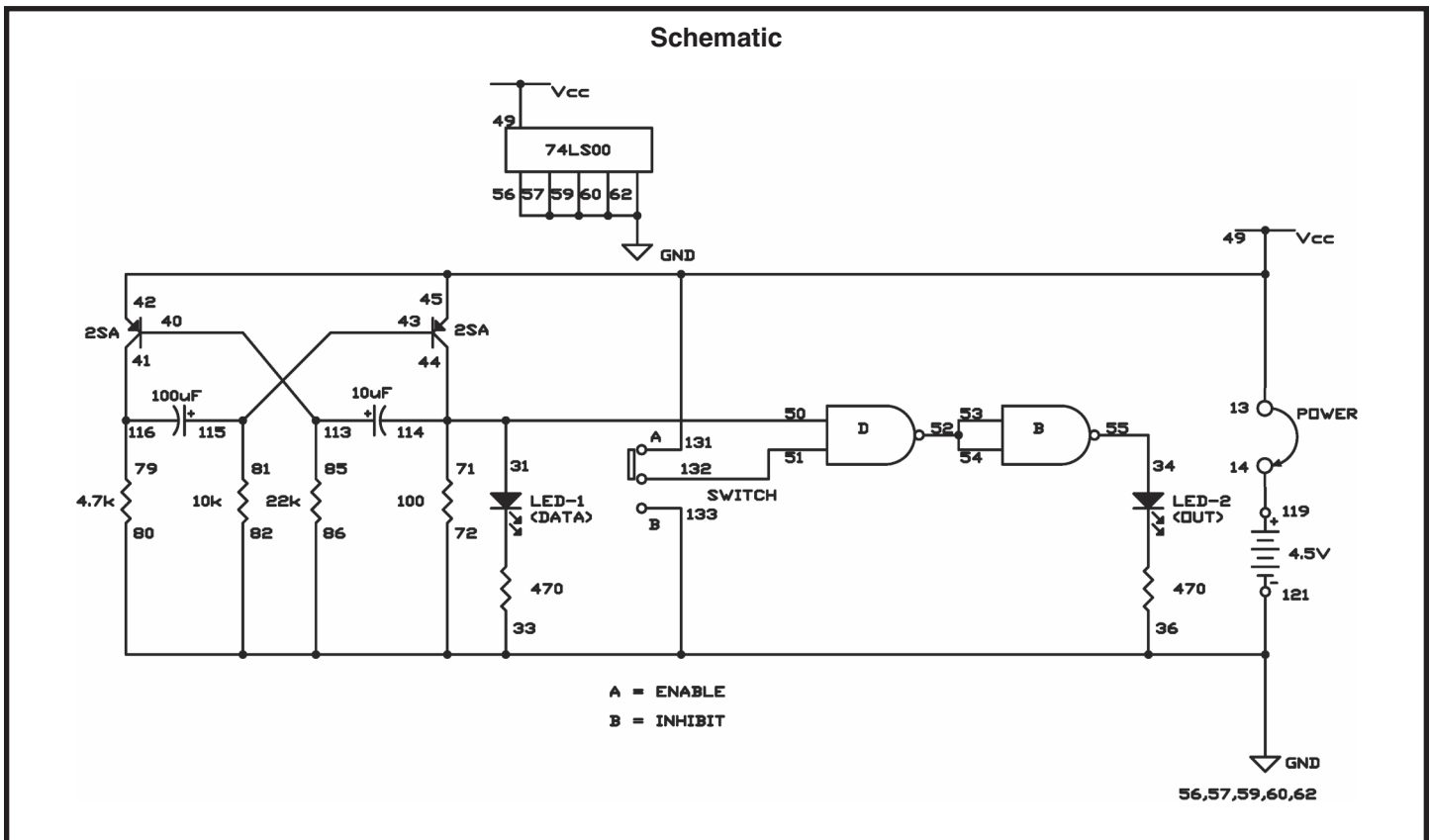



## EXPERIMENT #41: “NAND” ENABLE CIRCUIT USING TTL

NAND gates are able to act as electronic guardsmen. If you don't want a signal to be placed into input of a circuit, a NAND will make sure that it doesn't happen.

In the schematic, one thing that you recognize right away is the multivibrator. By watching the LED you can see the multivibrator. You will also realize that the multivibrator provides one of the inputs to the NAND gate. With the use of the schematic can you figure out what occurs when the switch is set to A? B? Are you able to figure out what occurs when LEDs 1 and 2 do with the switch set to A and then set to B? Make sure you that you make notes and then compare them with what you learn.

Set the switch to B, before completing the circuit. Once you have finished the wiring connect terminals 13 and 14 and then look at LEDs 1 and 2. You will notice that LED 1 will “blink” in order to indicate the output of the multivibrator. Look now at the LED 2. You will find that it is lighting continuously, thus indicating that something is preventing the LED signal at 1 from reaching the second LED. Set the switch to A and then look at LED 1. What is occurring? Is it the same occurrence that was happening to both LED 1 and LED 2?

As you can see, LED 1 and LED 2 are taking turns going on and off. This is because we make one of

the two inputs to the NAND equivalent to 1 once the switch is set to A. The multivibrator sends 0 and then signals to the other NAND input. When the output for the multivibrator is 1, then the LED 1 lights but only because both input signals to the NAND are 1, then the NAND output is 1 and the LED 2 lights. Now try to figure out what occurs when the switch is set to B – why does the LED 2 always light. Hint: B switch supplies an output of 0.

Now were you able to figure all of that out before you built the circuit? We sure hope so ☺

### Notes:

#### Wiring Sequence:

- 13-49-53-54-42-45-131
- 14-119
- 71-50-31-44-114
- 86-82-80-72-56-57-59-60-62-33-36-121-133
- 34-52
- 40-113-85
- 41-116-79
- 43-115-81
- 51-132
- 13-14 (POWER)

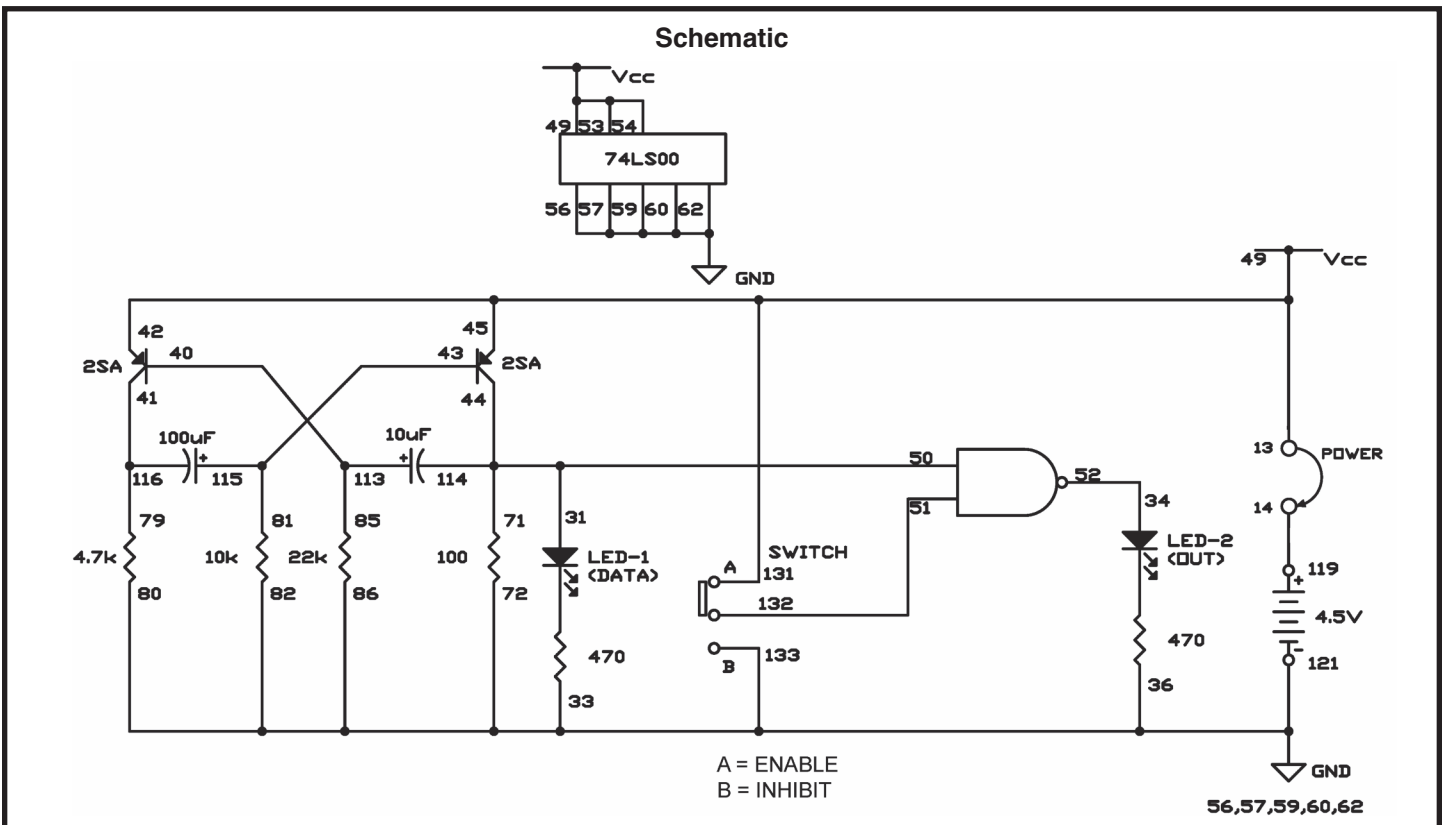

## EXPERIMENT #42: “NOR” GATE USING TTL

Try to mark 0 and 1 inputs on the schematic and see if this circuit comes up at either a 0 or 1 output. Give it try and don't peak at the answer.

### Notes:

As you are constructing this circuit, make sure to have the switch set to B. Once you have completed the wiring, connect to terminals 13 and 14. Now press the key. Are there any changes in LED 1? Now release the key and place the switch to A. Now what occurs on LED 1? Leave the switch at A and then press the key. Is anything different occurring?

This project acts just like the other NOR gates we have built. The NANDs mark with an A and B both have an input of 1. Therefore they both have an output of 0 when the input is 1. Their outputs are used as inputs to the NAND labeled C. The output of NAND C is 1 as long as one or both of inputs are 0. This output is used for the inputs of the next NAND causing it to have an output of 0. Therefore the LED 1 does not light.

A NOR gate only has an output of 1 when both inputs are 0. This occurs when the switch is set to B and the key is not pressed.

### Wiring Sequence:

- 13-49-131-137
- 14-119
- 31-55
- 72-33-62-133-121
- 50-58
- 51-61
- 52-53-54
- 56-57-71-138
- 59-60-132
- 13-14 (POWER)

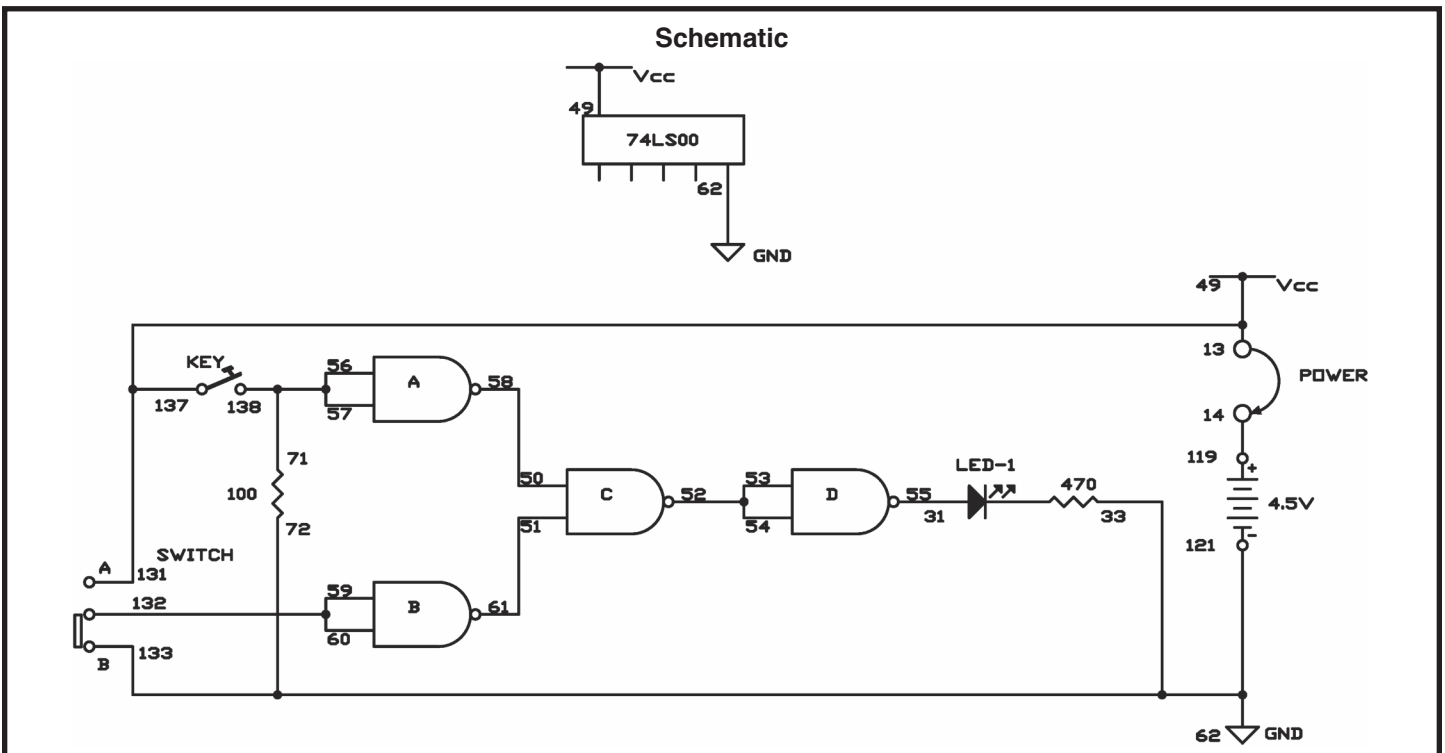

# EXPERIMENT #43: "NAND" GATE MAKING A TOGGLE FLIP-FLOP

If you are thinking that the NAND gate is a truly versatile circuit, well then your right! This experiment is a toggle flip-flop circuit made by using four NAND gates.

**Notes:**

When you have finished building this circuit, connect terminals 13 and 14 in order to turn the power on. Slowly press the key several times. You will notice that each time the key is pressed the LED 1 turns on. Now it is time to put on your thinking cap and try to trace what occurs from the key input to LED 1. Two out of the four NANDs function as a R-S flip-flop. See if you can figure out what the other NANDs are doing.

This circuit is known as inverter because it takes the inputs and reverses them.

**Wiring Sequence:**

- 13-75-85-81-49-31-42
- 14-119
- 33-57-61-87
- 40-88
- 41-74-77
- 46-102-86
- 47-53-50-76
- 78-62-48-112-116-137-121
- 51-55-60
- 52-56
- 73-54-115
- 58-59
- 82-101-111-138
- 13-14 (POWER)

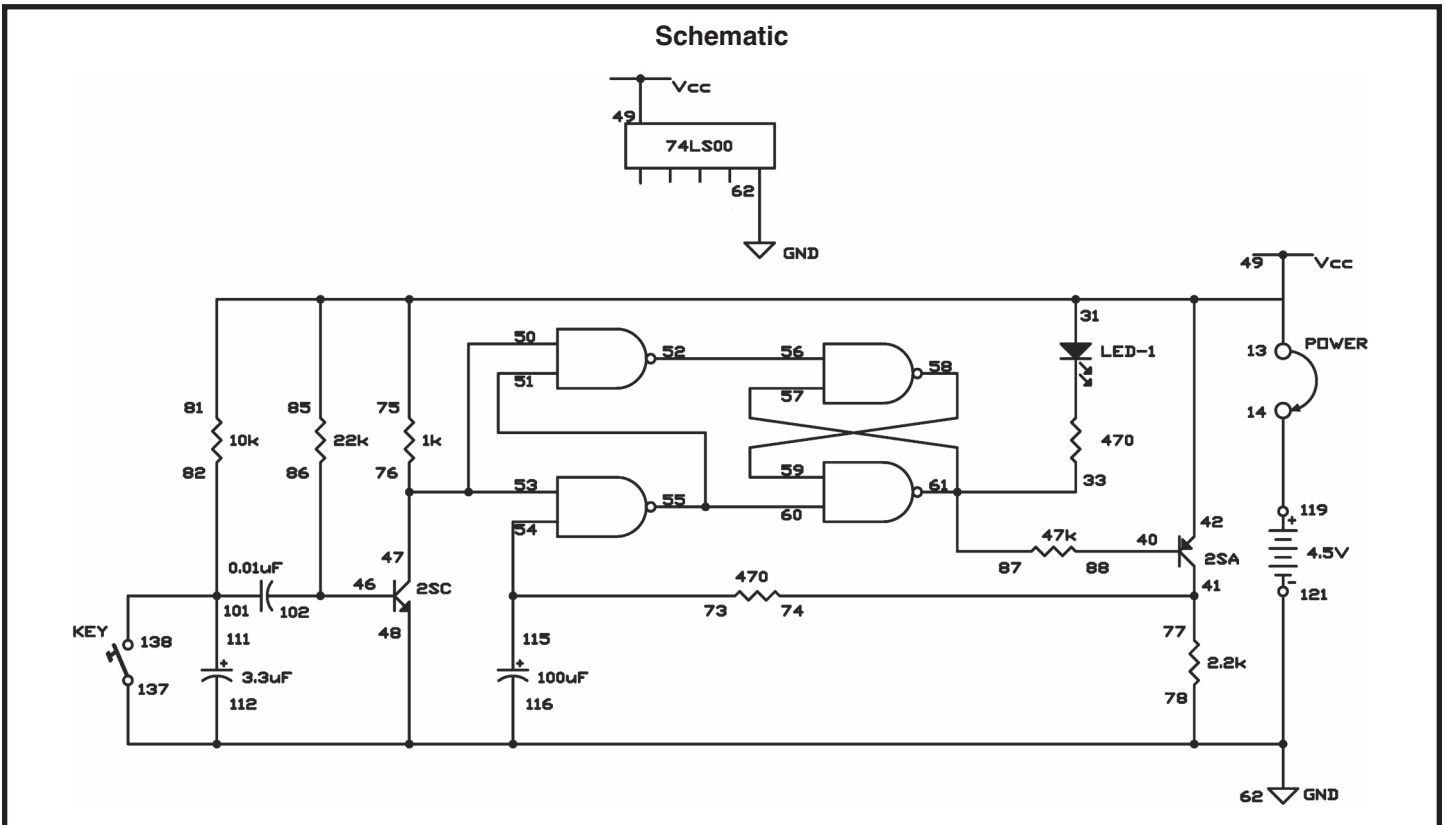

# EXPERIMENT #44: "EXCLUSIVE OR" GATE USING TTL

Since we have made up some digital circuits by combining NAND gates, it makes sense that we make XOR gates too. This circuit will show you how. Before you complete this circuit set the switch to B. Connect the terminals 13 and 14, once you have finished the wiring. Does anything happen to LED 1 when you press the key? Release the key now and set the switch to A. What occurs with the LED 1? Now press the key while leaving the switch at A. What happens with the LED 1 now?

### Notes:

As long as the inputs are different, output is 1. The output of the XOR gate is 0, as long as both of the inputs are the same - either 0 or 1.

Its thinking cap time again. Follow each 0 or 1 input throughout the circuit until they reach the output. It will help if you mark 0 or 1 on the input and the output of each NAND gate on the schematic.

### Wiring Sequence:

- 13-49-131-137
- 14-119
- 31-61
- 72-62-33-133-121
- 71-50-53-138
- 57-51-132
- 54-52-56
- 55-59
- 58-60
- 13-14 (POWER)

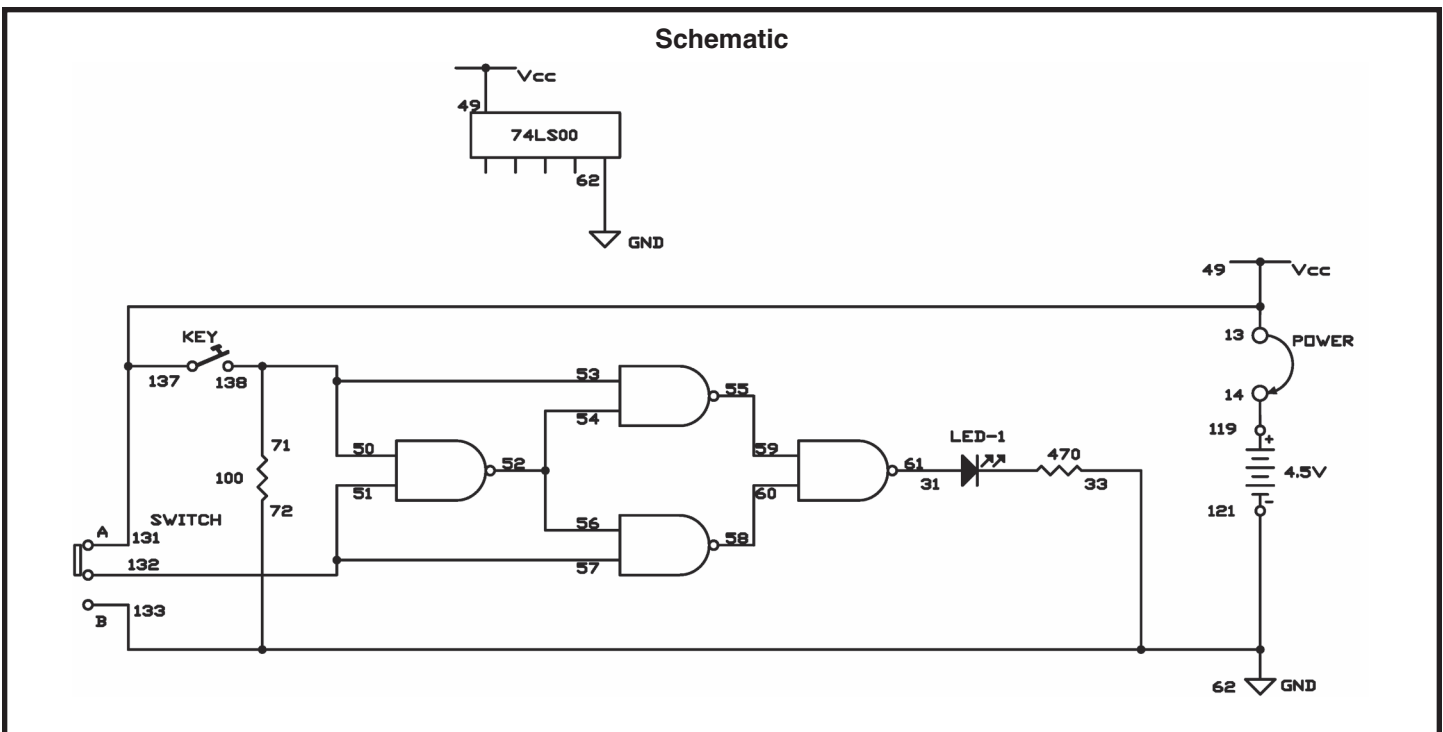

# EXPERIMENT #45: "OR" ENABLE CIRCUIT USING TTL

Have you figured out how to make an enable circuit using an OR gate? Well, if the answer is yes, then this is your chance to compare your design to our OR enable circuit.

**Notes:**

As done in projects 35 and 36, the multivibrator provides the input to the OR gate in this circuit. You can observe the output of the OR gate when you view LED 1—it flashes on and off corresponding to the output of the multivibrator. Can you tell what occurs when the multivibrator's input is applied to the OR gate by viewing the schematic? Give it a try before building the project.

Before completing this circuit, set the switch to A. Connect terminals 13 and 14 to turn the power on once you have finished the wiring. What does LED 1 do? What does LED 2 do? Set the switch to B. What occurs to LED 1 and LED 2 now?

We can simplify the circuit by stating that setting the switch to A blocks the flow of the data from LED 1 to LED 2. We call this inhibit status. An enable status occurs when the switch is at B; then data can flow from LED 1 to LED 2.

**Wiring Sequence:**

- 13-49-42-45-131
- 14-119
- 71-50-51-31-44-114
- 86-82-80-72-59-60-62-33-36-121-133
- 34-58
- 40-113-85
- 41-116-79
- 43-115-81
- 52-56
- 53-54-132
- 55-57
- 13-14 (POWER)

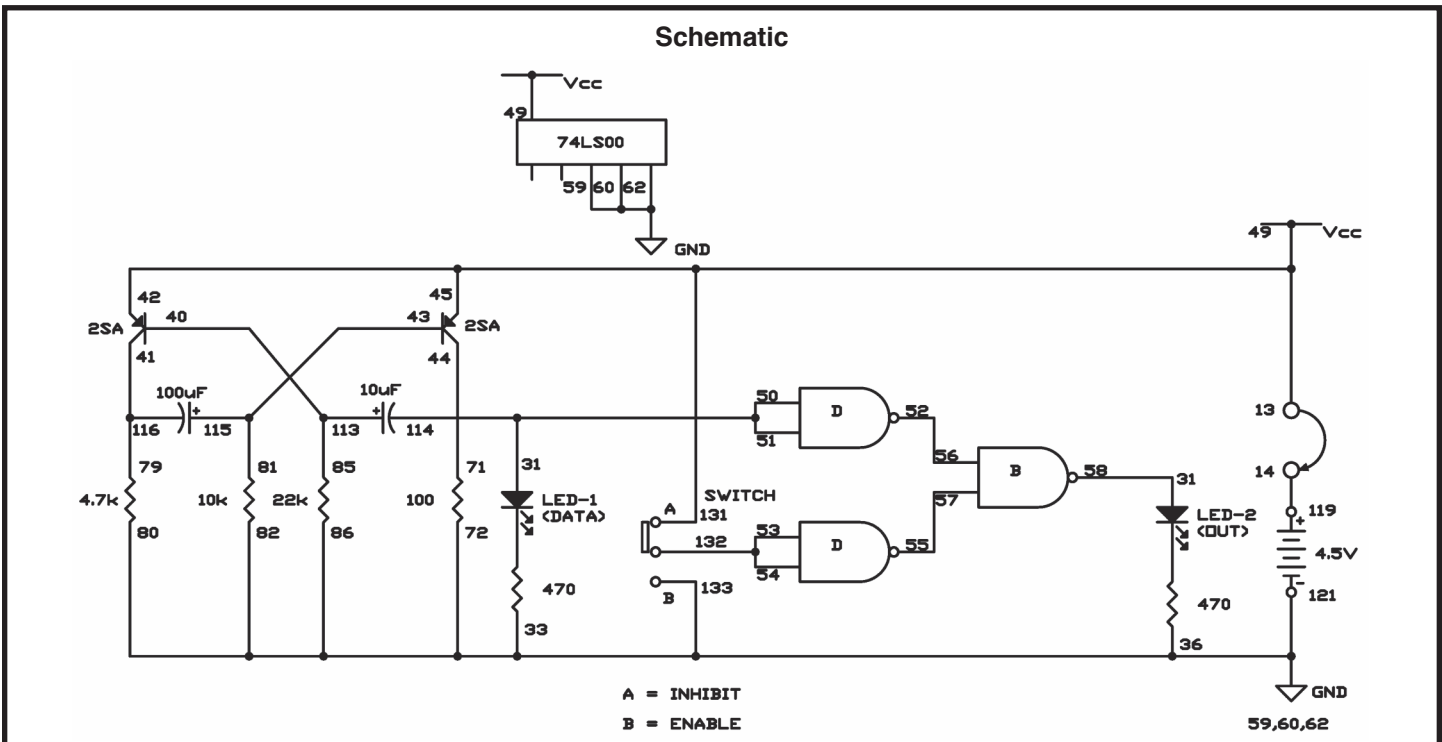

# EXPERIMENT #46: LINE SELECTOR USING TTL

It isn't hard to think of some situations where we might want to send input data to two or more different outputs. This experiment shows how we can use a network of NAND gates to help do that.

This circuit uses three NAND gates and a multivibrator. Build the circuit, connecting terminals 13 and 14 last. If the switch is set to A then LEDs 1 and 2 will be blinking; if the switch is set to B then LEDs 1 and 3 will be blinking.

Setting the switch to A or B controls the inputs to the two NANDs that light LED 2 and LED 3 as shown in the schematic. When the switch is A then the NAND is controlling LED 2 gets one steady input of 1. The other input is supplied by the output of the multivibrator. As the multivibrator output switches from 0 to 1, NAND controlling the LED 2 switches its output from 1 to 0.

When you have the switch set to B, the opposite happens. According to the input from the multivibrator LED 3 can go on and off because the NAND controlling the LED 3 gets a steady input of 1.

## Notes:

### Wiring Sequence:

- 13-49-34-37-42-45-131
- 14-119
- 71-57-54-31-44-114
- 86-82-80-72-59-60-62-33-121-133
- 36-55
- 39-58
- 40-113-85
- 41-116-79
- 43-115-81
- 50-51-53-132
- 52-56
- 13-14 (POWER)

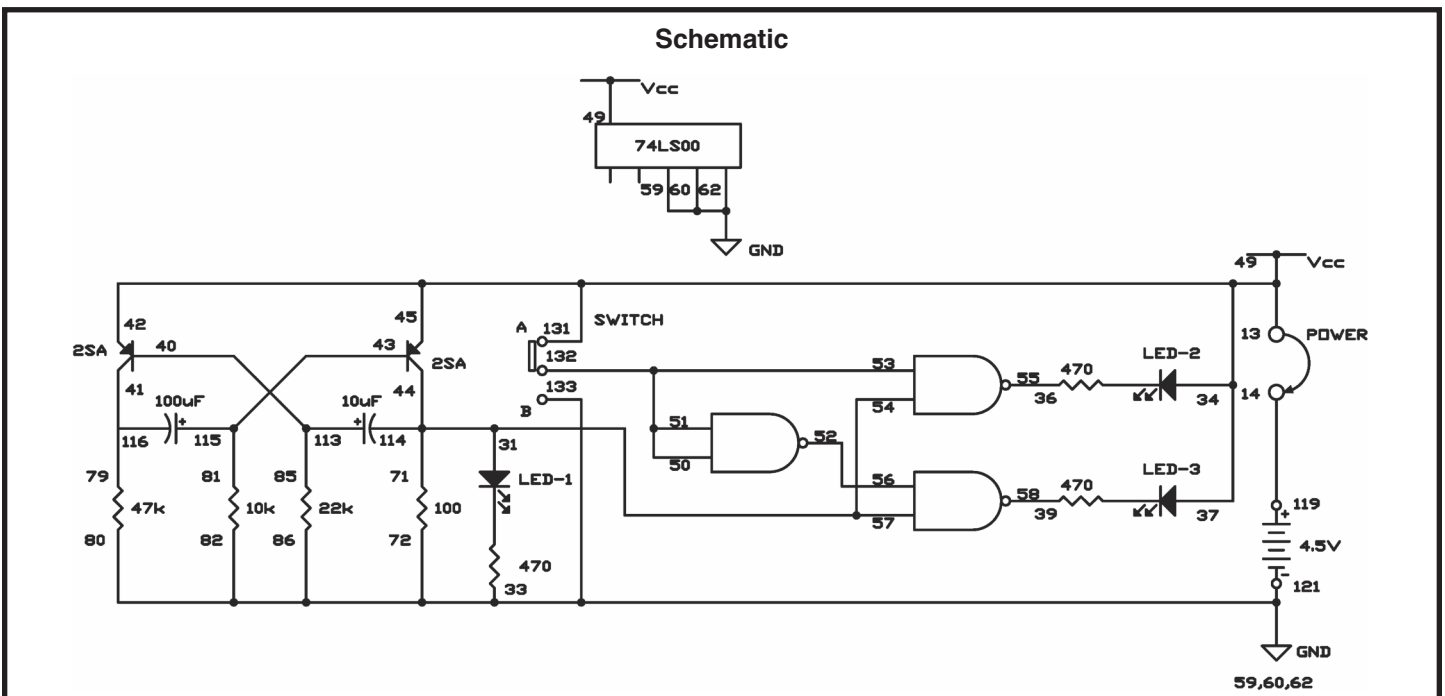

## EXPERIMENT #47: DATA SELECTOR USING TTL

The last experiment you did let you explore how data could be sent to two or more different outputs. You can probably think of situations where we might want to or need to do the opposite - which is sending data from two different sources of output. This circuit shows you how.

You see two different input sources when you view the schematic. The multivibrator circuit provides one of the input signals to LED 2; can you guess what the other signal is provided by?

YOU! You provide the input signal by pressing and relieving the key. The LED 1 is controlled by the action of the key.

Before completing this project set the switch to A. Once you have connected terminals 13 and 14 to switch on the power LED 2 blinks. Keep your eye on both LED 1 and LED 3. Has anything happened yet? See what happens to LED 1 and LED 3 when you press the key. At the same time as LED 1, LED 3 goes on and off. Set the switch to B. Now LED 3 turns on and off according to the blinking of LED 2. To determine the output of LED 3, you can use either of the two sources as the input.

Put on your thinking cap, and try following the inputs from the multivibrator, to the key, to the setting of the switch, to the LED. By each of the terminals of the NANDs, mark either a 1 or 0 to observe the different high and low inputs.

Computers use a more complex version of these circuits. As you probably guessed, the switching from one input channel to another is usually done electronically.

### Notes:

### Wiring Sequence:

- 13-49-42-45-131-137
- 14-119
- 73-50-31-138
- 86-82-74-72-80-62-33-36-39-121-133
- 71-57-34-44-114
- 37-61
- 40-113-85
- 41-116-79
- 51-53-54-132
- 43-115-81
- 52-59
- 55-56
- 58-60
- 13-14 (POWER)

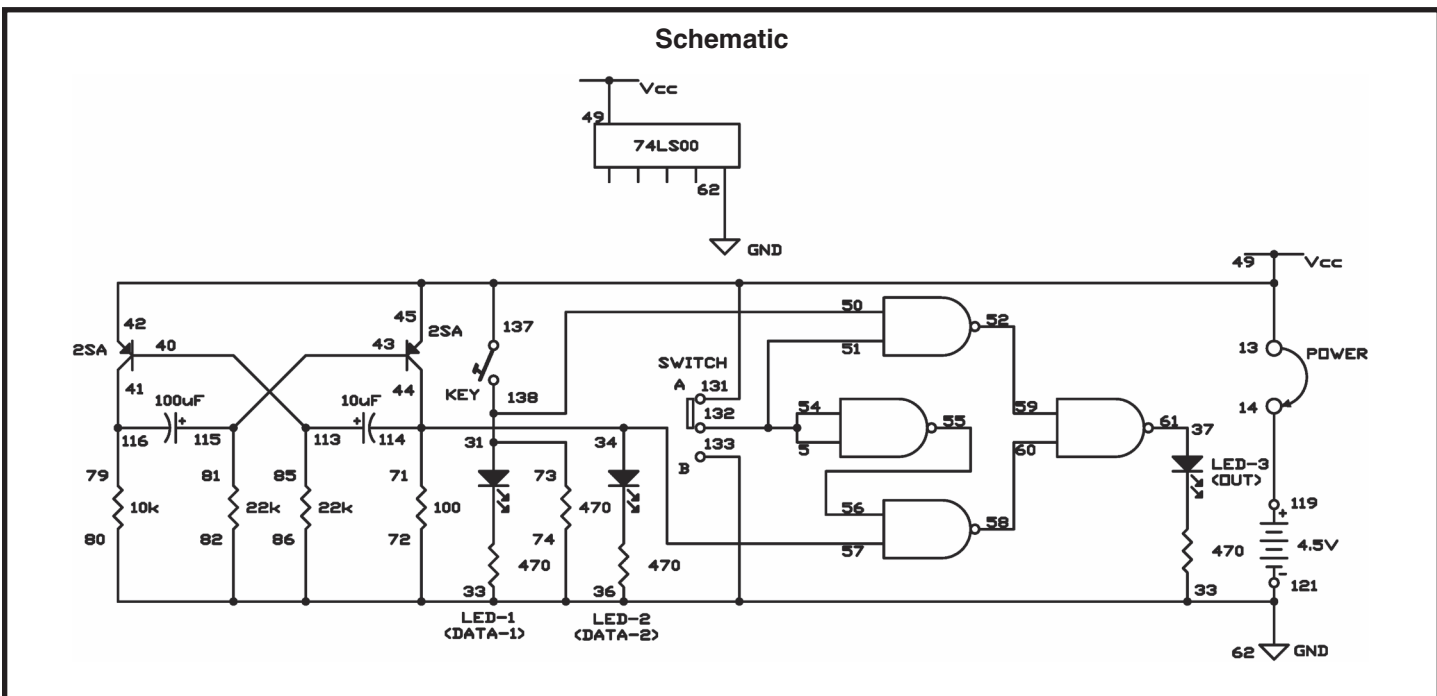

## **VI. MEET TRANSISTOR-TRANSISTOR LOGIC**



## EXPERIMENT #48: BLINKING LEDs

Connect terminals 13 and 14 to turn on the power and finish the wiring sequence for this circuit. You'll notice that both LED 1 and LED 2 alternate going on and off. By substituting different values for the 100 $\mu$ F capacitor you can change the speed of the blinking.

In place of transistor multivibrators, TTL multivibrators are becoming widely used today. Think of some reasons why? Make notes on any reasons you think TTL multivibrators would work better than regular transistor multivibrators.

TTL multivibrators use much less space than transistor multivibrators. TTL ICs also exert less current than comparative transistor arrangements.

### Notes:

#### Wiring Sequence:

- 13-49-31-34
- 14-119
- 33-60-59-58
- 36-61
- 50-51-77-115
- 52-53-54-78-75
- 55-57-56-76-116
- 62-121
- 13-14 (POWER)

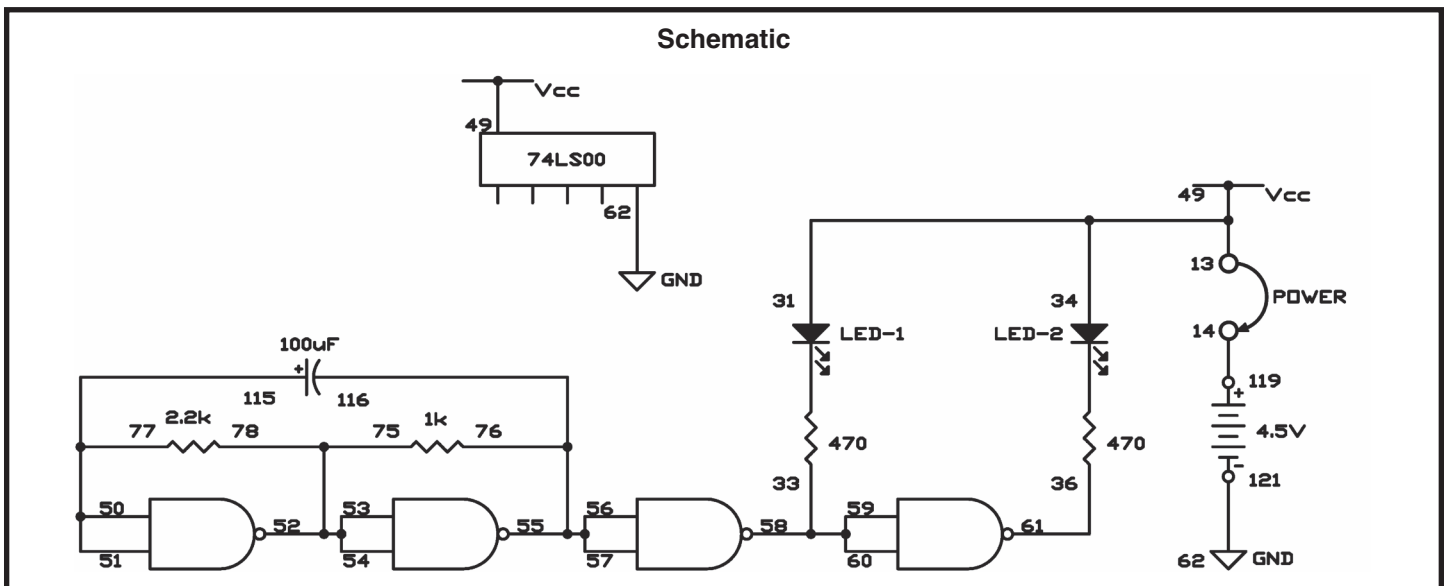

# EXPERIMENT #49: MACHINERY SOUND

Listen to the sound this project makes. Take your time and check your work because there are a lot of wiring steps. Once you've finished, set the switch to position A. What are you hearing? From looking at the schematic, can you explain how the circuit produces this sound?

This circuit has two multivibrators, one with PNP transistors, and one built with NAND gates. You have used both types before, but not together in the same circuit. The NAND gate multivibrator affects the operation of the transistor multivibrator, which sends its output through the NPN transistor to the audio amplifier. You hear the resulting sound from the speaker.

By substituting a different value for the 470µF capacitor, you can change the sound this circuit makes. See what happens when you try different values for the 10kΩ resistor and the 0.05µF capacitor.

### Notes:

### Wiring Sequence:

- 1-29
- 2-30
- 3-48
- 5-50-51-53-54-72-80-62-121
- 40-109-85
- 41-106-79
- 42-45-47-131-115-49
- 43-105-81
- 44-110-83-71
- 46-84
- 57-56-77-117
- 58-59-60-75-78
- 61-73-76-118
- 74-82-86-116
- 119-132

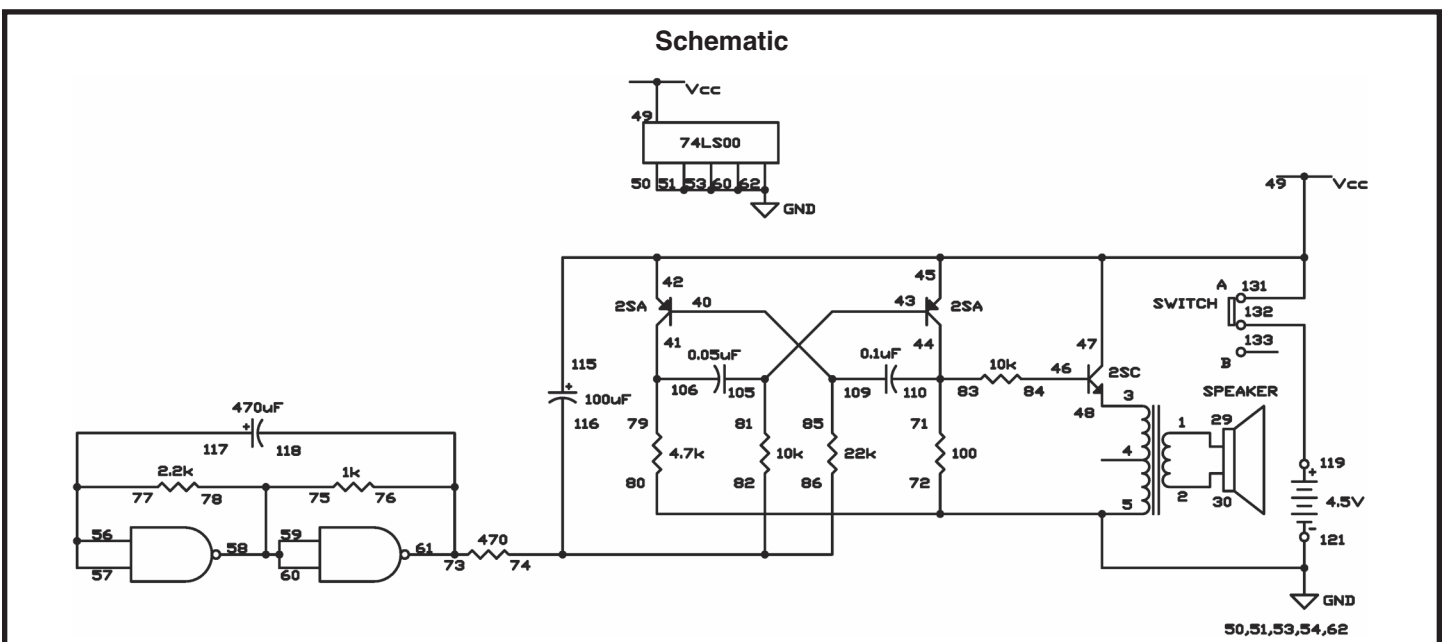

# EXPERIMENT #50: ASTABLE MULTIVIBRATOR USING TTL

multivibrator – are you able guess what astable means? Generate a guess, and complete this project to see if you were right.

To turn the circuit on, connect terminals 13 and 14. LED 1 begins to flash. Astable means the multivibrator’s output keeps switching back and forth between 0 and 1. So far most of the multivibrators that you have built do the same things.

You shouldn’t trouble figuring out how this particular circuit works. The 100µF capacitor is the key. In place of the 100µF capacitor, try using other electrolytic capacitors and see what result they have on LED 1 (Be sure to apply the correct polarity.)

By now can see why NAND gate ICs are so useful. Quad two-input NAND ICs, like the one in this set, are among the most widely used electronic components in the world, because there are so many different types of circuits that they can be used in.

**Notes:**

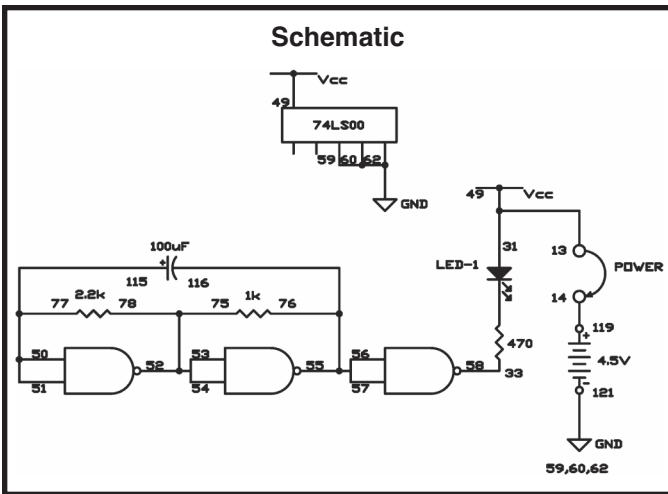

**Wiring Sequence:**

- 13-49-31
- 14-119
- 33-58
- 50-51-77-115
- 54-53-52-75-78
- 55-56-57-76-116
- 59-60-62-121
- 13-14 (POWER)

# EXPERIMENT #51: TONE GENERATOR USING TTL

We've been constructing tones with audio oscillators for so long that it might seem as if there's no other way to produce tones from electronic circuits. Multivibrators made from NAND gates do the job just as well.

Connect the earphone to terminals 13 and 14 and set the switch to A to turn on the power once you finish wiring this circuit. A tone produced from the multivibrator will be what you hear. Change the value of the capacitors from 0.1µF to 0.5µF. What effect does this have on the sound?

Try using different capacitors within this experiment. Don't try using any of the electrolytic capacitors, (terminals 111-118). To vary the tone, try to arrange the circuit so you can switch different value capacitors in and out of this circuit.

## Notes:

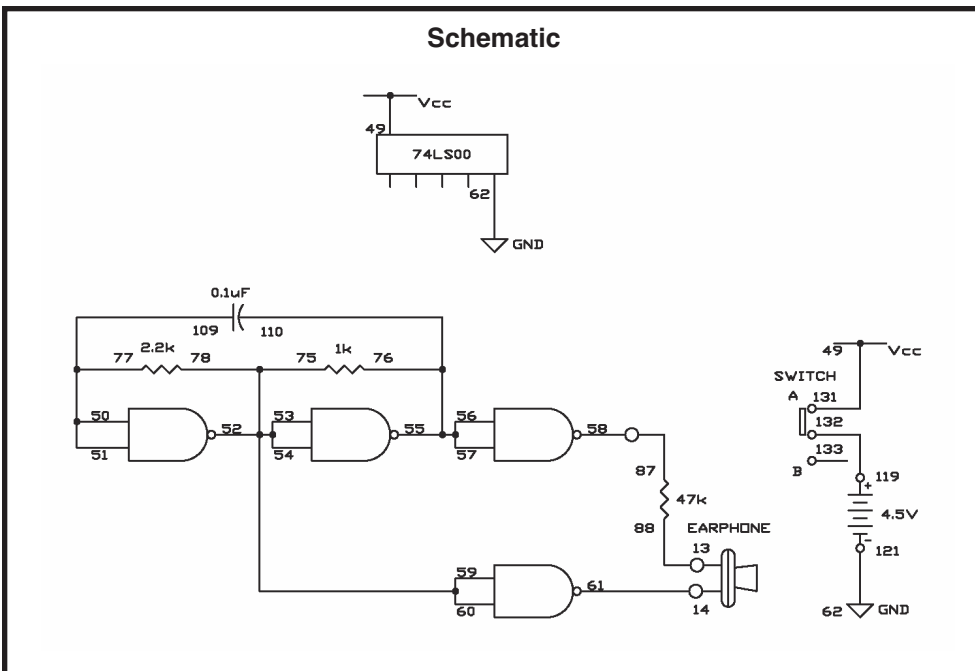

## Wiring Sequence:

- 49-131
- 50-51-77-109
- 52-53-54-60-59-75-78
- 55-57-56-76-110
- 62-121
- 119-132
- 58-87
- 88-13-EARPHONE
- 61-14-EARPHONE

# EXPERIMENT #52: MONSTER MOUTH

Do you know of someone who is a big mouth? (Or, have you ever been accused of being one?) This experiment lets you and your friends see who's got the most ear-splitting voice.

How does this work? When you yell, you create sound waves, which are actually variations in air pressure. These air pressure variations create pressure on the crystalline structure in the earphone. In a crystal structure, pressure creates voltage through a process called piezoelectricity. The voltage produced by the earphone is applied to a two-transistor circuit, which amplifies it. You can use the control to adjust the amount of the signal from the earphone that is amplified. Two NAND gates in series control the lighting of LED 1.

Set the switch position A and set the control to position 5. Watch LED 1 as you yell into the earphone; it probably lights. To make it more difficult to light LED 1, try turning the control counter-clockwise. (Try adjusting it just a tiny bit each time.) See how far you can lower the control to reduce the strength of the amplifier and still light the LED.

## Notes:

## Wiring Sequence:

- 27-79
- 28-110
- 124-131-31-49
- 33-55
- 41-43-100-81
- 42-72
- 44-109-99-83
- 45-88-78
- 46-80
- 47-115-51-50
- 52-53-54
- 77-71-123
- 119-132
- 40-87-13-EARPHONE
- 121-26-48-116-62-60-59-57-56-84-82-14-EARPHONE

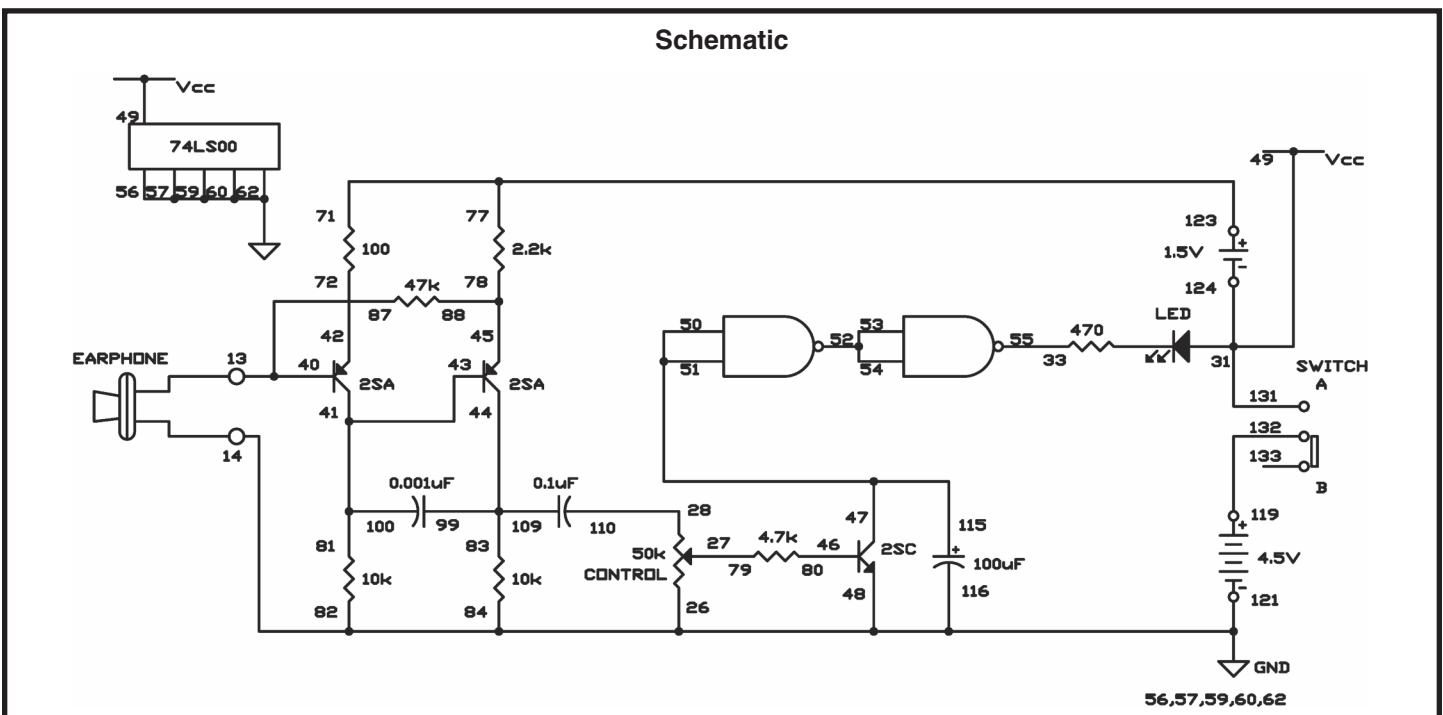

# EXPERIMENT #53: DARK SHOOTING

Think you have good night vision? This experiment is a game that lets you find out how well you can see in the dark. In a completely dark room, it tests your aim!

Once you have completed this project, put it in as dark of a room as possible. Slide the switch to position A and modify the control in a counter-clockwise direction until LED 1 and LED 3 light. Now it is time to test your ability.

For this game your “gun” is a typical flashlight. With a beam of light you use your flashlight to “shoot” the kit. If your aim is correct, you’ll hit the CdS cell to light LED 2 and turn off LED 1 and LED 3. Then turn off your flashlight and wait until LED 2 goes off before you try your next shot.

Start off trying to hit the CdS cell from around five feet or so. Your aim will improve as you increase your distance. Once you get really good, you can try hitting the CdS cell simply by switching your flashlight on and off rather than using a continuous stream of light.

You may have to modify the control knob very carefully to have LED 2 come on when light strikes the CdS cell. For the best results, use a sharply focused flashlight (not a fluorescent lamp or other light) and be sure you have the kit in a completely dark room. Once you’ve found the best setting, keep it there so you can use it again. Don’t change it until you want to stop using the “shot in the dark” game. Have fun and good luck ☺

## Notes:

### Wiring Sequence:

- 15-34-49-50-51-37-42-131
- 16-28
- 48-121-26-88-74-62-60-59-57-56-33
- 27-81
- 31-41
- 32-54-85
- 35-45
- 73-44
- 39-55-116
- 40-115-87
- 43-86
- 46-82
- 47-53
- 119-132

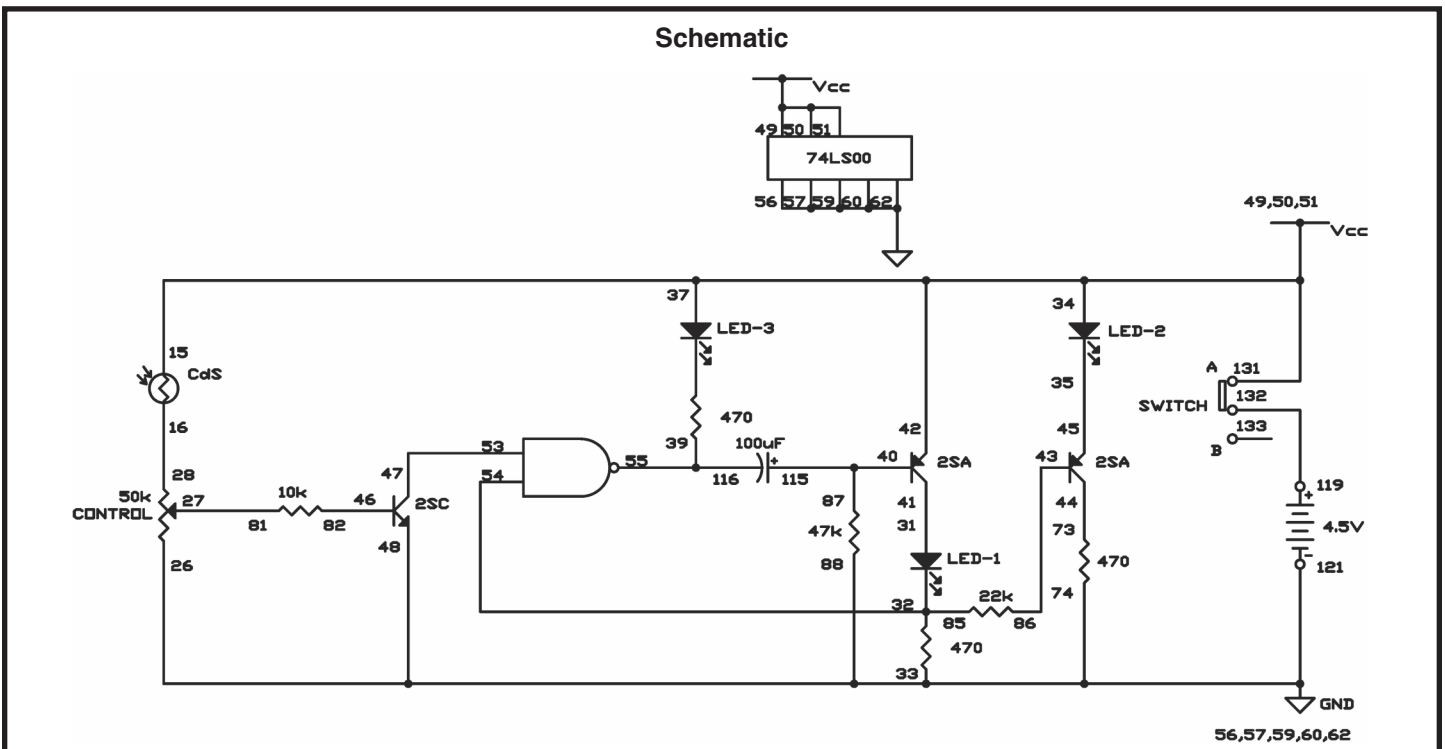

## EXPERIMENT #54: A ONE-SHOT TTL

What does “one-shot” mean to you?

Notes:

Turn the switch to A, and see what happens to LED 1 when you press the key once at a time. Try holding the key down for different periods while watching LED 1. Does LED 1 stay on the same length of time or does it change?

Regardless of the length of the input, you see that a one-shot multivibrator has an output for a certain length of time. (It “fires one shot.”) This means that it can be applied in many circuits as a timer. This circuit is also called a monostable multivibrator.

### Wiring Sequence:

- 81-75-49-53-31-131
- 33-58
- 50-55
- 51-82-83-109
- 52-56-57-115
- 54-77-116
- 59-60-62-78-84-138-121
- 76-110-137
- 119-132

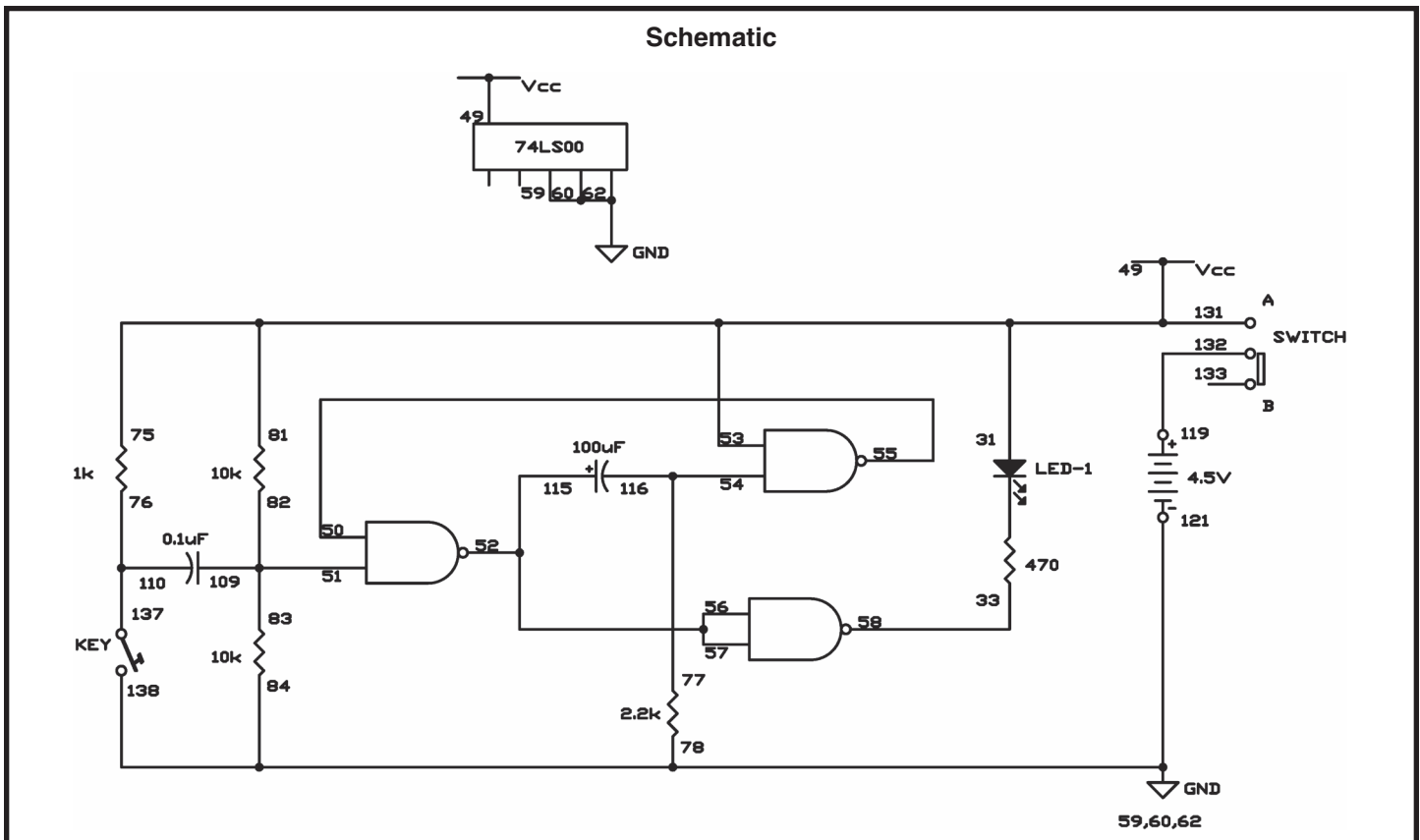

# EXPERIMENT #55: TRANSISTOR TIMER USING TTL

This is another type of one-shot circuit; in this project you hear the effects of the multivibrator. From the schematic you can see that this experiment uses a combination of simple components and digital electronics. Once you press the key, the 100µF capacitor is charged and lets the NPN transistor in the left corner of the schematic operate. You can observe that the collector of this transistor serves as both inputs for the first NAND gate.

The digital portion in the middle controls the PNP transistor on the right side of the schematic. To turn the power on, set the switch to A. You hear a sound from the speaker when the output of the first NAND gate is 1, and the multivibrator is enabled.

This sound will continue until the 100µF capacitor discharges, preventing the first transistor from operating. When the output of the first NAND gate becomes 0, the multivibrator shuts off. With the component values as shown in the schematic, the sound will last for about 10 seconds. Try substituting the 22kΩ with the 47kΩ or the 100kΩ resistor and see what occurs.

Part B: press the key and release it. When the sound stops, remove the wire between springs 52 and 54. What happens? Can you explain why?

## Notes:

## Wiring Sequence:

- 1-29
- 2-30
- 3-41
- 5-59-60-62-48-116-121
- 40-82
- 79-49-42-131-138
- 46-86
- 47-50-51-80
- 52-54
- 53-77-111
- 55-57-56-75-78
- 58-76-81-112
- 85-115-137
- 119-132

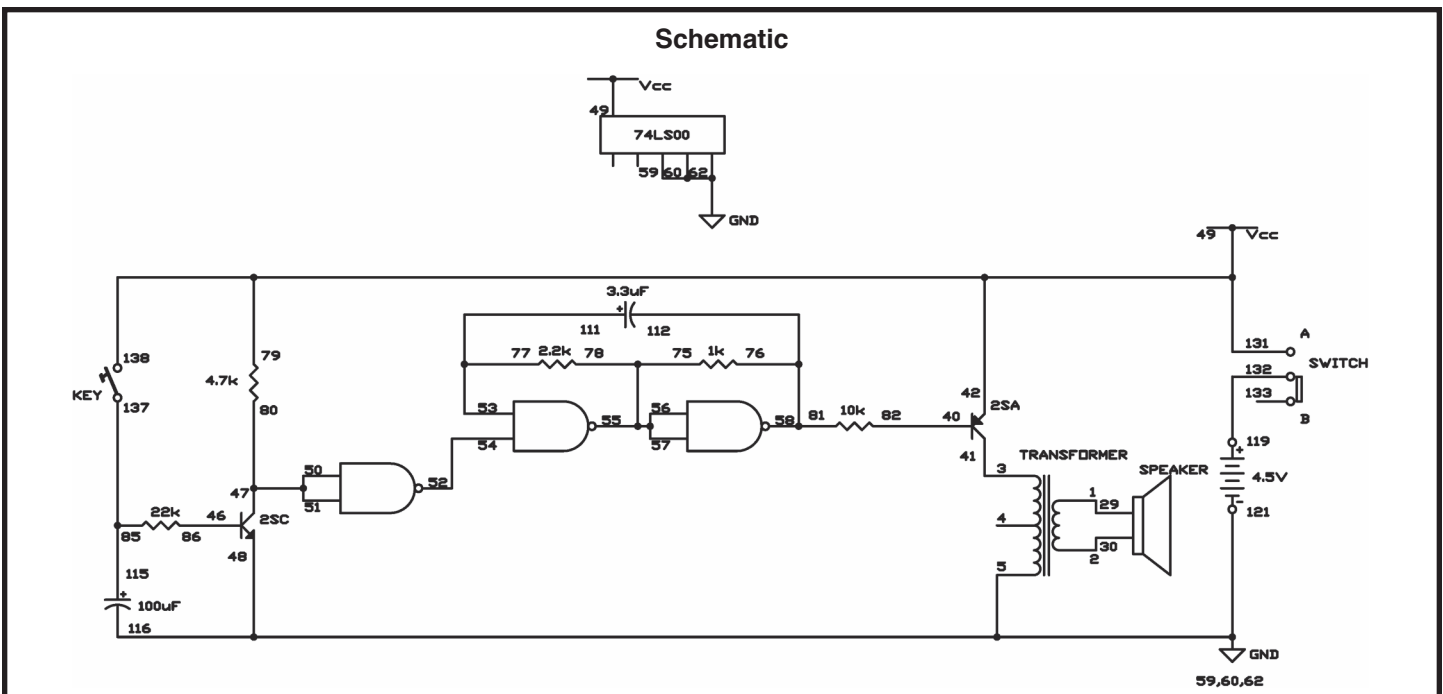



# EXPERIMENT #56: LED BUZZING

This is another circuit that uses both transistor and NAND type multivibrators. As you hear a sound through the earphone you see LED 1 light up.

Build the circuit, connect the earphone to terminals 13 and 14, and set the switch to position A. Each time the LED lights up you'll hear a pulse in the earphone. Do you know why?

Trace the output from the NAND multivibrator to the transistor multivibrator, assuming the output of the NAND multivibrator is 0. Do you think the NAND multivibrator affects the operation of the transistor multivibrator? If you respond yes, how is it affected?

Try using other electrolytic capacitors in place of the 100µF capacitor in the NAND multivibrator to see what effects they have on the circuit. Next, try changing the ceramic capacitors in the transistor multivibrator to other ceramic ones.

By connecting the NPN transistor, the output transformer, and maybe a resistor or two you can use the speaker instead of the earphone.

## Notes:

## Wiring Sequence:

- 31-55-56-57-76-116
- 33-59-60-62-72-80-121
- 40-109-85
- 131-45-42-49
- 43-105-81
- 50-51-77-115
- 52-53-54-75-78
- 58-82-86
- 119-132
- 110-44-71-89
- 90-13-EARPHONE
- 106-41-79-14-EARPHONE

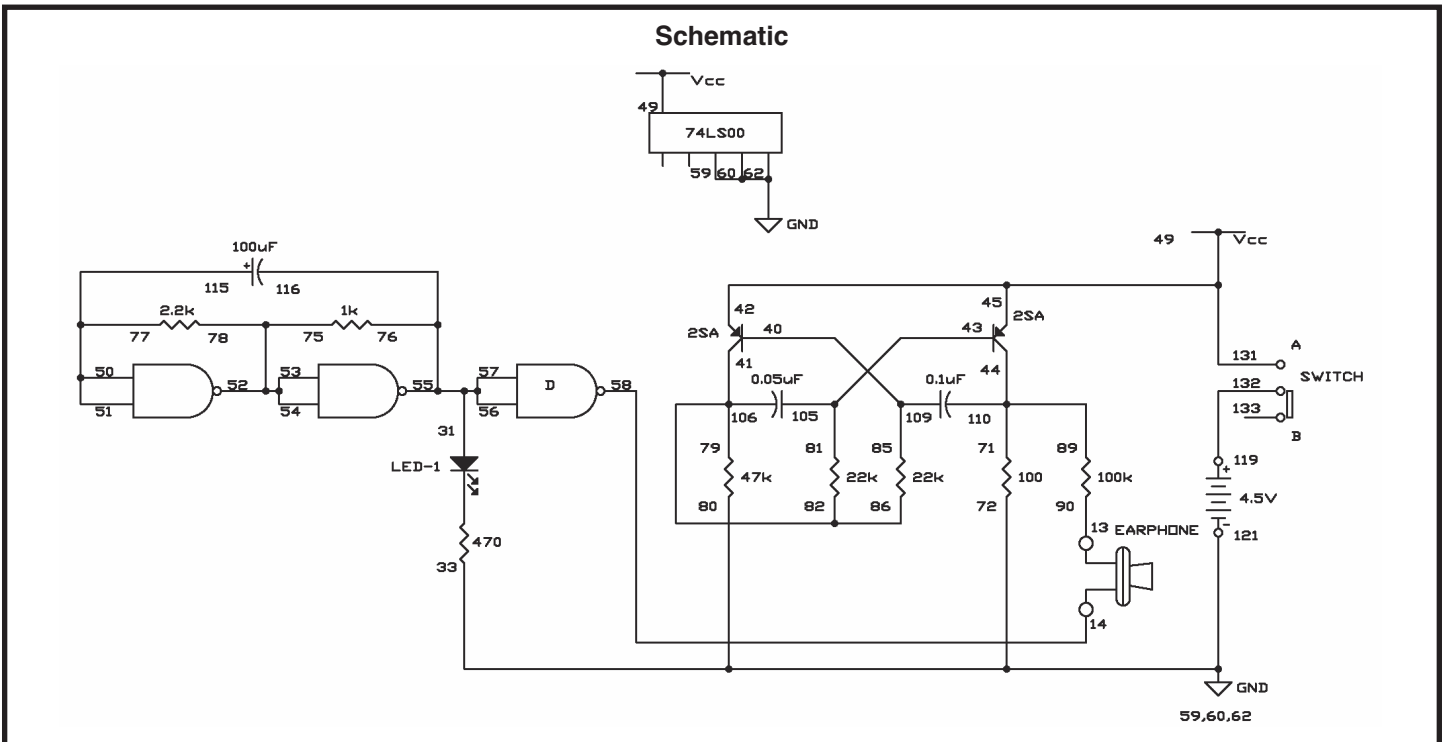

## EXPERIMENT #57: ANOTHER LED BUZZING

Carefully compare the schematic for this experiment with the schematic for the last experiment. While they are similar in many ways, but there's a critical difference. Can you find what it is? Can you tell how the operation will be different?

Attach the earphone to Terminals 13 and 14 and set the switch to position A. You will hear nothing in the earphone but you should find that LED 1 lights up. You will hear a sound in the earphone once LED 1 turns off.

Try to decipher why this happens. Examine the schematic and when you think you have the answer, read on to check your guess.

When the output of the NAND multivibrator is 0, the voltage at the junction of springs 42-58-33 is low. This allows current to flow through LED 1, but the transistor multivibrator won't work because there is no voltage to its left transistor. When the output of the NAND multivibrator is 1, the voltage at the junction of springs 42-58-33 is high. This prevents current from flowing through LED 1, but the transistor multivibrator now works because there is voltage to its left transistor, and this multivibrator controls the earphone sound.

### Notes:

### Wiring Sequence:

- 131-45-31-49
- 116-76-56-57-55
- 40-109-85
- 42-58-33
- 43-105-81
- 50-51-77-115
- 52-53-54-75-78
- 72-59-60-62-80-82-86-121
- 119-132
- 44-110-71-13-EARPHONE
- 41-106-79-14-EARPHONE

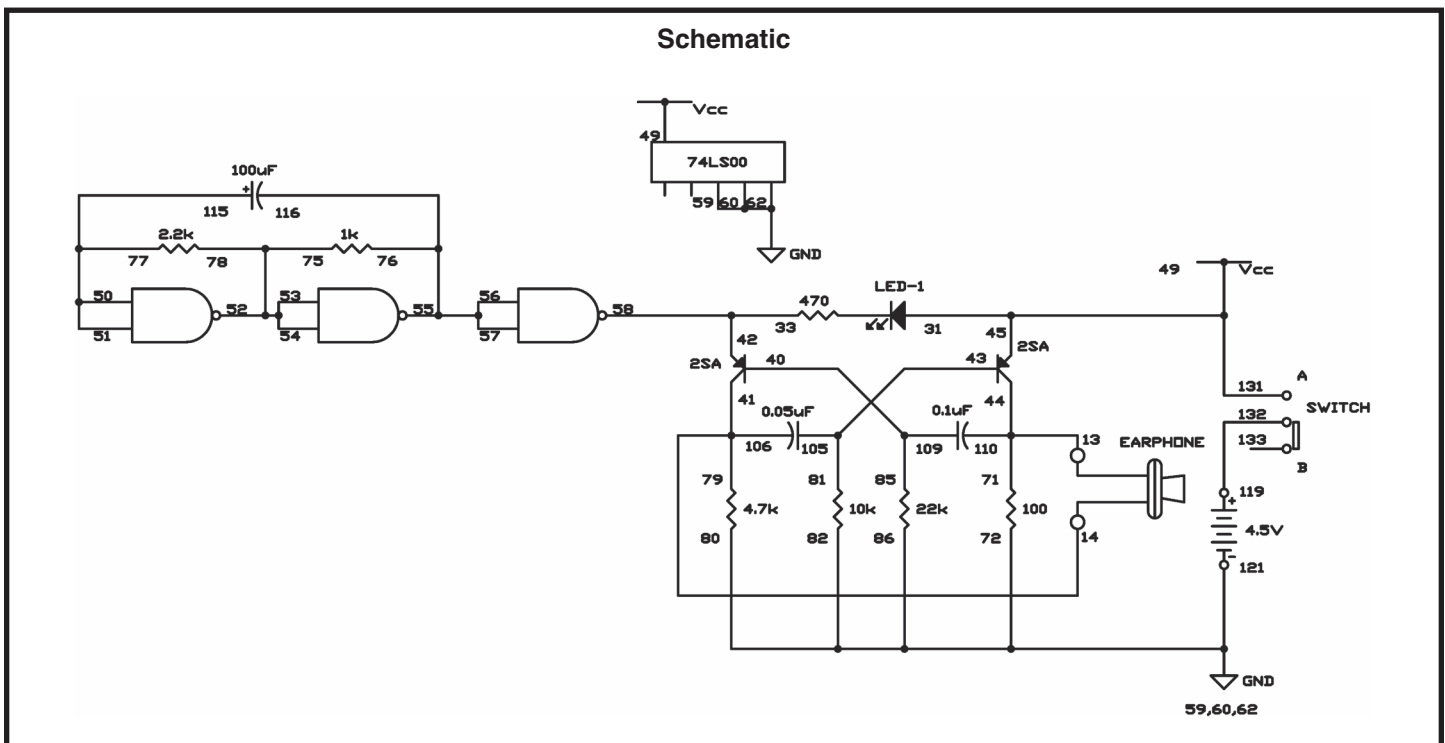

# EXPERIMENT #58: SET/RESET BUZZER

Does anything look familiar about the schematic for this project? This circuit uses an R-S flip-flop circuit made from NAND gates, comparable to the circuit in experiment 38 (R-S Flip-Flop using TTL).

Once you have finished building this project, set the switch to position A and press the key. A sound should result from the earphone. Try pressing the key multiple times. This should not alter the sound in your earphone. Now move the switch to position B and push the key one more time. What occurs now?

Circuits like this are used in alarms. Since intruders usually can't figure out how to make them stop, they are extremely useful.

## Notes:

## Wiring Sequence:

- 13-77-75-49-45
- 14-119
- 40-109-85
- 41-106-79
- 42-55-51
- 43-105-81
- 50-78-131
- 52-53
- 54-76-133
- 132-138
- 44-110-71-87
- 121-137-62-60-59-57-56-80-82-86-72
- 88-EARPHONE
- 82-EARPHONE
- 13-14 (POWER)

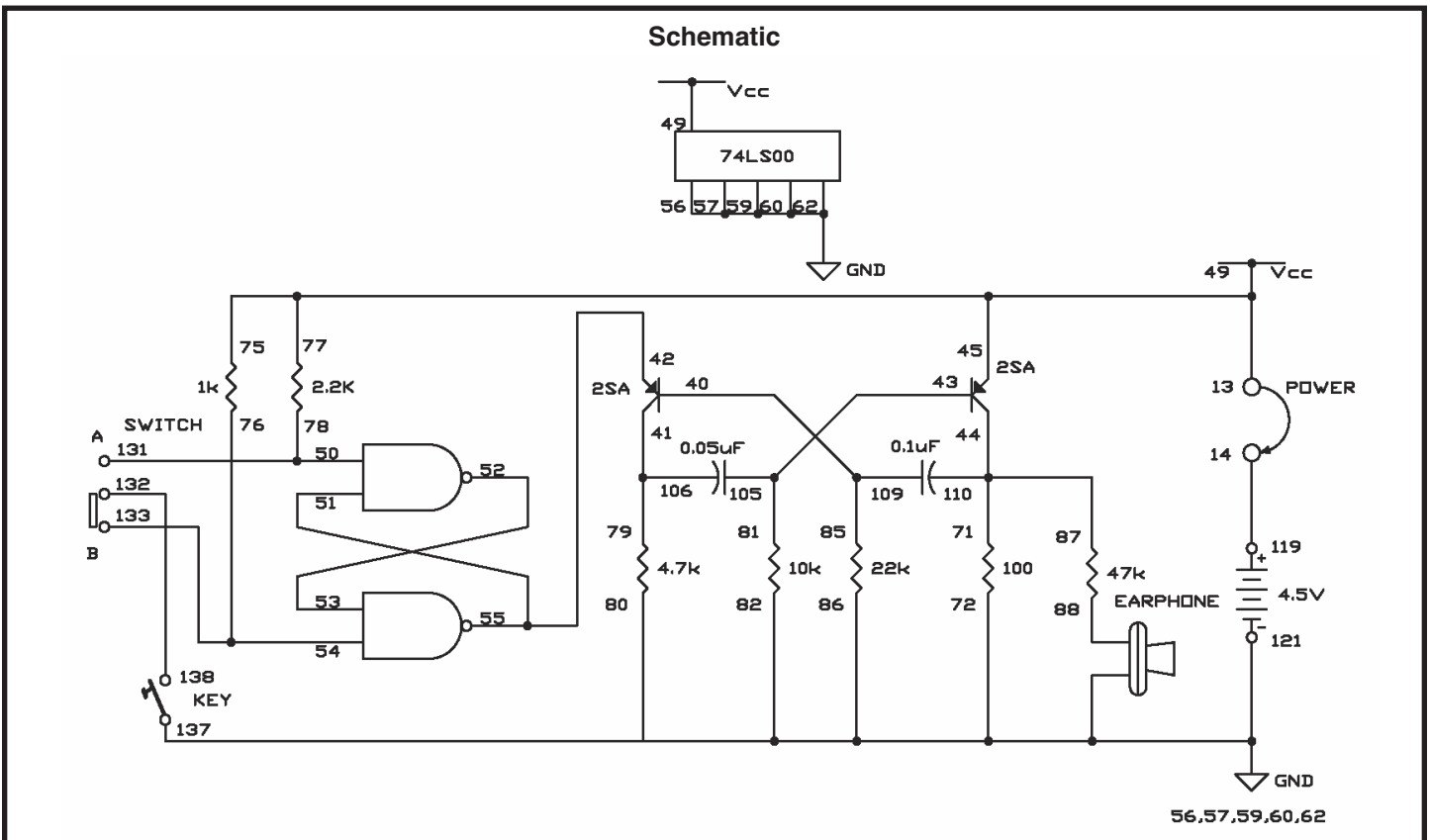

## EXPERIMENT #59: ANOTHER SET/RESET BUZZER

Here's a variant of the last project. This time we use an R-S flip-flop made with transistors and a NAND multivibrator.

You will hear a sound in the earphone when you set the switch to B and press the key. No matter how many times you press the key you can still hear the sound. The sound will stop when you set the switch to A and press the key.

Compare the operation of this experiment with the last one. What makes them independent from each other? Are you able to think of some situations where one circuit might be better suited than the other? Be sure to make some notes about what you are learning.

**Notes:**

### Wiring Sequence:

- 13-49-42-45-138
- 14-119
- 81-32-41
- 33-59-60-62-36-121
- 44-35-51-84
- 40-133-83
- 82-43-131
- 50-77-109
- 54-53-52-75-78
- 132-137
- 110-76-57-56-55-EARPHONE
- 58-87
- 88-EARPHONE
- 13-14 (POWER)

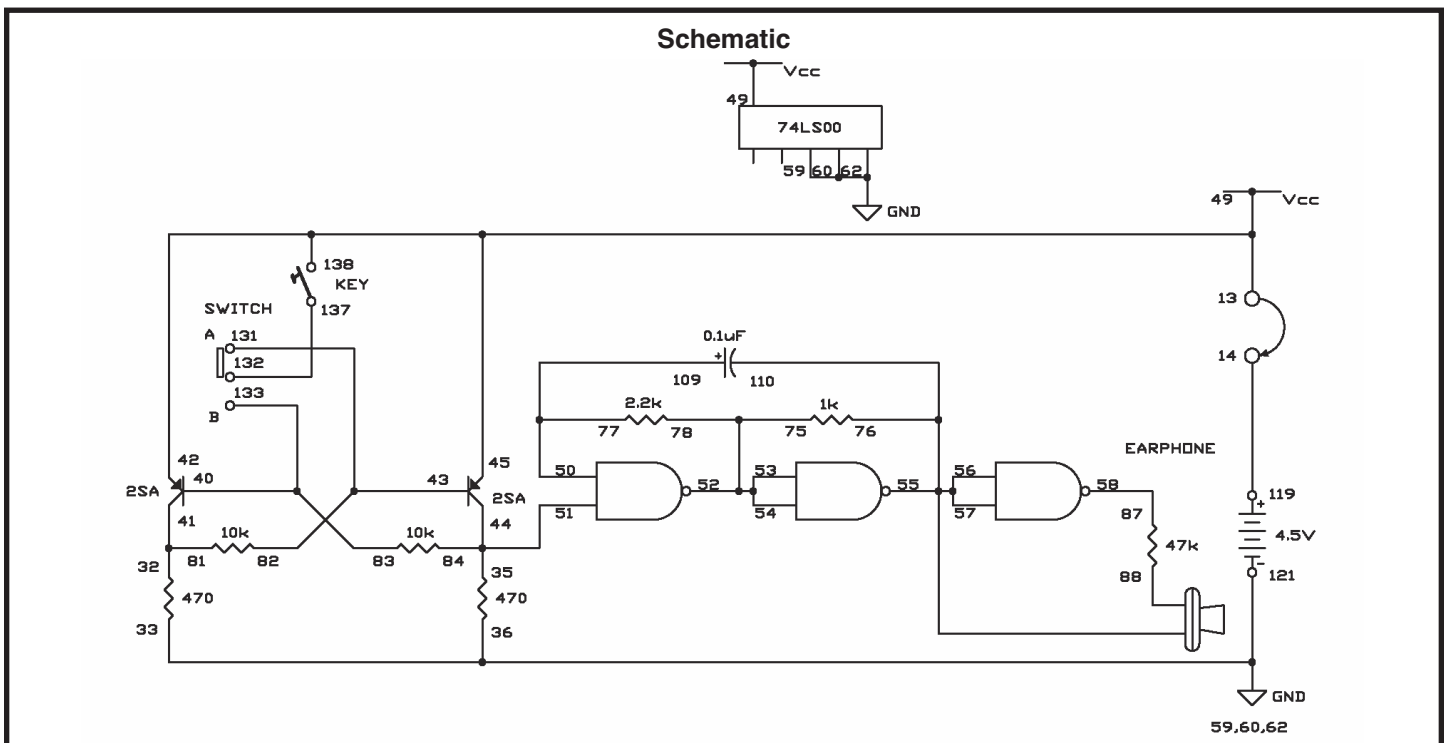

## **VII. OSCILLATOR APPLICATION CIRCUITS**

# EXPERIMENT #60: ODE TO THE PENCIL LEAD ORGAN

This experiment is an oscillator that is controlled in an abnormal way: with a pencil mark! You have caught a glimpse in other oscillator projects how changing the circuit's resistance can change the sound that is produced. Resistors, such as the ones in your kit, are made of a form of carbon, and so are pencils (we still call them "lead" pencils, even though they are now made with carbon, not lead). By causing the current to flow through different amounts of pencil lead, we can vary the resistance and consequently, the tone of the sound coming from the speaker.

**Notes:**

Make a very heavy pencil mark on a sheet of paper (a sharp #2 pencil works best) once you complete the wiring. The mark needs to be approximately half inch wide and 5 inches long.

Set the switch to position A to turn on the power, and hold one of the probe wires on one end of the mark. Move the other probe back and forth from one end of the mark to the other end of the mark. As you move the probe you'll hear the pitch rise and fall. After a little practice you should be able to play a tune with this organ.

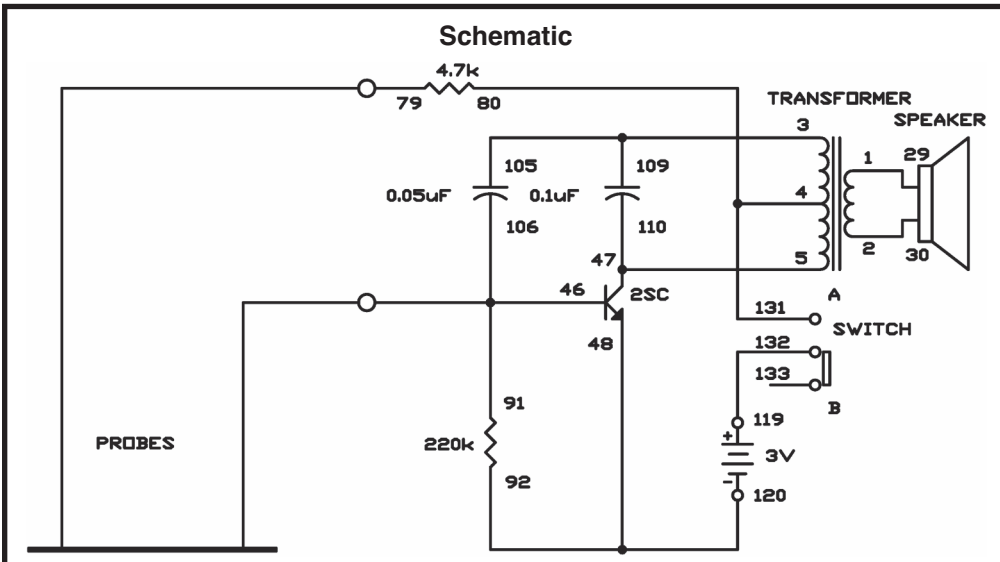

**Wiring Sequence:**

- 1-29
- 2-30
- 3-105-109
- 4-80-131
- 5-47-110
- 92-48-120
- 119-132
- 46-106-91-PROBES
- 79-PROBES

# EXPERIMENT #61: DOUBLE-TRANSISTOR OSCILLATOR

Now you will build an oscillator using two transistors connected directly to each other. As you have witnessed, there are many ways to make an oscillator. This way is easier compared to some.

After finishing the wiring, press the key. You hear a beep sound coming from the speaker. Now rotate the control. How does it change the sound?

The two transistors collaborate with each other and act as a single transistor. The NPN transistor amplifies the signal from the 22kΩ resistor and sends it to the PNP transistor, to obtain a larger output.

The frequency of the oscillation is determined by the capacitor. The project starts with the 0.01μF capacitor in the circuit but you can experiment with alternate value capacitors. The control alters the voltage leading to the base of the NPN transistors. It alters the tonal quality as well as the frequency. You should be sure to record your results like a professional scientist, so you can repeat the experiment later. If you alternate capacitor values, be sure to observe the polarity (+ and -) of the electrolytic capacitors.

## Notes:

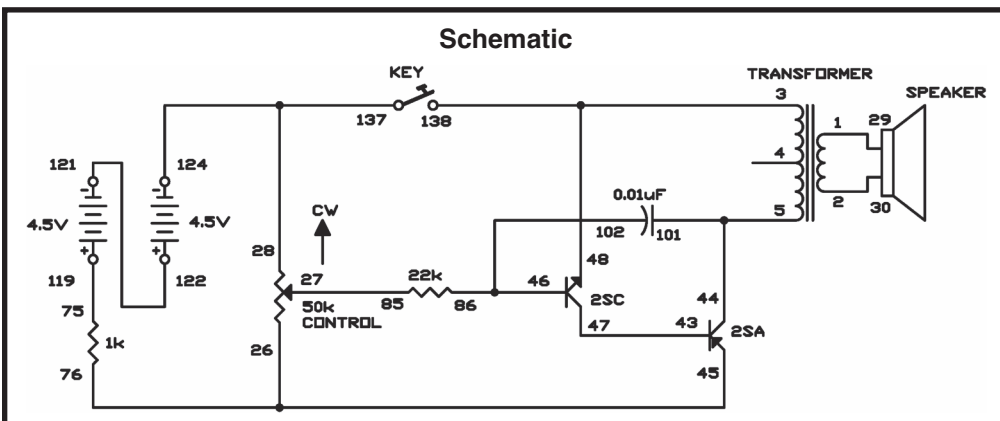

## Wiring Sequence:

- 1-29
- 2-30
- 3-48-138
- 5-101-44
- 26-45-76
- 27-85
- 28-124-137
- 46-102-86
- 47-43
- 75-119
- 121-122

# EXPERIMENT #62: DECIMAL POINT STROBE LIGHT

This circuit is an oscillator with a slow frequency, and you can see the LED lighting and turning off. The off time is longer than the on time, so you observe short pulses of light with long periods between them. The wiring sequence below will make the decimal point light, however you can light any part of the LED display.

**Notes:**

This type of circuit is known as a sawtooth wave oscillator, because the electrical waveform of the signal looks like a sawtooth pattern between two voltage values. The signal alters as the LED lights and turns off. Shorter pulses are generated when the output from the emitter of the PNP transistor supplies the base current to the NPN transistor (as in this circuit).

Try experimenting by altering the value of the 3.3µF capacitor to 10µF. You can also differ the 1kΩ resistor and alter the 470kΩ resistor to 220kΩ. The rate of charge and discharge of the capacitor controls the frequency of this oscillator. Changing its value or the values of the resistors that supply current to the capacitor alters the frequency.

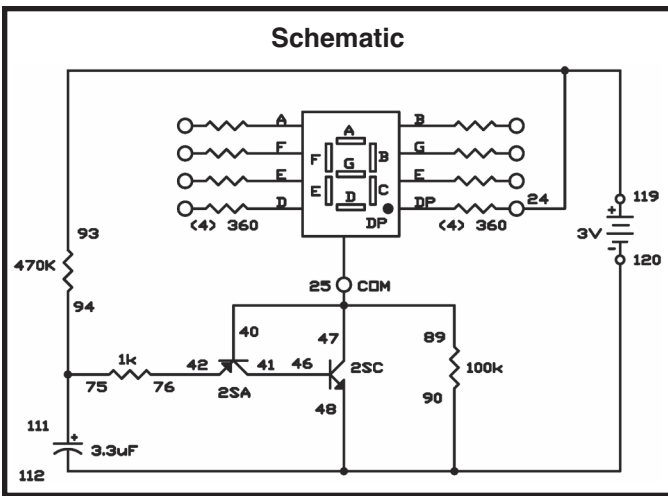

**Wiring Sequence:**

- 47-40-25-89
- 41-46
- 42-76
- 90-112-48-120
- 75-94-111
- 93-119-24



## EXPERIMENT #63: “THE EARLY BIRD GETS THE WORM”

This is the electronic bird circuit that you built for Project 6 (The Woodpecker), but now it has a photoelectric control of the transistor base. This circuit is activated by light, so you can use it as an early bird wake up alarm.

To make the sound of the bird, press the key. You can modify the control so that the right amount of light will set off the bird and wake you up in the morning – not too early and not too late.

From the original electronic bird, we have changed only a few component values, and rearranged the circuit schematic. See if you can find the changes and rearrange the circuit so that it looks like Project 6. Use the space provided to redraw the schematic.

Notes:

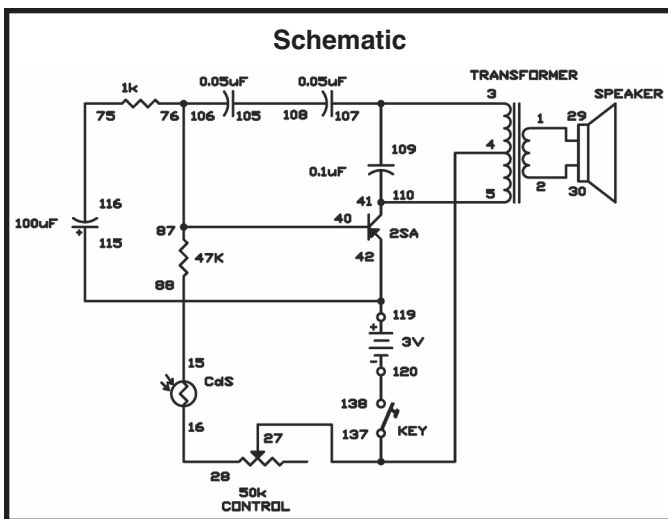

### Wiring Sequence:

- 1-29
- 2-30
- 3-107-109
- 4-27-137
- 5-41-110
- 15-88
- 16-28
- 76-87-106-40
- 119-42-115
- 75-116
- 105-108
- 120-138

## EXPERIMENT #64: ADJUSTABLE R-C OSCILLATOR

The “R-C” in this experiment’s name represents resistance-capacitance. You have seen how varying resistance and capacitance can affect the pulsing action of an oscillator. This experiment lets us see the effects when we can alter the strengths of both resistors and capacitors.

View the schematic. You can see the switch lets you choose between two different capacitors. Connecting terminals 13 and 14 adds another resistor to the circuit.

Build the circuit and set the switch to position B. Press the key, and leave terminals 13 and 14 unconnected. What kind of sound comes from the speaker? Now set the switch to A and press the key another time. Is there any difference in the sound? Now attach terminals 13 and 14 and press the key. Try both settings of the switch with terminals 13 and 14 attached and see what occurs.

Which combination gives you the highest tone? The lowest? What does this show you about how capacitors and resistors affect each other? Take meticulous notes about the effects of the different value capacitors and resistors.

### Notes:

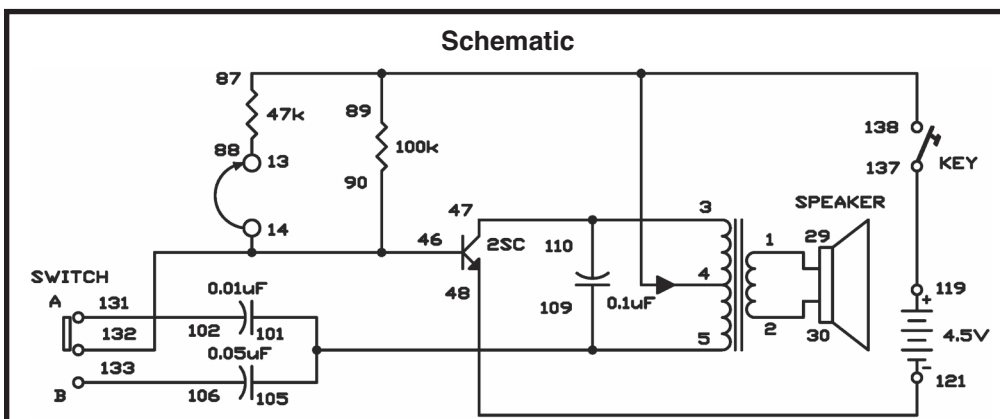

### Wiring Sequence:

- 1-29
- 2-30
- 3-47-110
- 4-87-89-138
- 5-101-105-109
- 13-88
- 14-90-46-132
- 48-121
- 102-131
- 106-133
- 119-137

## EXPERIMENT #65: HEAT-SENSITIVE OSCILLATOR

Did you know that a transistor alters its characteristics according to the temperature? This experiment will show you how temperature affects transistor action.

View the schematic. The NPN transistor acts as a pulse oscillator. The 22k $\Omega$  resistor and the PNP transistor control the voltage applied to its base. The transistor's base current and collector current vary with the temperature.

Build this experiment and you will hear a sound from the speaker. Modify the 50k $\Omega$  control so that the sound is low or a series of pulses.

Hold the PNP transistor between your fingers to warm it up. As the transistor temperature increases you will hear the tone become higher.

Notes:

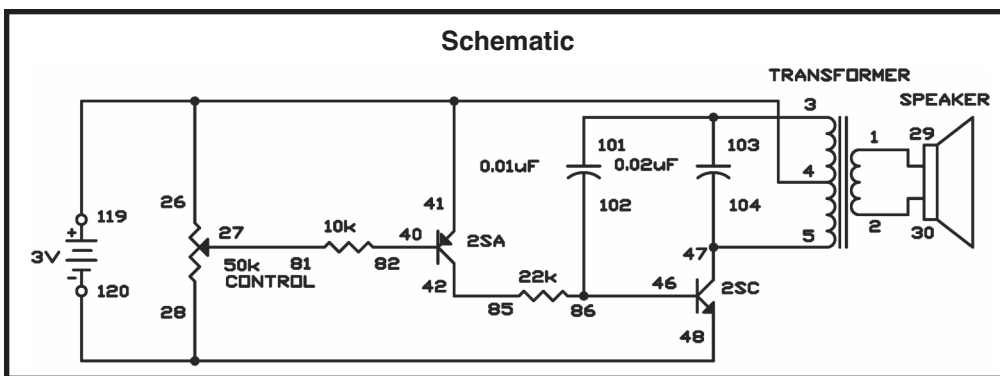

Wiring Sequence:

- 1-29
- 2-30
- 3-101-103
- 4-26-41-119
- 5-47-104
- 27-81
- 120-28-48
- 40-82
- 42-85
- 46-102-86

## EXPERIMENT #66: PULSE ALARM

Now you will let one oscillator control another to create an alarm. Here we have a multivibrator-type oscillator controlling a pulse oscillator. The pulse oscillator produces frequency in the audible range (the range that our ears can hear, about 20 to 20k Hertz). The multivibrator circuit on the left side of the schematic should look familiar. The multivibrator commands the pulse oscillator by allowing current to flow to the transistor base.

Build the experiment and press the key to hear the alarm sound coming from the speaker. You hear the alarm resonate turning on and off as the pulse oscillator turns on and off.

This intermittent sounding alarm is more beneficial than a continuous tone, because it is more noticeable. You can experiment with this experiment by varying the values of the 22k $\Omega$ , 47k $\Omega$ , and 100k $\Omega$  resistors, and the 0.02 $\mu$ F capacitor.

### Notes:

#### Wiring Sequence:

- 1-29
- 2-30
- 3-103-109
- 4-42-45-138
- 5-47-110
- 40-113-87
- 41-112-75
- 43-111-85
- 44-114-73-89
- 46-104-90
- 76-86-88-74-48-124
- 119-137
- 121-122

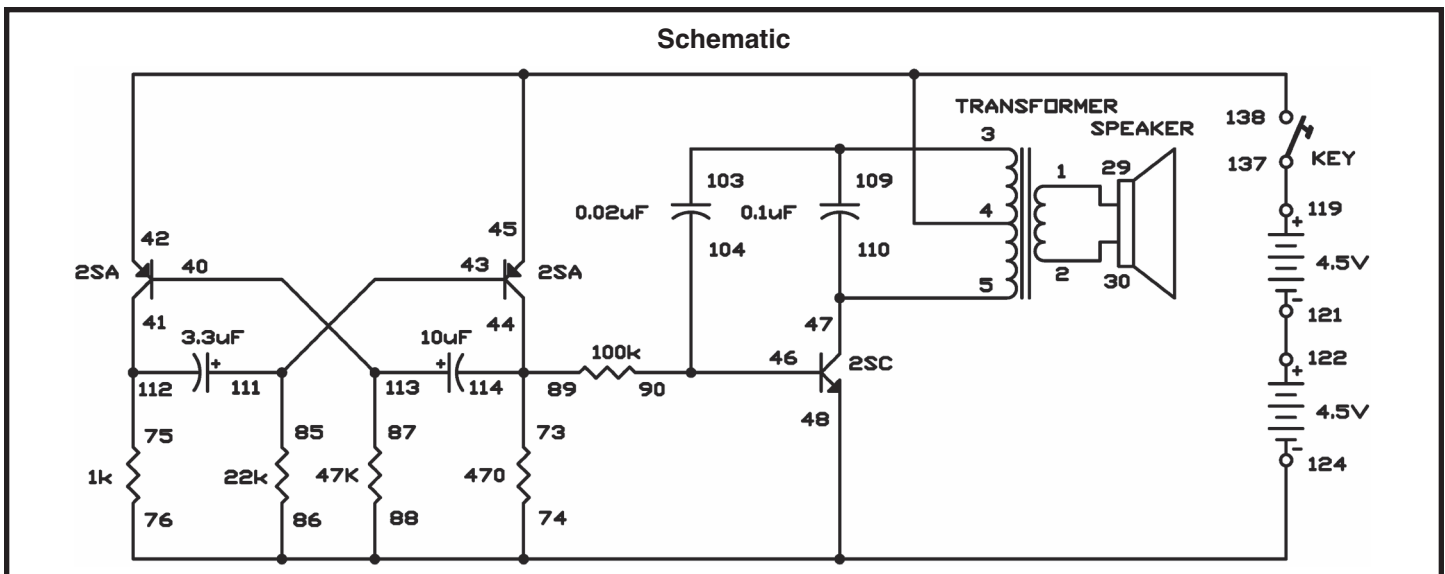

## EXPERIMENT #67: PUSHING & PULLING OSCILLATOR

In this experiment you will make a push/pull, square wave oscillator. This oscillator is known as a push/pull because it uses two transistors that are connected to each other. They take turns maneuvering so that while one transistor is “pushing,” the other is “pulling.” This type of oscillator is called a square wave oscillator because the electrical waveform of the signal has a square shape.

Slide the switch to position A to turn on the power after wiring the circuit. We will be using square wave signals in later projects therefore, note the sound from the speaker.

### Notes:

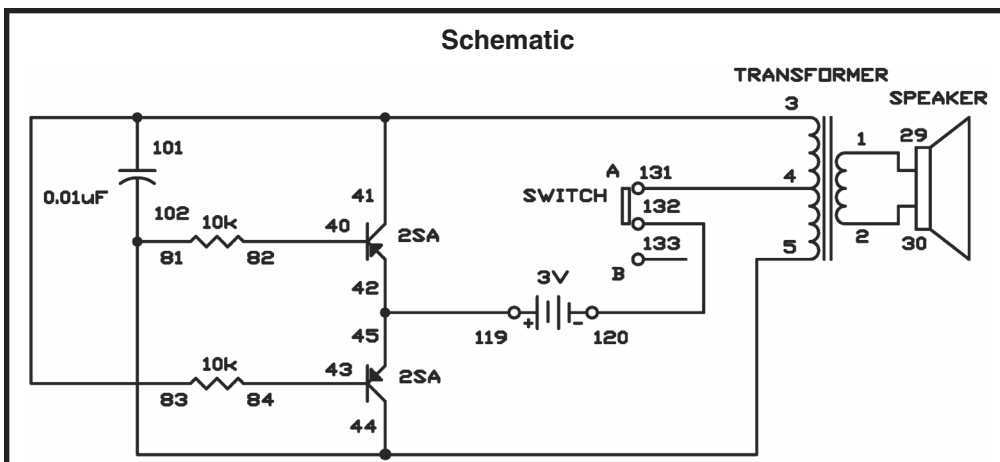

### Wiring Sequence:

- 1-29
- 2-30
- 3-83-101-41
- 4-131
- 5-81-102-44
- 40-82
- 45-42-119
- 43-84
- 120-132

## EXPERIMENT #68: SLOW SHUT-OFF OSCILLATOR

You have seen how a capacitor's charge/discharge cycle can be used to delay certain circuit operations. Now let's slow the oscillator action in this project with a 470 $\mu$ F capacitor.

Press and release the key. The circuit oscillates, but slowly shuts down as the capacitor charges up. When the capacitor is fully charged, no current can flow to the oscillator, and it is off. When you press the key, it instantly discharges the capacitor, and the oscillator resumes working.

On its positive (+) and negative (-) electrodes, a discharged capacitor has an equal number of electrons. Electrical charge is stored in a capacitor by drawing electrons from the positive electrode (to actually make it positive) and adding an equal number of electrons to the negative electrode (to make it negative). Charging current or displacement current is the current that flows to charge the capacitor. The same amount of current must flow in the opposite direction when the capacitor is discharging. This current is known as discharge current or displacement current.

With the voltmeter function if you have a VOM, use it to measure the charge on the capacitor. The displacement current can be measured with the current function.

This electrical-storage ability makes capacitors useful in many different ways. However, this storage ability can be dangerous in very high voltage circuits due to possible shock if you are not careful with it. You need to discharge capacitors before touching them if they use voltages above 50V.

### Notes:

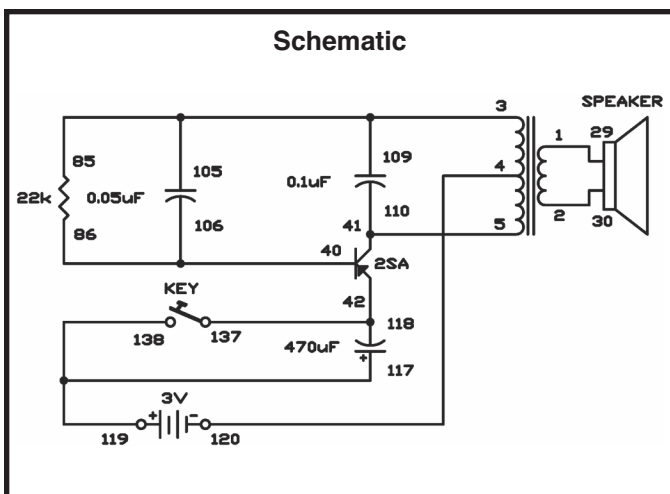

### Wiring Sequence:

- 1-29
- 2-30
- 3-85-105-109
- 4-120
- 5-41-110
- 40-106-86
- 42-118-137
- 117-138-119

## EXPERIMENT #69: ELECTRONIC ORGAN OSCILLATOR

This circuit has a multivibrator connected to a pulse type oscillator. Rather than turning the oscillator completely on and off, the multivibrator provides a tremolo effect (a wavering tone).

After you build the circuit, use the control to vary the base current supplied to the NPN transistor. This changes the charge/discharge rate of the  $0.1\mu\text{F}$  and  $0.05\mu\text{F}$  capacitors, as well the frequency of the pulse oscillator.

The key works to turn the whole circuit on and off. You can substitute it with the slide switch. By changing the  $10\mu\text{F}$  and  $3.3\mu\text{F}$  capacitor values, you can change the tonal range.

Try using the switch or the key to add additional components to the circuit (like an extra capacitor in parallel with the  $10\mu\text{F}$  or  $3.3\mu\text{F}$ ), so you can alter from one tonal range to another, quickly. These changes will make a more complete organ from this experiment. Be sure to make notes on what you do.

### Notes:

#### Wiring Sequence:

- 1-29
- 2-30
- 3-47-106
- 4-74-45-42-119
- 5-105-109
- 27-46-110
- 28-86
- 40-111-80
- 41-114-78
- 43-113-82
- 44-112-87-76
- 77-75-81-79-48-138
- 73-85-88
- 120-137

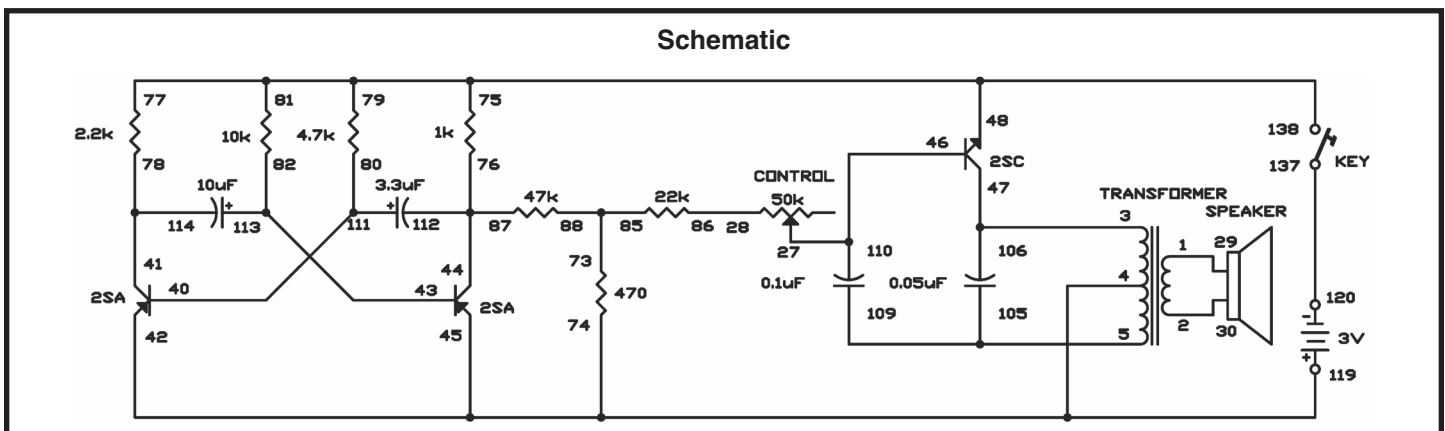

## **VIII. MEET THE OPERATIONAL AMPLIFIER**



## EXPERIMENT #70: OPERATIONAL AMPLIFIER COMPARATOR

For this section you will need some basic understanding about the operational amplifier integrated circuit. First, we can use separate power sources or we can use one power source for both the circuit and the IC.

The operational amplifier (often called “op amp” for short) can be operated as a non-inverting amplifier, an inverting amplifier, or a differential amplifier. A non-inverting amplifier reproduces an input signal as an output signal without any alteration in polarity. An inverting amplifier does the reverse: its output has the reverse polarity of its input. The differential amplifier has an output that is the contrast between the strengths of the two input signals.

Comparing two voltages and telling you which one is stronger than the other is the job of a comparator. We call the controlled voltage the reference voltage because we use it as a reference for measuring other voltages. The voltage that is compared is the input voltage.

The reference voltage in this experiment is about 3.7V. It is connected to terminal 68 of one of the op amp integrated circuit. Input voltage is connected to terminal 69 of the same IC. The LED will light if this input voltage is higher than the reference voltage, and the LED stays off if it is lower. The operational amplifier acts as an inverting amplifier for the reference voltage to keep the LED turned off, or as a non-inverting amplifier to light the LED.

Build the experiment and then set the switch to position A. This supplies an input of 6V. The LED lights because the input voltage is higher than the reference voltage. Now slide the switch to position B. This supplies an input voltage of 1.5V. The comparator IC does not turn on the LED, because the input voltage is now lower than the reference voltage.

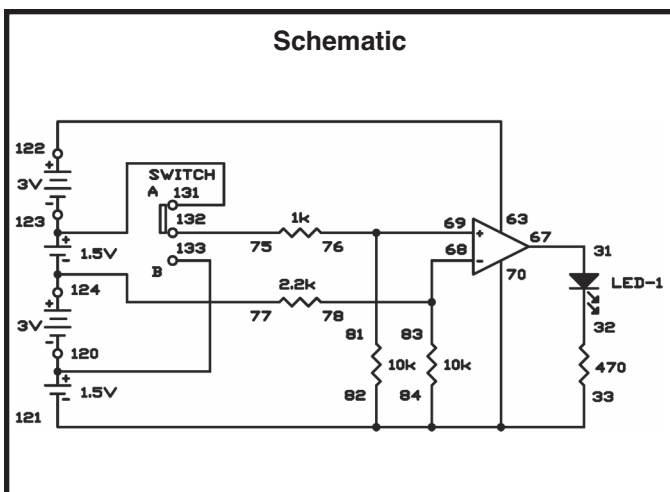

### Notes:

### Wiring Sequence:

- 31-67
- 84-82-33-70-121
- 63-122
- 68-83-78
- 69-81-76
- 75-132
- 77-119-124
- 120-133
- 123-131

## EXPERIMENT #71: CHANGING INPUT VOLTAGE

After you finish the wiring, set the switch to position B.

LEDs 1 and 2 indicate the output voltage of the operational amplifier IC. An LED lights if it is connected to 1.5V or higher. In this experiment, we connect the two LEDs in series, so they only light when connected with about 3V. When they are off, the output voltage of the operational amplifier must be less than 3V.

View the schematic diagram. With the switch at position B, the 1.5V battery voltage is connected to two 10kΩ resistors, with the positive terminal of the operational amplifier connected between the resistors. These two 10kΩ resistors divide the 1.5V supply voltage in half. This signifies the positive input terminal receives an input voltage of only 0.75V.

To total the output voltage of the operational amplifier you multiply its input voltage by the amplification factor  $(R1/R2) + 1$ . So, the output voltage is  $0.75V \times ((220k\Omega / 100k\Omega) + 1) = 2.4V$ .

Slide the switch position A. This eliminates the 10kΩ resistors from the circuit, so the amplifier's positive input terminal receives the full 1.5V input voltage. Using the above equation, you can see that the output voltage of the operational amplifier is now  $1.5V \times ((220k\Omega / 100k\Omega) + 1) = 4.8V$ . Because the voltage supplied to them is more than 3V, the LEDs light dimly.

Let's alter the amplification factor. Slide the switch to position B again and press the key. This adds the 47kΩ resistor to the 100kΩ resistor in parallel, making total resistance of R2 about 32kΩ. Now the output voltage is  $0.75V \times ((220k\Omega / 32k\Omega) + 1) = 5.9V$ , enough to light the LEDs brightly.

Now slide the switch to position A again (to connect 1.5V to the amplifier's positive (+) input terminal),

and press the key. The LEDs light brightly. Calculating the output voltage gives  $1.5V \times ((220k\Omega / 32k\Omega) + 1) = 11.8V$ . However, the actual output voltage will be limited by the available battery voltage, which is  $1.5V + 3.0V + 3.0V = 7.5V$ .

### Notes:

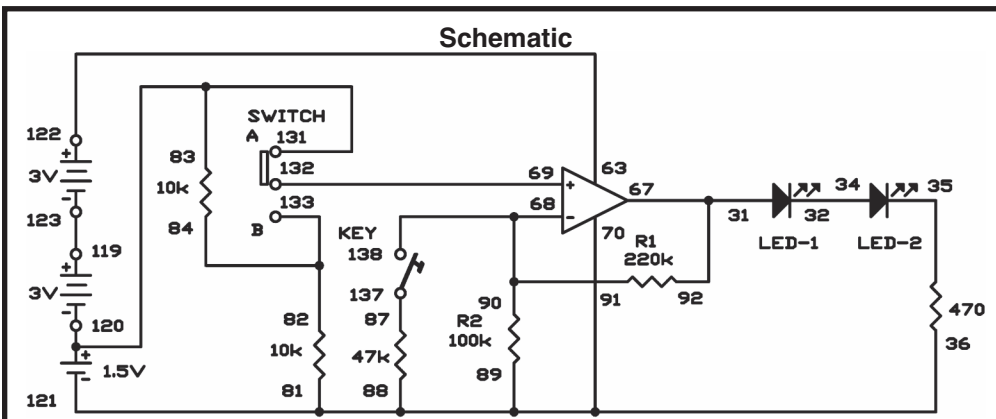

### Wiring Sequence:

- 31-67-92
- 32-34
- 81-89-88-70-36-121
- 63-122
- 68-90-91-138
- 69-132
- 82-84-133
- 83-131-120
- 87-137
- 119-124

# EXPERIMENT #72: NON-INVERTING DUAL SUPPLY OP AMP

In this experiment, you will make a microphone amplifier, using the operational amplifier (op amp) as a non-inverting amplifier with two power sources. The earphone acts as a microphone.

### Notes:

Begin by sliding the switch to position B and finishing the wiring for the circuit. When your wiring is ready, set the switch to position A to turn on the power. Now rotate the control fully clockwise, and lightly tap your “microphone” – the earphone. The tapping sound is heard through the speaker.

The earphone is a better microphone if you remove the end that you put in your ear, by turning it counter-clockwise to unscrew it. To adjust the volume, turn the control.

As you can observe in the schematic, the operational amplifier uses two power sources: 4.5V for the circuit and 9V for the IC. The signal from the earphone is connected to the operational amplifier’s non-inverting input through the control. The input is amplified, and the output is applied to the transformer. The gain through the amplifier is about 100, determined by the ratio  $R1/R2$  ( $100k\Omega / 1k\Omega = 100$ ).

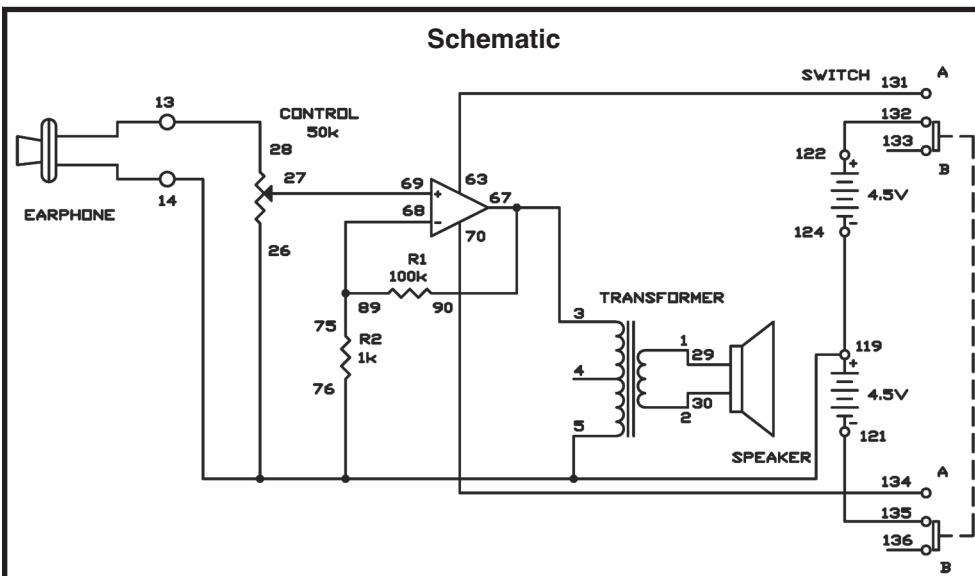

### Wiring Sequence:

- 1-29
- 2-30
- 3-67-90
- 27-69
- 63-131
- 68-89-75
- 70-134
- 121-135
- 122-132
- 124-119-26-76-5-14-EARPHONE
- 28-13-EARPHONE

## EXPERIMENT #73: INVERTING DUAL SUPPLY OP AMP

This is another two-power source microphone amplifier, but this one is an inverting amplifier. You will use the earphone as a microphone again.

Slide the switch to position B and construct the circuit. Once you finish the wiring, slide the switch to position A to turn the power on, adjust the control clockwise, and speak into the “microphone” – the earphone. This project works just like the preceding one.

IC 2 is an inverting amplifier and IC 1 is used as a buffer between the earphone and IC2, and has a gain of 1. IC2 is an inverting amplifier, with the input applied through its negative (–) terminal, not the positive (+) one as in our last project. IC2’s gain is about 100, as determined by:

$$R1/R2 = 100k/1k=100.$$

If you increase R1 or decrease R2, the gain becomes larger. See what occurs to the gain when you alter the value of R2 to 470.

### Notes:

#### Wiring Sequence:

- 1-29
- 2-30
- 3-64-90
- 27-69
- 63-131
- 65-89-76
- 68-67-75
- 70-134
- 121-135
- 122-132
- 124-119-26-66-5-14-EARPHONE
- 28-13-EARPHONE

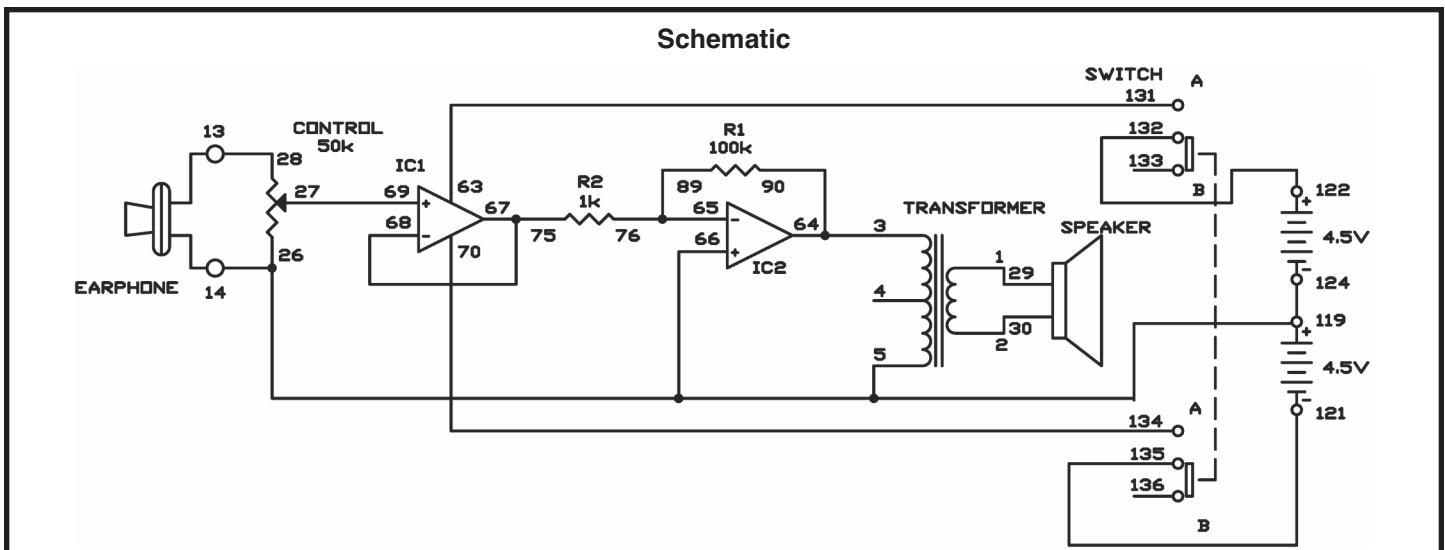

## EXPERIMENT #74: NON-INVERTING AMPLIFIER

In Projects 72 and 73 (“Non-inverting Dual Supply Op Amp,” and “Inverting Dual Supply Op Amp,” respectively), we used the operational amplifier with two power sources. In this experiment, we will make a single-power source, non-inverting microphone amplifier. Again, the earphone works as a microphone.

### Notes:

Slide the switch to position B and assemble the circuit. When you completed the wiring, slide the switch to position A to turn on the power, alternate the control clockwise, and speak into the microphone. The experiment works just like Projects 72 and 73, but you’ll notice something different.

The contrast comes from the gain of this microphone amplifier. It is still determined by R1 and R2, but now it’s much bigger. Can you observe why? Yes, we use the 100Ω resistor in place of the 1kΩ resistor from the last two experiments. Try changing R2 to 1kΩ, and the gain drops to the level of the last experiments.

In this experiment, two power sources are connected in series to operate the dual operational amplifier at 9V. But the operational amplifier can work at half this voltage, at 4.5V. See what occurs when you disconnect the operational amplifier from battery terminal 122 and connect it to terminal 119.

### Wiring Sequence:

- 1-29
- 2-30
- 3-116
- 27-112
- 71-114
- 81-63-131
- 67-90-115
- 89-68-113
- 84-82-69-111
- 119-124
- 122-132
- 121-26-70-83-72-5-14-EARPHONE
- 28-13-EARPHONE

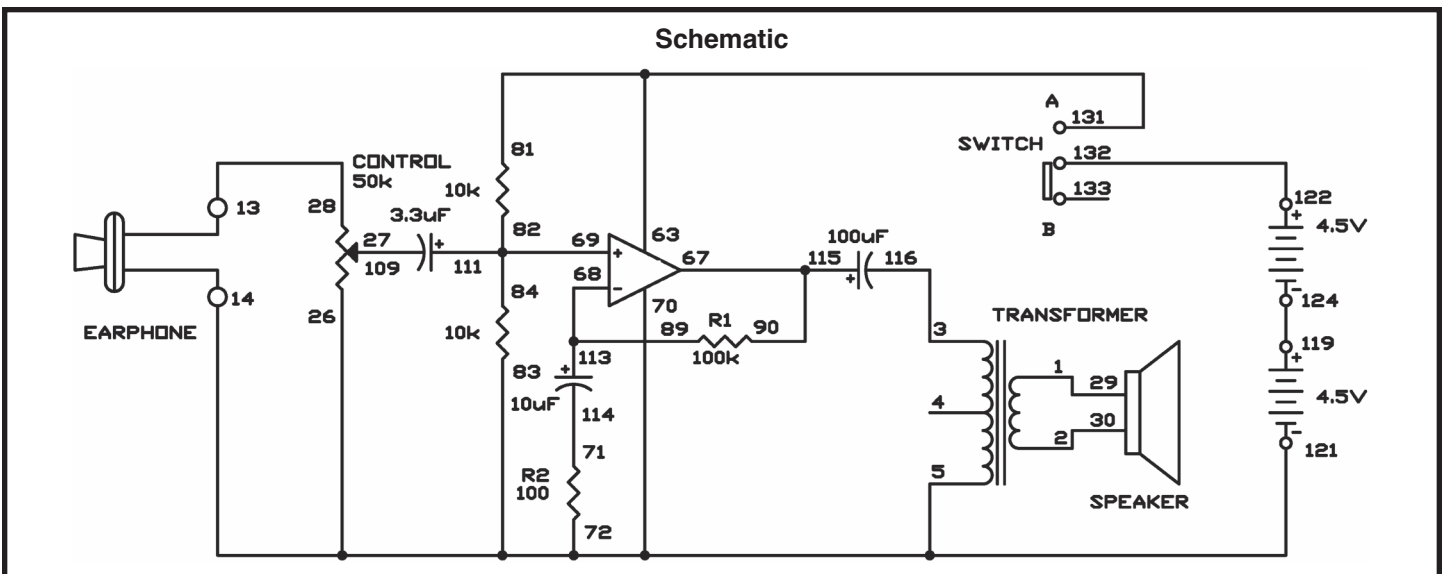

## EXPERIMENT #75: DUAL-SUPPLY DIFFERENTIAL AMPLIFIER

This is the last in the series of microphone amplifiers. Now you will use the operational amplifier as a differential amplifier. It is a two-power source type amplifier, and this time we use the speaker as a microphone.

Slide the switch to position B and construct the circuit. When you finish the wiring, apply the earphone to your ear, slide the switch to position A to turn on the power, and tap the speaker lightly with your finger.

In this circuit the operational amplifier is configured to amplify the difference between its positive (+) and negative (-) inputs, so we call it a differential amplifier. The speaker is connected to the transformer, which is then connected to the amplifier's inputs, so the speaker signal will be amplified.

In a speaker, an electrical signal flows through a coil and creates a magnetic field; the magnetic field changes as the electrical signal changes. The magnetic field is used to move a small magnet, and this movement creates variations in air pressure, which travel to your ears and are interpreted as sound.

This circuit uses the speaker as a microphone. In this arrangement, your voice creates variations in air pressure, which move the magnet inside the speaker. The moving magnet's magnetic field creates an electrical signal across both ends of a coil. This small signal is applied to the primary of the transformer, which then results in larger signal at the secondary side of the transformer.

This circuit is simplified by using the speaker as a microphone. To use the earphone as in previous experiments, you would have to make a far more complex circuit.

### Notes:

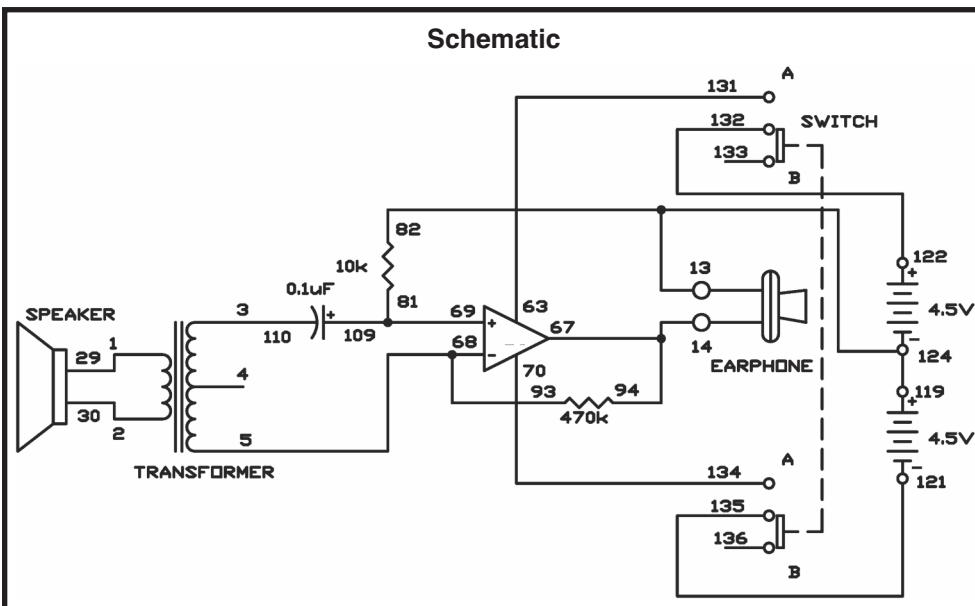

### Wiring Sequence:

- 1-29
- 2-30
- 3-110
- 5-68-93
- 63-131
- 69-81-109
- 70-134
- 121-135
- 122-132
- 124-119-82-13-EARPHONE
- 94-67-14-EARPHONE

# EXPERIMENT #76: MILLER INTEGRATING CIRCUIT

You know that an LED promptly lights when you turn it on. You can also light it up gradually. In this project, you'll be able to observe the LEDs slowly get brighter while you hold down the key.

### Notes:

This circuit arrangement is called a Miller integrating circuit. The output of the circuit increases as its input rises. The integrating circuit increases the value of the 100 $\mu$ F capacitor above its actual value. When you press the key, the LEDs become brighter and the capacitor charges slowly through resistor R. Setting the switch to position B discharges the capacitor, and the LEDs turn off.

Before completing the project, set the switch to position B, to discharge the capacitor. Set the switch to position A and hold the key down to watch LEDs 1, 2, and 3 become brighter. In about 5 seconds they will reach maximum brightness. Now set the switch to B to discharge the capacitor, then hold down the key to do the experiment again.

### Wiring Sequence:

- 31-63-122-137
- 32-34
- 35-37
- 38-72
- 71-67-116-133
- 68-90-115-132
- 69-124-119
- 70-121
- 89-138

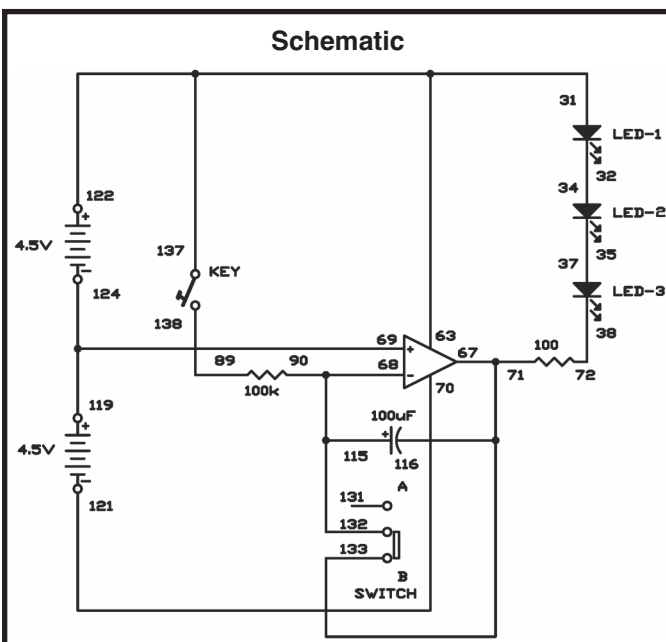

## EXPERIMENT #77: STABLE-CURRENT SOURCE

In this experiment, we will make a constant current circuit, using an operational amplifier and a transistor. This circuit maintains a constant current even when the input voltage is changed, because more energy is used up in the circuit.

View the schematic. When the current is modified, the voltage across R1 is also modified. The output of the operational amplifier changes corresponding to the feedback signal from R1. This output from the amplifier controls the base voltage of transistor Q1 allowing it to maintain the continual current.

First set the switch to position A, and press the key while monitoring LED 1. When the key is pressed it gets dimmer. This occurs because both LED 1 and LED 2 are in the circuit when the key is closed. The total current through the circuit is the same, but now it is split between LED 1 and LED 2, so LED 1 gets dimmer.

Set the switch to position B with the key off. Do you notice any changes in LED brightness from position A to position B? Setting the switch to B modifies the supply voltage from 9V to 6V. However, the current remains constant again, so the LED brightness is not affected.

### Notes:

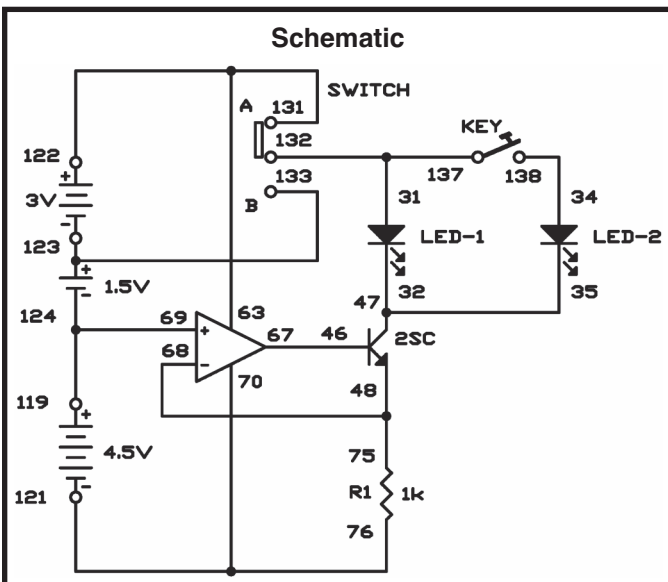

### Wiring Sequence:

- 31-132-137
- 32-35-47
- 34-138
- 46-67
- 48-68-75
- 63-131-122
- 69-119-124
- 76-70-121
- 123-133



## EXPERIMENT #78: OPERATIONAL AMPLIFIER BLINKING LED

Now you're going to make a blinking LED circuit using an operational amplifier. In this experiment, an LED continuously lights and turns off slowly.

### Notes:

Slide the switch to position B and connect the wires for this circuit. When you finish connecting the project, slide the switch to position A to turn on the power. After a couple seconds, you'll see the LED start to blink. Watch carefully and you should be able to observe that its on and off periods are about equal.

The operational amplifier works as an astable multivibrator at low frequency. You can alter the period of oscillation (the LED blinking rate) by using different values for R and C. See what happens to the blinking rate when you make the value of R 220k $\Omega$ .

One last thing - the operational amplifier has high input resistance at its inputs - so there is very little current flowing into its inputs. This means you can operate it to build accurate blinkers and timers with longer intervals.

### Wiring Sequence:

- 81-31-63-131
- 33-67-90-94
- 93-68-113
- 69-82-84-89
- 83-70-114-121
- 119-124
- 122-132

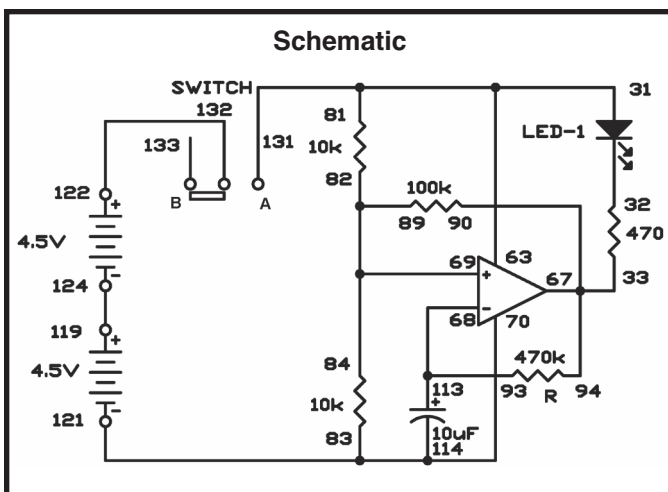

## EXPERIMENT #79: LED FLASHER

Begin by sliding the switch to position B and wiring the circuit. This LED flasher uses two diodes. As you build this experiment, be sure to connect these diodes in the correct direction.

When you finish assembling the experiment, turn on the power by sliding the switch to position A, and press the key. The LED starts blinking immediately. Even if you don't press the key, this LED flasher starts flashing shortly after you turn on the power; if you press the key, it begins blinking right away.

This LED flasher uses an operational amplifier as an astable multivibrator, but its flashing time is much shorter because of the two diodes.

**Notes:**

### Wiring Sequence:

- 81-31-63-131-138
- 33-67-88-90-76
- 68-115-137-128-125
- 69-87-82-84
- 83-70-116-121
- 75-127
- 89-126
- 119-124
- 122-132

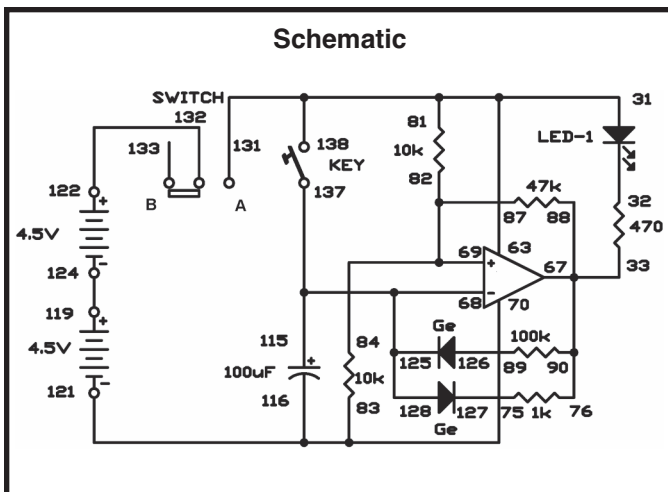

## EXPERIMENT #80: DOUBLE LED BLINKER

The LED circuits in experiments 78 and 79 (“Operational Amplifier Blinking LED” and “LED Flasher”) each use one LED, but the circuit in this project uses two LEDs that take turns lighting. Slide the switch to position B and assemble the circuit. Then, turn the power on by sliding the switch to position A and wait for a few seconds. The LEDs light and turn off in rotation.

The operational amplifier works as an astable multivibrator. When the output is low, LED 2 lights; when it is high, LED 1 lights.

You can alter the speed of the blinking by using different values for R and C. See how the speed of the pulses alters when you alter the value of R to 220k $\Omega$ .

### Notes:

### Wiring Sequence:

- 31-36-67-90-94
- 33-70-135
- 34-63-132
- 93-68-113
- 81-89-69
- 82-114-124-119
- 121-134
- 122-131

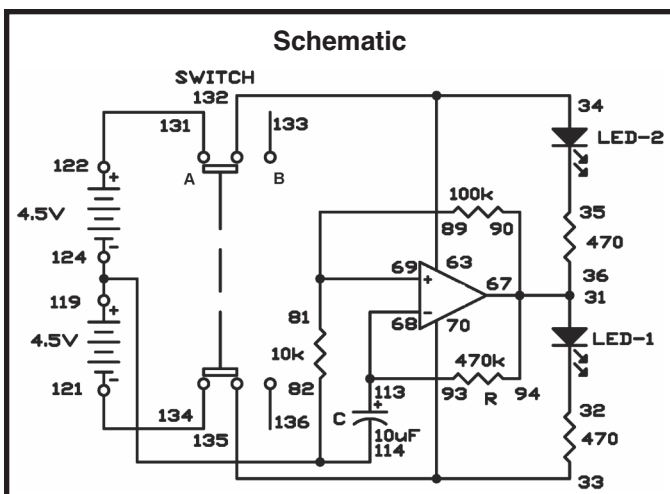

## EXPERIMENT #81: SINGLE FLASH LIGHT

You've built many circuits using the operational amplifier, but there are lots of other ways to use this handy IC. One of them is the single flash multivibrator. With this multivibrator, you can make the LED stay on for a preset amount of time when the key is pressed - a single flash light.

### Notes:

Slide the switch to position B and construct the circuit. Turn the power on by sliding the switch to position A. The LED lights, but quickly turns off. Now, press the key and observe what happens. The LED lights and stays on for 2 to 3 seconds and then turns off.

By using different values for C You can change the amount of time the LED is on. Change the value of C from 10 $\mu$ F to 100 $\mu$ F and see what occurs to the LED. It stays on longer.

### Wiring Sequence:

- 31-63-94-131-138
- 33-67-114
- 85-68-110
- 69-82-89-93
- 70-134
- 81-86-130-124-119
- 90-115
- 109-137-129
- 113-116
- 121-135
- 122-132

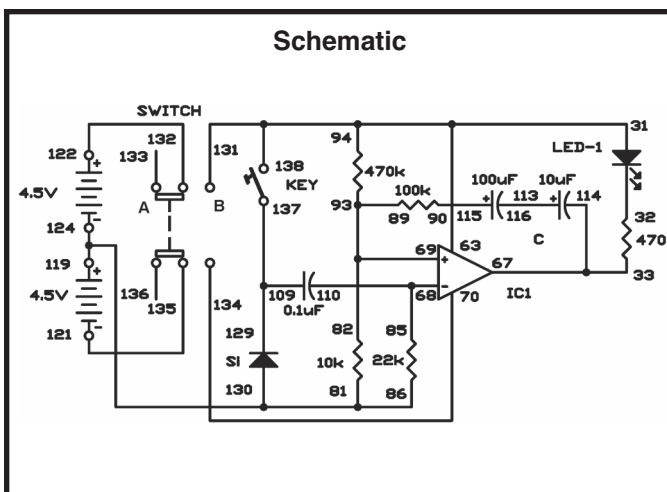

## EXPERIMENT #82: INTRODUCING THE SCHMITT TRIGGER

Now you are going to use the operational amplifier as a comparator and as a Schmitt trigger circuit. As long as its input voltage exceeds a certain value, the operational amplifier will produce a signal. View the schematic: can you see how it works? The input level that turns on the output is higher than the level than turns it off. So once a Schmitt trigger circuit turns on, it stays on unless the input drops significantly. We call this type of operation a “hysteresis loop.”

Build the circuit, but don't press the key yet. The operational amplifier serves as a comparator in this state. When you alternate the control, LEDs 1 and 2 take turns lighting at some point. Note that this point doesn't alter whether you turn the control clockwise or counterclockwise.

Now push the key and you have a Schmitt trigger circuit, which makes a hysteresis loop. Turn the control and see how the circuit operation is different from before.

As the ratio of resistors  $R_B/R_A$  increases, the width of hysteresis becomes narrower. Try using different values for  $R_A$  and  $R_B$ , and notice how the width changes.

### Notes:

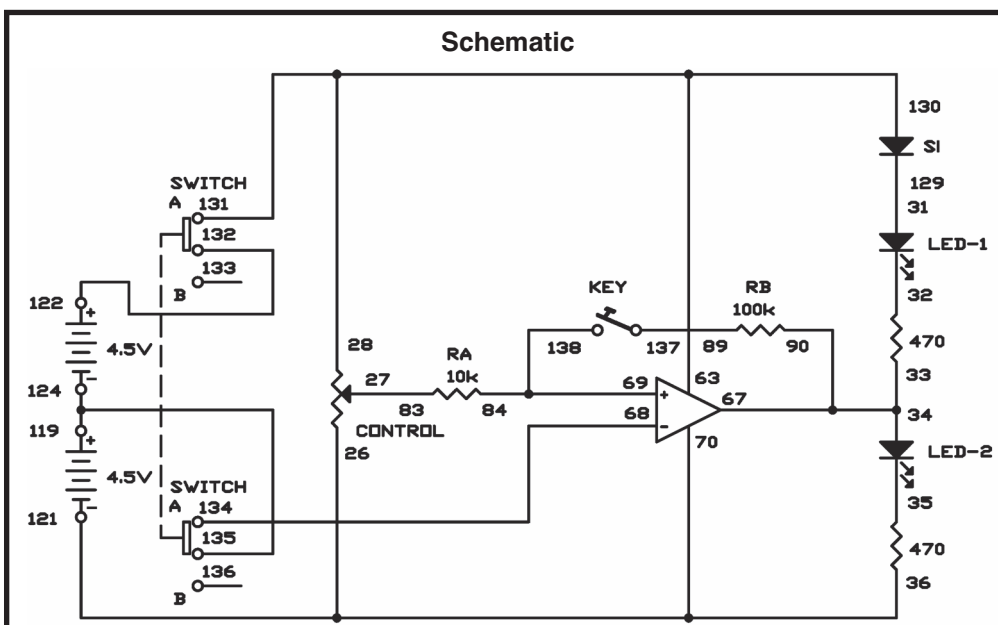

### Wiring Sequence:

- 70-36-26-121
- 27-83
- 63-28-130-131
- 34-33-67-90
- 68-134
- 84-69-138
- 89-137
- 119-124-135
- 122-132
- 31-129

## EXPERIMENT #83: INITIALS ON LED DISPLAY

The digital LED can't display all 26 letters of the alphabet, but it's possible to exhibit many of them. Let's make an LED display that intersperse shows the initials E and P of our ELECTRONIC PLAYGROUND. You can show other initials too.

Slide the switch to position B and construct the circuit. Once you have completed the wiring, slide the switch to position A to turn on the power, and you'll observe the letters E and P lighting alternately on the LED display.

IC 1 works as an astable multivibrator and exhibits the letter E. IC 2 is used as an inverter, with an output that is opposite to that of IC 1; it displays the letter P.

Now that you've successfully displayed the letters E and P, why not try showing other letters? It should be easy if you take a close look at the schematic.

**Notes:**

### Wiring Sequence:

- 22-17-18-19-63-131-81
- 20-65-67-90-94
- 21-64
- 83-114-70-25-121
- 66-69-82-84-89
- 93-68-113
- 119-124
- 122-132

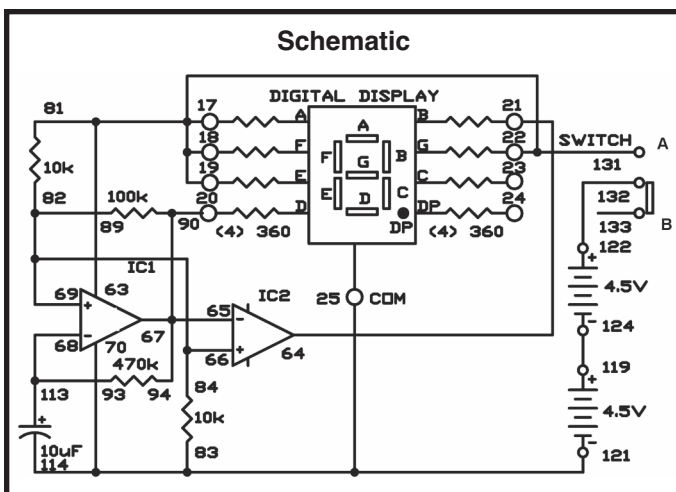

## EXPERIMENT #84: LOGIC TESTING CIRCUIT

You know that digital circuits produce low or high (L or H) outputs (0 or 1). Now you're going to create a logic tester that shows 1 for high level (H) and 0 for low level (L) on the LED display.

### Notes:

Slide the switch to position B and construct the circuit. When you finish the wiring, slide the switch to position A to turn on the power. The number 0 is on the display because the test terminal (terminal 13) is at low level when no input is exerted. Attach the test terminal-to-terminal 122 to apply +4.5V. The display alters to 1.

View the schematic. The operational amplifier works as a comparator. The 22k $\Omega$  and 10k $\Omega$  resistors produce a reference voltage of 3V at its negative (-) input terminal. When the voltage at its positive (+) terminal exceeds this reference voltage, the comparator's output level goes high, turning off transistor Q1. Now segments A, D, E, and F on the display turn off, leaving a 1 on the display.

### Wiring Sequence:

- 17-18-19-20-44
- 86-79-63-21-23-45-132
- 43-80-82
- 67-81
- 68-83-85
- 119-124
- 122-131
- 69-89-13-CHECK POINT
- 121-25-70-90-84-14-CHECK POINT

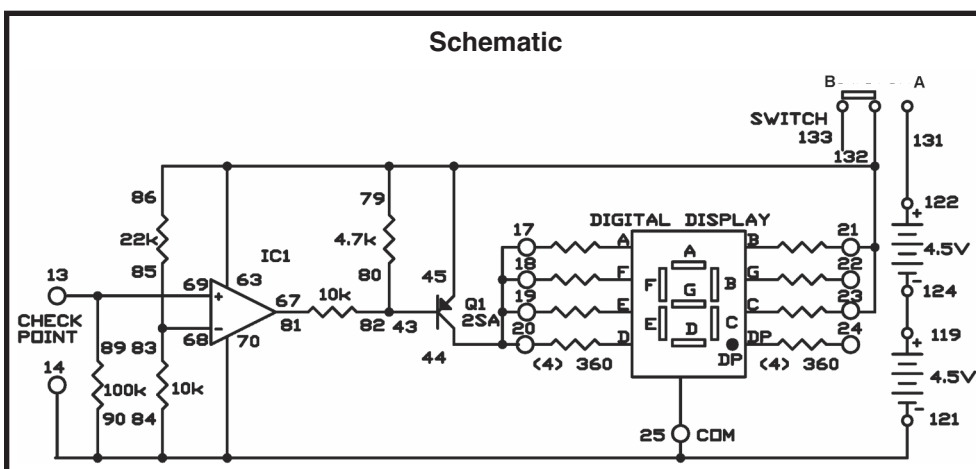

## EXPERIMENT #85: VOICE-CONTROLLED LED

A microphone can be used to detect sound. Here you will make a circuit that lights the LED when the microphone detects sound, using the speaker as a microphone.

Slide the switch to position B and construct the circuit. When you finish the wiring, by sliding the switch to position A to turn on the power. Now talk into the “microphone” (the speaker) or tap it lightly; the LED blinks.

Observe the schematic. IC1 is configured as a non-inverting amplifier with a gain of about 100, and it amplifies the signal from the microphone (the speaker). IC2 is configured as a comparator, comparing the output of IC1 to a reference voltage from the battery. When IC1’s output exceeds the reference voltage, the comparator output goes low, and the LED lights.

**Notes:**

### Wiring Sequence:

- 1-29
- 2-30
- 3-110
- 5-76-74-80-70-121
- 85-31-63-132
- 33-64
- 79-65-112
- 73-86-66
- 90-67-111
- 89-68-115
- 69-109
- 75-116
- 119-124
- 122-131

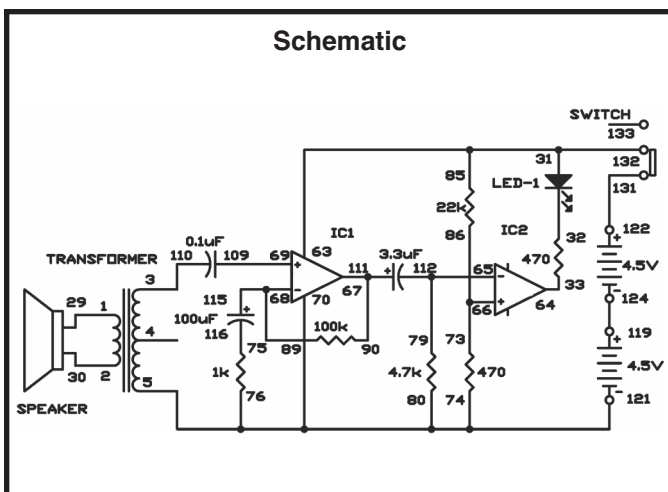



## EXPERIMENT #86: BUZZING WITH THE OP AMP

The operational amplifier (op amp) works well as an oscillator. In this experiment, you will build an electric buzzer that makes a continuous beep. By rotating the control you can change the tone of this buzzer.

When you finish the wiring, set the control to the 12 o'clock position and press the key. From the speaker you hear a continuous beep. Turn the control as you press the key; the tone of the buzzer changes.

The electronic buzzer only makes a beep, but it can be used for many different purposes, as you'll see later.

This circuit is an astable multivibrator working as an oscillator to produce a square wave signal for the speaker. Adjusting the control changes the frequency, so the tone of the sound is different. The frequency is determined by the resistors and capacitor connected to the input terminals of the operational amplifier. Try changing the capacitor to  $0.02\mu\text{F}$  or  $0.1\mu\text{F}$  and see how the tone changes.

### Notes:

### Wiring Sequence:

- 1-29
- 2-30
- 3-116
- 5-84-70-106-121
- 63-27-138
- 28-81
- 67-90-92-115
- 91-68-105
- 69-82-83-89
- 119-124
- 122-137

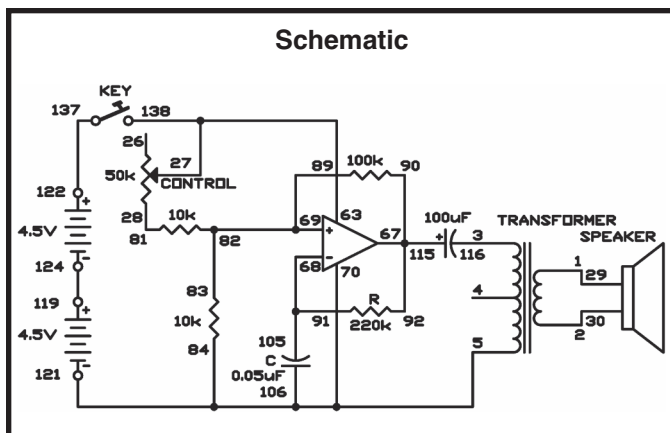

# EXPERIMENT #87: SWEEP OSCILLATOR

The electronic buzzer we built in the previous circuit can only make a continuous beep, but we can make a similar circuit that produces various siren sounds. Your going to make a siren that gives out a sound with a variable pitch. When you move the switch, this siren wails and then creates a continuous high-pitched noise.

Slide the switch to position B and assemble the circuit. When you complete the wiring, turn the power on by sliding the switch to position A. You hear the speaker produce a sudden, roaring siren sound. At first the sound is low and becomes higher, then changes to a steady tone in about 3 to 4 seconds. When you press the key and release it, the capacitor discharges and starts the siren sound again.

You can understand how this works by looking at the schematic. The pitch changes as the 10μF capacitor is charged through the 100kΩ resistor. IC 2 is an astable multivibrator. IC 1 is a buffer between the capacitor and IC 2.

## Notes:

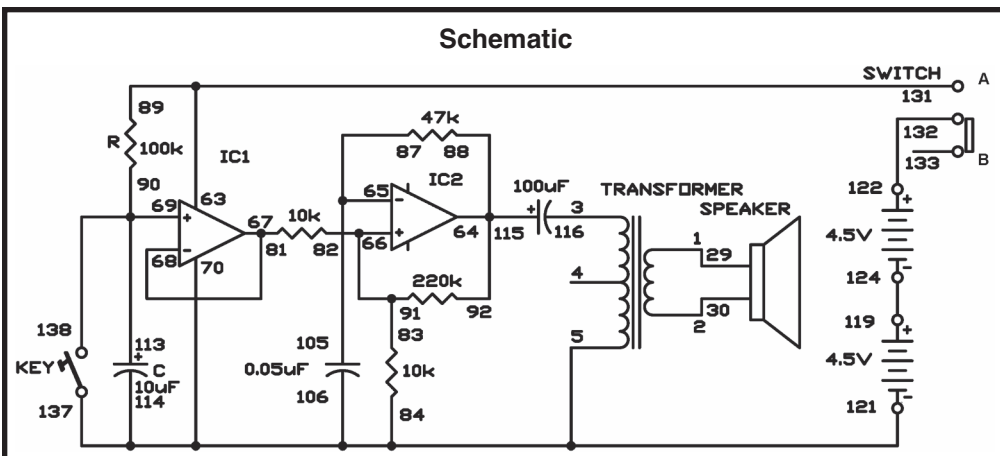

## Wiring Sequence:

- 1-29
- 2-30
- 3-116
- 5-84-70-106-114-137-121
- 89-63-131
- 64-88-92-115
- 65-87-105
- 66-82-83-91
- 68-67-81
- 90-69-113-138
- 119-124
- 122-132

## EXPERIMENT #88: FALLING BOMB

Here's another siren that alters its pitch. The siren we built in our last experiment alters pitch from low to high, but this one alters its pitch from high to low and finally stops making any sound. When it stops, press the key and the siren sound will start again.

Set the switch to position B and put together the circuit. When you finish the wiring, slide the switch to position A to turn on the power. You hear a high-pitched siren sound that becomes progressively lower, it sounds like a falling bomb. Press the key to start the sound again.

Like the siren in our last experiment, this siren uses IC 1 as a buffer and IC 2 as an astable multivibrator. The capacitor C and the resistor R change the pitch of the siren sound. The pitch adjusts slowly when you increase the values of C and R, and adjusts quickly when you decrease their values. Try using the 3.3 $\mu$ F capacitor for C and notice how the pitch changes.

### Notes:

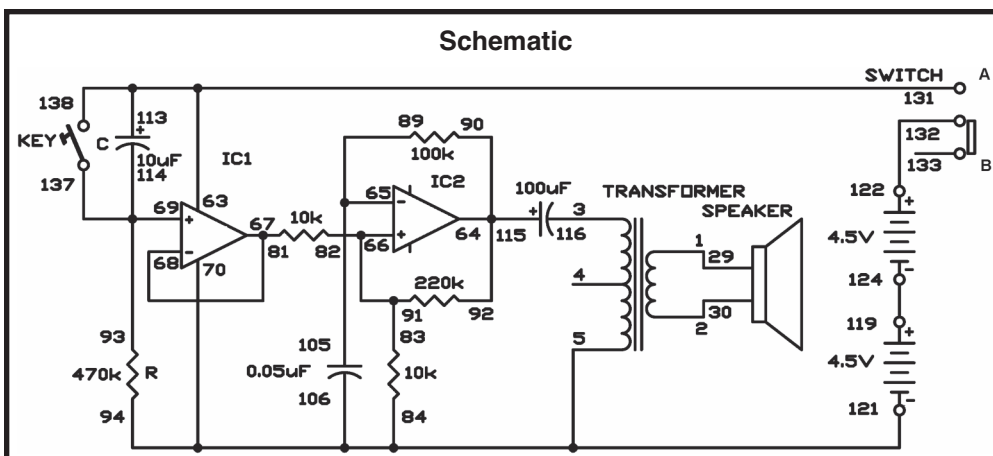

### Wiring Sequence:

- 1-29
- 2-30
- 3-116
- 5-84-94-106-70-121
- 63-113-131-138
- 64-90-92-115
- 65-105-89
- 66-82-83-91
- 68-67-81
- 93-69-114-137
- 119-124
- 122-132

## EXPERIMENT #89: ALERT SIREN

The sirens in Projects 88 and 89 (“Sweep Oscillator” and “Falling Bomb”, respectively) adjust the pitch only in one direction. This circuit makes a low sound that becomes higher, and goes back to its original low sound. The siren sounds only when you press the key.

Set the switch to position B and build the circuit. Turn on the siren by sliding the switch to position A. When you press the key, the siren starts over at the original low pitch. Do you hear the siren sound change pitch? Does it do so as you expected? IC 1 is an oscillator that produces a triangular signal when you press the key. Then the output is sent to IC 2, which acts as an astable multivibrator.

See how the pitch changes when you set C to 0.02 $\mu$ F and then to 0.1 $\mu$ F.

### Notes:

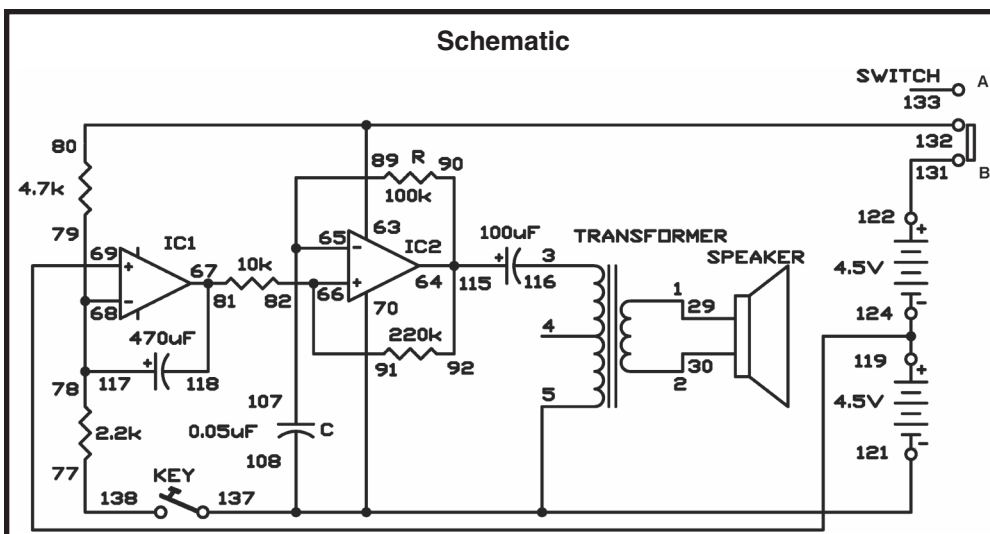

### Wiring Sequence:

- 1-29
- 2-30
- 3-116
- 5-70-108-137-121
- 80-63-132
- 64-90-92-115
- 65-89-107
- 66-82-91
- 81-67-118
- 78-79-68-117
- 69-119-124
- 77-138
- 122-131

# EXPERIMENT #90: CRISIS SIREN

This siren gives off alternating high and low sounds. Slide the switch to position B and construct the circuit. After you complete the wiring and slide the switch to position A, the power turns on and the speaker creates the sound of a two-pitch siren.

This siren is made up of two astable multivibrators. IC 2 provides the normal beep sound. IC 1 produces the signal that alters the pitch of its sound at regular intervals.

Let's execute a small experiment now. The siren gives out an intermittent beep instead of the two-pitch sound once you detach the 22kΩ resistor. Can you decipher why? The IC 1 interrupts the siren sound produced by IC 2.

## Notes:

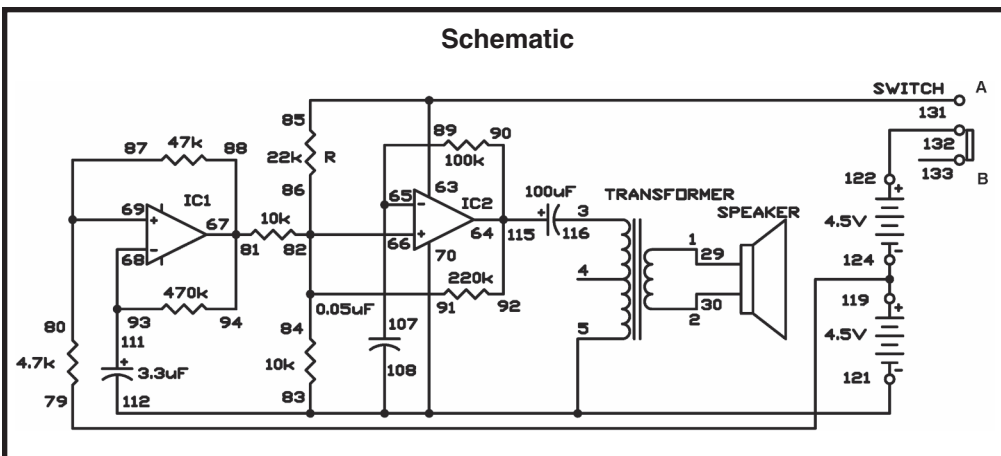

## Wiring Sequence:

- 1-29
- 2-30
- 3-116
- 5-83-70-108-112-121
- 85-63-131
- 64-90-92-115
- 65-107-89
- 66-82-84-86-91
- 81-94-88-67
- 93-68-111
- 69-80-87
- 79-119-124
- 122-132

## EXPERIMENT #91: OP AMP METRONOME

This is the operational amplifier version of the electronic metronome from Project 3 (“Electronic Metronome”). Slide the switch to position B, and connect the wires carefully - this project is more intricate than most of the others. When you complete assembling the circuit, set the control to the 12 o’clock position, and slide the switch to position A to turn on the power. You’ll hear a pip noise from the speaker at fixed intervals. Now gradually rotate the control clockwise, and the beats come faster.

Now observe the schematic. IC 1 and IC 2 are used as astable multivibrators, as in our last experiment. But you’ll notice that IC 1 uses diodes to generate short pulses and the control is used to modify the speed of the pulses. The transistor turns on each time a pulse is generated, and creates a sound.

### Notes:

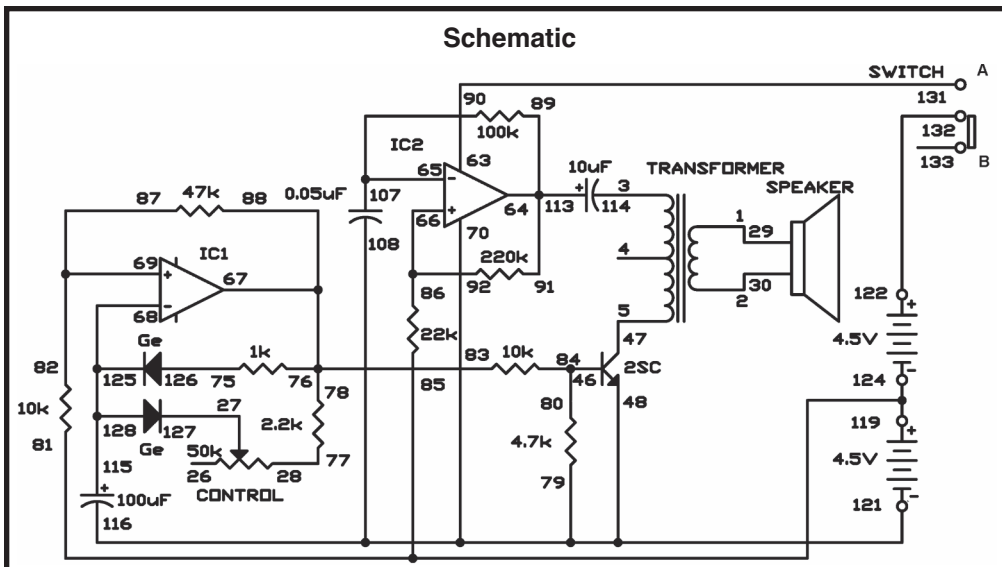

### Wiring Sequence:

- 1-29
- 2-30
- 3-114
- 5-47
- 27-127
- 28-77
- 46-80-84
- 79-70-108-116-48-121
- 63-131
- 89-91-113-64
- 65-90-107
- 86-92-66
- 78-76-83-88-67
- 68-115-125-128
- 82-87-69
- 75-126
- 85-81-119-124
- 122-132

## EXPERIMENT #92: BURGLAR BUZZER

This burglar alarm makes a buzzing sound when anyone sneaking into your house trips over a wire and breaks it off or disconnects it from a terminal. Try to figure out how to connect a switch to the door of your house, so that the alarm sounds when a burglar opens the door, instead of stretching out the wire.

### Notes:

Start by sliding the switch to position B and assembling the circuit. When you complete the wiring, connect the terminals 13 and 14 to the long wire, and slide the switch to position A to turn on the power. No sound comes from the speaker, at this time.

Detach the wire from terminal 13, to test the alarm. The speaker gives out a beep. This beep is the alarm that tells you a burglar is about the break into your house.

As you can observe in the schematic, this burglar alarm uses the operational amplifier as an astable multivibrator, as the electronic buzzer in the last experiment did. You can change its frequency by using different values for the  $10\text{k}\Omega$  resistor and the  $0.1\mu\text{F}$  capacitor. Note how the tone of the buzzer alters when you set the  $10\text{k}\Omega$  resistor to  $47\text{k}\Omega$  or switch the  $100\text{k}\Omega$  and  $220\text{k}\Omega$  resistors with each other.

### Wiring Sequence:

- 1-29
- 2-30
- 3-114
- 5-14-83-70-110-121
- 13-89-68109
- 81-63-132
- 67-90-92-113
- 69-82-84-91
- 119-124
- 122-131
- 13-14 (LONG WIRE)

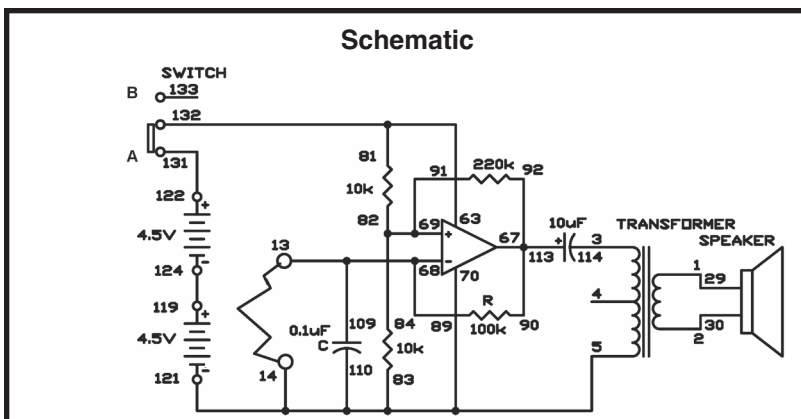

## EXPERIMENT #93: GET UP SIREN

Do you sleep late? Even if you do, don't fear! Because you can make the siren in this circuit alarm so that wakes you up gradually as the day dawns. Set the switch to position B, construct the circuit, then set the switch to position A to turn it on. You should hear sound from the speaker.

When you expose the CdS cell to light, the siren sounds. The siren sound stops when you cover the CdS. The alarm siren is made with a multivibrator, and controls its operation with the CdS.

When you go to bed at night and sleep with your room dark, turn on this circuit. The next morning, the alarm siren will wake you up.

**Notes:**

### Wiring Sequence:

- 1-29
- 2-30
- 3-116
- 5-83-108-70-121
- 15-63-132
- 16-81
- 67-90-92-115
- 91-68-107
- 69-82-84-89
- 119-124
- 122-131

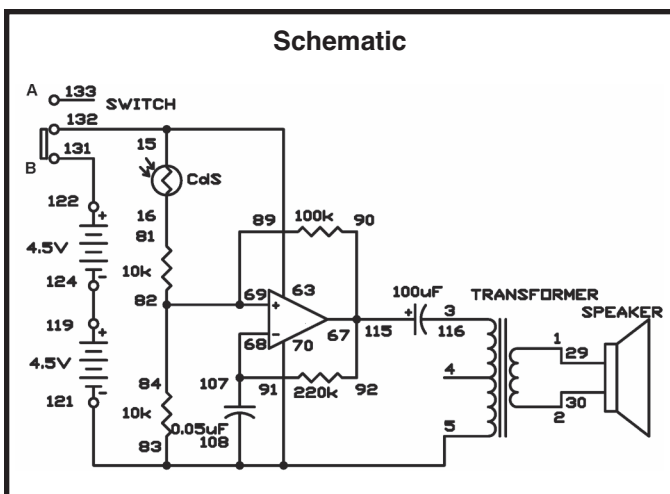



## EXPERIMENT #94: TONE MIXER

Want to create an amplifier that mixes two tones together? There are many different types of tone mixing circuits, but the operational amplifier is considered one of the best.

After you complete the wiring, slide the switch to position A to turn on the power. Note the timbre (the tone) of the sound produced. To mix this tone with another, press the key. You can alter the two separate tones by changing the values for the two  $10\text{k}\Omega$  resistors.

The tone mixer amplifier allows you to mix two tones together by modifying resistances with no need to change the other circuits.

**Notes:**

### Wiring Sequence:

- 1-29
- 2-30
- 3-49-91-119-124
- 5-67-90
- 50-51-85-106
- 52-53-54-87-86
- 55-88-105-113
- 56-57-75-110
- 58-59-60-76-77
- 78-61-109-111
- 62-70-134
- 63-131
- 68-82-84-89
- 69-92
- 81-112
- 83-138
- 114-137
- 121-135
- 122-132

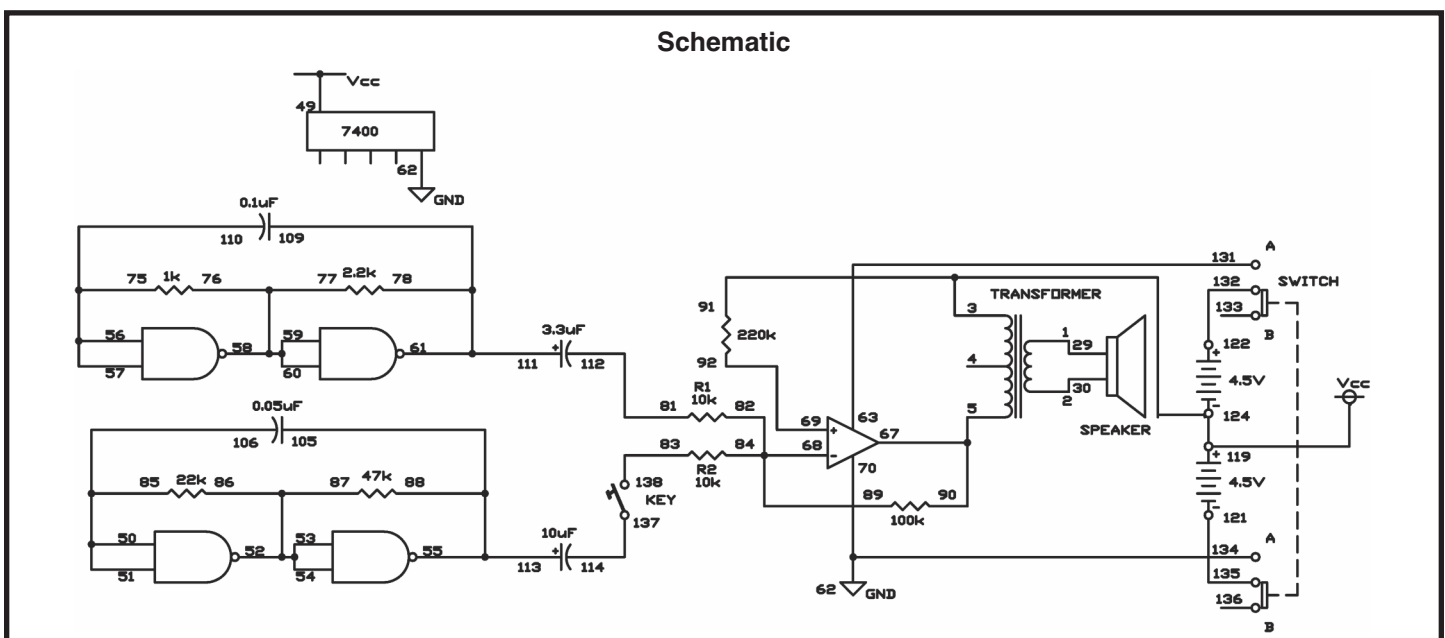

# EXPERIMENT #95: OP AMP POWER AMPLIFIER

Now you are going to produce a loud sound by combining an operational amplifier with two transistors. After you finish the wiring, set the switch to position A to turn on the power. You hear a loud sound from the speaker when you press the key.

### Notes:

A capacitor-resistor oscillator is the signal source for this sound. The operational amplifier acts as an inverting amplifier, and transistors Q2 and Q3 cause the speaker to create the sound. This circuit is called a single ended push-pull circuit (SEPP). You have learned about push-pull circuits. Single ended signifies that the circuit has only one output. Most amplifiers have a second output that is connected to the negative (-) side of the battery.

### Wiring Sequence:

- 1-29
- 2-30
- 3-90-67-47-44
- 5-94-48-119-124
- 73-81-86-87-32-113-45-131
- 33-63-43
- 35-46-70
- 76-92-36-134
- 91-88-104-40
- 75-100-111-41
- 74-114-42
- 68-80-89
- 69-93
- 79-138
- 82-84
- 83-102-103
- 85-99-101
- 112-137
- 121-135
- 122-132

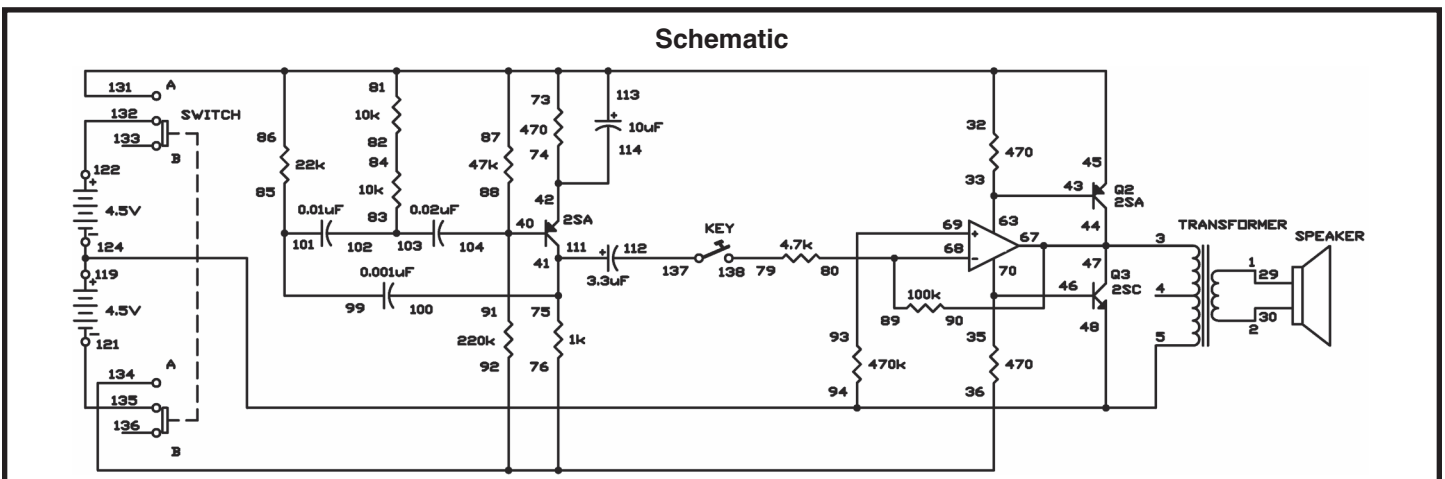

## EXPERIMENT #96: VCO

VCO? What's that? VCO stands for voltage controlled oscillator, and as the name implies, this oscillator changes its oscillation frequency according to the voltage applied to the circuit. The circuit creates two different output signals that have triangular and square waves.

When you finish the wiring sequence, slide the switch to position A to turn on the power. Turn the control slowly while you listen to the sound from the earphone. The sound becomes lower when you turn the control clockwise.

Turning the control changes the voltage at terminal 27, which changes the  $0.01\mu\text{F}$  capacitor's charging and discharging times, which changes the oscillator frequency. The output signal from the first operational amplifier is a triangular wave signal is at terminal 67, and is applied to terminal 65 of the second amplifier. The second amplifier acts as a comparator, and produces a square wave signal at terminal 64.

### Notes:

#### Wiring Sequence:

- 79-63-26-131
- 27-87-89
- 46-91
- 47-76
- 86-92-109-64
- 65-78
- 66-80-83-85
- 67-102-77
- 68-90-101-75
- 69-88-81
- 84-70-134
- 121-135
- 122-132
- 124-119-28-48-94-82-14-EARPHONE
- 110-93-13-EARPHONE

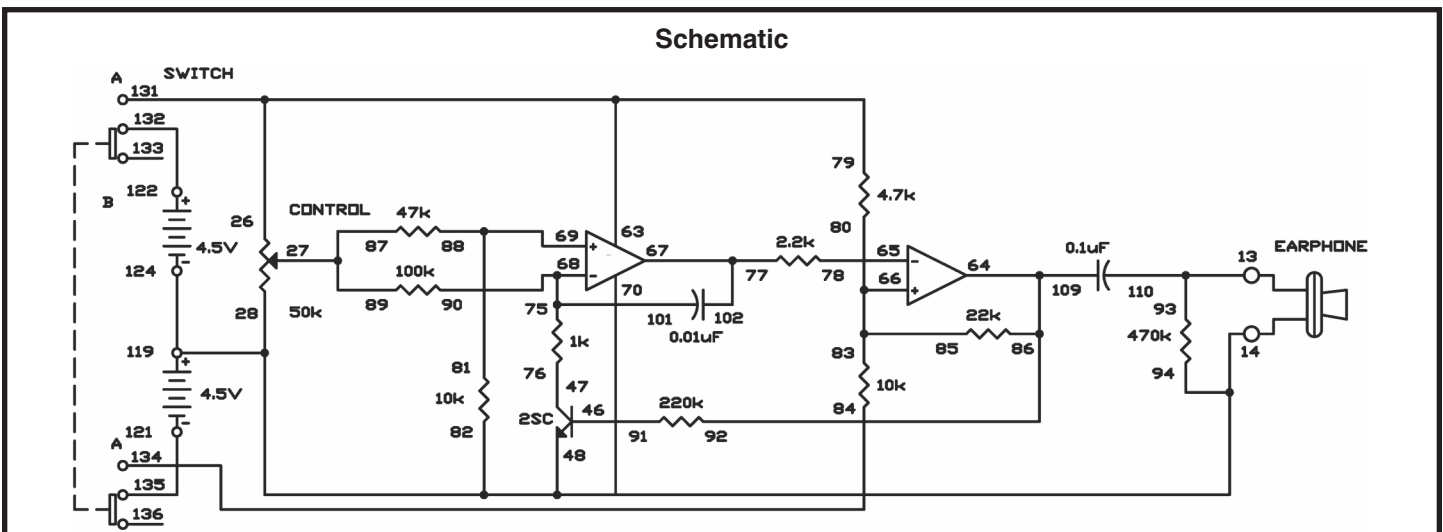

## **IX. MORE FUN WITH OPERATIONAL AMPLIFIERS**

## EXPERIMENT #97: VOICE POWER METER

In this experiment, you will create a voice input power meter. The brightness of the LED in this circuit changes according to the level of voice input that comes from the microphone (the earphone). Since voice levels change quickly, the brightness of the LED should also adjust quickly. In order to show the highest voice input levels, we use a circuit called a peak-level hold circuit. This allows the LED to hold certain brightness after it reaches peak strength, rather than turning off immediately.

Build the circuit, and set the switch to position A. You will use the earphone as a microphone. Speak loudly or blow strongly into the earphone. You can see the LED get brighter temporarily and then gradually grow dimmer.

Study the schematic. You can see that the signal from the earphone travels through the PNP transistor and then becomes the positive (+) input for the first operational amplifier. The output level of the first operational amplifier is stored in the 100mF capacitor, and slowly discharges through the 47kΩ resistor. The LED gets dim as the voltage on the capacitor decreases. The voltage that lights the LED is also fed back to the negative (-) input of the first operational amplifier, where it is compared to the signal from the earphone. If the signal from the earphone is larger, it charges the 100mF capacitor; otherwise there is no output from it.

You can modify the brightness of the LED by changing resistor RA (47kΩ) or the capacitor CA (100μF).

### Notes:

### Wiring Sequence:

- 112-13-EARPHONE
- 119-124-116-33-88-90-80-72-14-EARPHONE
- 31-65-64-82
- 32-71
- 93-111-40
- 79-94-113-41
- 63-42-131
- 87-66-127-115
- 67-129-128
- 81-68-130
- 89-69-114
- 70-134
- 121-135
- 122-132

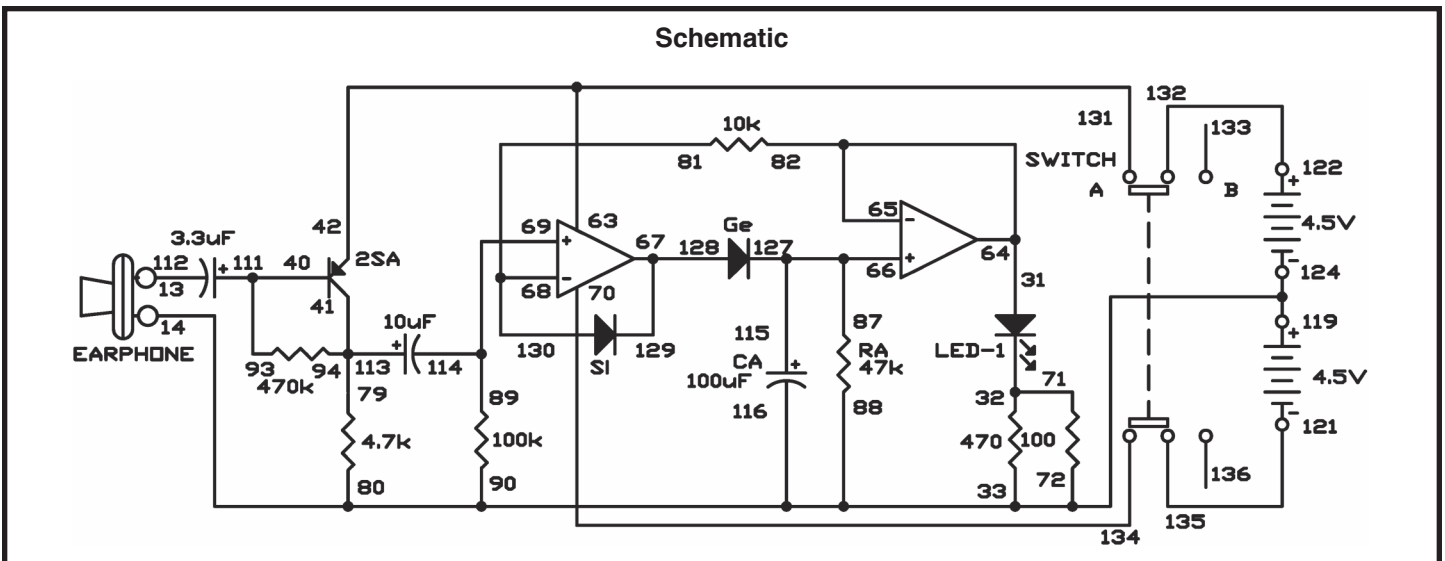

## EXPERIMENT #98: RESET CIRCUIT

Do you know what a reset circuit does? It activates other circuits and detects any power fluctuations in order to prevent malfunctions. In this experiment, we change the supply voltage to the circuit with the switch. The power to the display portion of the circuit is on, or logic high, when the switch is set to position A; it is off when the switch is at position B. When the circuit has been reset the LED display shows 1.

Let's start experimenting. First, finish the wiring and set the switch to position B. Now, with the switch set to B, the power reset circuit operates under 6V, and the three LEDs light dimly. The LED display is off, meaning that the display circuit is not activated.

Now set the switch to position A. You can see the three LEDs light brightly because the supply voltage has been modified to 9V. For a moment, the LED display still shows no change, indicating that the circuit is being reset. After a short interval, the LED displays 1 to show that the circuit has finished resetting and now it is stabilized.

Set the switch to position B to switch the power back to 6V. You will observe the 1 on the LED disappear, because now the display circuit is off.

Study the schematic to understand how the circuit works. The operational amplifier is a comparator. The 3 LEDs are connected together to make a reference voltage of about 5.4V for the negative (-) terminal. With the switch in position B, the positive

(+) terminal receives about 4.1V, so the comparator does not allow the display to light. With the switch in position A, the battery voltage is increased to 9V, and the 100 $\mu$ F capacitor gradually causes the comparator's positive (+) terminal voltage to increase to about 6V. When this voltage exceeds the reference voltage of 5.4V, the LED display lights 1. When you set the switch to B, the voltage at the amplifier's positive (+) terminal discharges through the diode, so the voltage is reduced to 4.1V.

Although this circuit seems very simple (consisting of only one operational amplifier), it is very complex and important for later use.

### Notes:

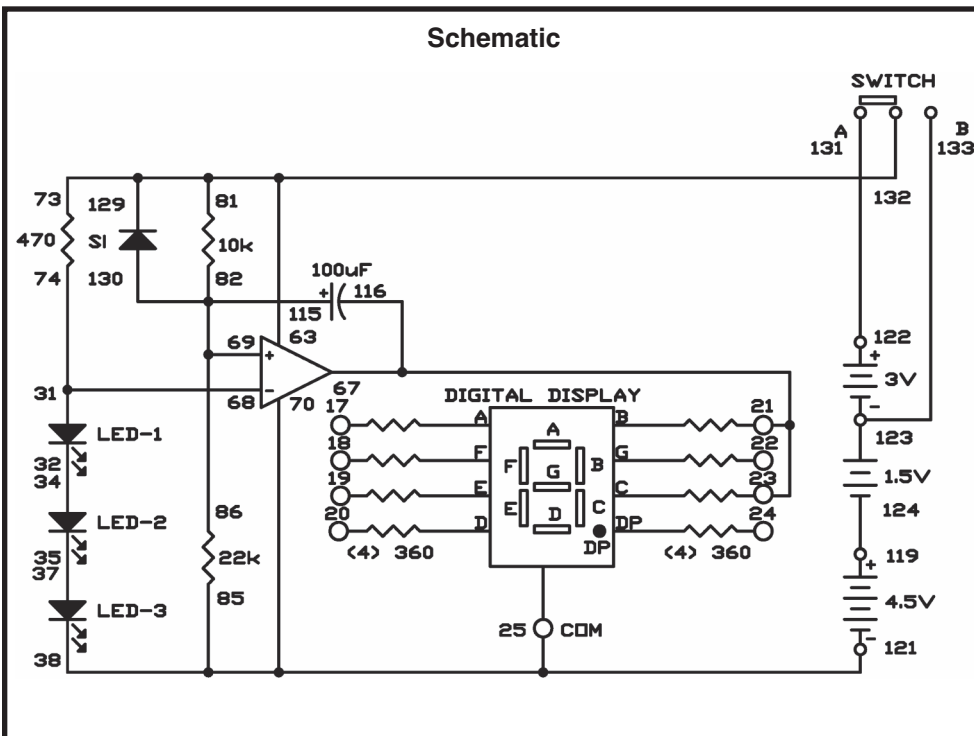

### Wiring Sequence:

- 21-23-67-116
- 85-70-38-25-121
- 31-68-74
- 32-34
- 35-37
- 73-81-63-129-132
- 86-82-69-115-130
- 119-124
- 122-131
- 123-133

# EXPERIMENT #99: RC DELAY TIMER

This circuit is a delayed timer that uses an operational amplifier and the RC time constant. RC stands for resistor/capacitor. A circuit that delays an operation is a time constant.

Through resistors RA and RB the negative (-) terminal of the operational amplifier receives a voltage of about 4.5V. This is the comparator's reference voltage. Connected to capacitor C1 is the positive (+) terminal of the comparator. This capacitor receives its charge through the series resistance of R2 and the control. The charging speed is slower when the resistance is large, and faster when the resistance is small. This charging speed set the delay time for the timer circuit.

Now turn the control fully clockwise to position 10. Set the switch to position A to turn on the power. LED 1 lights first; LED 2 lights about 5 to 7 seconds later. This 5 to 7 second time difference is the delay time that is set by the CR time constant.

Now, turn off the power, set the control fully counter-clockwise to position 1, and see what happens when you turn on the power again. LED 2 lights later than LED 1 again, but how many seconds later?

## Notes:

### Wiring Sequence:

- 81-31-63-27-131
- 28-87
- 83-33-36-70-116-135-121
- 34-67
- 68-82-84
- 88-69-115-136
- 119-124
- 122-132

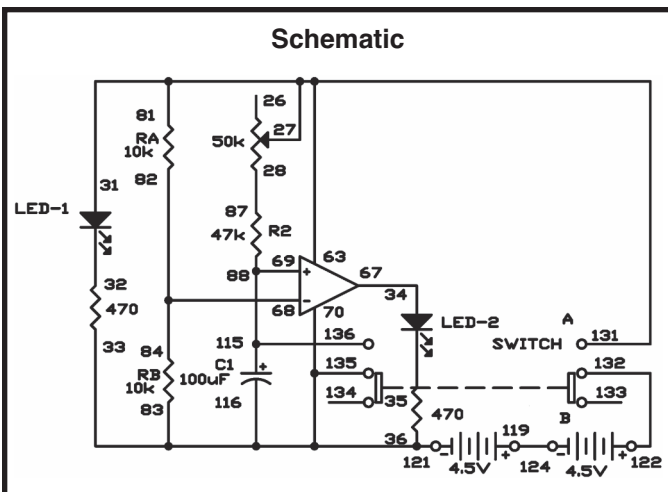

## EXPERIMENT #100: LISTEN TO ALTERNATING CURRENT

The circuit in this experiment allows you to hear alternating current. You probably know that the electric power running through your home is an alternating current. All your appliances that receive power from electric outlets operate on AC- including lamps. Lamps actually flicker at the rate of 60 times per second, but it looks constant because our eyes see after images. In this experiment you will hear sound converted from light.

Ready to start? After constructing this circuit, turn on the power to your kit by setting the switch to A. Place the CdS cell near an electric lamp. Do you hear a hissing sound coming from the earphone? This is the sound of the alternating current. Now place the CdS cell under a fluorescent lamp, and listen for a similar sound.

This circuit greatly intensifies the signals of light on the CdS cell through the operational amplifier. Adjust the quantity of light on the CdS cell with your hand. You can probably hear the volume of the hissing sound reduce and the quality of the sound improve. See what occurs when you expose the CdS to sunlight.

### Notes:

#### Wiring Sequence:

- 15-88-113
- 87-63-131
- 76-93-68
- 70-121
- 69-90
- 75-99-114
- 122-132
- 67-94-81-13-EARPHONE
- 124-119-16-100-89-82-14-EARPHONE

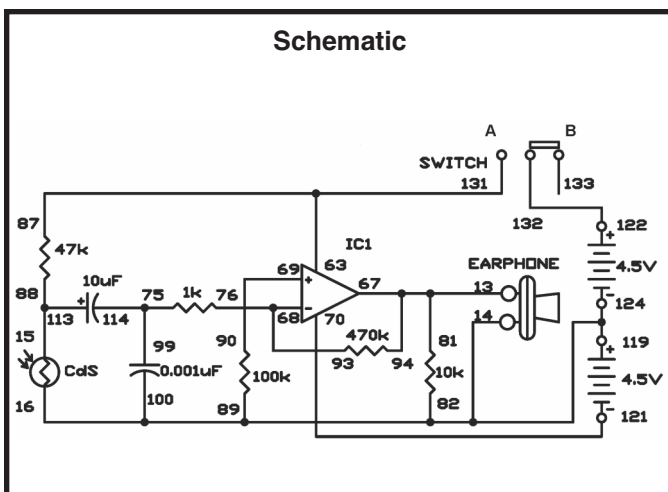



# EXPERIMENT #101: PULSE FREQUENCY MULTIPLIER

This is a pulse frequency multiplier with one transistor. It doubles the frequency of the input signal, so it is also called a pulse frequency doubler.

The operational amplifier IC acts as a square-wave oscillator. The output from the oscillator is an AC signal of about 500Hz.

When you finish the wiring, set the switch to position A to turn on the power. Connect the earphone to terminals 93 and 134 and press the key to listen to the oscillating sound of 500Hz. Note the pitch of the tone.

Now, connect the earphone to terminals 13 and 14 and press the key. Listen through the earphone; this time you hear a sound that is an octave higher than the previous sound. This means the frequency is doubled to 1,000Hz.

How does this work? The operational amplifier is configured as an oscillator. Transistor Q1 receives a signal from the operational amplifier through the transistor's base; the base voltage changes with the oscillations. This result is that opposite phase signals appear at the transistor's collector and emitter - when one signal is at a wave maximum, the other is at the wave minimum. The two outputs from transistor Q1 are applied to diodes Da and Db. The diodes pass through only the positive portion of the waves, so these two signals combine together to produce a doubled frequency. In this circuit, the control is used as a 50kΩ fixed resistor.

### Notes:

### Wiring Sequence:

- 125-127-26-91
- 28-13-EARPHONE
- 134-110-92-80-83-76-14-EARPHONE
- 32-63-87-131
- 33-47-107
- 35-48-105
- 89-36-70-121
- 88-90-103-46
- 81-86-67-137
- 85-68-109
- 69-82-84
- 75-77
- 78-106-128
- 79-108-126
- 94-104-138
- 119-124-135
- 122-132

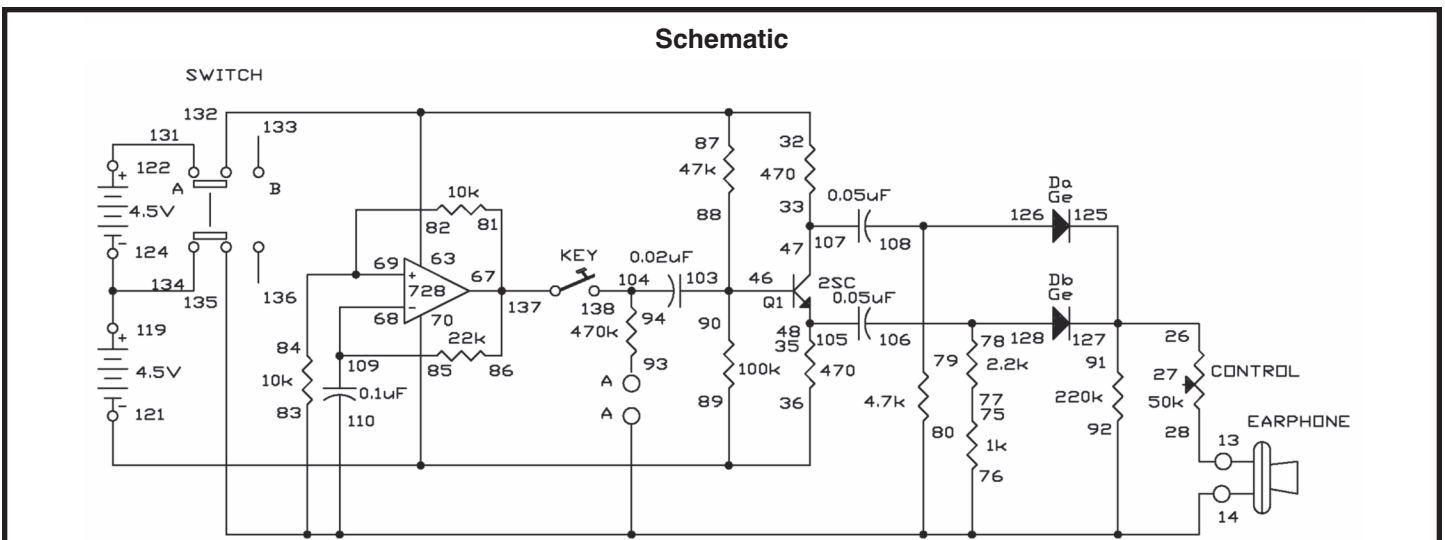

## EXPERIMENT #102: WHITE NOISE MAKER

White noise is a noise that has a wide frequency range. One kind of white noise is the static noise you hear when you tune your FM radio to an area with no station. When you play electronic musical instruments, you can use white noise, a normally useless noise, as a sound source.

### Notes:

When you complete building this circuit, set the switch to position A to turn on the power. Look at the schematic. You will use the noise that is generated when you apply a reverse voltage to the base and the emitter of transistor Q1.

IC 1 acts as an oscillator. The output of this oscillator is rectified by diodes D1 and D2, and flows to Q1. IC 2 amplifies the noise so that you can hear it through the earphone. In this circuit, the control is used as a 50kΩ fixed resistor.

### Wiring Sequence:

- 26-64-90
- 28-13-EARPHONE
- 121-114-112-46-47-70-96-84-85-14-EARPHONE
- 93-48-101
- 94-111-127
- 82-88-63-132-126
- 76-89-65
- 113-66-81-83
- 77-91-67-110
- 68-95-92
- 69-80-87-86
- 78-79
- 109-128-125
- 119-124
- 122-131
- 102-75

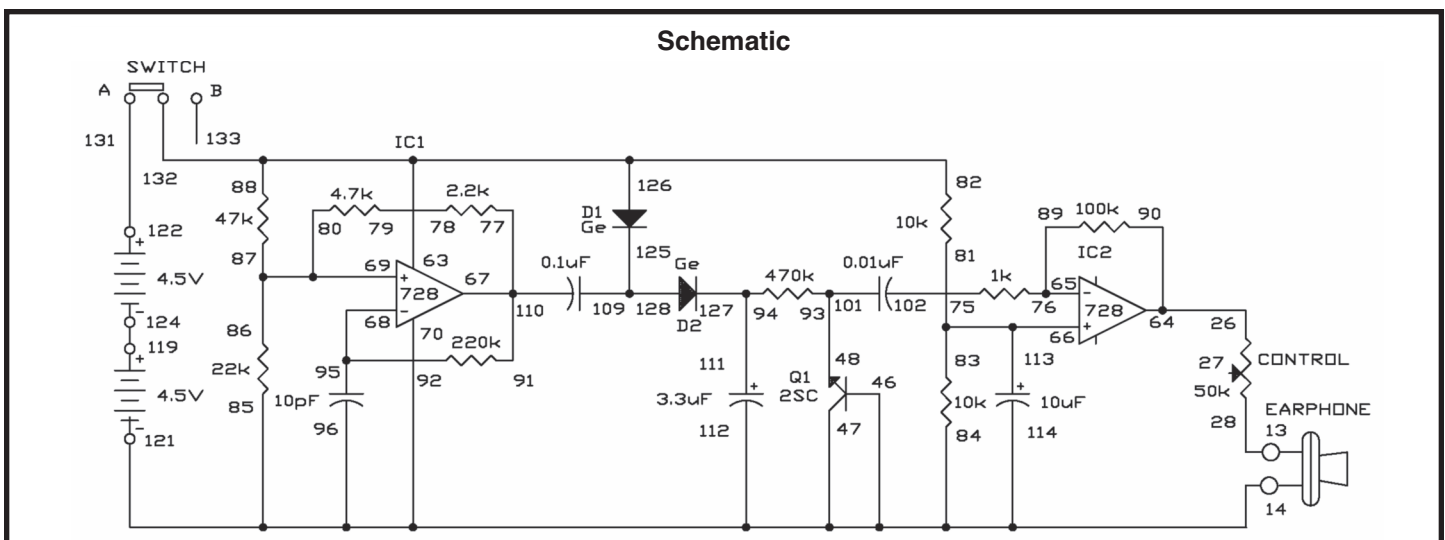

## EXPERIMENT #103: LIGHT-CONTROLLED SOUND

This circuit changes the intervals between each sound according to the amount of light falling on the CdS cell. The sound changes continuously as you alter the light intensity.

Build the circuit, and set the switch to position A to turn on the power. The speaker makes a sound. To change the sound, move your hand over the CdS.

You can calculate the approximate value of the frequency of the signal by using the equation  $1/2 \times C1 \times R1$ . However, R1, in this project, is the CdS and is not constant. By changing C1 you can change the value of the output frequency. In this experiment, another operational amplifier is used as a buffer, so the light-controlled sound part of the circuit is not affected by the speaker sound.

### Notes:

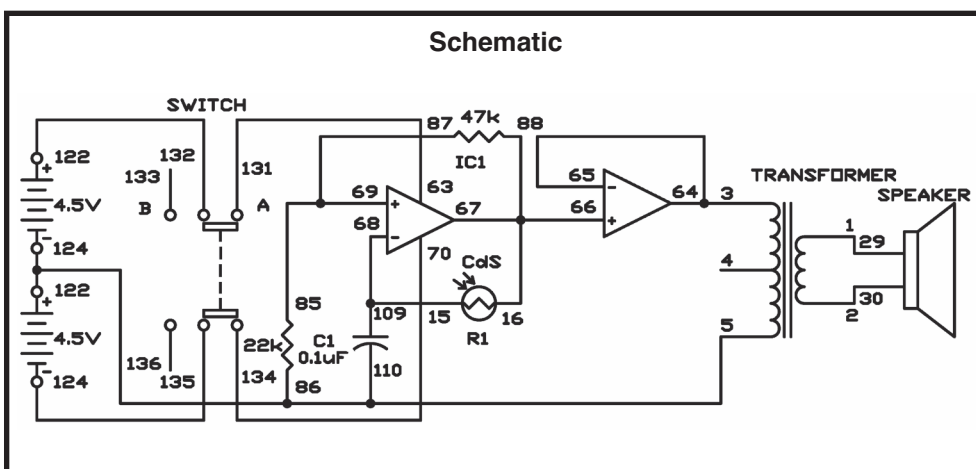

### Wiring Sequence:

- 1-29
- 2-30
- 3-64-65
- 5-86-110-119-124
- 15-68-109
- 16-66-67-88
- 63-131
- 69-87-85
- 70-134
- 121-135
- 122-132

## EXPERIMENT #104 DC-DC CONVERTER

Here's a DC-DC converter circuit; it can make 5VDC from 3VDC. Assemble the experiment, set the switch to position A, and see how this circuit works.

The schematic shows how it works. IC 1 is an oscillator; its output controls transistor Q1. Self-induction of the transformer coil generates a high voltage current. Diode D1 rectifies this voltage and passes on a high DC voltage current. IC 2 is a comparator that examines the voltage. When the input voltage to IC 2 is more than 5V, the LED lights.

How does turning the control affect the circuit? The control is used as a fixed resistor of 50k $\Omega$ , so turning the control has no effect.

Notes:

### Wiring Sequence:

- 3-134
- 5-47-130
- 26-67-72-81
- 28-69-90-92-94
- 31-64
- 33-76-83-86-93-91-70-106-116-48-120
- 46-71-75
- 89-88-63-131
- 84-87-65
- 85-66-115-129
- 82-68-105
- 119-124-135
- 122-132

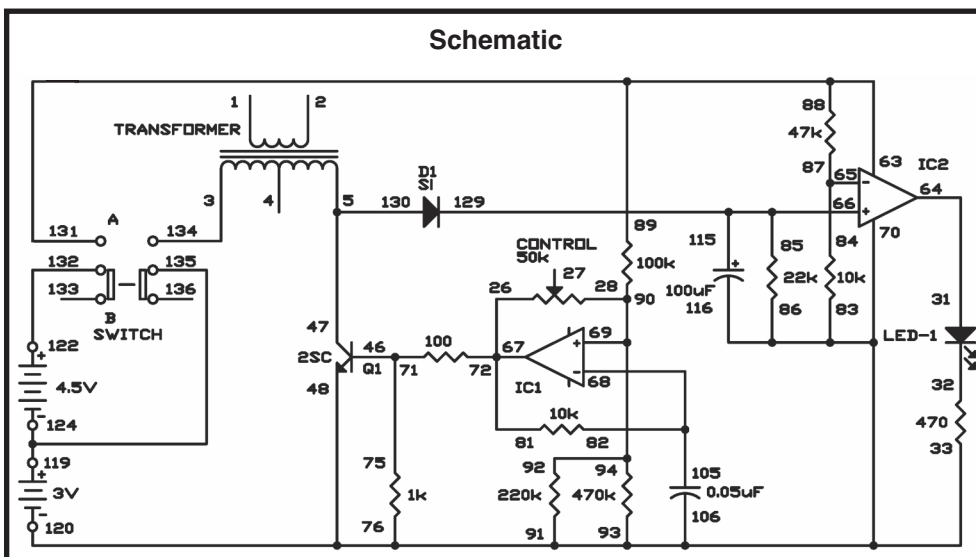

# EXPERIMENT #105: SUPER SOUND ALARM

This circuit produces light and sound when it detects your voice or any other sound. The earphone acts as a microphone. IC 1 amplifies sounds picked up by the microphone. Diodes Da and Db rectify the amplified signal - that is, they convert the sound signal from AC to DC. The signal travels through IC 2, the comparator, and activates the LED and the speaker.

When you complete the circuit, rotate the control fully counter-clockwise, and set the switch to position A. Then rotate the control clockwise while speaking into the microphone, and set the control in a position where the LED only lights when you speak into the microphone. Stop speaking and the LED turns off.

Now disconnect the wire between 57 and 62, and reconnect it between 57 and 32. See what happens to the speaker and LED when you blow into the microphone (earphone).

## Notes:

### Wiring Sequence:

- 75-63-28-131
- 29-76
- 30-47
- 31-64
- 46-86
- 56-77-110
- 58-59-60-79-78
- 85-80-61-109
- 66-83
- 67-90-73
- 68-89-71
- 87-69-113
- 74-111
- 84-91-115-127
- 112-129-128
- 49-50-51-53-54-135
- 114-13-EARPHONE
- 122-132
- 27-65
- 57-26-121-130-48-116-70-92-88-62-33-72-14-EARPHONE
- 119-124-134

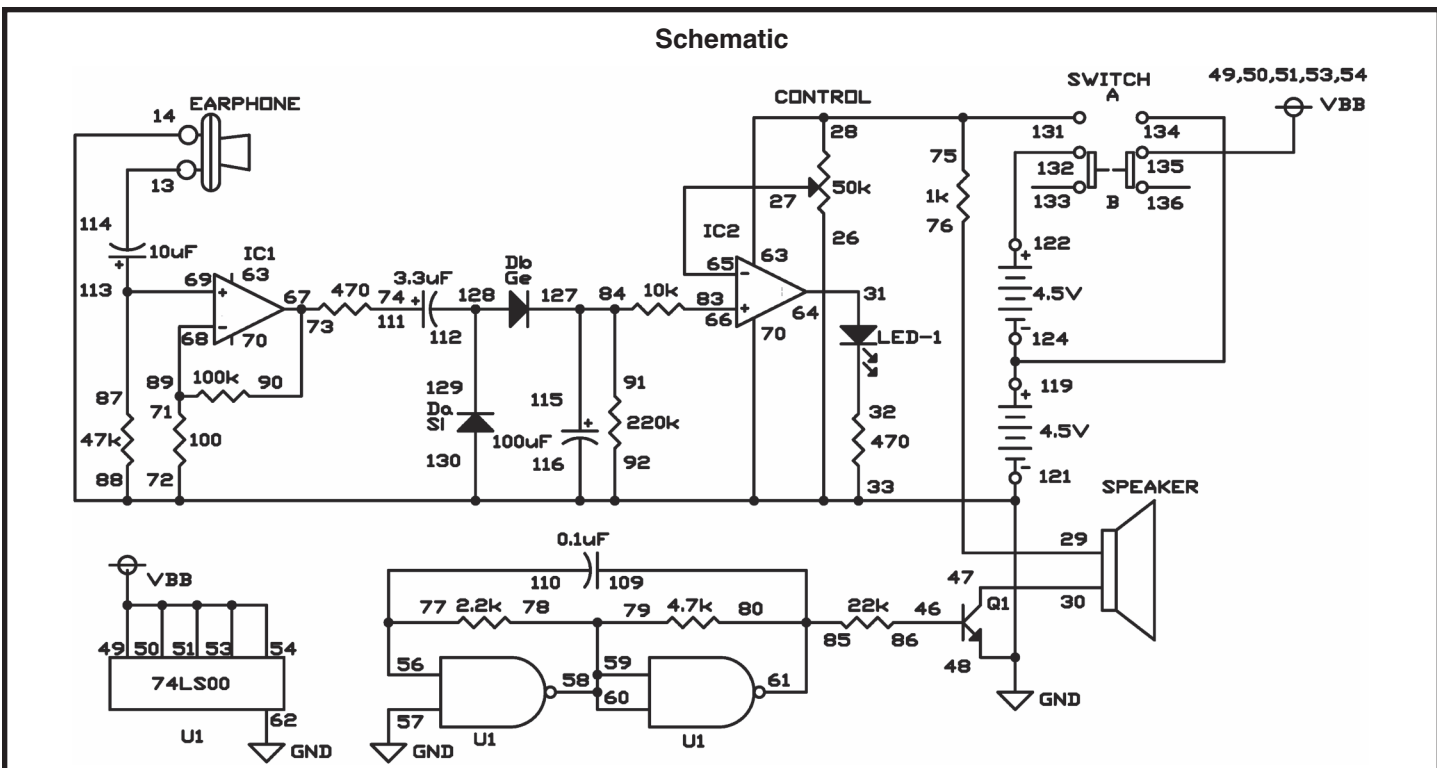

## EXPERIMENT #106: OP AMP THREE-INPUT "AND" GATE

Who says an operational amplifier (op amp) can't be used to make a digital circuit? Here, you will use one to make an AND gate. The LED display is the output device. If it displays nothing, at least one of the output signals is logical 0 or low; if it displays H, they are all logical 1 or high.

### Notes:

When you finish the wiring, turn on the power by setting the switch to position A. The LED remains dark. The input terminals are 125, 127, and 129. These terminals are connected to the negative (-) terminal, so they do not cause the LED to light. Terminal 14 is connected to the positive (+) terminal, so it is the logic 1 terminal. When you connect terminals 125, 127, and 129 to terminal 14 in various combinations, you see that the LED lights and shows H only when terminals 125, 127, and 129 are all connected to terminal 14 - logic 1.

### Wiring Sequence:

- 14-85-81-63-19-18-21-22-23-132
- 25-47
- 46-88
- 78-76-83-80-70-48-121
- 67-87
- 68-82-84
- 86-69-126-128-130
- 129-75-WIRE
- 127-77-WIRE
- 125-79-WIRE
- 119-124
- 122-131

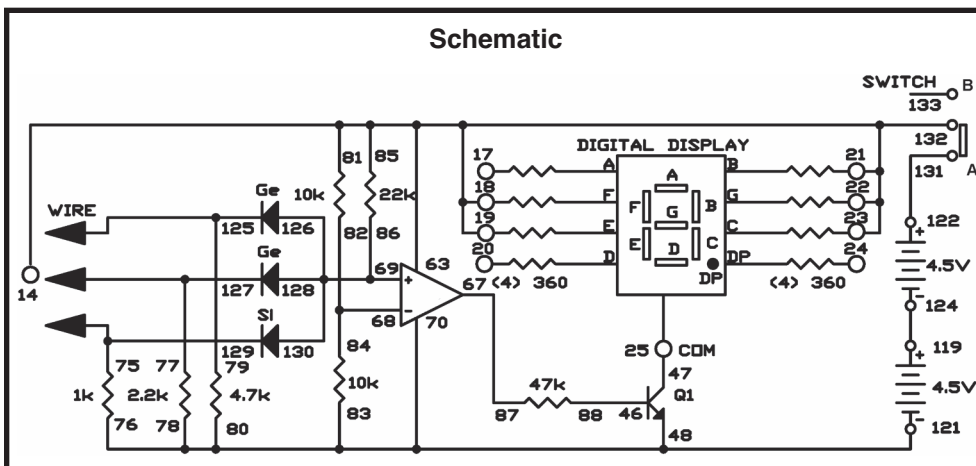

# EXPERIMENT #107: TIMER

Here's a timer you can use for taking timed tests or simply for knowing when an amount of time has passed. You can preset this timer for up to approximately 15 minutes. When the time is up, it gives out a continuous buzzer sound until you turn off the power or press the key to reset the circuit.

After you build this experiment, set the control to position 2 on the dial and slide the switch to position A to turn on the power. Hold a stopwatch and start it when you press the key. The timer makes a buzzing sound in about 30 or more seconds.

Set the control to each division on the dial from 2 to 8, and note how long it takes the timer to produce a sound. Setting the timer's calibration - the time that passes at each setting of the dial - requires a lot of patience, but it is necessary for making sure your timer works accurately. After you set the calibration, you need to make a graph showing each control position and the time it takes for the buzzer to sound. Then your tester is ready for use.

Scan the schematic. The control changes the reference voltage of the comparator (IC 1). The resistor R and the capacitor C determine the timer setting. When the voltage applied to the positive (+) terminal of IC 1 exceeds the reference voltage, the alarm sounds.

The operational amplifier has high input impedance (input resistance), so its current loss is very small, and you can use it to make a timer with a very long setting. IC 2 works as an astable multivibrator that produces the buzzer sound.

## Notes:

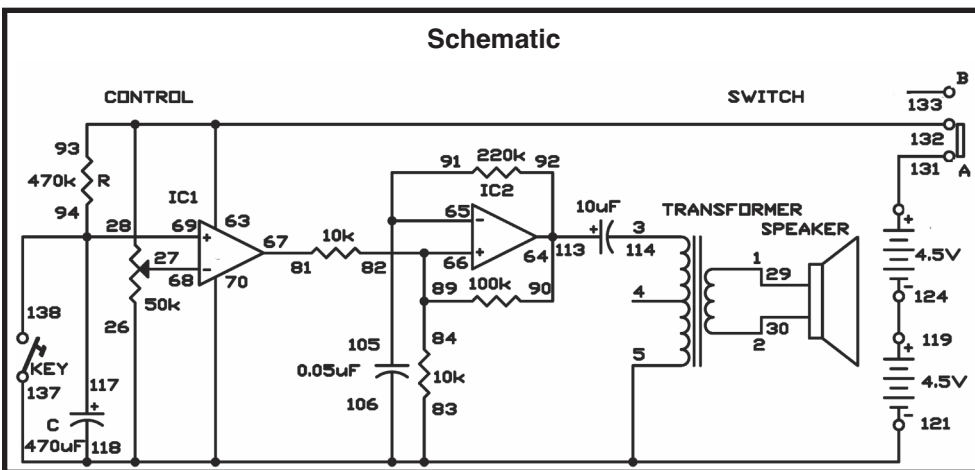

## Wiring Sequence:

- 1-29
- 2-30
- 3-114
- 5-83-70-106-118-137-26-121
- 93-63-28-132
- 92-90-64-113
- 65-105-91
- 66-82-84-89
- 67-81
- 94-69-117-138
- 119-124
- 122-131
- 27-68

## EXPERIMENT #108: COOKING TIMER

Wouldn't you like to make a kitchen timer that you can use for cooking meals? This circuit gives out a buzzer sound for 1 to 2 seconds and automatically stops.

Slide the switch to position B, build the circuit, and set the switch to position A to turn it on. Set the control to position 2 on the dial, and press the key to start the timer. After about 40 seconds, the timer sounds for 1 to 2 seconds and stops. Use the graph you made in project 107 to preset this timer.

Look at the schematic. When the preset time is up, the comparator (IC 2) sends out an output. After a time lag of 1 to 2 seconds produced by R and C, the transistor Q1 turns on to stop the multivibrator. The silicon diode discharges C and restores the circuit to the original state when the timer is restarted.

Notes:

### Wiring Sequence:

- 1-29
- 2-30
- 3-114
- 5-83-70-104-116-118-137-48-26-121
- 27-68
- 93-63-28-131
- 46-85
- 91-103-65-47
- 92-88-64-113
- 81-84-87-66
- 67-82-89
- 69-94-117-138-129
- 86-90-115-130
- 119-124
- 122-132

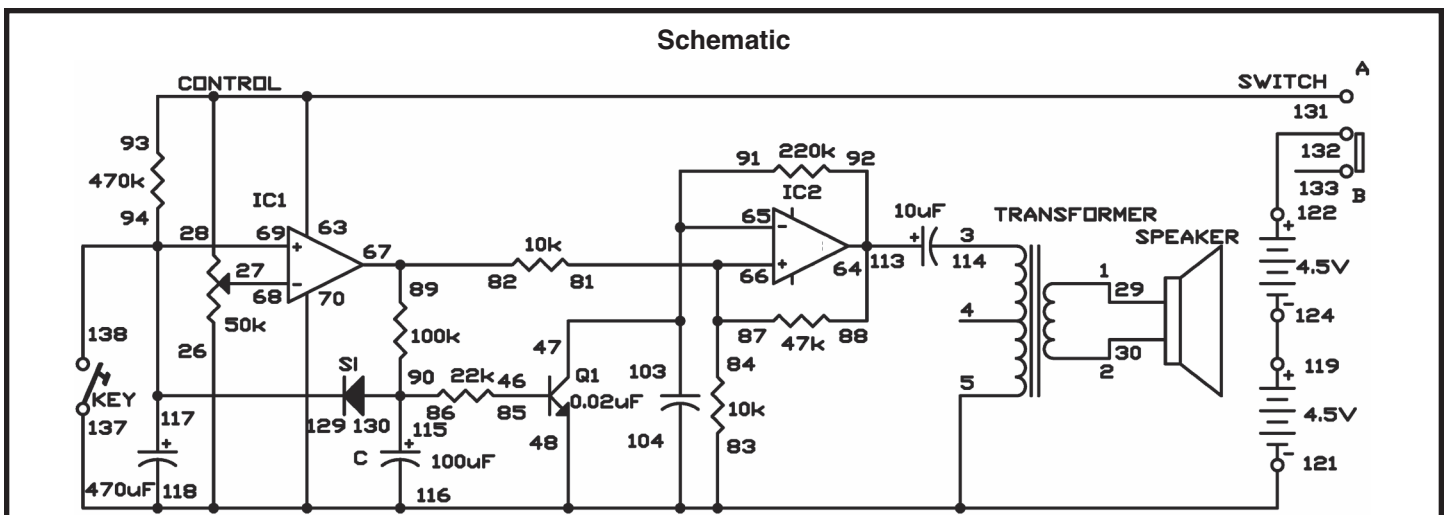



# **X. RADIO AND COMMUNICATION CIRCUITS**

# EXPERIMENT #109: OPERATIONAL AMPLIFIER AM RADIO

In emergency situations when there is no power, a germanium diode radio can be used. Generally they do not perform well and limited to using and crystal earphone since they have no power source.

In this circuit, we will use an operational amplifier so you can hear the radio through the speaker. This simple IC radio uses the dual operational amplifier as a two-power source, non-inverting amplifier.

Slide the switch to position B and assemble the experiment. After wiring the circuits put up the antenna and connect it to the circuit. Set the control to the 12 o'clock position and slide the switch to position A to turn on the power. Turn the tuning capacitor until you hear a station. You can try picking up weaker stations, by using the earphone in place of the speaker in connections to terminals 1 and 2.

### Notes:

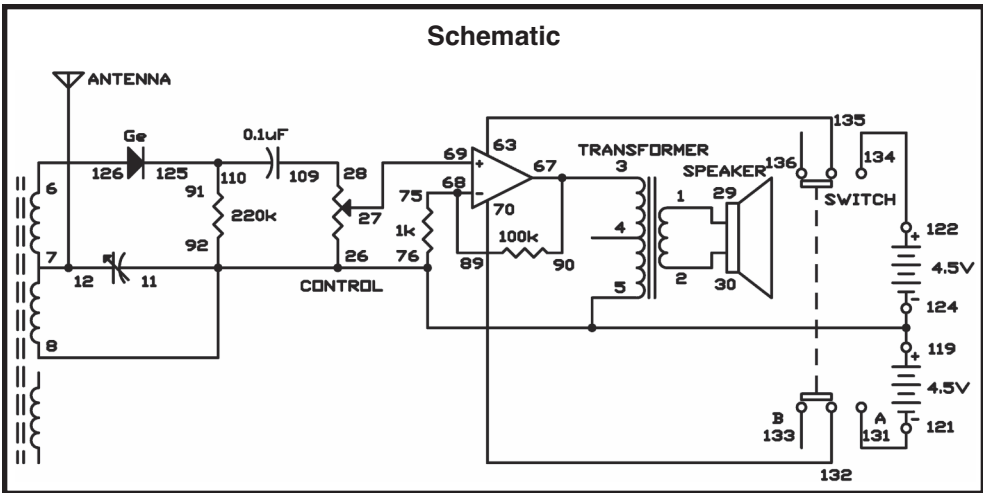

### Wiring Sequence:

- 1-29
- 2-30
- 3-67-90
- 5-8-11-76-92-26-119-124
- 6-126
- 7-12-ANT
- 27-69
- 28-109
- 63-135
- 68-89-75
- 70-132
- 91-110-125
- 121-131
- 122-134

Note: The ANT is the 3-meter long green wire. Connect the one end of the wire to the spring and hang the wire up vertically.

## EXPERIMENT #110: AM CODE TRANSMITTER

This circuit is a simplified but effective code transmitter similar the kind used by military and amateur radio operators around the world. As the key is pressed and released, the transmitter turns on and off in sequence.

### Notes:

The code send out by the transmitter can be received using an AM radio. The radio should be tuned to a weak station. When the transmitter signal mixes with the station's signal it produce an audio tone, called a beat note. The code signal transmitted is the beat note you hear on the radio. Use the tuning capacitor to tune this transmitter until you can hear the beat note in the radio when you press the key.

If your communications receiver has a beat frequency oscillator (BFO), you can receive the carrier wave (CW) signal of this transmitter on a communications receiver, without tuning to another station,. The BFO beats with your transmitter's CW signal and produces the tone.

The frequency of this oscillator sends out an RF signal because is very high (500,000Hz to 1,600,000Hz). Tuning to a weak AM station first, then sending a signal slightly off from the station frequency, you can hear the beat note that you produced.

This type of transmission and reception of CW signals is very efficient and most reliable type of transmission for some emergencies. You might find that you do not need an antenna or only 1- 3 feet (about 60-90 cm) of wire.

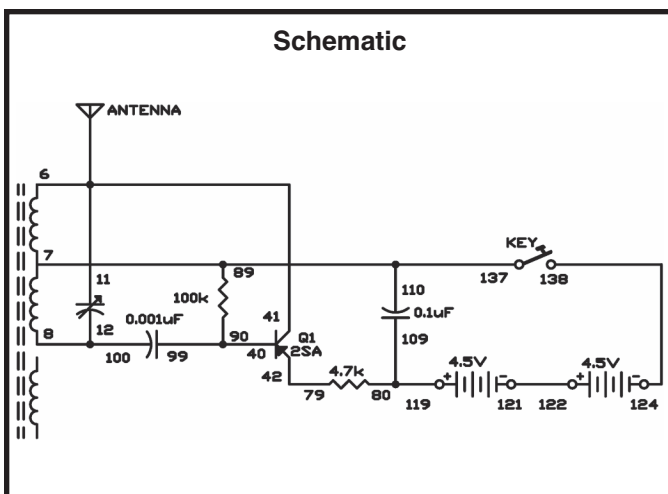

### Wiring Sequence:

- 41-6-11-ANT
- 7-89-110-137
- 8-12-100
- 40-90-99
- 42-79
- 80-109-119
- 121-122
- 124-138

Note: The ANT is the 3-meter long green wire. Connect the one end of the wire to the spring and hang the wire up vertically.

## EXPERIMENT #111: AM RADIO STATION

This AM radio station circuit lets you actually transmit your voice through the air.

### Notes:

When you completed wiring the circuit, tune your AM radio a weak station or place with no stations. Place the AM radio close to the circuit since the signal can only be transmitted a few feet. As you talk into the speaker adjust the tuning capacitor, until you hear your voice on the radio.

The audio signals produced as you talk into the speaker are amplified by transistor Q1. These signals control the amplitude of the RF oscillator signal. The antenna and tuning capacitor tune the RF signal to the setting on your AM radio dial and it is transmitted through the antenna.

The amplitude of the RF signal is controlled by transistor Q2. The RF signal is amplified by NPN transistor (part of the RF oscillator) before the AF (audio frequency) signal modulates it.

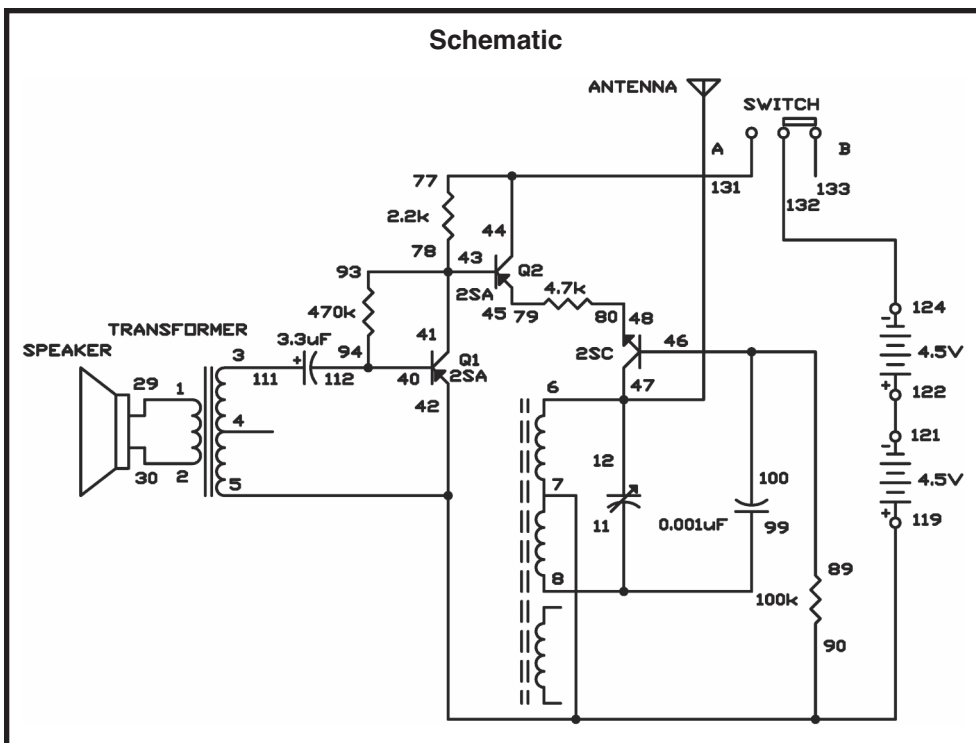

### Wiring Sequence:

- 1-29
- 2-30
- 3-111
- 5-7-90-42-119
- 6-12-47-ANT
- 8-11-99
- 40-112-94
- 41-43-93-78
- 77-44-131
- 45-79
- 89-100-46
- 48-80
- 121-122
- 124-132

Note: The ANT is the 3-meter long green wire. Connect the one end of the wire to the spring and hang the wire up vertically.

## EXPERIMENT #112: CRYSTAL SET RADIO

The crystal radio is one of the oldest and simplest radio circuits, which most people in electronics have experimented with. In the days before vacuum tubes or transistors, people used crystal circuit sets to pick up radio signals.

Since the crystal radio signals are very weak, you'll use a ceramic type earphone to pick up the sounds. These earphones reproduce these sounds well because it is and requires little current.

Necessary for receiving distant stations is a good antenna and earth ground connection is, but you can hear local stations using almost anything as an antenna. A long piece of wire (like the green wire in your kit) makes an acceptable antenna in most cases. When "earth ground" is referenced it means just that; you connect the wire to the ground. You can easily make an earth ground connection by connecting a wire to a metal cold water pipe. If you can also drive a metal stake into the ground and connect the wire to the stake.

Construct the circuit according to the wiring sequence to use your crystal diode radio. The circuit has two antenna connections for either short or long antennas, but only use one at a time. Connect short antennas, 50 feet or less on terminal 95 and longer antennas on terminal 97. Try out each connection and use the one that results in the best reception.

Tank circuit is the part of the radio circuit that includes the antenna coil and the tuning capacitor is called. When a coil and the tuning capacitor are connected in parallel, the circuit resonates only at one frequency. So the circuit picks up only the frequency that generates the tank circuit to resonate. The tuning capacitor alters its capacitance as you rotate it. When the capacitance changes the resonating frequency of the circuit changes. Thus, you can tune in various stations by rotating the tuning capacitor. Without this selectivity, you might hear several stations mixed together (or only a lot of noise).

The tank circuit receives high-frequency RF (radio frequency) signals. The broadcast station uses sound signals to control the amplitude (strength) of the RF signals - that is, the height of the RF wave varies as the sound varies. The diode and the 0.001 $\mu$ F capacitor detect the changes in the RF amplitude and convert it back to audio signals. The conversion of amplitude modulation signal into audio signal is called detection or demodulation.

### Notes:

### Wiring Sequence:

- 6-12-96
- 7-98-126
- 8-11-90-100-EARPHONE
- 89-99-125-EARPHONE
- 95-ANT or (97-ANT)

Note: The ANT is the 3-meter long green wire. Connect the one end of the wire to the spring and hang the wire up vertically.

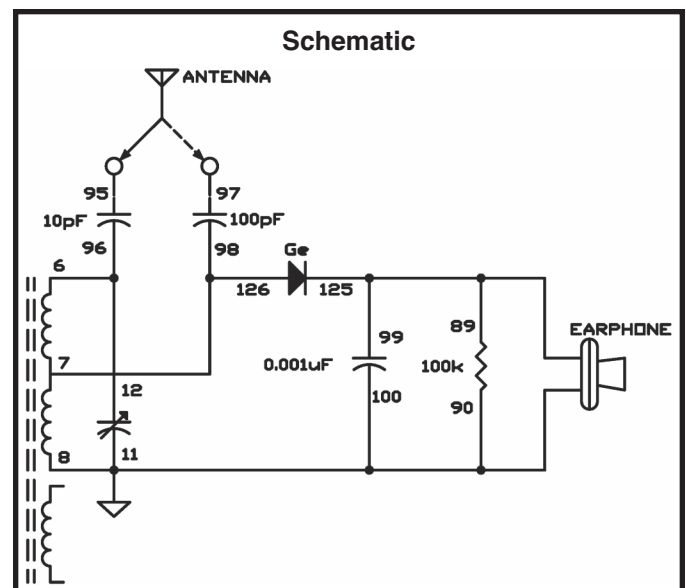

# EXPERIMENT #113: TWO-TRANSISTOR RADIO

This radio circuit uses two-transistor receiver with enough gain (amplification) to drive the speaker. These simple radios require a good antenna and ground system. Wire the circuit and use terminal 74 as the ground terminal. Connect the antenna to terminal 95 or 97. Use the one that gives the best results.

The radio's detector circuit uses a diode and 22kΩ resistor. First, try to use the radio without the 22kΩ resistor by disconnecting the wire from terminal 85. The results are \_\_\_\_\_ (worse / improved) for weak stations and \_\_\_\_\_ (worse / improved) for strong stations.

The basic rules of radio reception are the same as in the last experiment ("Crystal Set Radio"). The tuning capacitor selects the radio station frequency. The diode and 0.02μF capacitor rectify (detect) the audio signal, changing it from AC to DC. Since these signal are very week and must be amplified, so you can hear it through the speaker. Transistor Q1 amplifies the signal first, then the control adjusts the volume, and finally Q2 amplifies the signal again. Finally, the speaker produces the amplified sounds.

## Notes:

### Wiring Sequence:

- 1-29
- 2-30
- 3-44
- 5-72-131
- 6-12-96
- 7-98-126
- 8-11-74-86-88-104-115-117-42-119
- 71-82-116-26
- 27-113
- 28-43-87
- 40-112-91
- 81-92-114-41
- 45-118-73
- 85-103-111-125
- 121-122
- 124-132
- 95-ANT (or 97-ANT)

Note: The ANT is the 3-meter long green wire. Connect the one end of the wire to the spring and hang the wire up vertically.

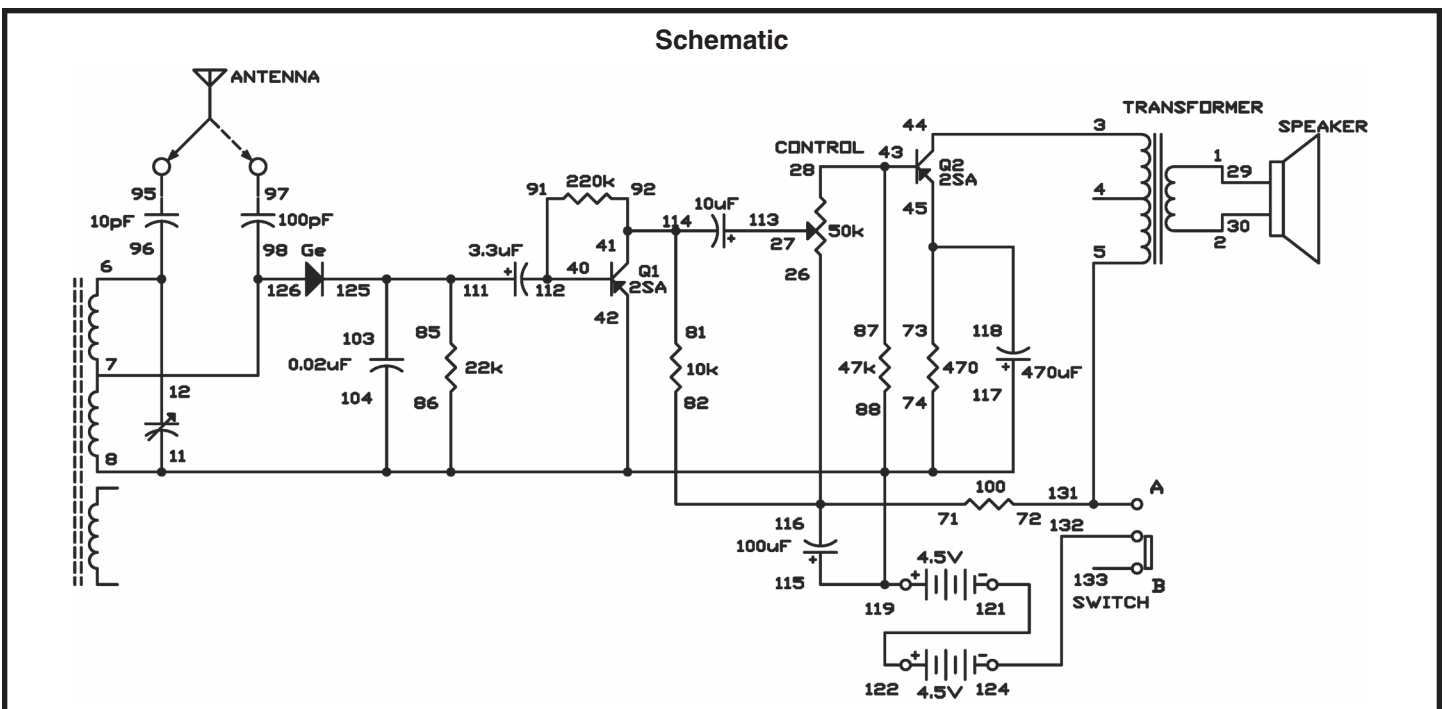

## EXPERIMENT #114: MORSE CODE OSCILLATOR WITH TONE CONTROL

Do you want to become an amateur radio ham? Many radio operators started out using an oscillator with a tone control like this one. Listening to the same tone for a long time can be very tiring, so the tone control in this experiment can be very helpful. Simply connect the wires for this circuit and your code practice oscillator is ready for use.

Morse Code is a code system that uses dots and dashes, invented by Samuel Morse. The most effective way to learn Morse Code is to find someone else who is interested in learning the code. Set up a schedule and practice every day. Create a progress chart so you can see your improvement. Take turns sending and receiving, and it won't be long until the code becomes almost like a spoken language. Operating the key becomes automatic. It takes hard work to get to this point, but you'll be proud when you do.

You can also use different tones to make up your own special code.

If you want to practice by yourself simply use the earphone. Disconnect the speaker and connect the earphone to terminals 27 and 28. Now, the control acts as a volume control as well as a tone control. If you want a fixed tone and volume, just replace the control with a fixed resistance.

When you adjust the control for less resistance, the  $0.05\mu\text{F}$  capacitor charges faster, making the frequency (and the tone) higher. The opposite situation occurs when the control is adjusted for more resistance.

Notes:

### Wiring Sequence:

- 1-29
- 2-30
- 3-87-105-109
- 4-124
- 5-41-110
- 85-106-40-27
- 28-88
- 86-42-137
- 119-138
- 121-122

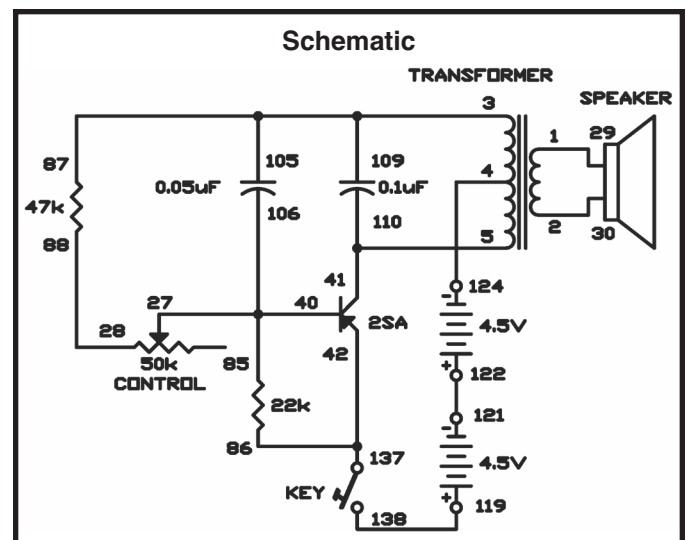

## **XI. TEST AND MEASUREMENT CIRCUITS**



## EXPERIMENT #115: WATER LEVEL WARNING

This experiment uses the LED and an audio oscillator alarm to indicate three different levels of water in a container. The water is used as a conductor to complete the circuits and show the water level.

When the water is below all three of the wire connections, only the bottom segment (D) of the LED is on (indicating a low water level).

When the water is at a level that touches the two long wires connected to terminals 77 and 124 (but is below the shorter wire), the base current turns on transistor Q2 and the middle segment of the LED (G) turns on (indicating a moderate water level).

If the water rises to a level high enough to touch all three wires, the base current is supplied to transistor Q1, and the top segment of the LED (A) lights. The audio oscillator is also activated as a warning of a high water level.

Of course, you can alter this wiring to make the LED display show other letters or symbols to indicate the different water levels. Can you think of any other symbols? (How about L = low, C = center, and H = high?)

### Notes:

### Wiring Sequence:

- 1-29
- 2-30
- 3-103-109
- 4-17-41-87
- 5-47-110
- 20-42-45-119
- 22-44
- 25-48-124-WIRE
- 40-76
- 43-78
- 46-104-88
- 75-WIRE
- 77-WIRE
- 121-122

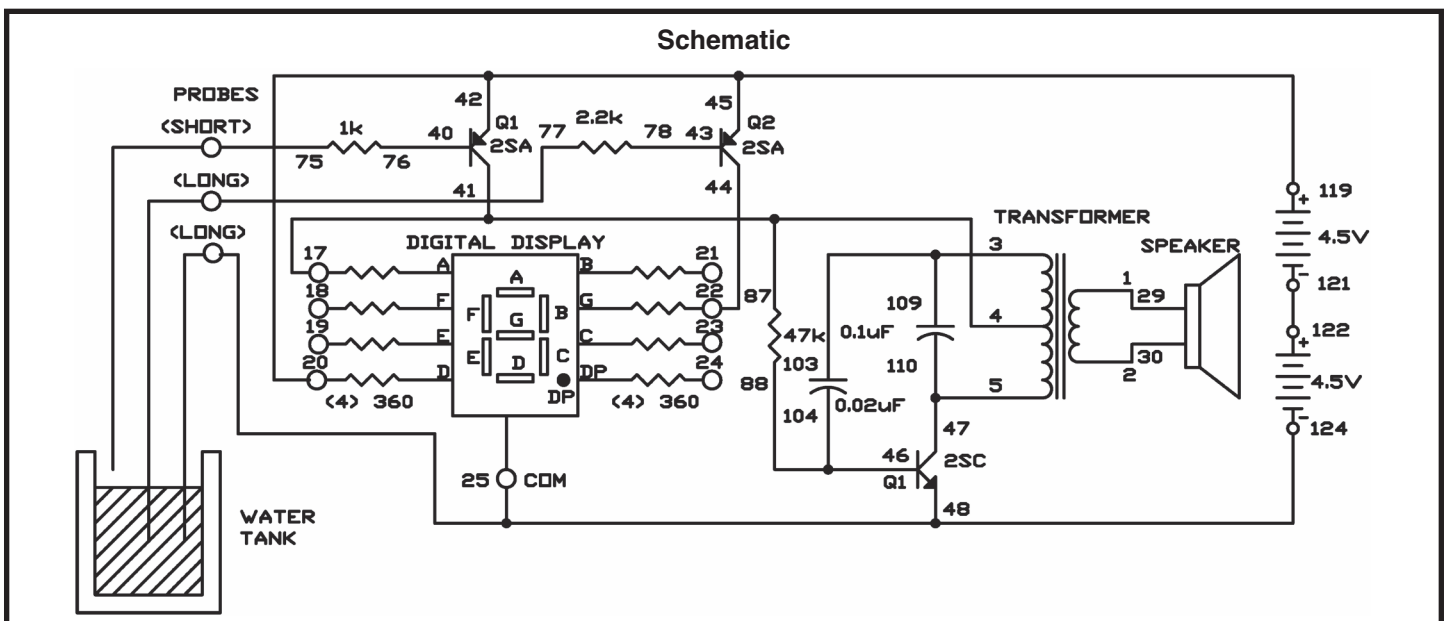

## EXPERIMENT #116: WATER LEVEL ALARM

This circuit is a radio transmitter/alarm for monitoring rising water levels such as on rivers, dams, and spillways, and sends alarm signals to a standard AM radio. When the water-contact plates or wires are out of the water, the circuit is not complete and nothing happens. When the contacts are touching water, the circuit is activated and transmits a radio signal that can be received by a nearby AM radio. When the radio receives the signal, you know that the water level has reached the height of the contacts.

The emitter of the NPN transistor in the radio frequency (RF) oscillator circuit is connected to the ferrite coil center terminal through the 10 $\mu$ F capacitor. The capacitor acts as a short circuit at AM radio frequencies. The radio signal is fed back to the base through the 100pF capacitor. The 470k $\Omega$  resistor supplies the base current that turns on the transistor.

The battery current must flow through the PNP transistor to get to the oscillator circuit and back. When the wires are out of the water, the PNP transistor is turned off, and so is the oscillator circuit.

When the wires are in the water, current flows through the water to supply base current to the PNP transistor, turning it on. This allows current to flow through the PNP transistor's emitter and collector to the oscillator circuit with little resistance. The 47k $\Omega$  resistor limits the current; without it excessive current could burn out the PNP transistor, especially if the probes were accidentally touched directly together.

When the transistor is on, the oscillator produces an RF signal. These probes can be formed of almost any insulated conductor, but large surface areas provide the quickest results.

Place an AM radio receiver nearby and tune it to a weak station. Next, adjust the oscillation frequency with the tuning capacitor to a point where you can hear your water alarm through the radio.

### Notes:

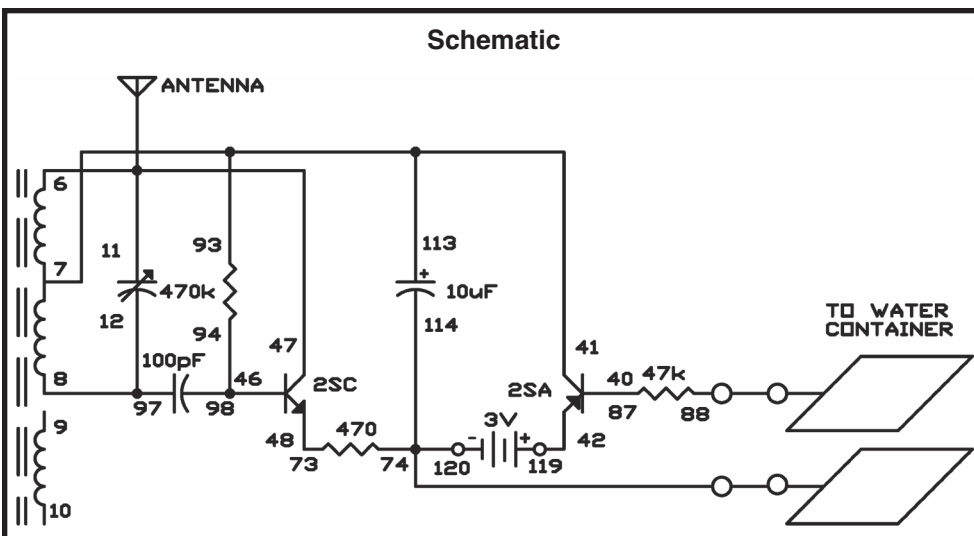

### Wiring Sequence:

- 47-11-6-ANT
- 7-93-113-41
- 8-12-97
- 40-87
- 42-119
- 46-98-94
- 48-73
- 74-114-120-WATER
- 88-WATER

Note: The ANT is the 3 meters long green wire. Connect the one end of the wire to the spring and hang the wire up vertically.

## EXPERIMENT #117: AUDIO SIGNAL HUNTER

This experiment is a simple transistor audio amplifier used as an audio signal tracer. You can use this amplifier to troubleshoot transistor audio equipment. You can connect the wires to different terminals in the circuit until you find the stage or component that does not pass the signal along when a circuit is not working correctly.

The  $0.1\mu\text{F}$  input capacitor blocks DC so you can probe around circuits without worrying about damaging the circuit.

The amplifier circuit is a common-emitter type. The transistor's emitter is connected directly to the input and the output of the earphone. Its base current is the self-current type. The current from the transistor collector provides current to the base (through the  $470\text{k}\Omega$  resistor). This provides some stabilizing negative DC feedback.

You can use this amplifier to check any transistor radio or amplifier you have that needs fixing.

### Notes:

#### Wiring Sequence:

- 46-110-94
- 47-79-93-EARPHONE
- 124-48-PROBES
- 119-80-EARPHONE
- 109-PROBES
- 121-122

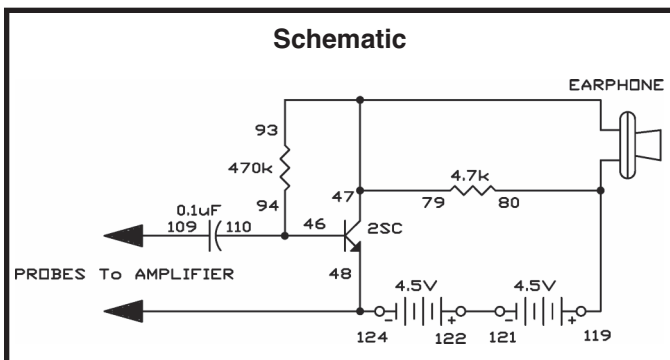

## EXPERIMENT #118: RF SIGNAL TRACER

This experiment is a wide band, untuned RF signal tracer. You can use it to check for antenna signals and find sources of RF noise and interference. This circuit is like an untuned crystal set.

### Notes:

The 100pF capacitor in the input blocks DC and the 60Hz power line frequency, so the wires can touch almost anywhere without fear of electrical shock. Of course, you should never intentionally probe around high voltage.

Attach the probes between grounded objects and other metallic objects that can act as antennas. You will find that this circuit allows you to receive all kinds of AM signals as well as noise. For example, if you have citizens' band transmitters, you can hear these signals if the transmitter is close enough to the signal tracer.

Sometimes you might hear noise from fluorescent lights, auto ignition systems, light dimmers, or switches opening and closing.

### Wiring Sequence:

- 89-97-126
- 90-92-100-EARPHONE-PROBES
- 125-99-91-EARPHONE
- 98-PROBES

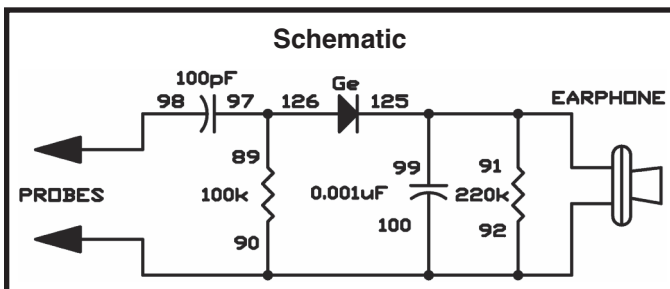

## EXPERIMENT #119: SQUARE WAVE OSCILLATOR

Multivibrator oscillators produce square waves, and you can use square waves as test signals. You should be familiar with multivibrator circuits from previous experiments. The name square wave comes from the pattern produced by the signal on an oscilloscope (shown below).

**Notes:**

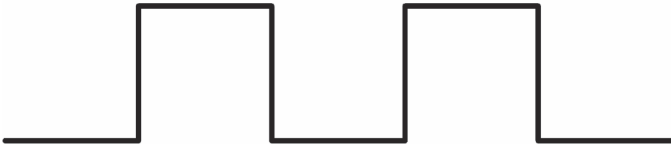

Build this circuit and you will hear the sound produced by a square wave signal. You can differ the pitch and the frequency of the signal by modifying the control. This varies the current supplied to the PNP transistor bases.

### Wiring Sequence:

- 77-75-48-27-124
- 28-81-83
- 40-107-84
- 41-106-76
- 119-42-45-80-EARPHONE
- 43-105-82
- 78-87-108-44
- 46-88
- 47-79-89
- 90-EARPHONE
- 121-122

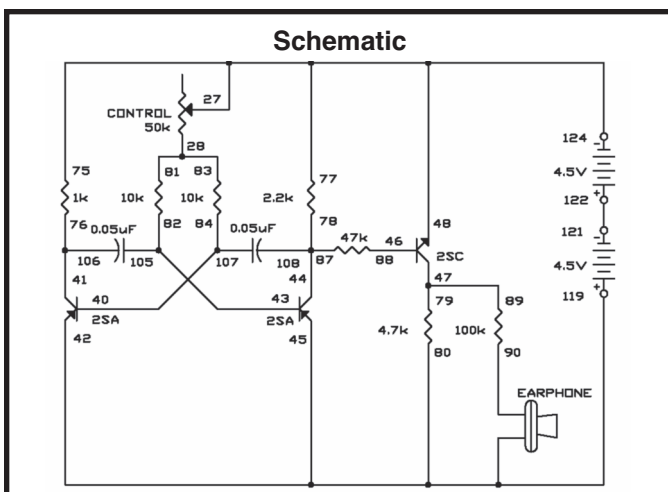

## EXPERIMENT #120: SAWTOOTH OSCILLATOR

When you connect the signal from this oscillator to an oscilloscope, it creates a pattern that looks like the teeth of a saw (as shown below).

Notes:

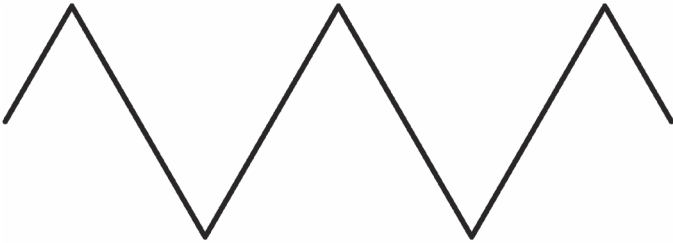

The shape of this wave results from the slow charging of the  $0.1\mu\text{F}$  capacitor through the control and the  $100\text{k}\Omega$  resistor, and the capacitor's discharge through the PNP and NPN transistors.

The voltage divider - the  $470\Omega$  and  $100\Omega$  resistors - provides about 1.6 volts to the transistors. Current flowing from the 9V supply into the  $0.1\mu\text{F}$  capacitor (through the control and the  $100\text{k}\Omega$  resistor) slowly charges up the capacitor. When the capacitor's charge exceeds the voltage of the voltage divider (1.6V), the transistors turn on and provide a path for the  $0.1\mu\text{F}$  capacitor to discharge quickly. Now, the transistors turn off again, and the capacitor begins to slowly charge to repeat the cycle.

You can modify the oscillator frequency by changing the values of the components in the timer circuit - the control, the  $100\text{k}\Omega$  resistor and the  $0.1\mu\text{F}$  capacitor. Try a  $47\text{k}\Omega$  resistor or a  $220\text{k}\Omega$  resistor in place of the  $100\text{k}\Omega$  resistor, and try several different capacitors. If you connect one of the electrolytic capacitors, be sure that you use the proper polarity (+ and -).

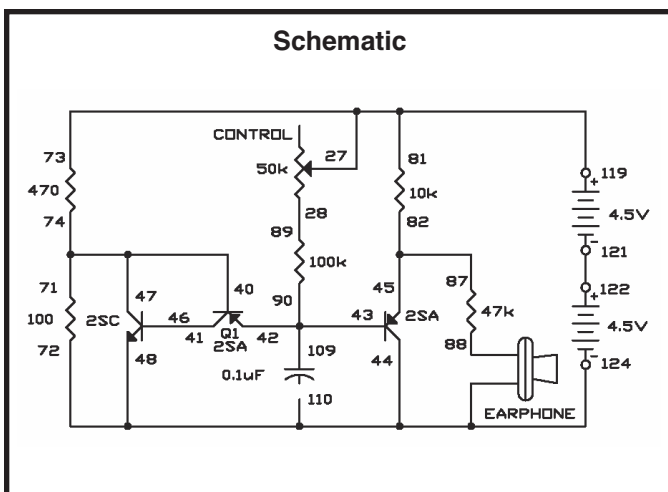

### Wiring Sequence:

- 73-81-27-119
- 28-89
- 71-74-47-40
- 41-46
- 42-43-90-109
- 124-44-48-110-72-EARPHONE
- 45-82-87
- 88-EARPHONE
- 121-122

## EXPERIMENT #121: AUDIO CONTINUITY TESTER

This circuit emits a sound if the material you are checking transmits electricity. This is convenient when you are looking at wires, terminals, or other things and cannot look at a signal lamp or LED. Your ears will detect the results of the test while your eyes are busy.

If the component or circuit you are testing conducts electricity, it will complete the circuit for a pulse-type oscillator. You can use this to test most of the components in this kit. For diodes and transistors, remember that electricity only flows through them in one direction (unless they are damaged).

In the schematic, you will see that the output from the transformer goes through the  $0.02\mu\text{F}$  capacitor and then to the base of the transistor. The TEST terminal is connected to the emitter of the transistor. The transistor starts to oscillate when something that allows electricity to flow is connected to the terminal.

You can safely check almost any component with this continuity checker because it uses a very low current of about 15mA or less. You might want to try measuring the continuity of pencil lines on paper, water, metallic surfaces, and many other things.

### Notes:

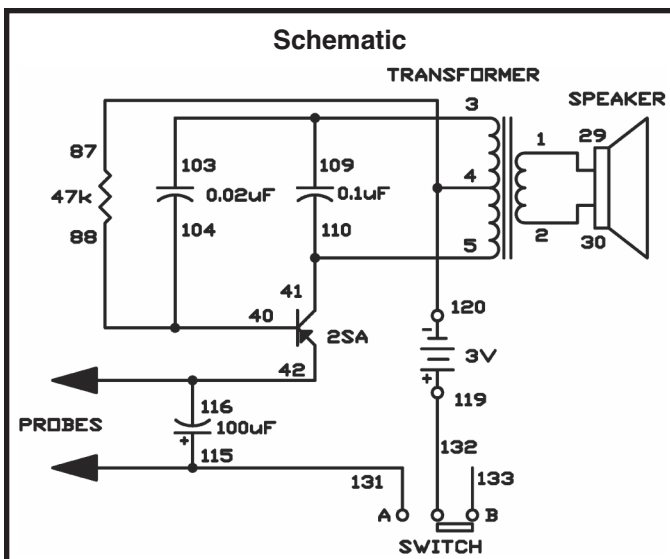

### Wiring Sequence:

- 1-29
- 2-30
- 3-103-109
- 4-87-120
- 5-110-41
- 88-104-40
- 42-116-PROBES
- 115-131-PROBES
- 119-132

## EXPERIMENT #122: AUDIO RAIN DETECTOR

This circuit works as a rain detector. This circuit stays off and draws no current if the resistance between the long wires is more than about  $250k\Omega$ , whether the key is open or closed. The speaker produces a tone when the key is closed and water (or anything else that has a resistance of less than about  $250k\Omega$ ) is connected to both of the test wires.

Connect the wires to other wires or metallic plates laid out on an insulated surface. The alarm turns on when water completes the circuit by spanning the two wires or plates.

This oscillator is the basic pulse-type that we've used several times in this experiment kit. The  $22k\Omega$  resistor protects the circuit against excess base current, in case the wires are shorted together. The  $100k\Omega$  resistor keeps any transistor leakage current from turning on the oscillator.

### Notes:

#### Wiring Sequence:

- 1-29
- 2-30
- 3-104-110
- 124-4-WIRE
- 5-41-109
- 86-89-103-40
- 42-90-138
- 85-WIRE
- 119-137
- 121-122

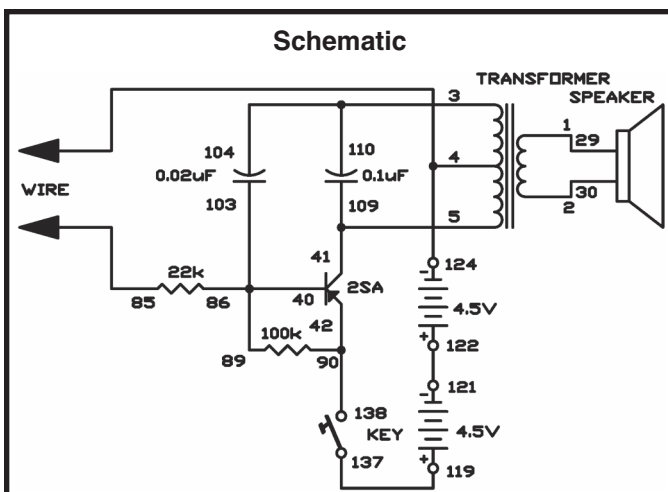



## EXPERIMENT #123: AUDIO METAL DETECTOR

This experiment demonstrates how a metal detector works. When the coil gets close to something that is made of metal, the oscillator changes in frequency. This type of metal detector has been used to locate lost treasures, buried pipes, hidden land mines, and so on. These have been used to save many lives by locating mines and booby traps set out by the enemy during wartime.

This circuit is a low distortion oscillator that draws only one milliamp from the 9V supply. Using low power allows the nearby metal to have maximum effect on oscillation frequency.

You need a small transistor radio to use as the detector; tune it to a weak AM broadcast station. Adjust the tuning capacitor until you hear a low-frequency beat note; this beat note is the difference between the signal of a broadcast station and this oscillator. Do not bring the radio any closer than necessary. The best position is where the levels of the two signals are about equal, because this gives maximum sensitivity.

Try using keys, plastic objects, coins, and so on, as sample objects. Of course, a real metal detector does not have a small ferrite coil like this. It usually uses a Faraday electrostatic shield, which is an air-core coil shielded with an aluminum electrostatic shield.

Try reversing the wire connections on terminals 9 and 10 if the oscillator does not oscillate no matter what you do. If this fixes the problem, reverse the wire connections underneath the board so you can use the proper terminals for this and other similar experiments.

### Notes:

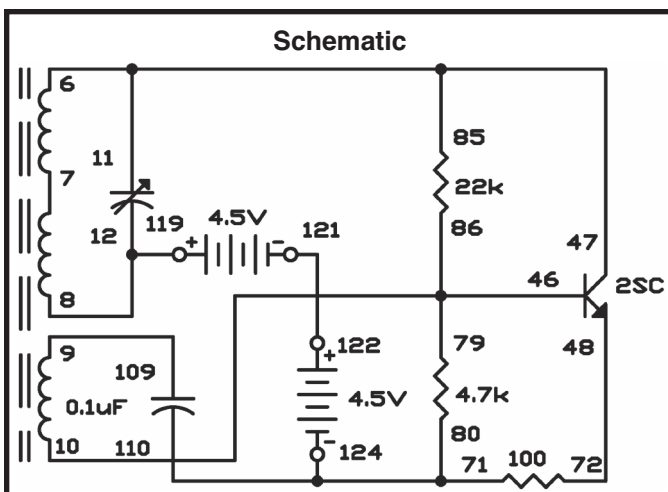

### Wiring Sequence:

- 6-11-85-47
- 8-12-119
- 9-109
- 10-79-86-46
- 48-72
- 71-80-110-124
- 121-122

## EXPERIMENT #124: WATER LEVEL BUZZER

You can use the operational amplifier as a comparator for detecting changes in voltage. In this experiment, you are going to use this comparator function to make a water buzzer that sounds when the wire ends come into contact with water.

Slide the switch to position B, build the circuit, and then slide the switch to position A to turn on the circuit. You should not hear any sound from the speaker. Now connect the two output terminals with a wire, and you hear a sound from the speaker.

Touch the two output terminals with your fingers. If the speaker makes a sound again, the electricity is flowing through your body because the wire lead is in contact with sweat.

This experiment uses two operational amplifiers. IC 1 works as a comparator. The IC's negative (-) input terminal has a reference voltage of about 1.6V. When a voltage exceeding 1.6V is applied to the positive (+) input terminal, the output of the comparator allows IC 2 to work as an astable multivibrator.

### Notes:

#### Wiring Sequence:

- 1-29
- 2-30
- 3-114
- 5-83-80-94-70-110-121
- 13-86-63-131
- 14-93-69
- 65-89-109
- 66-82-84-91
- 64-90-92-113
- 67-81
- 68-79-85
- 119-124
- 122-132

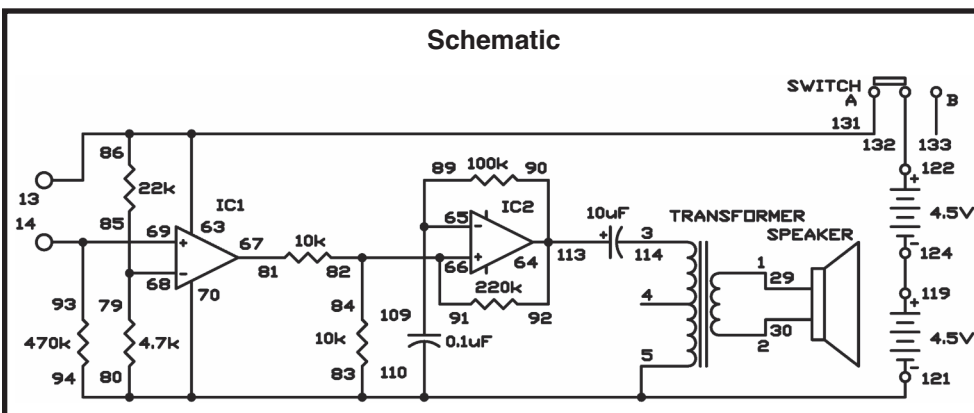

## EXPERIMENT #125: PULSE TONE GENERATOR

This experiment is a pulse-tone oscillator with an adjustable frequency that can obtain a wide range of notes. You can play tunes on it that sound like an electronic organ, but it takes some practice.

To play a tune, modify the control to the proper note and press the key. Readjust the control for the next note and press the key again.

When you close the key the first time, the base current flows around the loop formed by the battery, the 10kΩ resistor, the 50kΩ resistor, the transistor base and emitter, and the key.

The base current causes the collector current to flow around the loop formed by the 3V supply, the lower half of the transformer winding, the transistor collector and emitter, and the key.

The current through the transformer causes a current to flow around the loop formed by the top transformer winding, the 0.05μF capacitor, the transistor base and emitter, the key, the battery and back to the transformer's center terminal (terminal 4). This current quickly (in less than 0.0001 seconds) charges the 0.05μF to about 4V or so with a polarity negative on the transformer side and positive on the transistor base lead side. The speaker is only activated while the current flows in the transformer.

When the induced voltage from the top half of the transformer winding stops, the charging of the 0.05μF capacitor stops, then the capacitor begins to charge again. As soon as the discharge begins, the capacitor voltage becomes higher than the battery voltage. The reverse polarity voltage is applied to the base and the transistor turns off. Now, all transistor junctions act as open circuits. The capacitor discharges around the loop formed by the top transformer winding, the 10kΩ resistor, and the 50kΩ resistor. When you reduce the control setting, the discharge is faster, so the process is repeated at a faster rate causing a higher frequency. The cycle repeats when the 0.05μF capacitor discharges to slightly below the 3V of the battery.

### Notes:

### Wiring Sequence:

- 1-29
- 2-30
- 3-108-110
- 4-82-120
- 27-40-107
- 28-81
- 5-41-109
- 42-137
- 119-138

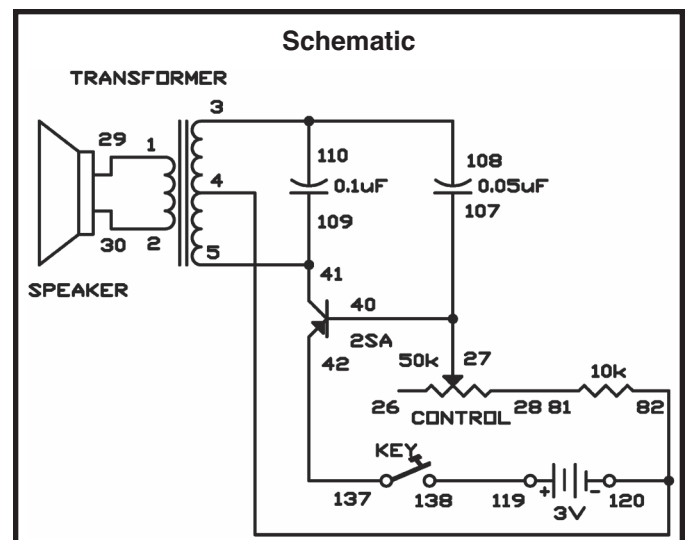

## EXPERIMENT #126: RESISTANCE TESTER

If you use a meter you can find the exact value of a resistance; but when you only want to know approximate resistance values, you can use this resistance tester.

### Notes:

This circuit converts resistance to electric current and compares it with the comparator's reference current to tell you the approximate range of resistance. The comparator has a reference voltage of about 0.82V.

Build the circuit and set the switch to position A. Connect the material to be tested between terminals 13 and 14. The LED lights if the resistance is less than 100k $\Omega$ , otherwise it is off. If the LED lights, connect terminals 93 and 86. If the LED turns off now the resistance is between 10 $\Omega$  and 100k $\Omega$ . If it stays on, remove the wire from terminal 86 and connect it to terminal 84. If the LED turns off now, the resistance is in the range of 1 to 10k $\Omega$ . If the LED still doesn't turn off, remove the wire from terminal 84 and connect it to terminal 76. If the LED turns off now, it means that the resistance is in the range of 100 $\Omega$  to 1k $\Omega$ ; if it stays on, the resistance is less than 100 $\Omega$ .

### Wiring Sequence:

- 13-93-69-WIRE
- 14-79-70-121
- 75-83-94-90-88-31-63-131
- 33-67
- 68-80-87
- 85-89
- 119-124
- 122-132

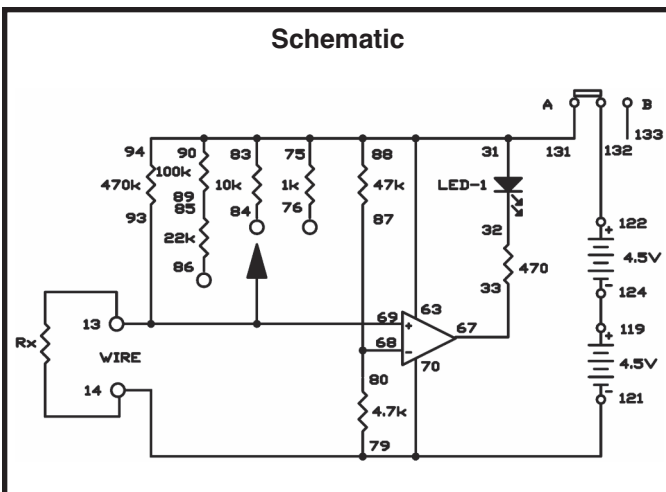

# EXPERIMENT #127: TRANSISTOR TESTER

Transistors are very important, and you may need to test them to be sure they are working. You can't tell if one is working just by looking at it, but this circuit lets you test them. This circuit also checks whether a transistor is a PNP or an NPN.

### Notes:

You'll notice that this project has three long wires - one for the emitter, one for the collector and one for the base. The schematic shows the terminals marked for checking PNP transistors.

To use this experiment, connect the long wires to the base, collector, and emitter of the transistor you want to test. Turn the control fully counter-clockwise. Then, press the key and turn the control clockwise. The transistor is a working PNP transistor if you hear a sound from the speaker. If you hear no sound at all, change connections 4-124 and 119-138 to 4-119 and 124-138, and repeat the test. If you get a sound from the speaker this time, the transistor is a working NPN type. If you get no sound from the speaker using either set of connections, the transistor is defective.

You'll find this a handy circuit for testing unmarked transistors as you start to accumulate parts for other electronic circuits.

### Wiring Sequence:

- 1-29
- 2-30
- 3-105-COLLECTOR
- 4-124
- 5-94-106-110
- 26-72-137
- 27-71
- 28-EMITTER
- 93-109-BASE
- 119-138
- 121-122

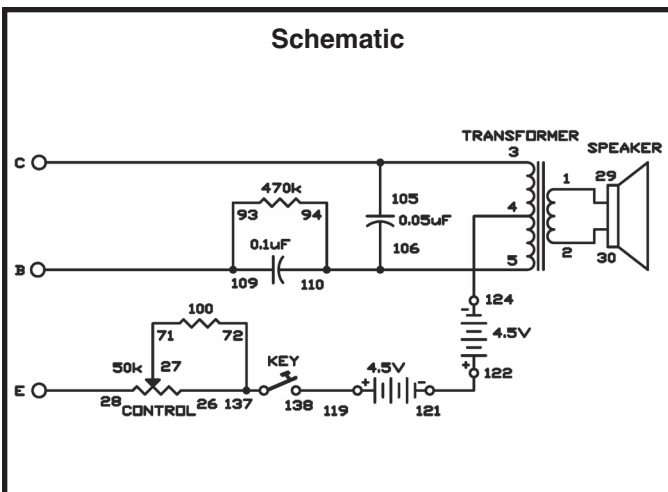

# EXPERIMENT #128: SINE WAVE OSCILLATOR

This oscillator circuit produces a sine wave signal. A sine wave (or sinusoid) is a wave of pure single-frequency tone. As an example, a 400Hz sine wave is a wave that oscillates 400 cycles in one second and contains no other frequency contents. Non-sine waves (such as square wave or triangular wave signals) have harmonics - waves with frequencies that are multiples of the single-frequency fundamental wave. A non-sine 400Hz wave can include the 400Hz wave (its fundamental wave) along with an 800Hz wave (its 2nd harmonic wave) and a 1200Hz wave (its third harmonic wave). A square wave signal contains many harmonics.

Experienced technicians can test a circuit by putting a sine wave into it and listening to its output - and you can too. If you put in a sine wave, and something else comes out, the undesired harmonic frequencies must have been generated somewhere in the circuit.

The key parts of this circuit that produce a 400Hz sine are:

- A 0.1 $\mu$ F capacitor connected across terminals 3 and 5 of the transformer. This forms a tank circuit that resonates at about 600Hz.
- A 470k $\Omega$  resistor to turn on the base of the transistor only a little.
- An adjustable feedback circuit that includes the control and the 0.05 $\mu$ F capacitor.
- A 100 $\Omega$  resistor connected to the emitter. This helps to stabilize the circuit and keep the sound from being distorted.

Connect the earphone to terminals 1 and 2 of the transformer. Start with the control on maximum (10 on the dial) and slowly decrease the control setting while listening to the tone quality of the output. Before the oscillations stop, you will reach a point where you hear only one tone. This last clear-sounding tone is the sine wave. Repeat these control adjustments until you have no trouble distinguishing between a sine wave and a distorted wave.

## Notes:

## Wiring Sequence:

- 1-EARPHONE
- 2-EARPHONE
- 3-28-109
- 4-94-106-124
- 5-41-110
- 26-40-93
- 27-105
- 42-71
- 72-119
- 121-122

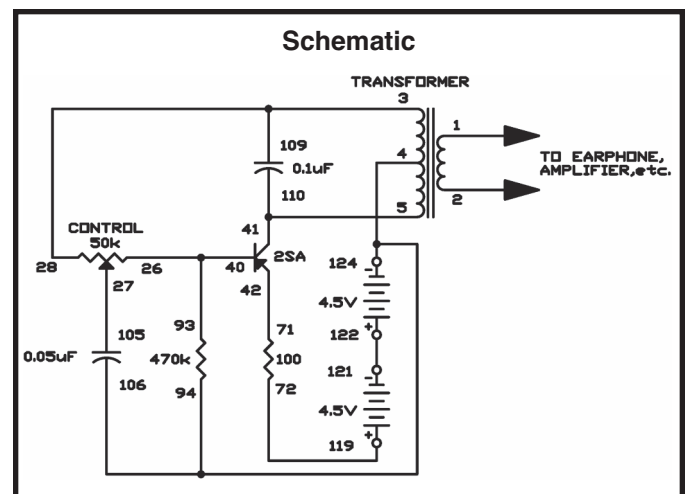

## EXPERIMENT #129: SINE WAVE OSCILLATOR WITH LOW DISTORTION

In this experiment, you build and study a low-distortion sine wave oscillator. Build this experiment after you have built and studied the previous experiment because this one has no transformer; transformers are likely to cause distortion because of their non-linear characteristics.

As in the previous experiment, you should listen to the tone of this oscillator and modify the control for the clearest-sounding single tone (the one with the least distortion). Again, start with the control near maximum. The operating frequency is about 300Hz at the minimum distortion setting of the control.

We call this circuit an RC phase shift oscillator, and it is considered a basic sine wave oscillator. The positive feedback of the signal causes oscillations to occur. The resistors (R) and capacitors (C) make up the path for the signal to the transistor base. Every time the signals pass the RC circuits, a slight time lag occurs. In other words, the rise and fall of the wave (the phase) shifts slightly. That's why we call it phase shift. After the signal has traveled through the circuit, the phase shifts 180 degrees. When the collector voltage rises, this rise is fed back to the collector with the phase shifted. When the base voltage rises, the collector voltage falls. This repeating cycle causes the transistor to oscillate.

The frequency changes when you change the control setting, because the degrees of phase shift changes. The tonal quality also changes. Set the control to the point where you can hear the purest tone; at this point a clear sine wave is generated.

### Notes:

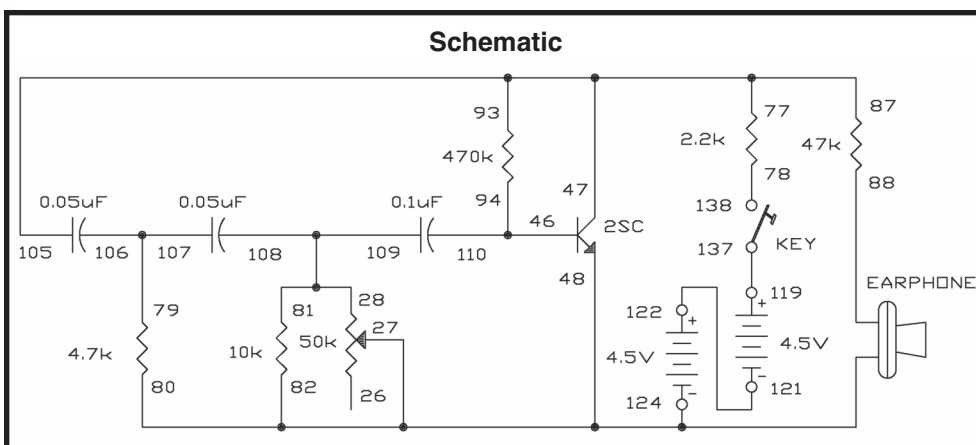

### Wiring Sequence:

- 124-27-48-82-80-EARPHONE
- 47-105-93-77-87
- 88-EARPHONE
- 81-109-108-28
- 94-110-46
- 78-138
- 79-106-107
- 119-137
- 121-122

## EXPERIMENT #130 TWIN-T OSCILLATOR

The twin-T type audio oscillator is very popular for use with electronic organs and electronic test equipment because it is very stable.

The resistors and capacitors in the twin-T network determine the frequency of oscillation. The letter T is used because the resistors and capacitors are arranged in the shape of the letter T in the schematic diagram. There are two T networks in parallel across from each other; hence the term twin is used. The capacitors in series shift the phase of the wave; the resistors in series supply voltage to the transistor's base as well as shifting the phase of the wave.

Carefully adjust the circuit to obtain pure sine wave output as in the previous two projects. Modify the control very slowly over its entire range until you hear a tone in the earphone that is very low and resembles the lowest note of a large pipe organ. This control setting should be between 7 and 10 on your dial.

Once the oscillation has started, adjust the control carefully for the setting that gives the purest sounding low note near the high end of the dial.

You can experiment with this circuit in many ways. We suggest you try different values for the  $10k\Omega$  and  $470\Omega$  resistors, and try using higher and lower battery voltages. Also, if you have a VOM, try measuring circuit voltages.

### Notes:

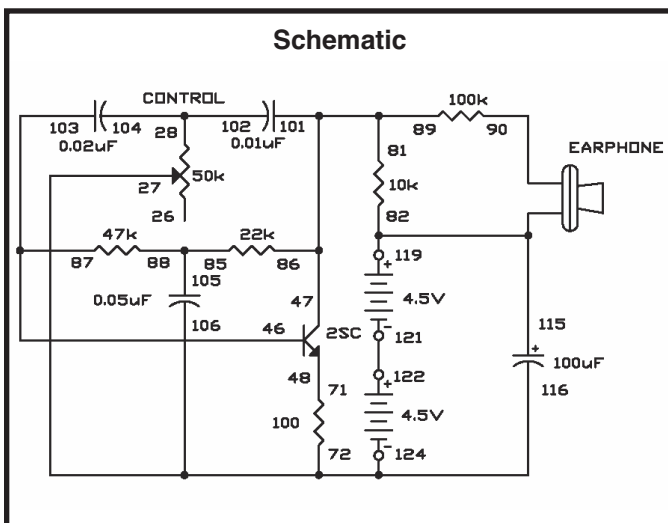

### Wiring Sequence:

- 72-106-116-27-124
- 28-104-102
- 46-103-87
- 47-101-86-81-89
- 90-EARPHONE
- 48-71
- 119-115-82-EARPHONE
- 85-88-105
- 121-122



---

## INDEX

We've added this listing to aid you in finding experiments and circuits that you might be especially interested in. Many of the experiments are listed two, three, or four times - since they can be used in many ways. You'll find some listed as entertainment-type circuits, even though they were not organized that way in the sequence of projects. However, you may find some of these same circuits to be good for other uses too.

Do you want to learn more about a specific type of

circuit? Use this Index to look up all the other uses and applications of any specific circuit - then turn to those and read what we've told you in each one. You'll find by jumping back and forth and around, you often will pick up a lot more circuit details than just by going from one project to the next in sequence.

Use this Index and your own creative ability and we know you will have a lot of extra fun with your Lab Kit.

---

### BASIC ELECTRONIC CIRCUITS AND COMPONENTS

<b>Capacitors:</b>	6, 11, 12, 16, 17, 19, 21, 27, 50, 51, 64, 69, 119, 130
<b>Diodes:</b>	29, 31, 34, 79, 91, 101, 102, 105, 121
<b>Integrated:</b>	34, 70
<b>Multivibrators:</b>	48, 50, 56, 90, 91
<b>Resistance:</b>	2, 10, 12, 18, 21, 25, 60, 74, 77, 78, 94, 102, 114, 120, 123, 126
<b>Set / reset:</b>	58, 59
<b>Timing:</b>	4
<b>Transformers:</b>	129

### ENTERTAINMENT CIRCUITS

<b>Alarm:</b>	58, 63, 66, 92, 93, 105, 107, 116, 120, 123
<b>Audio Oscillators:</b>	51
<b>Buzzing:</b>	56, 57, 92, 107
<b>Code Transmitter:</b>	110
<b>Electronic Cat:</b>	7
<b>Grandfather Clock:</b>	4
<b>Machine Gun:</b>	11
<b>Metal Detector:</b>	123
<b>Metronome:</b>	3, 91
<b>Motorcycle:</b>	12
<b>Musical:</b>	3, 5, 102

<b>Persistence of Vision:</b>	13
<b>Radio:</b>	8, 10, 11, 38, 109, 110, 111, 112, 113, 114, 117, 118, 123, 124
<b>Rain Detector:</b>	120
<b>RF Signal Tracer:</b>	118
<b>Shot in the Dark:</b>	53
<b>Siren:</b>	2, 14, 15, 87, 88, 89, 90, 93
<b>Sound:</b>	1, 2, 3, 4, 5, 6, 8, 10, 11, 12, 14, 15, 19, 22, 49, 52, 54, 55, 56, 57, 58, 59, 63, 64, 66, 72, 87, 88, 89, 90, 93, 102, 103, 105, 108
<b>Strobe:</b>	9
<b>Timer:</b>	54, 55, 78, 99, 107, 108, 119

### INTEGRATED CIRCUIT PROJECTS

<b>Amplifier:</b>	22, 70, 71, 72, 73, 74, 75, 76, 77, 78, 79, 80, 81, 82, 85, 86, 91, 92, 94, 95, 96, 97, 100, 104, 106, 122
<b>Amplifier Uses:</b>	22, 72
<b>IC Radio:</b>	109

### LED DISPLAY

<b>LED Display:</b>	13, 16, 18, 20, 23, 24, 25, 26, 29, 30, 31, 32, 62, 83, 84, 98, 106, 116
<b>Logic:</b>	25, 29, 30, 31, 34, 37, 84, 98

## **LOGIC AND COMPUTER CIRCUITS**

<b>AND Gate:</b>	29, 36, 39, 40
<b>Data:</b>	47
<b>DTL:</b>	29, 30, 31, 33, 35
<b>Exclusive OR:</b>	33, 44
<b>Flip-flop:</b>	27, 28, 38, 43, 58, 59
<b>Inverting:</b>	70, 72, 73, 74, 85, 95, 109
<b>Line:</b>	46
<b>NAND Gate:</b>	31, 41
<b>NOR Gate:</b>	42
<b>OR Gate:</b>	37, 42, 44, 45
<b>Power Supply:</b>	29, 72, 73, 74, 75
<b>TTL:</b>	34, 35, 36, 37, 38, 39, 40, 41, 42, 43, 44, 45, 46, 47, 48, 50, 51, 54, 55, 60, 78, 90, 112, 123

## **NATURAL SCIENCE PROJECTS**

<b>Electrical Energy:</b>	52
<b>Fish:</b>	11

## **OSCILLATORS**

<b>Blocking:</b>	21
<b>Oscillators:</b>	8, 51
<b>Sine wave:</b>	128, 129, 130
<b>Square wave:</b>	67, 86, 96, 118

## **SWITCHING AND CONTROL CIRCUITS**

<b>Relay:</b>	26
<b>Transistor:</b>	27, 28, 61, 67, 95, 101, 113, 127

## **TEST EQUIPMENT**

<b>Transistor Checker:</b>	127
<b>Voltmeters:</b>	25, 68
<b>Water Level:</b>	115

## **TRANSMITTERS**

<b>Code:</b>	110, 114
<b>Tone:</b>	2, 5, 14, 19, 51, 60, 64, 65, 66, 94, 110, 111, 114, 128, 125
<b>Voice:</b>	4, 52, 85, 97, 105, 111

---

## PARTS LIST

Bar Antenna with Holder	PCB for LM358
Battery Box Plastic (2)	Resistors
Capacitors	100Ω 5% 1/4W (4)
10pF, ceramic disc type	470Ω 5% 1/4W
100pF, ceramic disc type	1kΩ 5% 1/4W
0.001μF, ceramic disc type	2.2kΩ 5% 1/4W
0.01μF, ceramic disc type	4.7kΩ 5% 1/4W
0.02μF, ceramic disc type	10kΩ 5% 1/4W (2)
0.05μF, ceramic disc type (2)	22kΩ 5% 1/4W
0.1μF, ceramic disc type	47kΩ 5% 1/4W
3.3μF, 25V electrolytic type	100kΩ 5% 1/4W
10μF, 16V electrolytic type	220kΩ 5% 1/4W
100μF, 10V electrolytic type	470kΩ 5% 1/4W
470μF, 10V electrolytic type	Screw 2.4 x 8mm (4)
CdS Cell	Screw 2.5 x 3mm
Digital Display PCB Assembly	Screw 2.8 x 8mm (2)
LED Digital Display LT-312	Slide Switch
PCB for Digital Display	Speaker, 8Ω
Resistor 360Ω (8)	Spring (138)
Diode Germanium 1N34A (2)	Transformer
Diode Silicon 1SS53 / 1N4148	Transistors
Earphone, ceramic type	2SA733 PNP (2)
Frame, Plastic (L)	2SC945 NPN
Frame, Plastic (R)	Variable Capacitor (tuning)
Integrated Circuit 74LS00	Variable Resistor (control)
Integrated Circuit BA728	Washer 10mm (4)
Key Switch	Wires
Knob, Tuning Capacitor, Plastic	White, 75mm (20)
Knob, Control, Metal	Red, 150mm (30)
Light Emitting Diode (3)	Blue, 250mm (20)
Nut 2mm	Yellow, 350mm (5)
Paper Bottom Panel	Black, 380mm (2)
PCB for 74LS00	Green, 3M (2)

---

## DEFINITION OF TERMS

<b>AC</b>	Common abbreviation for alternating current.	<b>Carbon</b>	A chemical element used to make resistors.
<b>Alternating Current</b>	A current that is constantly changing.	<b>Clockwise</b>	In the direction in which the hands of a clock rotate.
<b>AM</b>	Amplitude modulation. The amplitude of the radio signal is varied depending on the information being sent.	<b>Coil</b>	When something is wound in a spiral. In electronics this describes inductors, which are coiled wires.
<b>Amp</b>	Shortened name for ampere.	<b>Collector</b>	The controlled input of an NPN bipolar junction transistor.
<b>Ampere (A)</b>	The unit of measure for electric current. Commonly shortened to amp.	<b>Color Code</b>	A method for marking resistors using colored bands.
<b>Amplitude</b>	Strength or level of something.	<b>Conductor</b>	A material that has low electrical resistance.
<b>Analogy</b>	A similarity in some ways.	<b>Counter-Clockwise</b>	Opposite the direction in which the hands of a clock rotate.
<b>AND Gate</b>	A type of digital circuit which gives a HIGH output only if all of its inputs are HIGH.	<b>Current</b>	A measure of how fast electrons are flowing in a wire or how fast water is flowing in a pipe.
<b>Antenna</b>	Inductors used for sending or receiving radio signals.	<b>Darlington</b>	A transistor configuration which has high current gain and input resistance.
<b>Astable Multivibrator</b>	A type of transistor configuration in which only one transistor is on at a time.	<b>DC</b>	Common abbreviation for direct current.
<b>Atom</b>	The smallest particle of a chemical element, made up of electrons, protons, etc.	<b>Decode</b>	To recover a message.
<b>Audio</b>	Electrical energy representing voice or music.	<b>Detector</b>	A device or circuit which finds something.
<b>Base</b>	The controlling input of an NPN bipolar junction transistor.	<b>Diaphragm</b>	A flexible wall.
<b>Battery</b>	A device which uses a chemical reaction to create an electric charge across a material.	<b>Differential Pair</b>	A type of transistor configuration.
<b>Bias</b>	The state of the DC voltages across a diode or transistor.	<b>Digital Circuit</b>	A wide range of circuits in which all inputs and outputs have only two states, such as high/low.
<b>Bipolar Junction Transistor (BJT)</b>	A widely used type of transistor.	<b>Diode</b>	An electronic device that allows current to flow in only one direction.
<b>Bistable Switch</b>	A type of transistor configuration, also known as the flip-flop.	<b>Direct Current</b>	A current that is constant and not changing.
<b>Capacitance</b>	The ability to store electric charge.	<b>Disc Capacitor</b>	A type of capacitor that has low capacitance and is used mostly in high frequency circuits.
<b>Capacitor</b>	An electrical component that can store electrical pressure (voltage) for periods of time.		

<b>Electric Field</b>	The region of electric attraction or repulsion around a constant voltage. This is usually associated with the dielectric in a capacitor.	<b>Inductance</b>	The ability of a wire to create an induced voltage when the current varies, due to magnetic effects.
<b>Electricity</b>	A flow of electrons between atoms due to an electrical charge across the material.	<b>Inductor</b>	A component that opposes changes in electrical current.
<b>Electrolytic Capacitor</b>	A type of capacitor that has high capacitance and is used mostly in low frequency circuits. It has polarity markings.	<b>Integrated Circuit</b>	A type of circuit in which transistors, diodes, resistors, and capacitors are all constructed on a semiconductor base.
<b>Electron</b>	A sub-atomic particle that has an electrical charge.	<b>Kilo- (K)</b>	A prefix used in the metric system. It means a thousand of something.
<b>Electronics</b>	The science of electricity and its applications.	<b>Light Emitting Diode (LED)</b>	A diode made from gallium arsenide that has a turn-on energy so high that light is generated when current flows through it.
<b>Emitter</b>	The output of an NPN bipolar junction transistor.	<b>Magnetic Field</b>	The region of magnetic attraction or repulsion around a magnet or an AC current. This is usually associated with an inductor or transformer.
<b>Encode</b>	To put a message into a format which is easier to transmit.	<b>Magnetism</b>	A force of attraction between certain metals. Electric currents also have magnetic properties.
<b>Farad, (F)</b>	The unit of measure for capacitance.	<b>Meg- (M)</b>	A prefix used in the metric system. It means a million of something.
<b>Feedback</b>	To adjust the input to something based on what its output is doing.	<b>Micro- (<math>\mu</math>)</b>	A prefix used in the metric system. It means a millionth (0.000,001) of something.
<b>Flip-Flop</b>	A type of transistor configuration is which the output changes every time it receives an input pulse.	<b>Microphone</b>	A device which converts sound waves into electrical energy.
<b>FM</b>	Frequency modulation. The frequency of the radio signal is varied depending on the information being sent.	<b>Milli- (m)</b>	A prefix used in the metric system. It means a thousandth (0.001) of something.
<b>Forward-Biased</b>	The state of a diode when current is flowing through it.	<b>Modulation</b>	Methods used for encoding radio signals with information.
<b>Frequency</b>	The rate at which something repeats.	<b>Morse Code</b>	A code used to send messages with long or short transmit bursts.
<b>Generator</b>	A device which uses steam or water pressure to move a magnet near a wire, creating an electric current in the wire.	<b>NAND Gate</b>	A type of digital circuit which gives a HIGH output if some of its inputs are LOW.
<b>Germanium</b>	A chemical element that is used as a semiconductor.	<b>NPN</b>	Negative-Positive-Negative, a type of transistor construction.
<b>Ground</b>	A common term for the 0V or “-” side of a battery or generator.		
<b>Henry (H)</b>	The unit of measure for Inductance.		

<b>Ohm's Law</b>	The relationship between voltage, current, and resistance.	<b>Semiconductor</b>	A material that has more resistance than conductors but less than insulators. It is used to construct diodes, transistors, and integrated circuits.
<b>Ohm, (<math>\Omega</math>)</b>	The unit of measure for resistance.	<b>Series</b>	When electrical components are connected one after the other.
<b>Oscillator</b>	A circuit that uses feedback to generate an AC output.	<b>Short Circuit</b>	When wires from different parts of a circuit (or different circuits) connect accidentally.
<b>Parallel</b>	When several electrical components are connected between the same points in the circuit.	<b>Silicon</b>	The chemical element most commonly used as a semiconductor.
<b>Pico- (p)</b>	A prefix used in the metric system. It means a millionth of a millionth (0.000,000,000,001) of something.	<b>Speaker</b>	A device which converts electrical energy into sound.
<b>Pitch</b>	The musical term for frequency.	<b>Switch</b>	A device to connect ("closed" or "on") or disconnect ("open" or "off") wires in an electric circuit.
<b>Printed Circuit Board</b>	A board used for mounting electrical components. Components are connected using metal traces "printed" on the board instead of wires.	<b>Transformer</b>	A device which uses two coils to change the AC voltage and current (increasing one while decreasing the other).
<b>Receiver</b>	The device which is receiving a message (usually with radio).	<b>Transient</b>	Temporary. Used to describe DC changes to circuits.
<b>Resistance</b>	The electrical friction between an electric current and the material it is flowing through; the loss of energy from electrons as they move between atoms of the material.	<b>Transistor</b>	An electronic device that uses a small amount of current to control a large amount of current.
<b>Resistor</b>	Components used to control the flow of electricity in a circuit. They are made of carbon.	<b>Transmitter</b>	The device which is sending a message (usually with radio).
<b>Resistor-Transistor-Logic (RTL)</b>	A type of circuit arrangement used to construct digital gates.	<b>Tuning Capacitor</b>	A capacitor whose value is varied by rotating conductive plates over a dielectric.
<b>Reverse-Biased</b>	When there is a voltage in the direction of high-resistance across a diode.	<b>Variable Resistor</b>	A resistor with an additional arm contact that can move along the resistive material and tap off the desired resistance.
<b>Saturation</b>	The state of a transistor when the circuit resistances, not the transistor itself, are limiting the current.	<b>Voltage</b>	A measure of how strong an electric charge across a material is.
<b>Schematic</b>	A drawing of an electrical circuit that uses symbols for all the components.	<b>Voltage Divider</b>	A resistor configuration to create a lower voltage.
		<b>Volts (V)</b>	The unit of measure for voltage.

## IDENTIFYING RESISTOR VALUES

Use the following information as a guide in properly identifying the value of resistors.

BAND 1 1st Digit	
Color	Digit
Black	0
Brown	1
Red	2
Orange	3
Yellow	4
Green	5
Blue	6
Violet	7
Gray	8
White	9

BAND 2 2nd Digit	
Color	Digit
Black	0
Brown	1
Red	2
Orange	3
Yellow	4
Green	5
Blue	6
Violet	7
Gray	8
White	9

Multiplier	
Color	Multiplier
Black	1
Brown	10
Red	100
Orange	1,000
Yellow	10,000
Green	100,000
Blue	1,000,000
Silver	0.01
Gold	0.1

Resistance Tolerance	
Color	Tolerance
Silver	±10%
Gold	±5%
Brown	±1%
Red	±2%
Orange	±3%
Green	±0.5%
Blue	±0.25%
Violet	±0.1%

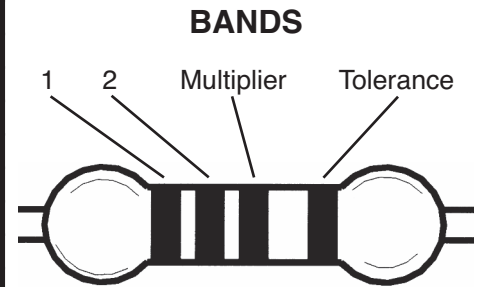

## IDENTIFYING CAPACITOR VALUES

Capacitors will be identified by their capacitance value in pF (picofarads), nF (nanofarads), or  $\mu$ F (microfarads). Most capacitors will have their actual value printed on them. Some capacitors may have their value printed in the following manner. The maximum operating voltage may also be printed on the capacitor.

Electrolytic capacitors have a positive and a negative electrode. The negative lead is indicated on the packaging by a stripe with minus signs and possibly arrowheads.

**Warning:**  
If the electrolytic capacitor is connected with incorrect polarity, it may heat up and either leak, or cause the capacitor to explode.



Multiplier	For the No.	0	1	2	3	4	5	8	9
	Multiply By	1	10	100	1k	10k	100k	.01	0.1

Second Digit → Multiplier

First Digit → Tolerance\*

Maximum Working Voltage

The value is  $10 \times 1,000 = 10,000\text{pF}$  or  $.01\mu\text{F}$  100V

\* The letter M indicates a tolerance of  $\pm 20\%$   
The letter K indicates a tolerance of  $\pm 10\%$   
The letter J indicates a tolerance of  $\pm 5\%$

**Note:** The letter "R" may be used at times to signify a decimal point; as in 3R3 = 3.3

### Note: EP-130

For safety, the electrolytic capacitors used in the EP-130 are

## METRIC UNITS AND CONVERSIONS

Abbreviation	Means	Multiply Unit By	Or
p	pico	.000000000001	$10^{-12}$
n	nano	.000000001	$10^{-9}$
$\mu$	micro	.000001	$10^{-6}$
m	milli	.001	$10^{-3}$
-	unit	1	$10^0$
k	kilo	1,000	$10^3$
M	mega	1,000,000	$10^6$

1. 1,000 pico units	= 1 nano unit
2. 1,000 nano units	= 1 micro unit
3. 1,000 micro units	= 1 milli unit
4. 1,000 milli units	= 1 unit
5. 1,000 units	= 1 kilo unit
6. 1,000 kilo units	= 1 mega unit

**ELENCO®**

150 Carpenter Avenue

Wheeling, IL 60090

(847) 541-3800

Website: [www.elenco.com](http://www.elenco.com)

e-mail: [elenco@elenco.com](mailto:elenco@elenco.com)





Компания «ЭлектроПласт» предлагает заключение долгосрочных отношений при поставках импортных электронных компонентов на взаимовыгодных условиях!

Наши преимущества:

- Оперативные поставки широкого спектра электронных компонентов отечественного и импортного производства напрямую от производителей и с крупнейших мировых складов;
- Поставка более 17-ти миллионов наименований электронных компонентов;
- Поставка сложных, дефицитных, либо снятых с производства позиций;
- Оперативные сроки поставки под заказ (от 5 рабочих дней);
- Экспресс доставка в любую точку России;
- Техническая поддержка проекта, помощь в подборе аналогов, поставка прототипов;
- Система менеджмента качества сертифицирована по Международному стандарту ISO 9001;
- Лицензия ФСБ на осуществление работ с использованием сведений, составляющих государственную тайну;
- Поставка специализированных компонентов (Xilinx, Altera, Analog Devices, Intersil, Interpoint, Microsemi, Aeroflex, Peregrine, Syfer, Eurofarad, Texas Instrument, Miteq, Cobham, E2V, MA-COM, Hittite, Mini-Circuits, General Dynamics и др.);

Помимо этого, одним из направлений компании «ЭлектроПласт» является направление «Источники питания». Мы предлагаем Вам помощь Конструкторского отдела:

- Подбор оптимального решения, техническое обоснование при выборе компонента;
- Подбор аналогов;
- Консультации по применению компонента;
- Поставка образцов и прототипов;
- Техническая поддержка проекта;
- Защита от снятия компонента с производства.



#### Как с нами связаться

**Телефон:** 8 (812) 309 58 32 (многоканальный)

**Факс:** 8 (812) 320-02-42

**Электронная почта:** [org@eplast1.ru](mailto:org@eplast1.ru)

**Адрес:** 198099, г. Санкт-Петербург, ул. Калинина, дом 2, корпус 4, литера А.