



# Thermocouple Reference Design

---

**Note the following details of the code protection feature on Microchip devices:**

- Microchip products meet the specification contained in their particular Microchip Data Sheet.
- Microchip believes that its family of products is one of the most secure families of its kind on the market today, when used in the intended manner and under normal conditions.
- There are dishonest and possibly illegal methods used to breach the code protection feature. All of these methods, to our knowledge, require using the Microchip products in a manner outside the operating specifications contained in Microchip's Data Sheets. Most likely, the person doing so is engaged in theft of intellectual property.
- Microchip is willing to work with the customer who is concerned about the integrity of their code.
- Neither Microchip nor any other semiconductor manufacturer can guarantee the security of their code. Code protection does not mean that we are guaranteeing the product as "unbreakable."

Code protection is constantly evolving. We at Microchip are committed to continuously improving the code protection features of our products. Attempts to break Microchip's code protection feature may be a violation of the Digital Millennium Copyright Act. If such acts allow unauthorized access to your software or other copyrighted work, you may have a right to sue for relief under that Act.

---

Information contained in this publication regarding device applications and the like is provided only for your convenience and may be superseded by updates. It is your responsibility to ensure that your application meets with your specifications. MICROCHIP MAKES NO REPRESENTATIONS OR WARRANTIES OF ANY KIND WHETHER EXPRESS OR IMPLIED, WRITTEN OR ORAL, STATUTORY OR OTHERWISE, RELATED TO THE INFORMATION, INCLUDING BUT NOT LIMITED TO ITS CONDITION, QUALITY, PERFORMANCE, MERCHANTABILITY OR FITNESS FOR PURPOSE. Microchip disclaims all liability arising from this information and its use. Use of Microchip devices in life support and/or safety applications is entirely at the buyer's risk, and the buyer agrees to defend, indemnify and hold harmless Microchip from any and all damages, claims, suits, or expenses resulting from such use. No licenses are conveyed, implicitly or otherwise, under any Microchip intellectual property rights.

**Trademarks**

The Microchip name and logo, the Microchip logo, dsPIC, KEELOQ, KEELOQ logo, MPLAB, PIC, PICmicro, PICSTART, rfPIC and UNI/O are registered trademarks of Microchip Technology Incorporated in the U.S.A. and other countries.

FilterLab, Hampshire, HI-TECH C, Linear Active Thermistor, MXDEV, MXLAB, SEEVAL and The Embedded Control Solutions Company are registered trademarks of Microchip Technology Incorporated in the U.S.A.

Analog-for-the-Digital Age, Application Maestro, CodeGuard, dsPICDEM, dsPICDEM.net, dsPICworks, dsSPEAK, ECAN, ECONOMONITOR, FanSense, HI-TIDE, In-Circuit Serial Programming, ICSP, Mindi, MiWi, MPASM, MPLAB Certified logo, MPLIB, MPLINK, mTouch, Octopus, Omniscient Code Generation, PICC, PICC-18, PICDEM, PICDEM.net, PICKit, PICtail, PIC<sup>32</sup> logo, REAL ICE, rLAB, Select Mode, Total Endurance, TSHARC, UniWinDriver, WiperLock and ZENA are trademarks of Microchip Technology Incorporated in the U.S.A. and other countries.

SQTP is a service mark of Microchip Technology Incorporated in the U.S.A.

All other trademarks mentioned herein are property of their respective companies.

© 2010, Microchip Technology Incorporated, Printed in the U.S.A., All Rights Reserved.

 Printed on recycled paper.

**QUALITY MANAGEMENT SYSTEM**  
**CERTIFIED BY DNV**  
**== ISO/TS 16949:2002 ==**

*Microchip received ISO/TS-16949:2002 certification for its worldwide headquarters, design and wafer fabrication facilities in Chandler and Tempe, Arizona; Gresham, Oregon and design centers in California and India. The Company's quality system processes and procedures are for its PIC<sup>®</sup> MCUs and dsPIC<sup>®</sup> DSCs, KEELOQ<sup>®</sup> code hopping devices, Serial EEPROMs, microperipherals, nonvolatile memory and analog products. In addition, Microchip's quality system for the design and manufacture of development systems is ISO 9001:2000 certified.*

**Table of Contents**

<b>Preface</b> .....	<b>5</b>
Introduction.....	5
Document Layout .....	5
Conventions Used in this Guide .....	6
Recommended Reading.....	7
The Microchip Web Site .....	7
Customer Support .....	7
Document Revision History .....	7
 <b>Chapter 1. Product Overview</b>	
1.1 Introduction .....	9
1.2 What is the Thermocouple Reference Design? .....	9
1.3 What the Thermocouple Reference Design kit includes .....	9
 <b>Chapter 2. Installation and Operation</b>	
2.1 Introduction .....	11
2.2 Features .....	11
2.3 Getting Started .....	12
2.3.1 Hardware Setup .....	12
2.3.2 Software Setup .....	13
2.3.3 Sensor Calibration and Setup .....	15
 <b>Appendix A. Schematic and Layouts</b>	
A.1 Introduction .....	17
A.2 Board - Schematic .....	18
A.3 Board -Top Silk and Pads .....	19
A.4 Board - Internal V <sub>DD</sub> Layer .....	19
A.5 Board - Internal Ground Layer .....	20
A.6 Board - Bottom Silk and Pads .....	20
 <b>Appendix B. Bill of Materials</b>	
<b>Worldwide Sales and Service</b> .....	<b>22</b>

# Thermocouple Reference Design

---

NOTES:

---

---

## Preface

---

---

### NOTICE TO CUSTOMERS

All documentation becomes dated, and this manual is no exception. Microchip tools and documentation are constantly evolving to meet customer needs, so some actual dialogs and/or tool descriptions may differ from those in this document. Please refer to our web site ([www.microchip.com](http://www.microchip.com)) to obtain the latest documentation available.

Documents are identified with a “DS” number. This number is located on the bottom of each page, in front of the page number. The numbering convention for the DS number is “DSXXXXA”, where “XXXX” is the document number and “A” is the revision level of the document.

For the most up-to-date information on development tools, see the MPLAB® IDE on-line help. Select the Help menu, and then Topics to open a list of available on-line help files.

## INTRODUCTION

This chapter contains general information that will be useful to know before using the Thermocouple Reference Design. Items discussed in this chapter include:

- Document Layout
- Conventions Used in this Guide
- Recommended Reading
- The Microchip Web Site
- Customer Support
- Document Revision History

## DOCUMENT LAYOUT

This document describes how to use the Thermocouple Reference Design as a development tool to emulate and debug firmware on a target board. The manual layout is as follows:

- **Chapter 1. “Product Overview”** – Important information about the Thermocouple Reference Design.
- **Chapter 2. “Installation and Operation”** – This chapter includes a detailed description of each function of the demo board and instructions for how to begin using the board.
- **Appendix A. “Schematic and Layouts”** – Shows the schematic and layout diagrams for the Thermocouple Reference Design.
- **Appendix B. “Bill of Materials”** – Lists the parts used to build the Thermocouple Reference Design.

# Thermocouple Reference Design

---

## CONVENTIONS USED IN THIS GUIDE

This manual uses the following documentation conventions:

### DOCUMENTATION CONVENTIONS

Description	Represents	Examples
<b>Arial font:</b>		
Italic characters	Referenced books	<i>MPLAB<sup>®</sup> IDE User's Guide</i>
	Emphasized text	...is the <i>only</i> compiler...
Initial caps	A window	the Output window
	A dialog	the Settings dialog
	A menu selection	select Enable Programmer
Quotes	A field name in a window or dialog	"Save project before build"
Underlined, italic text with right angle bracket	A menu path	<u><i>File&gt;Save</i></u>
Bold characters	A dialog button	Click <b>OK</b>
	A tab	Click the <b>Power</b> tab
N'Rnnnn	A number in verilog format, where N is the total number of digits, R is the radix and n is a digit.	4'b0010, 2'hF1
Text in angle brackets < >	A key on the keyboard	Press <Enter>, <F1>
<b>Courier New font:</b>		
Plain Courier New	Sample source code	#define START
	Filenames	autoexec.bat
	File paths	c:\mcc18\h
	Keywords	_asm, _endasm, static
	Command-line options	-Opa+, -Opa-
	Bit values	0, 1
	Constants	0xFF, 'A'
Italic Courier New	A variable argument	<i>file.o</i> , where <i>file</i> can be any valid filename
Square brackets [ ]	Optional arguments	mcc18 [options] <i>file</i> [options]
Curly brackets and pipe character: {   }	Choice of mutually exclusive arguments; an OR selection	errorlevel {0 1}
Ellipses...	Replaces repeated text	var_name [, var_name...]
	Represents code supplied by user	void main (void) { ... }

## RECOMMENDED READING

This user's guide describes how to use Thermocouple Reference Design. Other useful documents are listed below. The following Microchip documents are available and recommended as supplemental reference resources.

**MCP3421 Data Sheet, “18-Bit Analog-to-Digital Converter with  $\mathcal{I}^2\mathcal{C}$  Interface and On-Board Reference” (DS22003).**

This data sheet provides detailed information regarding the MCP3421 device.

## THE MICROCHIP WEB SITE

Microchip provides online support via our web site at [www.microchip.com](http://www.microchip.com). This web site is used as a means to make files and information easily available to customers. Accessible by using your favorite Internet browser, the web site contains the following information:

- **Product Support** – Data sheets and errata, application notes and sample programs, design resources, user's guides and hardware support documents, latest software releases and archived software
- **General Technical Support** – Frequently Asked Questions (FAQs), technical support requests, online discussion groups, Microchip consultant program member listing
- **Business of Microchip** – Product selector and ordering guides, latest Microchip press releases, listing of seminars and events, listings of Microchip sales offices, distributors and factory representatives

## CUSTOMER SUPPORT

Users of Microchip products can receive assistance through several channels:

- Distributor or Representative
- Local Sales Office
- Field Application Engineer (FAE)
- Technical Support

Customers should contact their distributor, representative or field application engineer (FAE) for support. Local sales offices are also available to help customers. A listing of sales offices and locations is included in the back of this document.

Technical support is available through the web site at: <http://support.microchip.com>

## DOCUMENT REVISION HISTORY

### Revision A (December 2009)

- Initial Release of this Document.

# Thermocouple Reference Design

---

NOTES:



---

---

## Chapter 1. Product Overview

---

---

### 1.1 INTRODUCTION

The following name and assembly number are found on the Thermocouple Reference Design's Printed Circuit Board (PCB):

- 102-00114

### 1.2 WHAT IS THE THERMOCOUPLE REFERENCE DESIGN?

The Thermocouple Reference Design demonstrates how to instrument a Thermocouple and accurately sense temperature over the entire Thermocouple measurement range. This solution uses the MCP3421 18-Bit Analog-to-Digital Converter (ADC) to measure voltage across the Thermocouple. The ADC has an internal 2.048V reference voltage and a Programmable Gain Amplifier with 1, 2, 4, 8V/V. At a Gain of 8V/V the PGA effectively adds 3LSb to the ADC. This increases the ADC resolution to 21-bit or 2  $\mu\text{V}/\text{LSb}$ . Therefore, the Thermocouple EMF voltage is measured with 2  $\mu\text{V}$  resolution. For K-type Thermocouple, measurement system provides a  $\pm 0.05^\circ\text{C}$  resolution. The cold-junction compensation is done using a  $\pm 1^\circ\text{C}$  accurate  $0.0625^\circ\text{C}$  resolution silicon temperature sensor, the MCP9804. This solution provides a reliable and accurate Thermocouple instrumentation without the need for extensive circuit compensation and calibration routines.

The ADC output is read using a PICmicro Microcontroller. This controller is also connected to a PC using USB interface. The Thermal Management software is used to plot the Thermocouple temperature data in stripchart format.

### 1.3 WHAT THE THERMOCOUPLE REFERENCE DESIGN KIT INCLUDES

This Thermocouple Reference Design Kit includes:

- Thermocouple Reference Design, 102-00114
- K-type Thermocouple
- Important Information Sheet

# Thermocouple Reference Design

---

NOTES:

---

---

## Chapter 2. Installation and Operation

---

---

### 2.1 INTRODUCTION

The Thermocouple Reference Design demonstrates Microchip's solution to accurately measure temperature using a Thermocouple and an 18-bit ADC, MCP3421. This solution eliminates the need for the traditional analog instrumentation system calibration or gain and offset trimming techniques. In addition, the Thermocouple linearization techniques can be implemented in firmware or software.

The Thermocouple Reference Design allows user to evaluate Microchip's solution to accurately measure the temperature. When measuring temperature using a Thermocouple cold junction compensation is critical. It provides a reference to the thermocouple measurement. The MCP9804 provides the cold junction compensation at  $\pm 1^{\circ}\text{C}$  accuracy. If the Thermocouple is compensated using the compensation equation provided by National Institute of Standards and Technology (NIST ITS-90), then temperature can be measured with  $\pm 1^{\circ}\text{C}$  accuracy over the entire measurement range.

The MCP3421 and the MCP9804 serial output lines are connected to a PICMicro Microcontroller. This controller communicates with a PC via the USB interface and commands the ADC to convert voltage. The serial data is then displayed on the PC using the Thermal Management software in stripchart format.

### 2.2 FEATURES

The Thermocouple Reference Design has the following features:

- K-type Thermocouple
- Thermocouple connector
- Thermal Management GUI
- MCP9804 Temperature sensor with  $\pm 0.25^{\circ}\text{C}$  (typical) accuracy from  $-40^{\circ}\text{C}$  to  $+125^{\circ}\text{C}$
- 18-Bit ADC MCP3421
- PIC18F2550 PIC<sup>®</sup> Microcontroller
- USB interface to PC

# Thermocouple Reference Design

## 2.3 GETTING STARTED

This section describes how to quickly configure the Thermocouple Reference Design. A simplified block diagram of the configuration is provided in Figure 2-1.

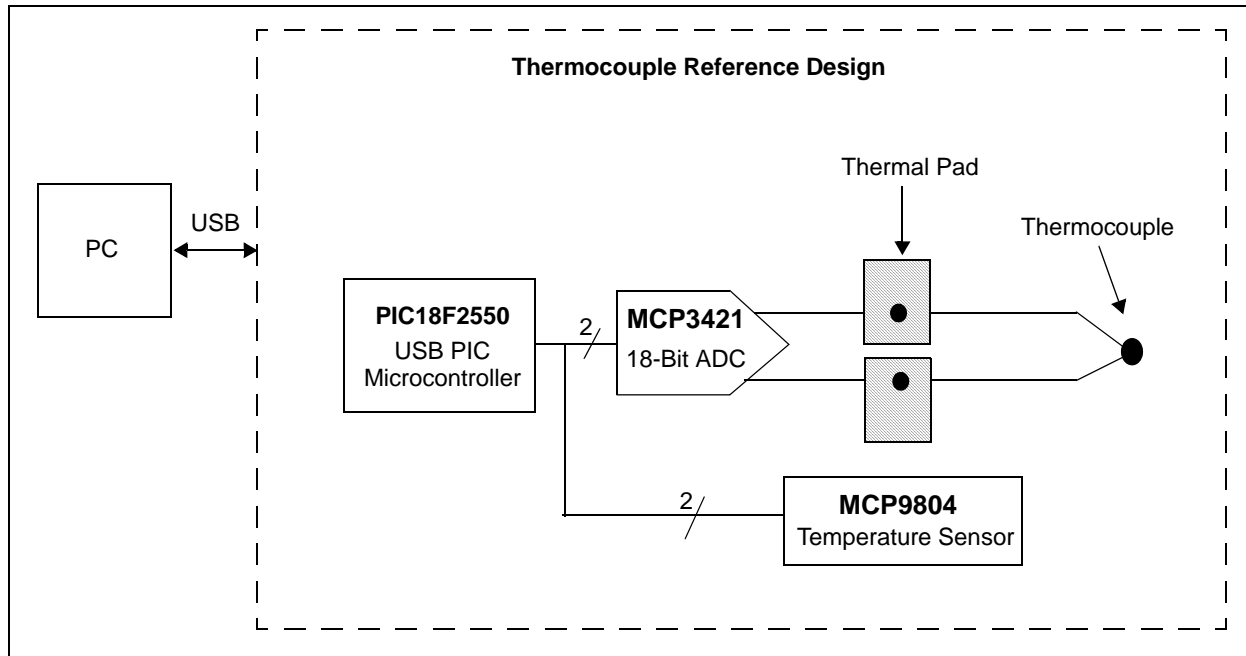

**FIGURE 2-1:** Thermocouple Reference Design Simplified Block Diagram.

### 2.3.1 Hardware Setup

1. Connect the USB cable to PC.
2. Start the Thermal Management software.
3. Click the **Start** icon to start acquisition and measure temperature from the Thermocouple.

## 2.3.2 Software Setup

Once the USB interface is secured, start the Thermal Management Software. When the software starts, if the hardware is successfully detected then the GUI will be displayed.

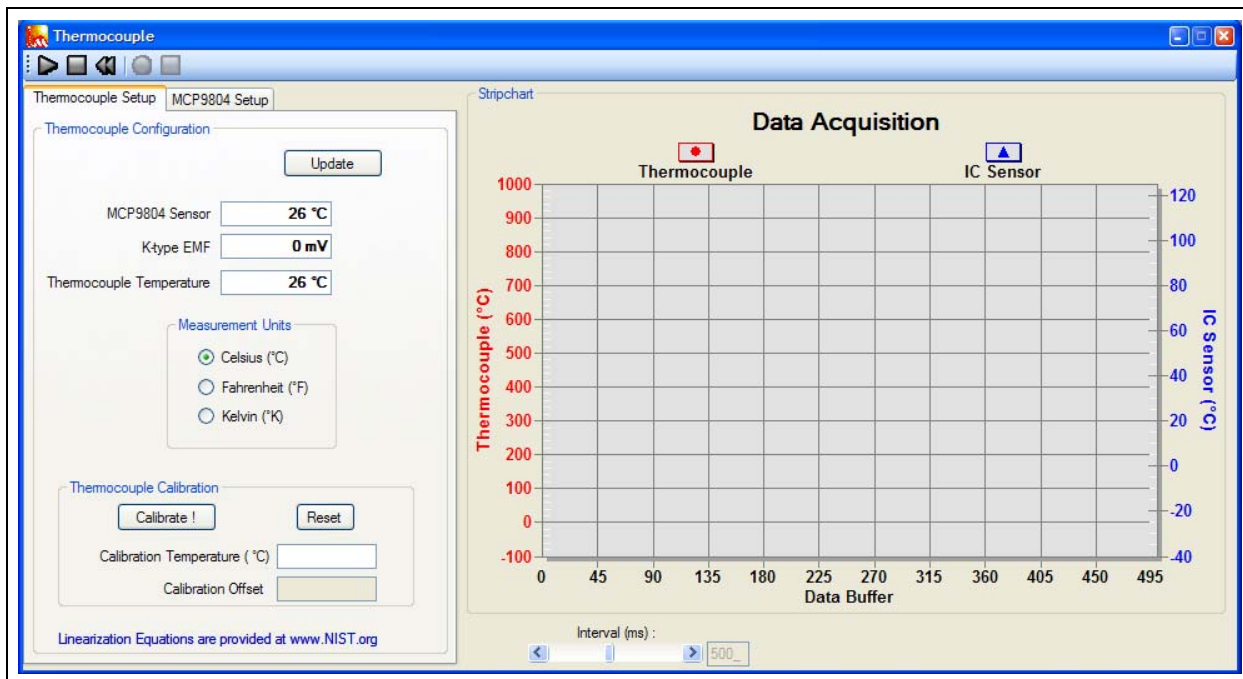

**FIGURE 2-2:** Thermocouple Reference Design GUI.

This configuration window allows the user to set some of parameters, such as measurement unit and calibration temperature.

The **Play**, **Stop** and **Reset** icons can be used to perform continuous data-log. The **Record** icon enables the user to data-log to an external file. The logging interval can be adjusted using the Interval Scroll bar from 100 ms to 30s.

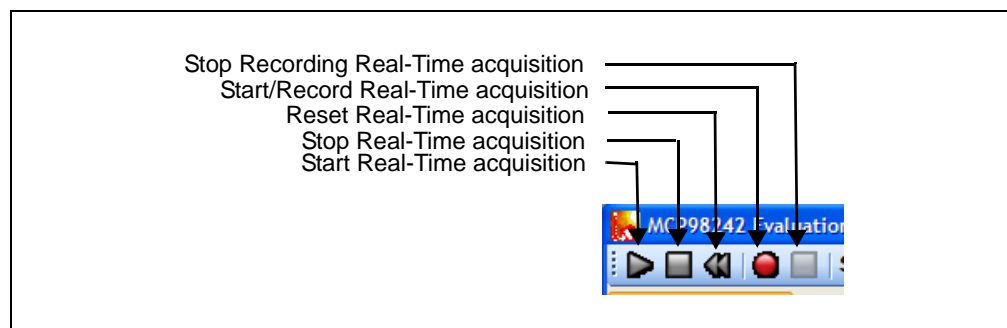
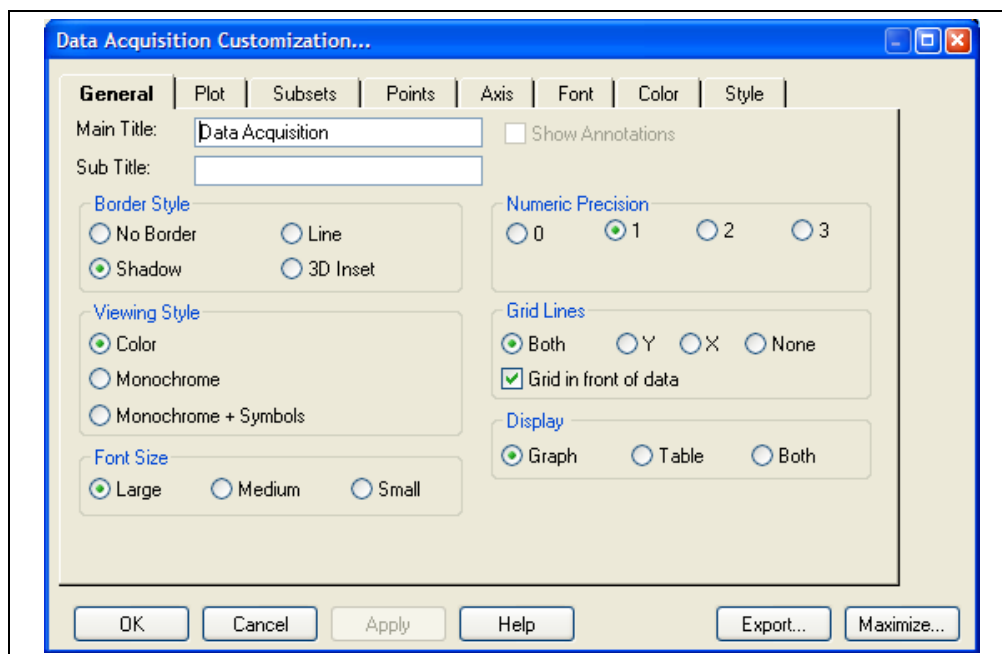

**FIGURE 2-3:** Real-Time Acquisition.

Thermocouple output is using the compensation equation provided by National Institute of Standards and Technology (NIST ITS-90). The linearization is implemented in the PICmicro microcontroller.

# Thermocouple Reference Design

The Data Acquisition charting tool can be customized by double clicking the chart, as shown in Figure 2-4. Additional options are available by right-clicking the chart. The user can also zoom into a specific plot range by clicking and dragging the section. The data in the chart can also be exported using the **Export** button.

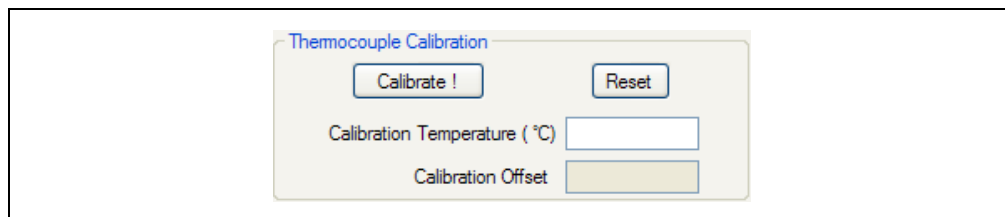

**FIGURE 2-4:** Chart Setup Options.

## 2.3.3 Sensor Calibration and Setup

### 2.3.3.1 THERMOCOUPLE CALIBRATION

The Thermocouple sensor can be calibrated using the GUI. Once the Thermocouple sensor is exposed to the desired calibration temperature, simply type in the temperature in the Calibration Temperature field and click the **Calibrate** button. When the temperature is calibrated and the calibration offset is stored in the PIC Microcontroller EEPROM, the calibration offset is displayed in the RTD Calibration Offset text box. The **Reset** button resets the calibration offset to 0.



**FIGURE 2-5:** Sensor Calibration.

### 2.3.3.2 MCP9804 SETUP

The MCP9804 is a silicon temperature sensor which measures temperature with  $\pm 0.25^{\circ}\text{C}$  nominal and  $\pm 1^{\circ}\text{C}$  maximum accuracy from  $-40^{\circ}\text{C}$  to  $+125^{\circ}\text{C}$ . This sensor has multiple user programmable features such as Alert Output limits, output hysteresis and mode. The output mode can be set up as comparator or interrupt output with an active high or active low levels. The temperature measurement resolution can also be set up.

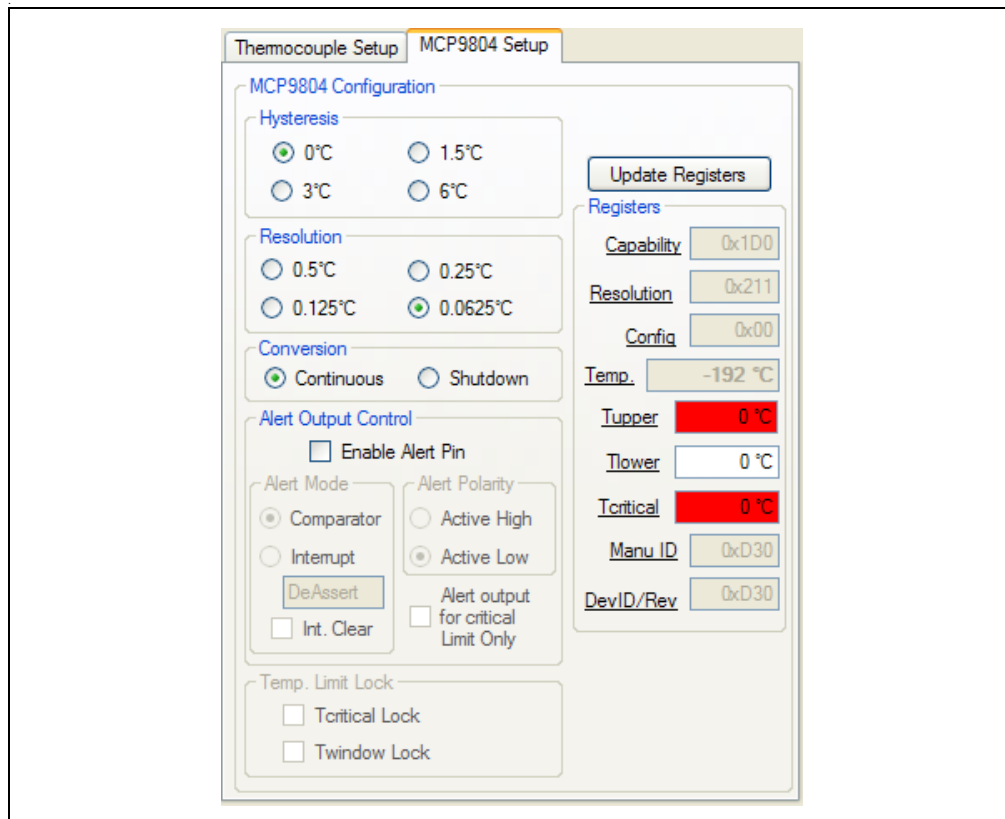

**FIGURE 2-6:** MCP9804 Setup.

# Thermocouple Reference Design

---

NOTES:



---

---

## **Appendix A. Schematic and Layouts**

---

---

### **A.1 INTRODUCTION**

This appendix contains the following schematics and layouts for the Thermocouple Reference Design:

- Board - Schematic
- Board - Top Silk and Pads
- Board - Internal  $V_{DD}$  Layer
- Board - Internal Ground Layer
- Board - Bottom Silk and Pads



## A.3 BOARD - TOP SILK AND PADS

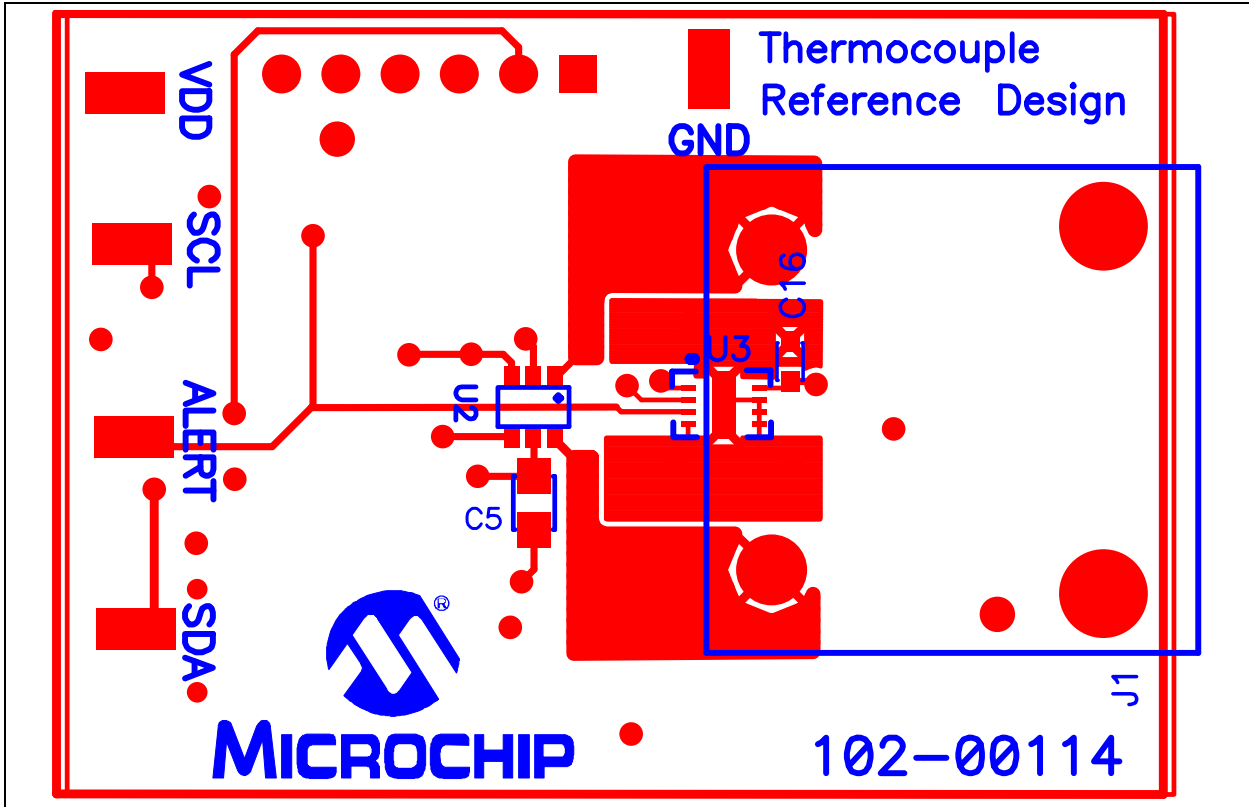

## A.4 BOARD - INTERNAL $V_{DD}$ LAYER

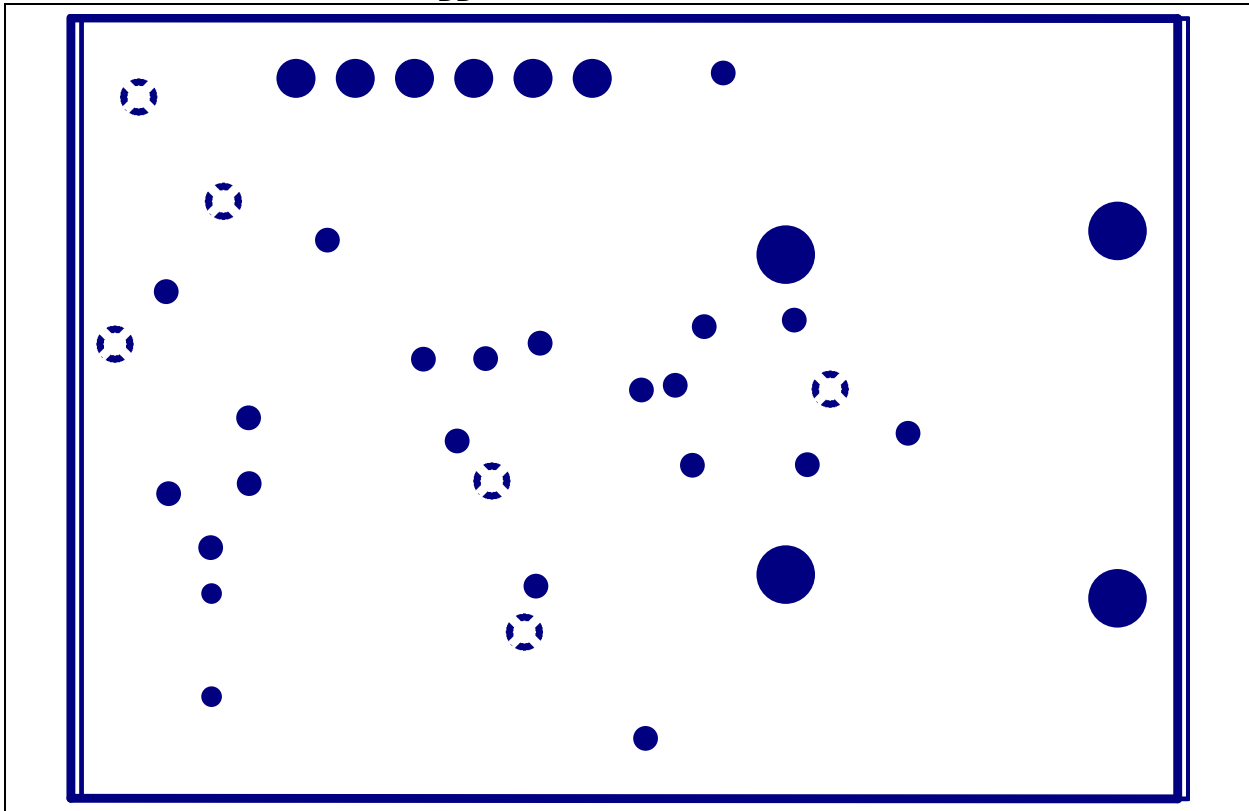

# Thermocouple Reference Design

## A.5 BOARD - INTERNAL GROUND LAYER

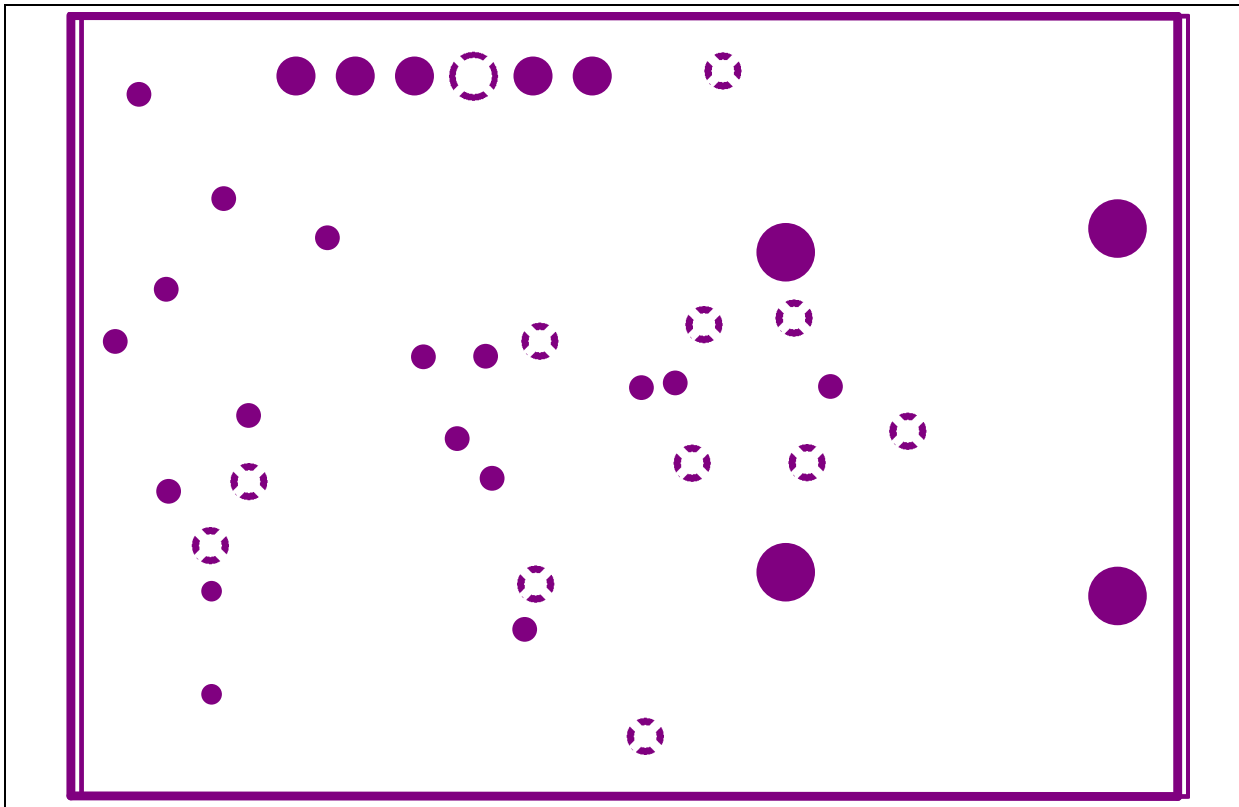

## A.6 BOARD - BOTTOM SILK AND PADS

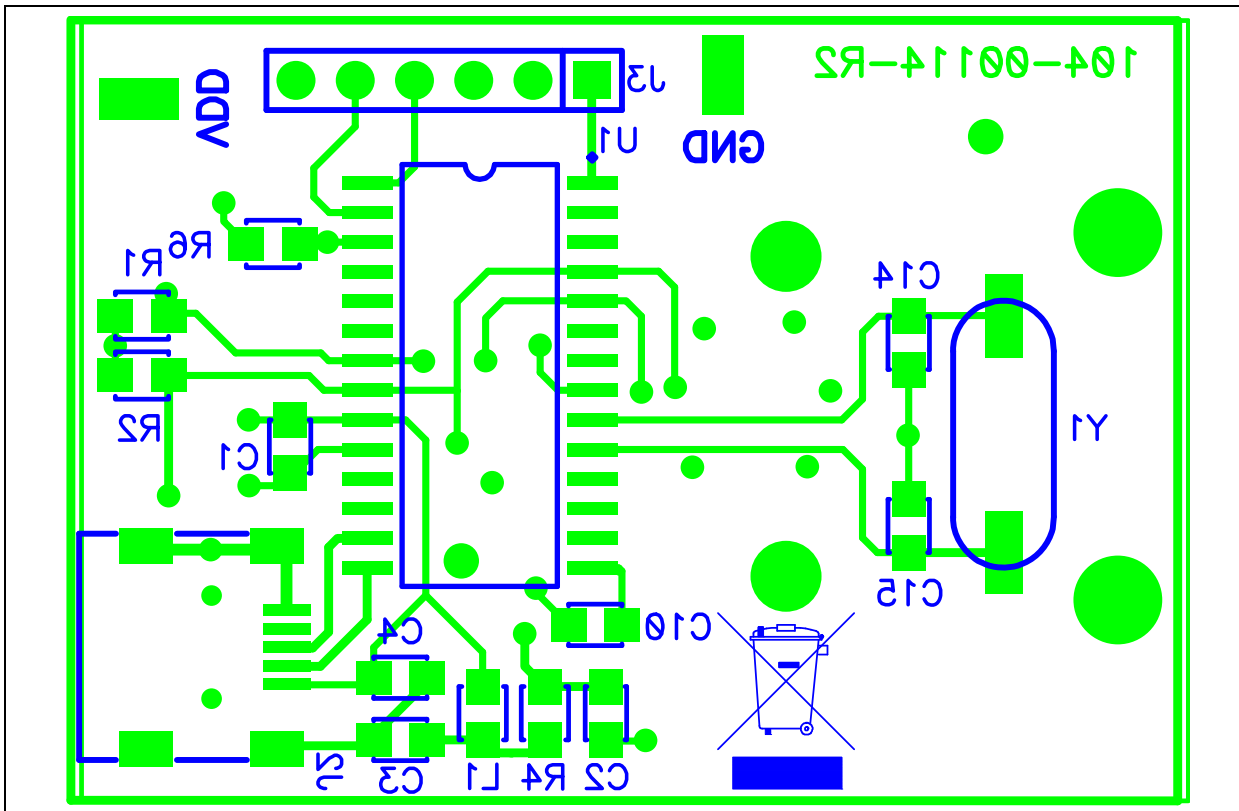

## Appendix B. Bill of Materials

**TABLE B-1: BILL OF MATERIALS**

Qty	Reference Designator	Description	Manufacturer	Manufacturer Part Number
1	—	Ready-Made Insulated Thermocouples with Kapton, PFA, Glass Braid Insulation and Molded Connectors	OMEGA <sup>®</sup>	5SRTC-GG-K-24-36
3	C1, C5, C16	CAP .1UF 25V CERAMIC X7R 0805	Panasonic <sup>®</sup> - ECG	ECJ-2VB1E104K
1	C2	CAP 1.0UF 16V CERAMIC X7R 0805	Kemet <sup>®</sup> Electronics Corp.	C0805C105K4RACTU
2	C3, C4	CAP CER 10UF 16V Y5V 0805	Murata Electronics <sup>®</sup>	GRM21BF51C106ZE15L
1	C10	CAP .47UF 16V CERAMIC X7R 0805	Panasonic - ECG	ECJ-2YB1C474K
2	C14,C15	CAP 22PF 50V CERM CHIP 0805 SMD	Panasonic - ECG	ECJ-2VC1H220J
1	J1	Circuit Board Thermocouple Connectors, Standard PCC-SMP-K-100"	OMEGA	PCC-SMP-K-100
1	J2	CONN MINI USB RCPT RA TYPE B SMD	Tyco <sup>®</sup> Electronics	1734035-2
1	J3	HEADER 1X6 - DO NOT POPULATE	—	—
1	L1	INDUCTOR 10UH 100MA 0805	Murata Electronics	LQM21FN100M70L
1	PCB	RoHS Compliant Bare PCB, Thermocouple Reference Design	Microchip Technology Inc.	104-00114
2	R1, R2	RES 4.99K OHM 1/8W 1% 0805 SMD	Panasonic - ECG	ERJ-6ENF4991V
1	R4	RES 1.0 OHM 1/8W 1% 0805 SMD	Panasonic - ECG	ERJ-6RQF1R0V
1	R6	RES 10.0K OHM 1/8W 1% 0805 SMD	Panasonic - ECG	ERJ-6ENF1002V
7	TP1-TP7	TEST POINT PC COMPACT SMT	Keystone Electronics <sup>®</sup>	5016
1	U1	28/40/44-Pin, High-Performance, Enhanced Flash, USB Microcontrollers with nanoWatt Technology	Microchip Technology Inc.	<b>PIC18F2550-I/SO</b>
1	U2	MCP3421, 18-Bit Analog-to-Digital Converter with I <sup>2</sup> C Interface and On-Board Reference	Microchip Technology Inc.	<b>MCP3421A0T-E/OT</b>
1	U3	MCP9804, Memory Module Digital Temperature Sensor	Microchip Technology Inc.	<b>MCP9804T-E/MC</b>
1	Y1	CRYSTAL 20.0000 MHZ SERIES SMT	CTS-Frequency Controls	ATS200SM

**Note 1:** The components listed in this Bill of Materials are representative of the PCB assembly. The released BOM used in manufacturing uses all RoHS-compliant components.



## WORLDWIDE SALES AND SERVICE

### AMERICAS

**Corporate Office**  
2355 West Chandler Blvd.  
Chandler, AZ 85224-6199  
Tel: 480-792-7200  
Fax: 480-792-7277  
Technical Support:  
<http://support.microchip.com>  
Web Address:  
[www.microchip.com](http://www.microchip.com)

**Atlanta**  
Duluth, GA  
Tel: 678-957-9614  
Fax: 678-957-1455

**Boston**  
Westborough, MA  
Tel: 774-760-0087  
Fax: 774-760-0088

**Chicago**  
Itasca, IL  
Tel: 630-285-0071  
Fax: 630-285-0075

**Cleveland**  
Independence, OH  
Tel: 216-447-0464  
Fax: 216-447-0643

**Dallas**  
Addison, TX  
Tel: 972-818-7423  
Fax: 972-818-2924

**Detroit**  
Farmington Hills, MI  
Tel: 248-538-2250  
Fax: 248-538-2260

**Kokomo**  
Kokomo, IN  
Tel: 765-864-8360  
Fax: 765-864-8387

**Los Angeles**  
Mission Viejo, CA  
Tel: 949-462-9523  
Fax: 949-462-9608

**Santa Clara**  
Santa Clara, CA  
Tel: 408-961-6444  
Fax: 408-961-6445

**Toronto**  
Mississauga, Ontario,  
Canada  
Tel: 905-673-0699  
Fax: 905-673-6509

### ASIA/PACIFIC

**Asia Pacific Office**  
Suites 3707-14, 37th Floor  
Tower 6, The Gateway  
Harbour City, Kowloon  
Hong Kong  
Tel: 852-2401-1200  
Fax: 852-2401-3431

**Australia - Sydney**  
Tel: 61-2-9868-6733  
Fax: 61-2-9868-6755

**China - Beijing**  
Tel: 86-10-8528-2100  
Fax: 86-10-8528-2104

**China - Chengdu**  
Tel: 86-28-8665-5511  
Fax: 86-28-8665-7889

**China - Chongqing**  
Tel: 86-23-8980-9588  
Fax: 86-23-8980-9500

**China - Hong Kong SAR**  
Tel: 852-2401-1200  
Fax: 852-2401-3431

**China - Nanjing**  
Tel: 86-25-8473-2460  
Fax: 86-25-8473-2470

**China - Qingdao**  
Tel: 86-532-8502-7355  
Fax: 86-532-8502-7205

**China - Shanghai**  
Tel: 86-21-5407-5533  
Fax: 86-21-5407-5066

**China - Shenyang**  
Tel: 86-24-2334-2829  
Fax: 86-24-2334-2393

**China - Shenzhen**  
Tel: 86-755-8203-2660  
Fax: 86-755-8203-1760

**China - Wuhan**  
Tel: 86-27-5980-5300  
Fax: 86-27-5980-5118

**China - Xian**  
Tel: 86-29-8833-7252  
Fax: 86-29-8833-7256

**China - Xiamen**  
Tel: 86-592-2388138  
Fax: 86-592-2388130

**China - Zhuhai**  
Tel: 86-756-3210040  
Fax: 86-756-3210049

### ASIA/PACIFIC

**India - Bangalore**  
Tel: 91-80-3090-4444  
Fax: 91-80-3090-4080

**India - New Delhi**  
Tel: 91-11-4160-8631  
Fax: 91-11-4160-8632

**India - Pune**  
Tel: 91-20-2566-1512  
Fax: 91-20-2566-1513

**Japan - Yokohama**  
Tel: 81-45-471- 6166  
Fax: 81-45-471-6122

**Korea - Daegu**  
Tel: 82-53-744-4301  
Fax: 82-53-744-4302

**Korea - Seoul**  
Tel: 82-2-554-7200  
Fax: 82-2-558-5932 or  
82-2-558-5934

**Malaysia - Kuala Lumpur**  
Tel: 60-3-6201-9857  
Fax: 60-3-6201-9859

**Malaysia - Penang**  
Tel: 60-4-227-8870  
Fax: 60-4-227-4068

**Philippines - Manila**  
Tel: 63-2-634-9065  
Fax: 63-2-634-9069

**Singapore**  
Tel: 65-6334-8870  
Fax: 65-6334-8850

**Taiwan - Hsin Chu**  
Tel: 886-3-6578-300  
Fax: 886-3-6578-370

**Taiwan - Kaohsiung**  
Tel: 886-7-536-4818  
Fax: 886-7-536-4803

**Taiwan - Taipei**  
Tel: 886-2-2500-6610  
Fax: 886-2-2508-0102

**Thailand - Bangkok**  
Tel: 66-2-694-1351  
Fax: 66-2-694-1350

### EUROPE

**Austria - Wels**  
Tel: 43-7242-2244-39  
Fax: 43-7242-2244-393

**Denmark - Copenhagen**  
Tel: 45-4450-2828  
Fax: 45-4485-2829

**France - Paris**  
Tel: 33-1-69-53-63-20  
Fax: 33-1-69-30-90-79

**Germany - Munich**  
Tel: 49-89-627-144-0  
Fax: 49-89-627-144-44

**Italy - Milan**  
Tel: 39-0331-742611  
Fax: 39-0331-466781

**Netherlands - Drunen**  
Tel: 31-416-690399  
Fax: 31-416-690340

**Spain - Madrid**  
Tel: 34-91-708-08-90  
Fax: 34-91-708-08-91

**UK - Wokingham**  
Tel: 44-118-921-5869  
Fax: 44-118-921-5820



Компания «ЭлектроПласт» предлагает заключение долгосрочных отношений при поставках импортных электронных компонентов на взаимовыгодных условиях!

Наши преимущества:

- Оперативные поставки широкого спектра электронных компонентов отечественного и импортного производства напрямую от производителей и с крупнейших мировых складов;
- Поставка более 17-ти миллионов наименований электронных компонентов;
- Поставка сложных, дефицитных, либо снятых с производства позиций;
- Оперативные сроки поставки под заказ (от 5 рабочих дней);
- Экспресс доставка в любую точку России;
- Техническая поддержка проекта, помощь в подборе аналогов, поставка прототипов;
- Система менеджмента качества сертифицирована по Международному стандарту ISO 9001;
- Лицензия ФСБ на осуществление работ с использованием сведений, составляющих государственную тайну;
- Поставка специализированных компонентов (Xilinx, Altera, Analog Devices, Intersil, Interpoint, Microsemi, Aeroflex, Peregrine, Syfer, Eurofarad, Texas Instrument, Miteq, Cobham, E2V, MA-COM, Hittite, Mini-Circuits, General Dynamics и др.);

Помимо этого, одним из направлений компании «ЭлектроПласт» является направление «Источники питания». Мы предлагаем Вам помощь Конструкторского отдела:

- Подбор оптимального решения, техническое обоснование при выборе компонента;
- Подбор аналогов;
- Консультации по применению компонента;
- Поставка образцов и прототипов;
- Техническая поддержка проекта;
- Защита от снятия компонента с производства.



#### Как с нами связаться

**Телефон:** 8 (812) 309 58 32 (многоканальный)

**Факс:** 8 (812) 320-02-42

**Электронная почта:** [org@eplast1.ru](mailto:org@eplast1.ru)

**Адрес:** 198099, г. Санкт-Петербург, ул. Калинина, дом 2, корпус 4, литера А.