



# Notebook CPU Step-Down Controller for Intel Mobile Voltage Positioning (IMVP-II)

## General Description

The MAX1718 step-down controller is intended for core CPU DC-DC converters in notebook computers. It features a dynamically adjustable output, ultra-fast transient response, high DC accuracy, and high efficiency needed for leading-edge CPU core power supplies. Maxim's proprietary Quick-PWM™ quick-response, constant-on-time PWM control scheme handles wide input/output voltage ratios with ease and provides 100ns "instant-on" response to load transients while maintaining a relatively constant switching frequency.

The output voltage can be dynamically adjusted through the 5-bit digital-to-analog converter (DAC) over a 0.6V to 1.75V range. The MAX1718 has an internal multiplexer that accepts three unique 5-bit VID DAC codes corresponding to Performance, Battery, and Suspend modes. Precision slew-rate control provides "just-in-time" arrival at the new DAC setting, minimizing surge currents to and from the battery.

The internal DAC of the MAX1718B is synchronized to the slew-rate clock for improved operation under aggressive power management of newer chipsets and operating systems that can make incomplete mode transitions.

A pair of complementary offset control inputs allows easy compensation for IR drops in PC board traces or creation of a voltage-positioned power supply. Voltage-positioning modifies the load-transient response to reduce output capacitor requirements and total system power dissipation.

Single-stage buck conversion allows these devices to directly step down high-voltage batteries for the highest possible efficiency. Alternatively, two-stage conversion (stepping down the 5V system supply instead of the battery) at a higher switching frequency allows the minimum possible physical size.

The MAX1718 is available in a 28-pin QSOP package.

## Applications

- IMVP-II™ Notebook Computers
- 2-Cell to 4-Cell Li+ Battery to CPU Core Supply Converters
- 5V to CPU Core Supply Converters

*Pin Configuration appears at end of data sheet.*

Quick-PWM is a trademark of Maxim Integrated Products, Inc.  
IMVP-II is a trademark of Intel Corp.



## Features

- ◆ Quick-PWM Architecture
- ◆  $\pm 1\%$   $V_{OUT}$  Accuracy Over Line and Load
- ◆ 5-Bit On-Board DAC with Input Muxes
- ◆ Precision-Adjustable  $V_{OUT}$  Slew Control
- ◆ 0.6V to 1.75V Output Adjust Range
- ◆ Precision Offset Control
- ◆ Supports Voltage-Positioned Applications
- ◆ 2V to 28V Battery Input Range
- ◆ Requires a Separate 5V Bias Supply
- ◆ 200/300/550/1000kHz Switching Frequency
- ◆ Over/Undervoltage Protection
- ◆ Drives Large Synchronous-Rectifier FETs
- ◆ 700 $\mu$ A (typ)  $I_{CC}$  Supply Current
- ◆ 2 $\mu$ A (typ) Shutdown Supply Current
- ◆ 2V  $\pm 1\%$  Reference Output
- ◆ VGATE Blanking During Transition
- ◆ Small 28-Pin QSOP Package

## Ordering Information

PART	TEMP RANGE	PIN-PACKAGE
MAX1718EEI	-40°C to +85°C	28 QSOP
MAX1718BEEI+	-40°C to +85°C	28 QSOP
MAX1718BEEI	-40°C to +85°C	28 QSOP
MAX1718BEEIB+	-40°C to +85°C	28 QSOP

+Denotes lead-free package.

## Minimal Operating Circuit

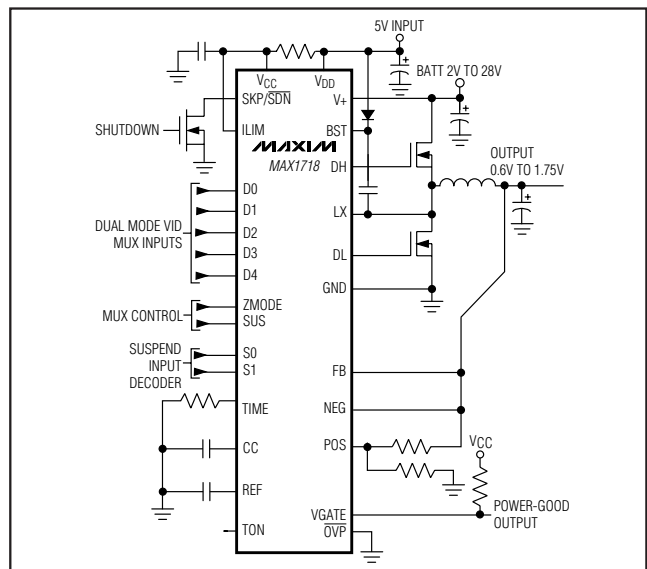

# Notebook CPU Step-Down Controller for Intel Mobile Voltage Positioning (IMVP-II)

## ABSOLUTE MAXIMUM RATINGS

V+ to GND	-0.3V to +30V
V <sub>CC</sub> , V <sub>DD</sub> to GND	-0.3V to +6V
D0-D4, ZMODE, VGATE, OVP, SUS, to GND	-0.3V to +6V
SKP/SDN to GND	-0.3V to +16V
ILIM, CC, REF, POS, NEG, S1, S0, TON, TIME to GND	-0.3V to (V <sub>CC</sub> + 0.3V)
DL to GND	-0.3V to (V <sub>DD</sub> + 0.3V)
BST to GND	-0.3V to +36V
DH to LX	-0.3V to (BST + 0.3V)

LX to BST	-6V to +0.3V
REF Short Circuit to GND	Continuous
Continuous Power Dissipation 28-Pin QSOP (derate 10.8mW/°C above +70°C)	860mW
Operating Temperature Range	-40°C to +85°C
Junction Temperature	+150°C
Storage Temperature	-65°C to +150°C
Lead Temperature (soldering, 10s)	+300°C

Stresses beyond those listed under "Absolute Maximum Ratings" may cause permanent damage to the device. These are stress ratings only, and functional operation of the device at these or any other conditions beyond those indicated in the operational sections of the specifications is not implied. Exposure to absolute maximum rating conditions for extended periods may affect device reliability.

## ELECTRICAL CHARACTERISTICS

(Circuit of Figure 1, V+ = 15V, V<sub>CC</sub> = V<sub>DD</sub> = SKP/SDN = 5V, V<sub>OUT</sub> = 1.25V, T<sub>A</sub> = 0°C to +85°C, unless otherwise noted.)

PARAMETER	CONDITIONS	MIN	TYP	MAX	UNITS		
<b>PWM CONTROLLER</b>							
Input Voltage Range	Battery voltage, V+	2		28	V		
	V <sub>CC</sub> , V <sub>DD</sub>	4.5		5.5			
DC Output Voltage Accuracy	V+ = 4.5V to 28V, includes load regulation error	DAC codes from 0.9V to 1.75V		-1	+1	%	
		DAC codes from 0.6V to 0.875V		-1.5	+1.5	%	
Line Regulation Error	V <sub>CC</sub> = 4.5V to 5.5V, V <sub>BATT</sub> = 4.5V to 28V		5		mV		
Input Bias Current	FB, POS, NEG	-0.2		+0.2	μA		
POS, NEG Common-Mode Range		0.4		2.5	V		
POS, NEG Differential Range	POS - NEG	-80		+80	mV		
POS, NEG Offset Gain	ΔV <sub>FB</sub> / (POS - NEG); POS - NEG = 50mV	0.81	0.86	0.91	V/V		
TIME Frequency Accuracy	150kHz nominal, R <sub>TIME</sub> = 120kΩ	-8		+8	%		
	380kHz nominal, R <sub>TIME</sub> = 47kΩ	-12		+12			
	38kHz nominal, R <sub>TIME</sub> = 470kΩ	-12		+12			
On-Time (Note 1)	V+ = 5V, FB = 1.2V, TON = GND (1000kHz)	230	260	290	ns		
	V+ = 12V, FB = 1.2V	TON = REF (550kHz)		165		190	215
		TON = open (300kHz)		320		355	390
		TON = V <sub>CC</sub> (200kHz)		465		515	565
Minimum Off-Time (Note 1)	TON = V <sub>CC</sub> , open, or REF (200kHz, 300kHz, or 550kHz)		400	500	ns		
	TON = GND (1000kHz)		300	375			
<b>BIAS AND REFERENCE</b>							
Quiescent Supply Current (V <sub>CC</sub> )	Measured at V <sub>CC</sub> , FB forced above the regulation point		700	1200	μA		
Quiescent Supply Current (V <sub>DD</sub> )	Measured at V <sub>DD</sub> , FB forced above the regulation point		<1	5	μA		
Quiescent Battery Supply Current (V+)			25	40	μA		
Shutdown Supply Current (V <sub>CC</sub> )	SKP/SDN = GND		2	5	μA		
Shutdown Supply Current (V <sub>DD</sub> )	SKP/SDN = GND		<1	5	μA		
Shutdown Battery Supply Current (V+)	SKP/SDN = GND, V <sub>CC</sub> = V <sub>DD</sub> = 0V or 5V		<1	5	μA		
Reference Voltage	V <sub>CC</sub> = 4.5V to 5.5V, no REF load	1.98	2	2.02	V		

# Notebook CPU Step-Down Controller for Intel Mobile Voltage Positioning (IMVP-II)

MAX1718

## ELECTRICAL CHARACTERISTICS (continued)

(Circuit of Figure 1,  $V_+ = 15V$ ,  $V_{CC} = V_{DD} = \overline{SKP/SDN} = 5V$ ,  $V_{OUT} = 1.25V$ ,  $T_A = 0^\circ C$  to  $+85^\circ C$ , unless otherwise noted.)

PARAMETER	CONDITIONS	MIN	TYP	MAX	UNITS	
Reference Load Regulation	$I_{REF} = 0\mu A$ to $50\mu A$			0.01	V	
REF Sink Current	REF in regulation	10			$\mu A$	
<b>FAULT PROTECTION</b>						
Oversvoltage Trip Threshold	Measured at FB	1.95	2.00	2.05	V	
Oversvoltage Fault Propagation Delay	FB forced 2% above trip threshold		10		$\mu s$	
Output Undervoltage Fault Protection Threshold	With respect to unloaded output voltage	65	70	75	%	
Output Undervoltage Fault Propagation Delay	FB forced 2% below trip threshold		10		$\mu s$	
Output Undervoltage Fault Blanking Time	From $\overline{SKP/SDN}$ signal going high, clock speed set by $R_{TIME}$		256		clks	
Current-Limit Threshold Voltage (Positive, Default)	GND - LX, $ILIM = V_{CC}$	$T_A = +25^\circ C$ to $+85^\circ C$	90	100	110	mV
		$T_A = 0^\circ C$ to $+85^\circ C$	85		115	
Current-Limit Threshold Voltage (Positive, Adjustable)	GND - LX	$ILIM = 0.5V$	35	50	65	mV
		$ILIM = REF (2V)$	165	200	230	
Current-Limit Threshold Voltage (Negative)	LX - GND, $ILIM = V_{CC}$	-140	-117	-95	mV	
Current-Limit Threshold Voltage (Zero Crossing)	GND - LX		4		mV	
Current-Limit Default Switchover Threshold		3	$V_{CC} - 1$	$V_{CC} - 0.4$	V	
Thermal Shutdown Threshold	Hysteresis = $10^\circ C$		150		$^\circ C$	
$V_{CC}$ Undervoltage Lockout Threshold	Rising edge, hysteresis = 20mV, PWM disabled below this level	4.1		4.4	V	
VGATE Lower Trip Threshold	Measured at FB with respect to unloaded output voltage	-12	-10	-8	%	
VGATE Upper Trip Threshold	Measured at FB with respect to unloaded output voltage	+8	+10	+12	%	
VGATE Propagation Delay	FB forced 2% outside VGATE trip threshold		10		$\mu s$	
VGATE Output Low Voltage	$I_{SINK} = 1mA$			0.4	V	
VGATE Leakage Current	High state, forced to 5.5V			1	$\mu A$	
<b>GATE DRIVERS</b>						
DH Gate Driver On-Resistance	BST - LX forced to 5V		1.0	3.5	$\Omega$	
DL Gate Driver On-Resistance	DL, high state (pullup)		1.0	3.5	$\Omega$	
	DL, low state (pulldown)		0.4	1.0		
DH Gate-Driver Source/Sink Current	DH forced to 2.5V, BST - LX forced to 5V		1.6		A	
DL Gate-Driver Sink Current	DL forced to 2.5V		4		A	

# Notebook CPU Step-Down Controller for Intel Mobile Voltage Positioning (IMVP-II)

## ELECTRICAL CHARACTERISTICS (continued)

(Circuit of Figure 1,  $V_+ = 15V$ ,  $V_{CC} = V_{DD} = \overline{SKP/SDN} = 5V$ ,  $V_{OUT} = 1.25V$ ,  $T_A = 0^\circ C$  to  $+85^\circ C$ , unless otherwise noted.)

PARAMETER	CONDITIONS		MIN	TYP	MAX	UNITS
DL Gate-Driver Source Current	DL forced to 2.5V			1.6		A
Dead Time	DL rising			35		ns
	DH rising			26		
<b>LOGIC AND I/O</b>						
Logic Input High Voltage	D0–D4, ZMODE, SUS, $\overline{OVP}$		2.4			V
Logic Input Low Voltage	D0–D4, ZMODE, SUS, $\overline{OVP}$				0.8	V
DAC B-Mode Programming Resistor, Low	D0–D4, 0 to 0.4V or 2.6V to 5.5V applied through resistor, ZMODE = $V_{CC}$				1.05	k $\Omega$
DAC B-Mode Programming Resistor, High	D0–D4, 0 to 0.4V or 2.6V to 5.5V applied through resistor, ZMODE = $V_{CC}$		95			k $\Omega$
D0–D4 Pullup/Pulldown	Entering impedance mode	Pullup		40		k $\Omega$
		Pulldown		8		
Logic Input Current	D0–D4, ZMODE = GND		-1		+1	$\mu A$
	ZMODE, SUS, $\overline{OVP}$		-1		+1	
4 Level Input Logic Levels (TON, S0, S1)	For high		$V_{CC} - 0.4$			V
	For open		3.15		3.85	
	For REF		1.65		2.35	
	For low				0.5	
SKP/ $\overline{SDN}$ , S0, S1, and TON Input Current	SKP/ $\overline{SDN}$ , S0, S1, TON forced to GND or $V_{CC}$		-3		+3	$\mu A$
SKP/ $\overline{SDN}$ Input Levels	SKP/ $\overline{SDN}$ = logic high (SKIP mode)		2.8		6	V
	SKP/ $\overline{SDN}$ = open (PWM mode)		1.4		2.2	
	SKP/ $\overline{SDN}$ = logic low (shutdown mode)				0.5	
	To enable no-fault mode		12		15	
SKP/ $\overline{SDN}$ Float Level	$I_{SKP/\overline{SDN}} = 0\mu A$		1.8		2.2	V

## ELECTRICAL CHARACTERISTICS

(Circuit of Figure 1,  $V_+ = 15V$ ,  $V_{CC} = V_{DD} = \overline{SKP/SDN} = 5V$ ,  $V_{OUT} = 1.25V$ ,  $T_A = -40^\circ C$  to  $+85^\circ C$ , unless otherwise noted.) (Note 2)

PARAMETER	CONDITIONS		MIN	TYP	MAX	UNITS
<b>PWM CONTROLLER</b>						
DC Output Voltage Accuracy	$V_+ = 4.5V$ to $28V$ , includes load regulation error	DAC codes from 0.9V to 1.75V	-1.5		+1.5	%
		DAC codes from 0.6V to 0.875V	-2.0		+2.0	
TIME Frequency Accuracy	150kHz nominal, $R_{TIME} = 120k\Omega$		-8		+8	%
	380kHz nominal, $R_{TIME} = 47k\Omega$		-12		+12	
	38kHz nominal, $R_{TIME} = 470k\Omega$		-12		+12	
On-Time (Note 1)	$V_+ = 5V$ , FB = 1.2V, TON = GND (1000kHz)		230		290	ns
	$V_+ = 12V$ , FB = 1.2V	TON = REF (550kHz)	165		215	
		TON = open (300kHz)	320		390	
		TON = $V_{CC}$ (200kHz)	465		565	

# Notebook CPU Step-Down Controller for Intel Mobile Voltage Positioning (IMVP-II)

MAX1718

## ELECTRICAL CHARACTERISTICS (continued)

(Circuit of Figure 1,  $V_+ = 15V$ ,  $V_{CC} = V_{DD} = \overline{SKP}/\overline{SDN} = 5V$ ,  $V_{OUT} = 1.25V$ ,  $T_A = -40^\circ C$  to  $+85^\circ C$ , unless otherwise noted.) (Note 2)

PARAMETER	CONDITIONS	MIN	TYP	MAX	UNITS
Minimum Off-Time (Note 1)	$T_{ON} = V_{CC}$ , open, or REF (200kHz, 300kHz, or 550kHz)			500	ns
	$T_{ON} = GND$ (1000kHz)			375	
<b>BIAS AND REFERENCE</b>					
Quiescent Supply Current ( $V_{CC}$ )	Measured at $V_{CC}$ , FB forced above the regulation point			1300	$\mu A$
Quiescent Supply Current ( $V_{DD}$ )	Measured at $V_{DD}$ , FB forced above the regulation point			5	$\mu A$
Quiescent Battery Supply Current ( $V_+$ )				40	$\mu A$
Shutdown Supply Current ( $V_{CC}$ )	$\overline{SKP}/\overline{SDN} = 0$			5	$\mu A$
Shutdown Supply Current ( $V_{DD}$ )	$\overline{SKP}/\overline{SDN} = 0$			5	$\mu A$
Shutdown Battery Supply Current ( $V_+$ )	$\overline{SKP}/\overline{SDN} = 0$ , $V_{CC} = V_{DD} = 0$ or 5V			5	$\mu A$
Reference Voltage	$V_{CC} = 4.5V$ to $5.5V$ , no REF load	1.98		2.02	V
<b>FAULT PROTECTION</b>					
Overvoltage Trip Threshold	Measured at FB	1.95		2.05	V
Output Undervoltage Protection Threshold	With respect to unloaded output voltage	65		75	%
Current-Limit Threshold Voltage (Positive, Default)	GND - LX, $I_{LIM} = V_{CC}$	80		115	mV
Current-Limit Threshold Voltage (Positive, Adjustable)	GND - LX	$I_{LIM} = 0.5V$	33	65	mV
		$I_{LIM} = REF$ (2V)	160	240	
Current-Limit Threshold Voltage (Negative)	LX - GND, $I_{LIM} = V_{CC}$	-145		-90	mV
$V_{CC}$ Undervoltage Lockout Threshold	Rising edge, hysteresis = 20mV, PWM disabled below this level	4.1		4.4	V
VGATE Lower Trip Threshold	Measured at FB with respect to unloaded output voltage	-12.5		-7.5	%
VGATE Upper Trip Threshold	Measured at FB with respect to unloaded output voltage	+7.5		+12.5	%
<b>GATE DRIVERS</b>					
DH Gate Driver On-Resistance	BST - LX forced to 5V			3.5	$\Omega$
DL Gate Driver On-Resistance	DL, high state (pullup)			3.5	$\Omega$
	DL, low state (pulldown)			1.0	

# Notebook CPU Step-Down Controller for Intel Mobile Voltage Positioning (IMVP-II)

## ELECTRICAL CHARACTERISTICS (continued)

(Circuit of Figure 1,  $V_+ = 15V$ ,  $V_{CC} = V_{DD} = \overline{SKP}/\overline{SDN} = 5V$ ,  $V_{OUT} = 1.25V$ ,  $T_A = -40^\circ C$  to  $+85^\circ C$ , unless otherwise noted.) (Note 2)

PARAMETER	CONDITIONS	MIN	TYP	MAX	UNITS
<b>LOGIC AND I/O</b>					
Logic Input High Voltage	D0–D4, ZMODE, SUS, $\overline{OVP}$	2.4			V
Logic Input Low Voltage	D0–D4, ZMODE, SUS, $\overline{OVP}$			0.8	V
DAC B-Mode Programming Resistor, Low	D0–D4, 0 to 0.4V or 2.6V to 5.5V applied through resistor, ZMODE = $V_{CC}$			1.05	$k\Omega$
DAC B-Mode Programming Resistor, High	D0–D4, 0 to 0.4V or 2.6V to 5.5V applied through resistor, ZMODE = $V_{CC}$	95			$k\Omega$

**Note 1:** On-Time specifications are measured from 50% to 50% at the DH pin, with LX forced to 0V, BST forced to 5V, and a 500pF capacitor from DH to LX to simulate external MOSFET gate capacitance. Actual in-circuit times may be different due to MOSFET switching speeds.

**Note 2:** Specifications to  $T_A = -40^\circ C$  are guaranteed by design and not production tested.

## Typical Operating Characteristics

(Circuit of Figure 1,  $V_+ = 12V$ ,  $V_{DD} = V_{CC} = \overline{SKP}/\overline{SDN} = 5V$ ,  $V_{OUT} = 1.25V$ ,  $T_A = +25^\circ C$ , unless otherwise noted.)

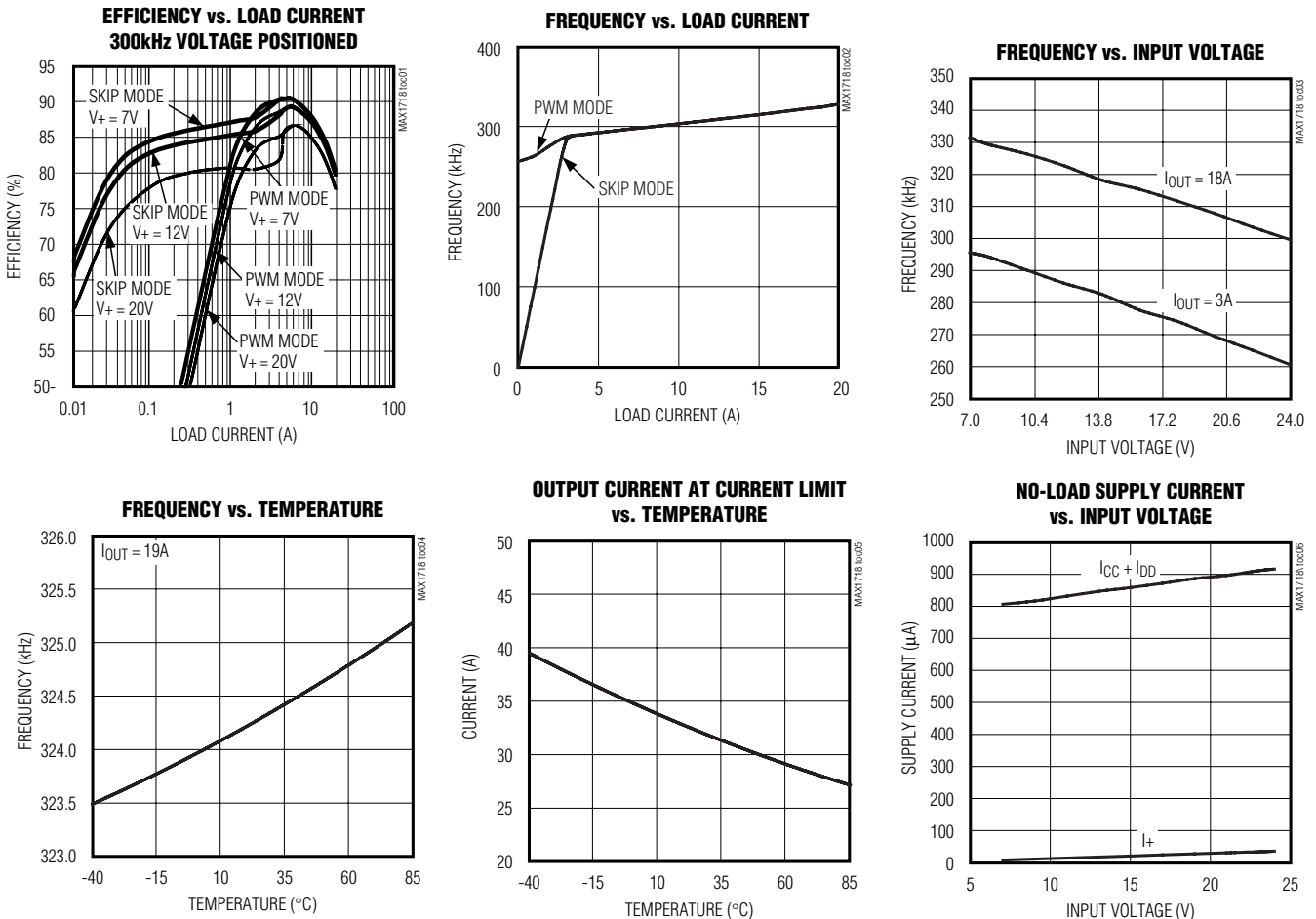

# Notebook CPU Step-Down Controller for Intel Mobile Voltage Positioning (IMVP-II)

MAX1718

## Typical Operating Characteristics (continued)

(Circuit of Figure 1,  $V_+ = 12V$ ,  $V_{DD} = V_{CC} = SKP/\overline{SDN} = 5V$ ,  $V_{OUT} = 1.25V$ ,  $T_A = +25^\circ C$ , unless otherwise noted.)

**NO-LOAD SUPPLY CURRENT vs. INPUT VOLTAGE**

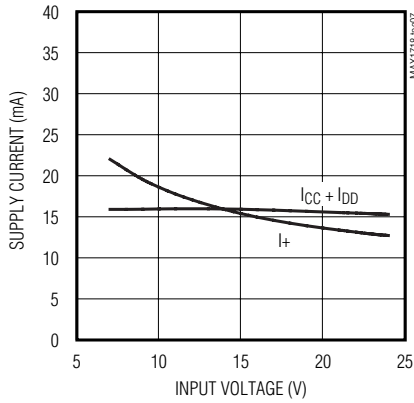

**LOAD-TRANSIENT RESPONSE (SKIP MODE)**

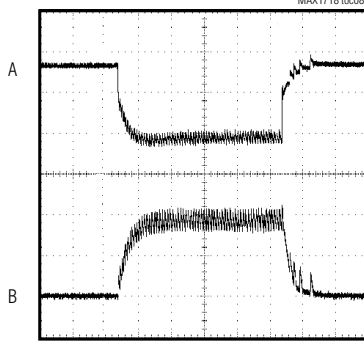

A =  $V_{OUT}$ , 50mV/div, AC-COUPLED  
B = INDUCTOR CURRENT, 10A/div

**LOAD-TRANSIENT RESPONSE (PWM MODE)**

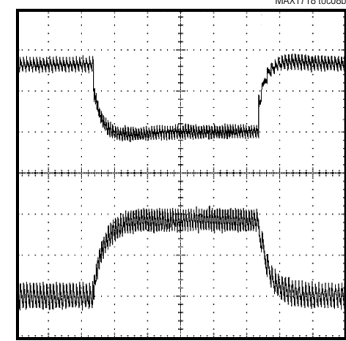

A =  $V_{OUT}$ , 50mV/div, AC-COUPLED  
B = INDUCTOR CURRENT, 10A/div

**STARTUP WAVEFORM (PWM MODE, NO LOAD)**

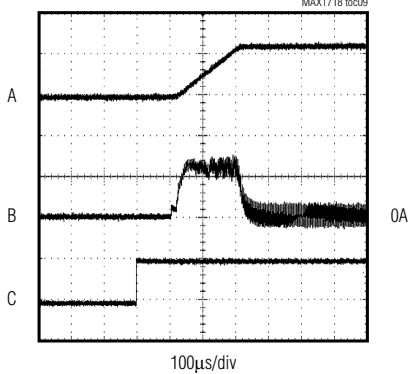

A =  $V_{OUT}$ , 1V/div  
B = INDUCTOR CURRENT, 10A/div  
C = SKP/ $\overline{SDN}$ , 5V/div

**STARTUP WAVEFORM (PWM MODE,  $I_{OUT} = 12A$ )**

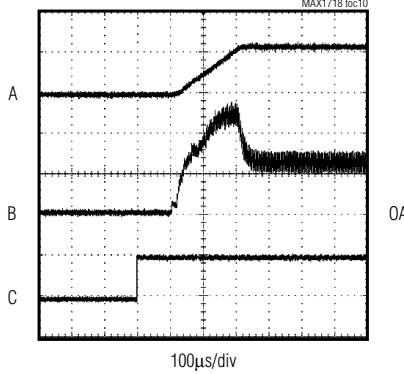

A =  $V_{OUT}$ , 1V/div  
B = INDUCTOR CURRENT, 10A/div  
C = SKP/ $\overline{SDN}$ , 5V/div

**DYNAMIC OUTPUT VOLTAGE TRANSITION (PWM MODE)**

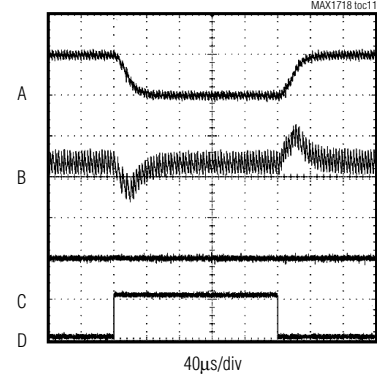

$V_{OUT} = 1.15V$  TO  $1.25V$   
 $I_{OUT} = 3A$ ,  $R_{TIME} = 62k\Omega$   
A =  $V_{OUT}$ , 100mV/div, AC-COUPLED  
B = INDUCTOR CURRENT, 10A/div  
C = VGATE, 5V/div  
D = ZMODE, 5V/div

# Notebook CPU Step-Down Controller for Intel Mobile Voltage Positioning (IMVP-II)

## Typical Operating Characteristics (continued)

(Circuit of Figure 1,  $V_+ = 12V$ ,  $V_{DD} = V_{CC} = SKP/SDN = 5V$ ,  $V_{OUT} = 1.25V$ ,  $T_A = +25^\circ C$ , unless otherwise noted.)

**DYNAMIC OUTPUT VOLTAGE TRANSITION (PWM MODE)**

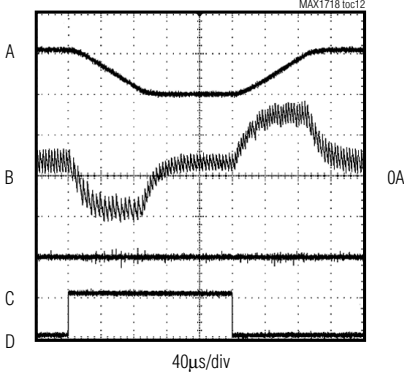

$V_{OUT} = 0.7V$  TO  $1.25V$   
 $I_{OUT} = 3A$ ,  $R_{TIME} = 62k\Omega$   
 A =  $V_{OUT}$ , 500mV/div, AC-COUPLED  
 B = INDUCTOR CURRENT, 10A/div  
 C =  $V_{GATE}$ , 5V/div  
 D =  $SUS$ , 5V/div

**SHUTDOWN WAVEFORM (PWM MODE, NO LOAD)**

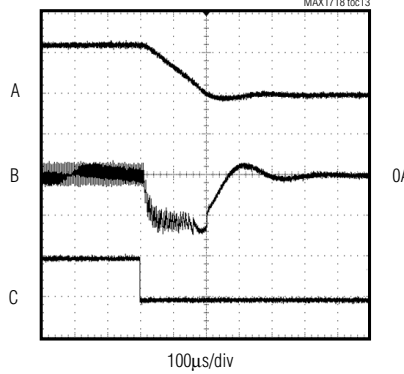

A =  $V_{OUT}$ , 1V/div  
 B = INDUCTOR CURRENT, 10A/div  
 C =  $SKP/SDN$ , 5V/div

**SHUTDOWN WAVEFORM (PWM MODE,  $I_{OUT} = 12A$ )**

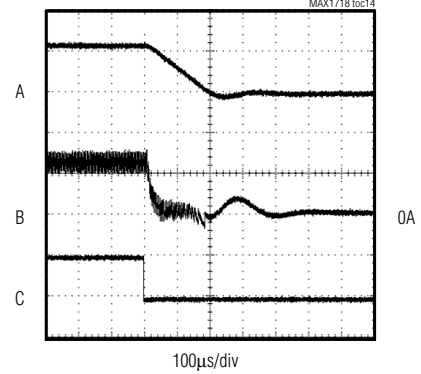

A =  $V_{OUT}$ , 1V/div  
 B = INDUCTOR CURRENT, 10A/div  
 C =  $SKP/SDN$ , 5V/div

**OFFSET FUNCTION SCALE FACTOR vs. DAC SETTING**

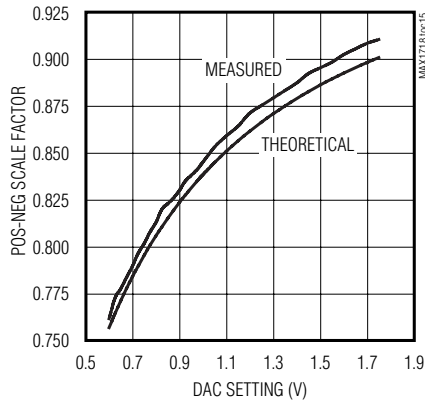

**OUTPUT VOLTAGE vs. POS-NEG DIFFERENTIAL**

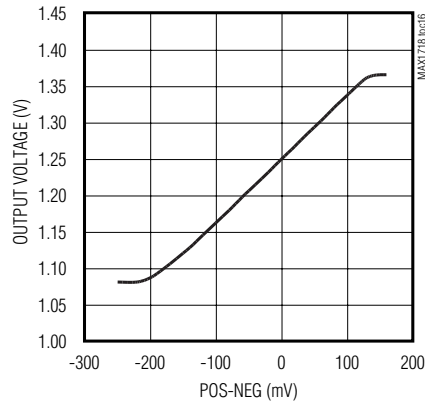



# Notebook CPU Step-Down Controller for Intel Mobile Voltage Positioning (IMVP-II)

MAX1718

## Typical Operating Characteristics (continued)

(Circuit of Figure 1,  $V_+ = 12V$ ,  $V_{DD} = V_{CC} = SKP/\overline{SDN} = 5V$ ,  $V_{OUT} = 1.25V$ ,  $T_A = +25^\circ C$ , unless otherwise noted.)

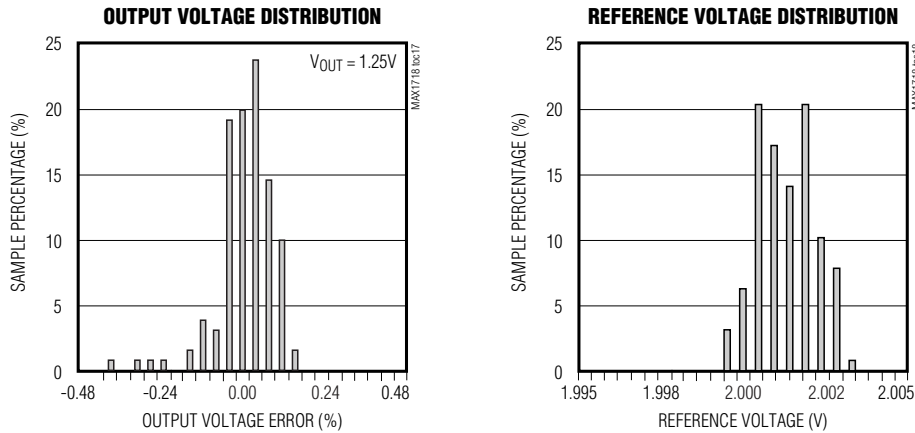

## Pin Description

PIN	NAME	FUNCTION
1	V+	Battery Voltage Sense Connection. Connect V+ to input power source. V+ is used only for PWM one-shot timing. DH on-time is inversely proportional to input voltage over a range of 2V to 28V.
2	SKP/ $\overline{SDN}$	Combined Shutdown and Skip-Mode Control. Drive SKP/ $\overline{SDN}$ to GND for shutdown. Leave SKP/ $\overline{SDN}$ open for low-noise forced-PWM mode, or drive to $V_{CC}$ for pulse-skipping operation. Low-noise forced-PWM mode causes inductor current recirculation at light loads and suppresses pulse-skipping operation. Forcing SKP/ $\overline{SDN}$ to 12V to 15V disables both the overvoltage protection and undervoltage protection circuits and clears the fault latch, with otherwise normal pulse-skipping operation. Do not connect SKP/ $\overline{SDN}$ to > 15V.
3	TIME	Slew-Rate Adjustment Pin. Connect a resistor from TIME to GND to set the internal slew-rate clock. A 470k $\Omega$ to 47k $\Omega$ resistor sets the clock from 38kHz to 380kHz, $f_{SLEW} = 150kHz \times 120k\Omega / R_{TIME}$ .
4	FB	Feedback Input. Connect FB to the junction of the external inductor and the positioning resistor (Figure 1).
5	NEG	Feedback Offset Adjust Negative Input. The output shifts by an amount equal to the difference between POS and NEG multiplied by a scale factor that depends on the DAC codes (see the <i>Integrator Amplifiers/Output Voltage Offsets</i> section). Connect both POS and NEG to REF if the offset function is not used.
6	CC	Integrator Capacitor Connection. Connect a 47pF to 1000pF (47pF typ) capacitor from CC to GND to set the integration time constant (see the <i>Integrator Amplifiers/Output Voltage Offsets</i> section).
7, 8	S0, S1	Suspend-Mode Voltage Select Input. S0 and S1 are four-level digital inputs that select the suspend-mode VID code for the suspend-mode multiplexer inputs. If SUS is high, the suspend-mode VID code is delivered to the DAC (see the <i>Internal Multiplexers (ZMODE/SUS)</i> section).
9	V <sub>CC</sub>	Analog Supply Voltage Input for PWM Core. Connect $V_{CC}$ to the system supply voltage (4.5V to 5.5V) with a series 20 $\Omega$ resistor. Bypass to GND with a 0.22 $\mu F$ (min) capacitor.

# Notebook CPU Step-Down Controller for Intel Mobile Voltage Positioning (IMVP-II)

## Pin Description (continued)

PIN	NAME	FUNCTION
10	TON	On-Time Selection Control Input. This is a four-level input that sets the K factor (Table 2) to determine DH on-time. Connect TON to the following pins for the indicated operation: GND = 100kHz REF = 550kHz Open = 300kHz VCC = 200kHz
11	REF	2V Reference Output. Bypass to GND with 0.22 $\mu$ F (min) capacitor. Can source 50 $\mu$ A for external loads. Loading REF degrades FB accuracy according to the REF load-regulation error.
12	ILIM	Current-Limit Adjustment. The GND - LX current-limit threshold defaults to 100mV if ILIM is connected to VCC. In adjustable mode, the current-limit threshold voltage is 1/10th the voltage seen at ILIM over a 0.5V to 3V range. The logic threshold for switchover to the 100mV default value is approximately VCC - 1V. Connect ILIM to REF for a fixed 200mV threshold.
13	POS	Feedback Offset Adjust Negative Input. The output shifts by an amount equal to the difference between POS and NEG multiplied by a scale factor that depends on the DAC codes (see the <i>Integrator Amplifiers/Output Voltage Offsets</i> section). Connect both POS and NEG to REF if the offset function is not used.
14	VGATE	Open-Drain Power-Good Output. VGATE is normally high when the output is in regulation. If VFB is not within a $\pm 10\%$ window of the DAC setting, VGATE is asserted low. During DAC code transitions, VGATE is forced high until 1 clock period after the slew-rate controller finishes the transition. VGATE is low during shutdown.
15	GND	Analog and Power Ground. Also connects to the current-limit comparator.
16	DL	Low-Side Gate Driver Output. DL swings GND to VDD.
17	VDD	Supply Voltage Input for the DL Gate Driver, 4.5V to 5.5V. Bypass to GND with a 1 $\mu$ F capacitor.
18	SUS	Suspend-Mode Control Input. When SUS is high, the suspend-mode VID code, as programmed by S0 and S1, is delivered to the DAC. Connect SUS to GND if the Suspend-mode multiplexer is not used (see the <i>Internal Multiplexers (ZMODE/SUS)</i> section).
19	ZMODE	Performance-Mode MUX Control Input. If SUS is low, ZMODE selects between two different VID DAC codes. If ZMODE is low, the VID DAC code is set by the logic-level voltages on D0–D4. On the rising edge of ZMODE, during power-up with ZMODE high, or on the falling edge of SUS when ZMODE is high, the VID DAC code is determined by the impedance at D0–D4 (see the <i>Internal Multiplexers (ZMODE/SUS)</i> section).
20	$\overline{\text{OVP}}$	Overvoltage Protection Control Input. Connect $\overline{\text{OVP}}$ low to enable overvoltage protection. Connect $\overline{\text{OVP}}$ high to disable overvoltage protection. The overvoltage trip threshold is approximately 2V. The state of $\overline{\text{OVP}}$ does not affect output undervoltage fault protection or thermal shutdown.
21–25	D4–D0	VID DAC Code Inputs. D0 is the LSB, and D4 is the MSB of the internal 5-bit VID DAC (Table 3). If ZMODE is low, D0–D4 are high-impedance digital inputs, and the VID DAC code is set by the logic-level voltages on D0–D4. On the rising edge of ZMODE, during power-up with ZMODE high, or on the falling edge of SUS when ZMODE is high, the VID DAC code is determined by the impedance at D0–D4 as follows: Logic low = source impedance is $\leq 1\text{k}\Omega + 5\%$ . Logic high = source impedance is $\geq 100\text{k}\Omega - 5\%$ .
26	BST	Boost Flying Capacitor Connection. Connect BST to the external boost diode and capacitor as shown in Figure 1. An optional resistor in series with BST allows the DH pullup current to be adjusted (Figure 8).
27	LX	Inductor Connection. LX is the internal lower supply rail for the DH high-side gate driver. It also connects to the current-limit comparator and the skip-mode zero-crossing comparator.
28	DH	High-Side Gate-Driver Output. DH swings LX to BST.



# Notebook CPU Step-Down Controller for Intel Mobile Voltage Positioning (IMVP-II)

Table 1. Component Suppliers

MANUFACTURER	USA PHONE	FACTORY FAX
Central Semiconductor	516-435-1110	516-435-1824
Dale-Vishay	402-564-3131	402-563-6418
Fairchild	408-721-2181	408-721-1635
International Rectifier	310-322-3331	310-322-3332
Kemet	408-986-0424	408-986-1442
Motorola	602-303-5454	602-994-6430
Nihon	847-843-7500	847-843-2798
Panasonic	714-373-7939	714-373-7183
Taiyo Yuden	408-573-4150	408-573-4159
TDK	847-390-4373	847-390-4428
Toko	800-745-8656	408-943-9790
Sanyo	619-661-6835	619-661-1055
SGS-Thomson	617-259-0300	617-259-9442
Sumida	708-956-0666	708-956-0702
Zetex	516-543-7100	516-864-7630

## Detailed Description

### 5V Bias Supply (V<sub>CC</sub> and V<sub>DD</sub>)

The MAX1718 requires an external 5V bias supply in addition to the battery. Typically, this 5V bias supply is the notebook's 95% efficient 5V system supply. Keeping the bias supply external to the IC improves efficiency and eliminates the cost associated with the 5V linear regulator that would otherwise be needed to supply the PWM circuit and gate drivers. If stand-alone capability is needed, the 5V supply can be generated with an external linear regulator.

The 5V bias supply must provide V<sub>CC</sub> (PWM controller) and V<sub>DD</sub> (gate-drive power), so the maximum current drawn is:

$$I_{BIAS} = I_{CC} + f(Q_{G1} + Q_{G2}) = 10\text{mA to }40\text{mA (typ)}$$

where I<sub>CC</sub> is 800μA (typ), f is the switching frequency, and Q<sub>G1</sub> and Q<sub>G2</sub> are the MOSFET data sheet total gate-charge specification limits at V<sub>GS</sub> = 5V.

V<sub>+</sub> and V<sub>DD</sub> can be tied together if the input power source is a fixed 4.5V to 5.5V supply. If the 5V bias supply is powered up prior to the battery supply, the enable signal (SKP/SDN going from low to high or open) must be delayed until the battery voltage is present to ensure startup.

### Free-Running, Constant On-Time PWM Controller with Input Feed-Forward

The Quick-PWM control architecture is a pseudofixed-frequency, constant-on-time current-mode type with voltage feed-forward (Figure 2). This architecture relies on the output filter capacitor's ESR to act as the current-sense resistor, so the output ripple voltage provides the PWM ramp signal. The control algorithm is simple: the high-side switch on-time is determined solely by a one-shot whose period is inversely proportional to input voltage and directly proportional to output voltage. Another one-shot sets a minimum off-time (400ns typ). The on-time one-shot is triggered if the error comparator is low, the low-side switch current is below the current-limit threshold, and the minimum off-time one-shot has timed out.

### On-Time One-Shot (TON)

The heart of the PWM core is the one-shot that sets the high-side switch on-time. This fast, low-jitter, adjustable one-shot includes circuitry that varies the on-time in response to battery and output voltage. The high-side switch on-time is inversely proportional to the battery voltage as measured by the V<sub>+</sub> input, and proportional to the output voltage. This algorithm results in a nearly constant switching frequency despite the lack of a fixed-frequency clock generator. The benefits of a constant switching frequency are twofold: first, the frequency can be selected to avoid noise-sensitive regions such as the 455kHz IF band; second, the inductor ripple-current operating point remains relatively constant, resulting in easy design methodology and predictable output voltage ripple.

$$\text{On-Time} = K (V_{OUT} + 0.075V) / V_{IN}$$

where K is set by the TON pin-strap connection and 0.075V is an approximation to accommodate the expected drop across the low-side MOSFET switch (Table 2).

The on-time one-shot has good accuracy at the operating points specified in the *Electrical Characteristics table* (±10% at 200kHz and 300kHz, ±12% at 550kHz and 1000kHz). On-times at operating points far removed from the conditions specified in the *Electrical Characteristics table* can vary over a wider range. For example, the 1000kHz setting will typically run about 10% slower with inputs much greater than +5V due to the very short on-times required.

On-times translate only roughly to switching frequencies. The on-times guaranteed in the *Electrical Characteristics table* are influenced by switching delays in the

# Notebook CPU Step-Down Controller for Intel Mobile Voltage Positioning (IMVP-II)

MAX1718

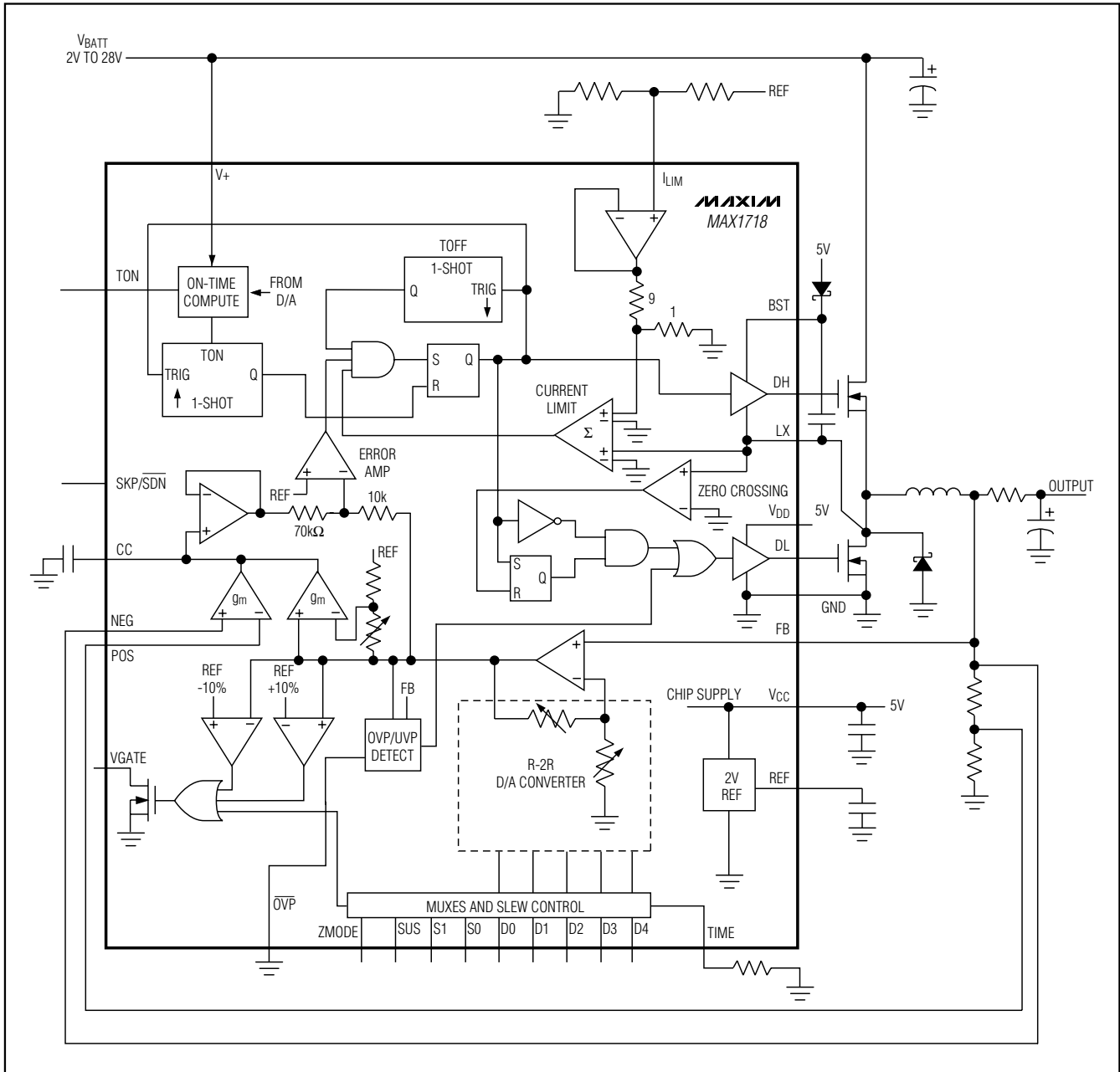

Figure 2. Functional Diagram

# Notebook CPU Step-Down Controller for Intel Mobile Voltage Positioning (IMVP-II)

Table 2. Approximate K-Factor Errors

TON SETTING	TON FREQUENCY (kHz)	K-FACTOR (μs)	APPROXIMATE K-FACTOR ERROR (%)	MIN RECOMMENDED V <sub>BATT</sub> AT	
				V <sub>OUT</sub> = 1.25V (V)	V <sub>OUT</sub> = 1.75V (V)
V <sub>CC</sub>	200	5	±10	1.7	2.3
OPEN	300	3.3	±10	1.8	2.5
REF	550	1.8	±12.5	2.6	3.5
GND	1000	1.0	±12.5	3.6	4.9

external high-side MOSFET. Resistive losses, including the inductor, both MOSFETs, output capacitor ESR, and PC board copper losses in the output and ground tend to raise the switching frequency at higher output currents. Also, the dead-time effect increases the effective on-time, reducing the switching frequency. It occurs only in PWM mode (SKP/SDN = open) and during dynamic output voltage transitions when the inductor current reverses at light or negative load currents. With reversed inductor current, the inductor's EMF causes LX to go high earlier than normal, extending the on-time by a period equal to the DH-rising dead time.

For loads above the critical conduction point, where the dead-time effect is no longer a factor, the actual switching frequency is:

$$f = \frac{(V_{OUT} + V_{DROP1})}{t_{ON}(V_{IN} + V_{DROP1} - V_{DROP2})}$$

where V<sub>DROP1</sub> is the sum of the parasitic voltage drops in the inductor discharge path, including synchronous rectifier, inductor, and PC board resistances; V<sub>DROP2</sub> is the sum of the parasitic voltage drops in the inductor charge path, including high-side switch, inductor, and PC board resistances; and t<sub>ON</sub> is the on-time calculated by the MAX1718.

### Integrator Amplifiers/Output Voltage Offsets

Two transconductance integrator amplifiers provide a fine adjustment to the output regulation point. One amplifier forces the DC average of the feedback voltage to equal the VID DAC setting. The second amplifier is used to create small positive or negative offsets from the VID DAC setting, using the POS and NEG pins.

The integrator block has the ability to lower the output voltage by 8% and raise it by 8%. For each amplifier, the differential input voltage range is at least ±80mV total, including DC offset and AC ripple. The two amplifiers' outputs are directly summed inside the chip, so the integration time constant can be set easily with one capacitor at the CC pin. Use a capacitor value of 47pF

to 1000pF (47pF typ). The g<sub>m</sub> of each amplifier is 160μmho (typ).

The POS/NEG amplifier is used to add small offsets to the VID DAC setting or to correct for voltage drops. To create an output offset, bias POS and NEG to a voltage (typically V<sub>OUT</sub> or REF) within their common-mode range, and offset them from one another with a resistive divider (Figures 3 and 4). If V<sub>POS</sub> is higher than V<sub>NEG</sub>, then the output is shifted in the positive direction. If V<sub>NEG</sub> is higher than V<sub>POS</sub>, then the output is shifted in the negative direction. The amount of output offset is less than the difference from POS to NEG by a scale factor that varies with the VID DAC setting as shown in Table 3. The common-mode range of POS and NEG is 0.4V to 2.5V.

For applications that require multiple offsets, an external multiplexer can be used to select various resistor values (Figure 5).

Both the integrator amplifiers can be disabled by connecting NEG to V<sub>CC</sub>.

### Forced-PWM Mode (SKP/SDN Open)

The low-noise forced-PWM mode (SKP/SDN open) disables the zero-crossing comparator, allowing the inductor current to reverse at light loads. This causes the low-side gate-drive waveform to become the complement of the high-side gate-drive waveform. The benefit of forced-PWM mode is to keep the switching frequency fairly constant, but it comes at a cost: the no-load battery current can be 10mA to 40mA, depending on the external MOSFETs and switching frequency.

Forced-PWM mode is required during downward output voltage transitions. The MAX1718 uses PWM mode during all transitions, but only while the slew-rate controller is active. Due to voltage positioning, when a transition uses high negative inductor current, the output voltage does not settle to its final intended value until well after the slew-rate controller terminates. Because of this it is possible, at very high negative slew currents, for the output to end up high enough to cause VGATE to go low.

# Notebook CPU Step-Down Controller for Intel Mobile Voltage Positioning (IMVP-II)

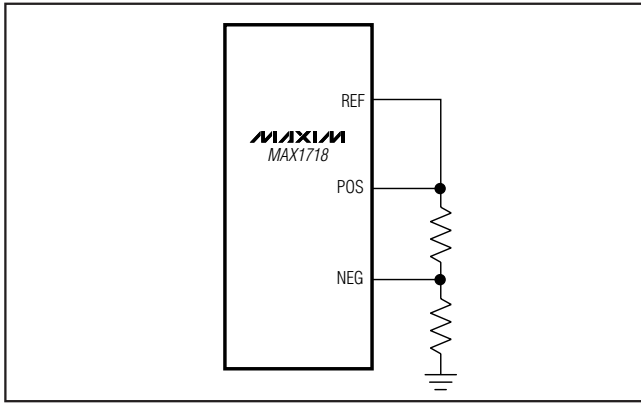

Figure 3. Resistive Divider from REF

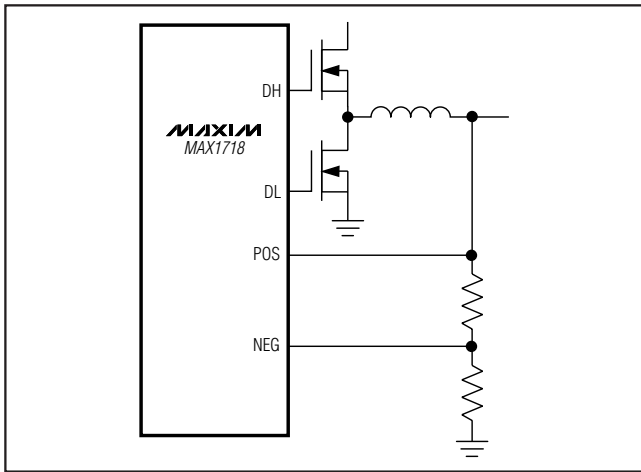

Figure 4. Resistive Divider from OUTPUT

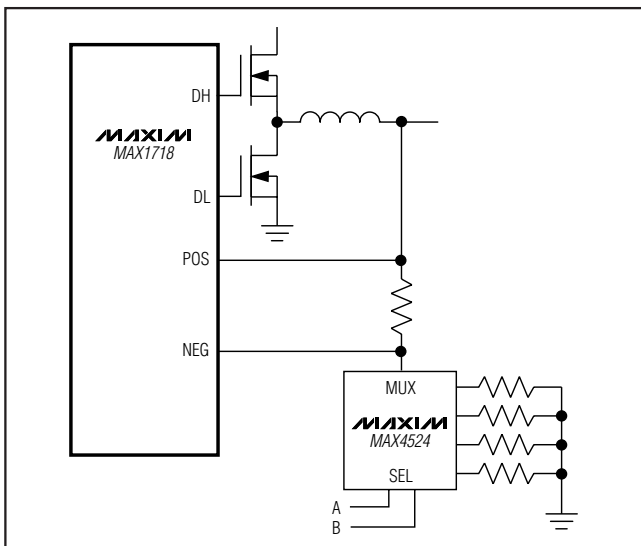

Figure 5. Programmable Offset Voltage

Thus, it is necessary to use forced PWM mode during all negative transitions. Most applications should use PWM mode exclusively, although there is some benefit to using skip mode while in the low-power suspend state (see the *Using Skip Mode During Suspend (SKP/SDN = VCC)* section.)

### Automatic Pulse-Skipping Switchover

In skip mode (SKP/SDN high), an inherent automatic switchover to PFM takes place at light loads (Figure 6). This switchover is effected by a comparator that truncates the low-side switch on-time at the inductor current's zero crossing. This mechanism causes the threshold between pulse-skipping PFM and nonskipping PWM operation to coincide with the boundary between continuous and discontinuous inductor-current operation. The load-current level at which PFM/PWM crossover occurs,  $I_{LOAD(SKIP)}$ , is equal to 1/2 the peak-to-peak ripple current, which is a function of the inductor value (Figure 6). For a battery range of 7V to 24V, this threshold is relatively constant, with only a minor dependence on battery voltage:

$$I_{LOAD(SKIP)} \approx \frac{K \times V_{OUT}}{2 \times L} \times \frac{V_{BATT} - V_{OUT}}{V_{BATT}}$$

where K is the on-time scale factor (Table 2). For example, in the standard application circuit this becomes:

$$\frac{3.3\mu s \times 1.25V}{2 \times 0.68\mu H} \times \frac{12V - 1.25V}{12V} = 2.7A$$

The crossover point occurs at a lower value if a swinging (soft-saturation) inductor is used.

The switching waveforms may appear noisy and asynchronous when light loading causes pulse-skipping operation, but this is a normal operating condition that results in high light-load efficiency. Trade-offs in PFM noise vs. light-load efficiency are made by varying the inductor value. Generally, low inductor values produce a broader efficiency vs. load curve, while higher values result in higher full-load efficiency (assuming that the coil resistance remains fixed) and less output voltage ripple. Penalties for using higher inductor values include larger physical size and degraded load-transient response, especially at low input voltage levels.

### Current-Limit Circuit

The current-limit circuit employs a unique "valley" current-sensing algorithm that uses the on-resistance of the low-side MOSFET as a current-sensing element. If the current-sense signal is above the current-limit threshold, the PWM is not allowed to initiate a new cycle

# Notebook CPU Step-Down Controller for Intel Mobile Voltage Positioning (IMVP-II)

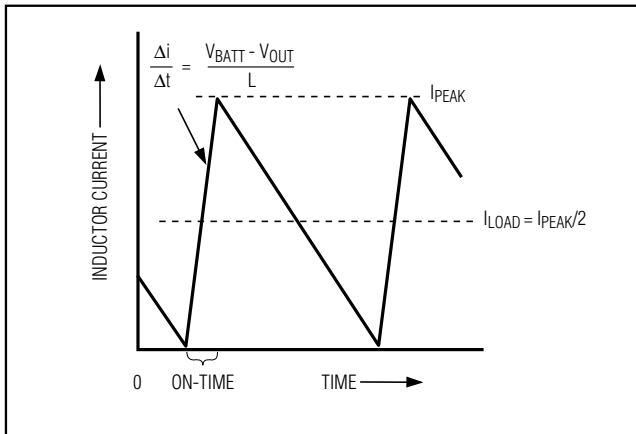

Figure 6. Pulse-Skipping/Discontinuous Crossover Point

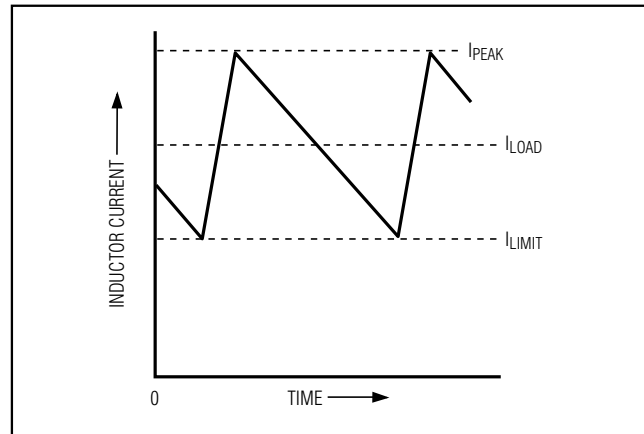

Figure 7. "Valley" Current-Limit Threshold Point

(Figure 7). The actual peak current is greater than the current-limit threshold by an amount equal to the inductor ripple current. Therefore, the exact current-limit characteristic and maximum load capability are a function of the MOSFET on-resistance, inductor value, and battery voltage. The reward for this uncertainty is robust, lossless overcurrent sensing. When combined with the undervoltage protection circuit, this current-limit method is effective in almost every circumstance.

There is also a negative current limit that prevents excessive reverse inductor currents when  $V_{OUT}$  is sinking current. The negative current-limit threshold is set to approximately 120% of the positive current limit, and therefore tracks the positive current limit when  $I_{LIM}$  is adjusted.

The current-limit threshold is adjusted with an external resistor-divider at  $I_{LIM}$ . The current-limit threshold voltage adjustment range is from 50mV to 300mV. In the adjustable mode, the current-limit threshold voltage is precisely 1/10th the voltage seen at  $I_{LIM}$ . The threshold defaults to 100mV when  $I_{LIM}$  is connected to  $V_{CC}$ . The logic threshold for switchover to the 100mV default value is approximately  $V_{CC} - 1V$ .

The adjustable current limit accommodates MOSFETs with a wide range of on-resistance characteristics (see the *Design Procedure* section). For a high-accuracy current-limit application, see Figure 16.

Carefully observe the PC board layout guidelines to ensure that noise and DC errors don't corrupt the current-sense signals seen by LX and GND. Place the IC close to the low-side MOSFET with short, direct traces, making a Kelvin sense connection to the source and drain terminals.

## MOSFET Gate Drivers (DH, DL)

The DH and DL drivers are optimized for driving moderate-sized high-side and larger low-side power MOSFETs. This is consistent with the low duty factor seen in the notebook CPU environment, where a large  $V_{BATT} - V_{OUT}$  differential exists. An adaptive dead-time circuit monitors the DL output and prevents the high-side FET from turning on until DL is fully off. There must be a low-resistance, low-inductance path from the DL driver to the MOSFET gate for the adaptive dead-time circuit to work properly. Otherwise, the sense circuitry in the MAX1718 will interpret the MOSFET gate as "off" while there is actually still charge left on the gate. Use very short, wide traces measuring 10 to 20 squares (50 to 100 mils wide if the MOSFET is 1 inch from the MAX1718).

The dead time at the other edge (DH turning off) is determined by a fixed 35ns (typ) internal delay.

The internal pulldown transistor that drives DL low is robust, with a  $0.4\Omega$  (typ) on-resistance. This helps prevent DL from being pulled up during the fast rise-time of the inductor node, due to capacitive coupling from the drain to the gate of the low-side synchronous-rectifier MOSFET. However, for high-current applications, you might still encounter some combinations of high- and low-side FETs that will cause excessive gate-drain coupling, which can lead to efficiency-killing, EMI-producing shoot-through currents. This is often remedied by adding a resistor in series with BST, which increases the turn-on time of the high-side FET without degrading the turn-off time (Figure 8).

## POR

Power-on reset (POR) occurs when  $V_{CC}$  rises above approximately 2V, resetting the fault latch and preparing the PWM for operation.  $V_{CC}$  undervoltage lockout



# Notebook CPU Step-Down Controller for Intel Mobile Voltage Positioning (IMVP-II)

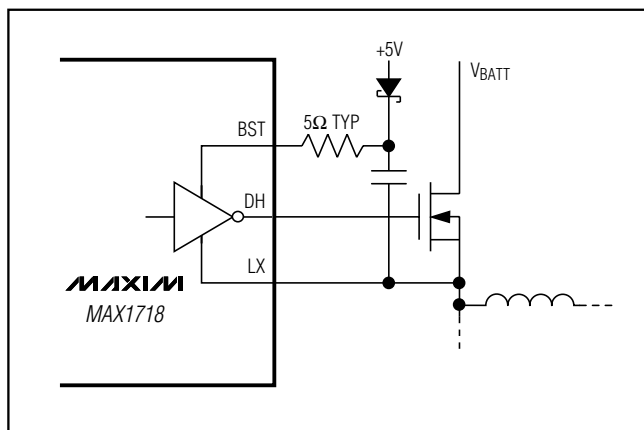

Figure 8. Reducing the Switching-Node Rise Time

(UVLO) circuitry inhibits switching, forces VGATE low, and forces the DL gate driver high (to enforce output overvoltage protection). When VCC rises above 4.2V, the DAC inputs are sampled and the output voltage begins to slew to the DAC setting.

For automatic startup, the battery voltage should be present before VCC. If the MAX1718 attempts to bring the output into regulation without the battery voltage present, the fault latch will trip. The SKP/ $\overline{\text{SDN}}$  pin can be toggled to reset the fault latch.

## Shutdown

When SKP/ $\overline{\text{SDN}}$  goes low, the MAX1718 enters low-power shutdown mode. VGATE goes low immediately. The output voltage ramps down to 0V in 25mV steps at the clock rate set by RTIME. When the DAC reaches the 0V setting, DL goes high, DH goes low, the reference is turned off, and the supply current drops to about 2 $\mu$ A.

When SKP/ $\overline{\text{SDN}}$  goes high or floats, the reference powers up, and after the reference UVLO is passed, the DAC target is evaluated and switching begins. The slew-rate controller ramps up from 0V in 25mV steps to the currently selected code value (based on ZMODE and SUS). There is no traditional soft-start (variable current limit) circuitry, so full output current is available immediately. VGATE goes high after the slew-rate controller has terminated and the output voltage is in regulation.

## UVLO

If VCC drops low enough to trip the UVLO comparator, it is assumed that there is not enough supply voltage to make valid decisions. To protect the output from overvoltage faults, DL is forced high in this mode. This will force the output to GND, but it will not use the slew-rate controller. This results in large negative inductor current

and possibly small negative output voltages. If VCC is likely to drop in this fashion, the output can be clamped with a Schottky diode to GND to reduce the negative excursion.

## DAC Inputs D0–D4

The digital-to-analog converter (DAC) programs the output voltage. It typically receives a preset digital code from the CPU pins, which are either hard-wired to GND or left open-circuit. They can also be driven by digital logic, general-purpose I/O, or an external mux. Do not leave D0–D4 floating—use 1M $\Omega$  or less pullups if the inputs may float. D0–D4 can be changed while the SMPS is active, initiating a transition to a new output voltage level. If this mode of DAC control is used, connect ZMODE and SUS low. Change D0–D4 together, avoiding greater than 1 $\mu$ s skew between bits. Otherwise, incorrect DAC readings may cause a partial transition to the wrong voltage level, followed by the intended transition to the correct voltage level, lengthening the overall transition time. The available DAC codes and resulting output voltages (Table 3) are compatible with IMVP-II specification.

## Internal Multiplexers (ZMODE, SUS)

The MAX1718 has two unique internal VID input multiplexers (muxes) that can select one of three different VID DAC code settings for different processor states. Depending on the logic level at SUS, the Suspend (SUS) mode mux selects the VID DAC code settings from either the ZMODE mux or the S0/S1 input decoder. The ZMODE mux selects one of the two VID DAC code settings from the D0–D4 pins, based on either voltage on the pins or the output of the impedance decoder (Figure 9).

When SUS is high, the Suspend mode mux selects the VID DAC code settings from the S0/S1 input decoder. The outputs of the decoder are determined by inputs S0 and S1 (Table 4).

When SUS is low, the Suspend mode mux selects the output of the ZMODE mux. Depending on the logic level at ZMODE, the ZMODE mux selects the VID DAC code settings using either the voltage on D0–D4 or the output of the impedance decoder (Table 5).

If ZMODE is low, the logic-level voltages on D0–D4 set the VID DAC settings. This is called Logic mode. In this mode, the inputs are continuously active and can be dynamically changed by external logic. The Logic mode VID DAC code setting is typically used for the Battery mode state, and the source of this code is sometimes the VID pins of the CPU with suitable pullup resistors.

# Notebook CPU Step-Down Controller for Intel Mobile Voltage Positioning (IMVP-II)

MAX1718

Table 3. Output Voltage vs. DAC Codes

D4	D3	D2	D1	D0	OUTPUT VOLTAGE (V)	POS/NEG SCALE FACTOR
0	0	0	0	0	1.75	0.90
0	0	0	0	1	1.70	0.90
0	0	0	1	0	1.65	0.90
0	0	0	1	1	1.60	0.89
0	0	1	0	0	1.55	0.89
0	0	1	0	1	1.50	0.89
0	0	1	1	0	1.45	0.88
0	0	1	1	1	1.40	0.88
0	1	0	0	0	1.35	0.88
0	1	0	0	1	1.30	0.87
0	1	0	1	0	1.25	0.87
0	1	0	1	1	1.20	0.86
0	1	1	0	0	1.15	0.86
0	1	1	0	1	1.10	0.85
0	1	1	1	0	1.05	0.85
0	1	1	1	1	1.00	0.84
1	0	0	0	0	0.975	0.84
1	0	0	0	1	0.950	0.83
1	0	0	1	0	0.925	0.83
1	0	0	1	1	0.900	0.82
1	0	1	0	0	0.875	0.82
1	0	1	0	1	0.850	0.82
1	0	1	1	0	0.825	0.81
1	0	1	1	1	0.800	0.81
1	1	0	0	0	0.775	0.80
1	1	0	0	1	0.750	0.80
1	1	0	1	0	0.725	0.79
1	1	0	1	1	0.700	0.78
1	1	1	0	0	0.675	0.78
1	1	1	0	1	0.650	0.77
1	1	1	1	0	0.625	0.76
1	1	1	1	1	0.600	0.76

# Notebook CPU Step-Down Controller for Intel Mobile Voltage Positioning (IMVP-II)

On the rising edge of ZMODE, during power-up with ZMODE high or on the falling edge of SUS when ZMODE is high, the impedances at D0–D4 are sampled by the impedance decoder to see if a large resistance is in series with the pin. This is called Impedance mode. If the voltage level on the pin is a logic low, an internal switch connects the pin to an internal 26kΩ pullup for about 4μs to see if the pin voltage can be forced high (Figure 10). If the pin voltage can be pulled to a logic high, the impedance is considered high and so is the Impedance mode logic state. Similarly, if the voltage level on the pin is a logic high, an internal switch connects the pin to an internal 8kΩ pulldown to see if the pin voltage can be forced low. If so, the pin is high impedance and its Impedance mode logic state is high. In either sampling condition, if the pin's logic level does not change, the pin is determined to be low impedance and the Impedance mode logic state is low.

A high pin impedance (and logic high) is 100kΩ or greater, and a low impedance (and logic low) is 1kΩ or less. The *Electrical Characteristics* table guaranteed levels for these impedances are 95kΩ and 1.05kΩ to allow the use of standard 100kΩ and 1kΩ resistors with 5% tolerance.

### Using the ZMODE Mux

There are many ways to use the versatile ZMODE mux. The preferred method will depend on when and how the VID DAC codes for the various states are determined. If the output voltage codes are fixed at PC board design time, program both codes with a simple combination of pin-strap connections and series resistors (Figure 11). If the output voltage codes are chosen during PC board assembly, both codes can be independently programmed with resistors (Figure 12). This

**Table 4. Suspend Mode DAC Codes**

S1	S0	OUTPUT VOLTAGE (V)
GND	GND	0.975
GND	REF	0.950
GND	OPEN	0.925
GND	V <sub>CC</sub>	0.900
REF	GND	0.875
REF	REF	0.850
REF	OPEN	0.825
REF	V <sub>CC</sub>	0.800
OPEN	GND	0.775
OPEN	REF	0.750
OPEN	OPEN	0.725
OPEN	V <sub>CC</sub>	0.700
V <sub>CC</sub>	GND	0.675
V <sub>CC</sub>	REF	0.650
V <sub>CC</sub>	OPEN	0.625
V <sub>CC</sub>	V <sub>CC</sub>	0.600

matrix of 10 resistor-footprints can be programmed to all possible Logic mode and Impedance mode code combinations with only 5 resistors.

Often the CPU pins provide one set of codes that are typically used with pullup resistors to provide the Logic mode VID code, and resistors in series with D0–D4 set the Impedance mode code. Since some of the CPU's VID pins may float, the open-circuit pins can present a problem for the ZMODE mux's Impedance mode. For the Impedance mode to work, any pins intended to be

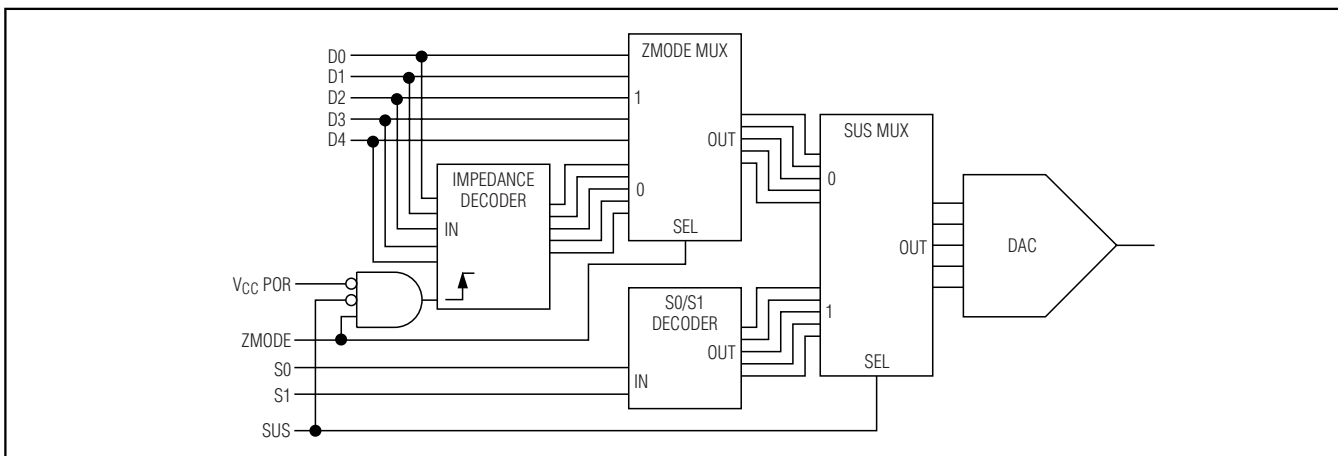

Figure 9. Internal Multiplexers Functional Diagram

# Notebook CPU Step-Down Controller for Intel Mobile Voltage Positioning (IMVP-II)

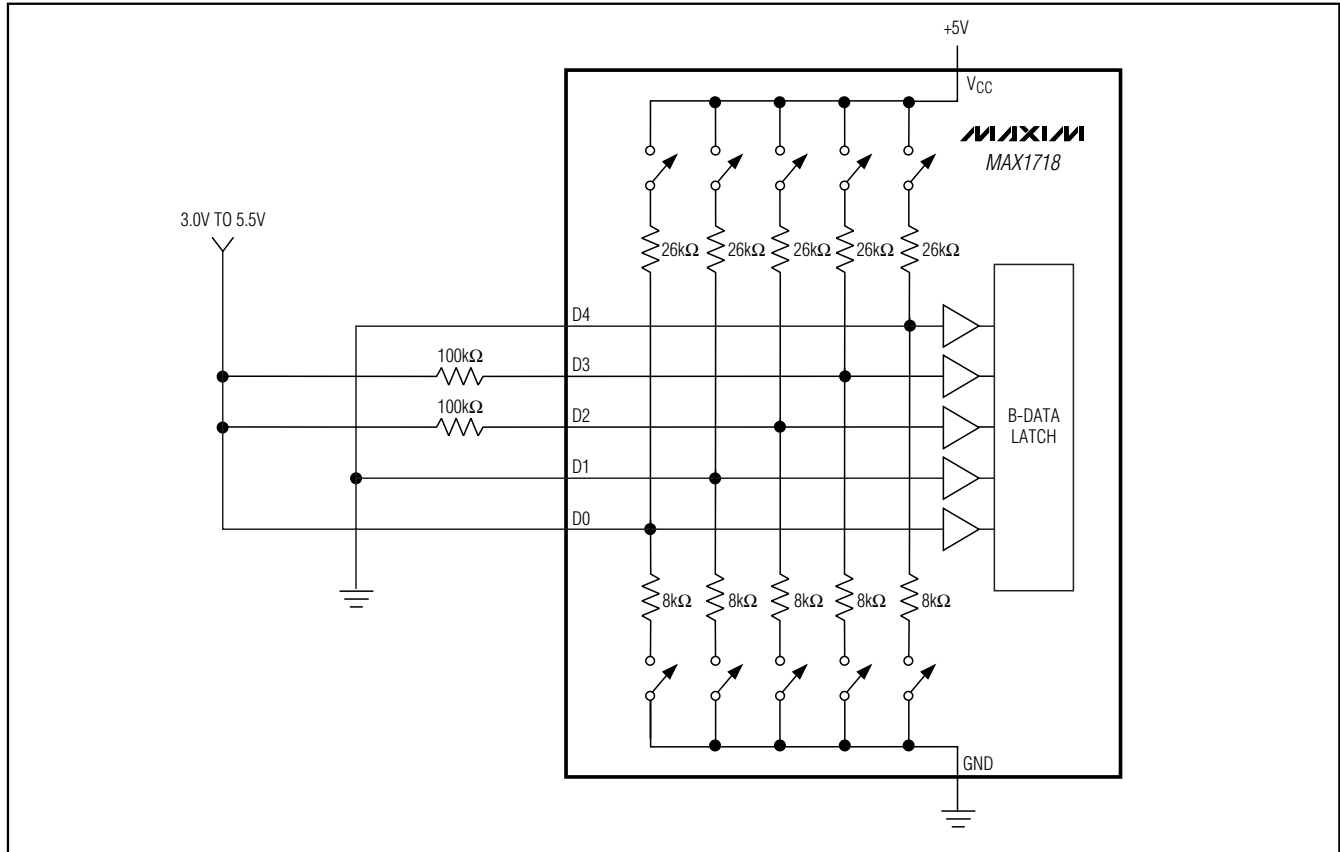

Figure 10. Internal Mux Impedance-Mode Data Test and Latch

low during Impedance mode must appear to be low impedance, at least for the 4μs sampling interval.

This can be achieved in several ways, including the following two (Figure 13). By using low-impedance pullup resistors with the CPU's VID pins, each pin provides the low impedance needed for the mux to correctly interpret the Impedance mode setting. Unfortunately, the low resistances cause several mA quiescent currents for each of the CPU's grounded VID pins. This quiescent current can be avoided by taking advantage of the fact that D0–D4 need only appear low impedance briefly, not necessarily on a continuous DC basis. High-impedance pullups can be used if they are bypassed with a large enough capacitance to make them appear low impedance for the 4μs sampling interval. As noted in Figure 13, 4.7nF capacitors allow the inputs to appear low impedance even though they are pulled up with large-value resistors. Each sampling depletes some charge from the 4.7nF capacitors. A minimum

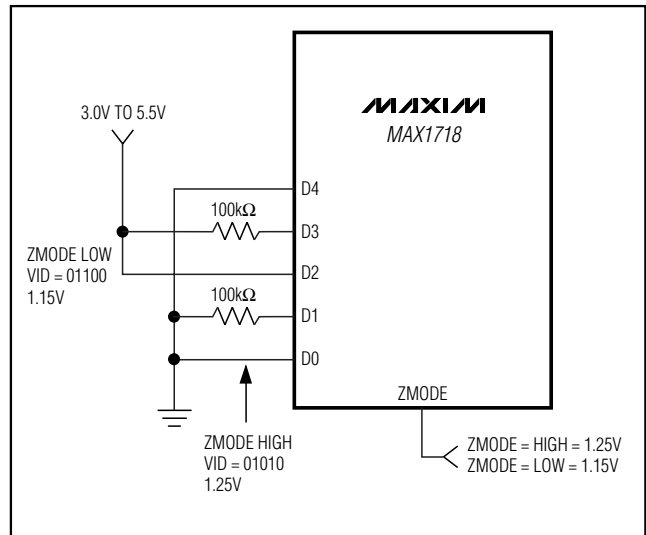

Figure 11. Using the Internal Mux with Hard-Wired Logic-Mode and Impedance-Mode DAC Codes

# Notebook CPU Step-Down Controller for Intel Mobile Voltage Positioning (IMVP-II)

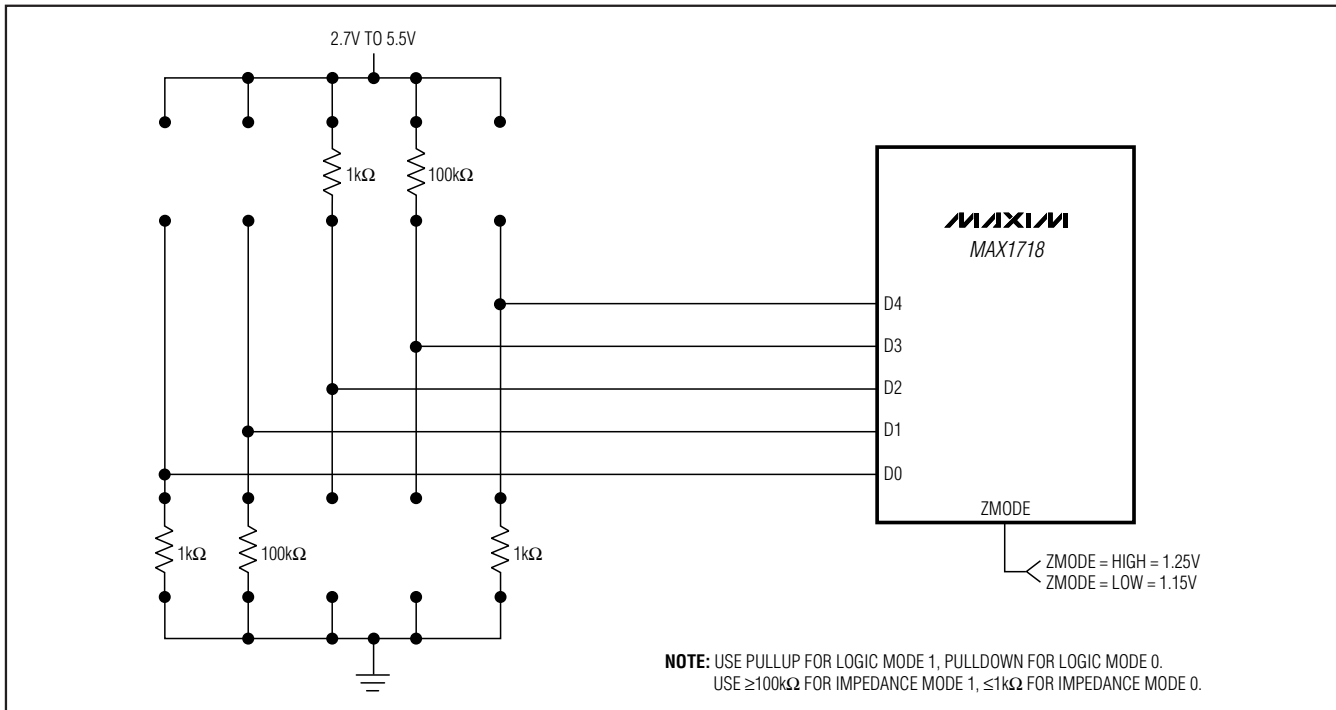

Figure 12. Using the Internal Mux with Both VID Codes Resistor Programmed

interval of  $2 \times R_{PULLUP} \times 4.7nF$  is recommended between ZMODE samples.

In some cases, it is desirable to determine the Impedance mode code during system boot so that several processor types can be used without hardware modifications. Figure 14 shows one way to implement this function. The desired code is determined by the system BIOS and programmed into one register of the MAX1609 using the SMBus™ serial interface. The MAX1609's other register is left in its power-up state (all outputs high impedance). When  $\overline{SMBSUS}$  is low, the outputs are high impedance and do not affect the Logic-mode VID code setting. When  $\overline{SMBSUS}$  is high, the programmed register is selected, and the MAX1609 forces a low impedance on the appropriate VID input pins. The ZMODE signal is delayed relative to the  $\overline{SMBSUS}$  pin because the VID pins that are pulled low by the MAX1609 take significant time to rise when they are released. One additional benefit of using the MAX1609 for this application is that the application uses only five of the MAX1609's high-voltage, open-drain outputs. The other three outputs can be used for other purposes.

Table 5. DAC Mux Operation

ZMODE	SUS	OUTPUT VOLTAGE DETERMINED BY:
GND	GND	Logic Level of D0–D4
V <sub>CC</sub>	GND	Impedance of D0–D4
X	V <sub>CC</sub>	Logic Levels of S0, S1

### Output Voltage Transition Timing

The MAX1718 is designed to perform output voltage transitions in a controlled manner, automatically minimizing input surge currents. This feature allows the circuit designer to achieve nearly ideal transitions, guaranteeing just-in-time arrival at the new output voltage level with the lowest possible peak currents for a given output capacitance. This makes the IC ideal for IMVP-II CPUs.

IMVP-II CPUs operate at two distinct clock frequencies and require three distinct VID settings. When transitioning from one clock frequency to the other, the CPU first goes into a low-power state, then the output voltage and clock frequency are changed. The change must be accomplished in 100μs or the system may halt.

SMBus™ is a trademark of Intel Corp.

# Notebook CPU Step-Down Controller for Intel Mobile Voltage Positioning (IMVP-II)

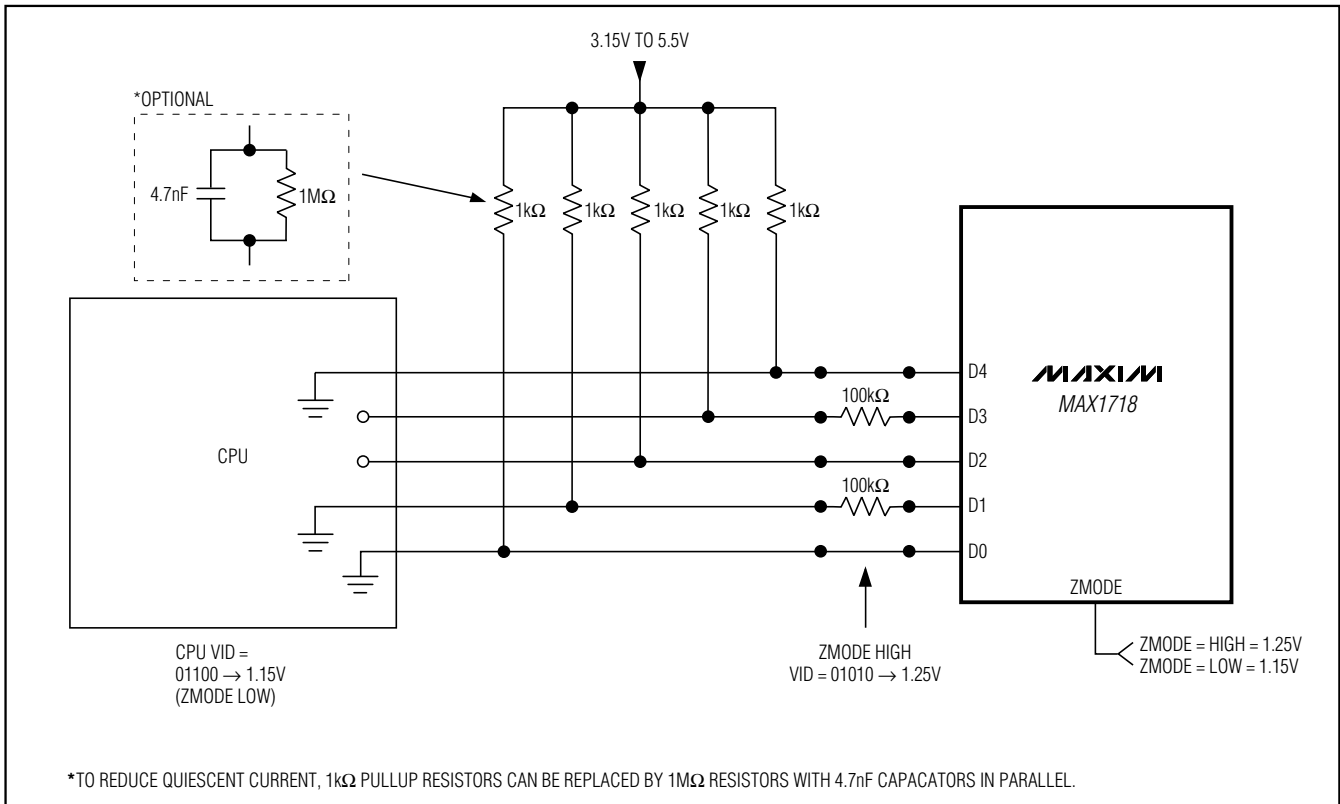

Figure 13. Using the Internal Mux with CPU Driving the Logic-Mode VID Code

At the beginning of an output voltage transition, the MAX1718 blanks the VGATE output, preventing it from going low. VGATE remains blanked during the transition and is re-enabled when the slew-rate controller has set the internal DAC to the final value and one additional slew-rate clock period has passed. The slew-rate clock frequency (set by resistor  $R_{TIME}$ ) must be set fast enough to ensure that the longest required transition is completed within the allowed 100 $\mu$ s.

The output voltage transition is performed in 25mV steps, preceded by a delay and followed by one additional clock period. The total time for a transition depends on  $R_{TIME}$ , the voltage difference, and the accuracy of the MAX1718's slew-rate clock, and is not dependent on the total output capacitance. The greater the output capacitance, the higher the surge current required for the transition. The MAX1718 will automatically control the current to the minimum level required to complete the transition in the calculated time, as long as the surge current is less than the current limit set by ILIM. The transition time is given by:

$$\leq \left[ \frac{1}{f_{SLEW}} \times \frac{V_{OLD} - V_{NEW}}{25mV} \right] + T_{DELAY}$$

where  $f_{SLEW} = 150kHz \times 120k\Omega / R_{TIME}$ ,  $V_{OLD}$  is the original DAC setting,  $V_{NEW}$  is the new DAC setting, and  $T_{DELAY}$  ranges from zero to a maximum of  $2/f_{SLEW}$ . See Time Frequency Accuracy in the *Electrical Characteristics* table for  $f_{SLEW}$  accuracy.

The practical range of  $R_{TIME}$  is 47k $\Omega$  to 470k $\Omega$ , corresponding to 2.6 $\mu$ s to 26 $\mu$ s per 25mV step. Although the DAC takes discrete 25mV steps, the output filter makes the transitions relatively smooth. The average inductor current required to make an output voltage transition is:

$$I_L \cong C_{OUT} \times 25mV \times f_{SLEW}$$

### Output Overvoltage Protection

The overvoltage protection (OVP) circuit is designed to protect the CPU against a shorted high-side MOSFET by drawing high current and blowing the battery fuse. The output voltage is continuously monitored for over-

# Notebook CPU Step-Down Controller for Intel Mobile Voltage Positioning (IMVP-II)

MAX1718

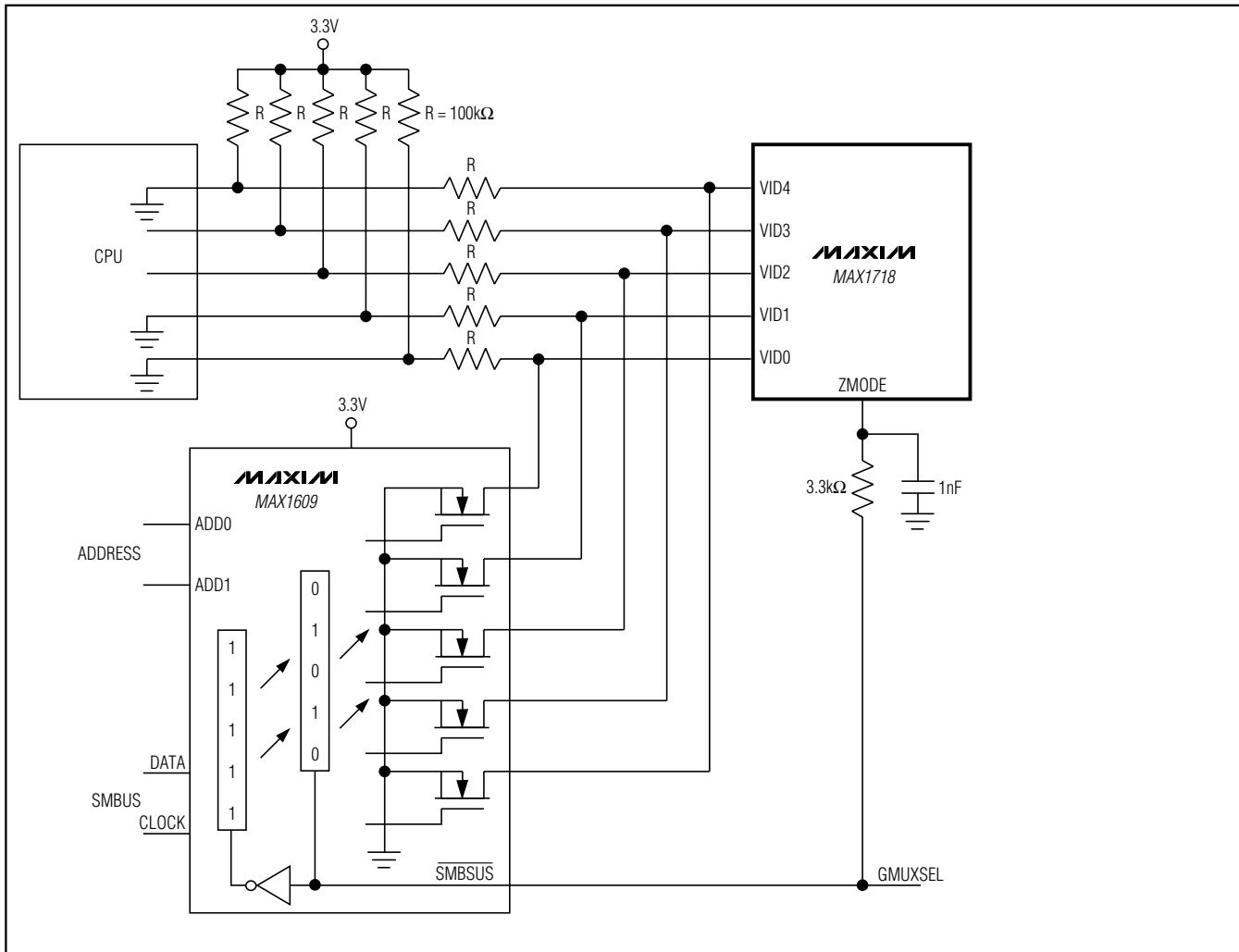

Figure 14. Using the ZMODE Multiplexer

voltage. If the output is more than 2V, OVP is triggered and the circuit shuts down. The DL low-side gate-driver output is then latched high until SKP/ $\overline{\text{SDN}}$  is toggled or  $V_{CC}$  power is cycled below 1V. This action turns on the synchronous-rectifier MOSFET with 100% duty and, in turn, rapidly discharges the output filter capacitor and forces the output to ground. If the condition that caused the overvoltage (such as a shorted high-side MOSFET) persists, the battery fuse will blow. DL is also kept high continuously when  $V_{CC}$  UVLO is active, as well as in shutdown mode (Table 6).

Overvoltage protection can be defeated with a logic high on  $\overline{\text{OVP}}$  or through the NO FAULT test mode (see the NO FAULT Test Mode section).

## Output Undervoltage Shutdown

The output UVP function is similar to foldback current limiting, but employs a timer rather than a variable current limit. If the MAX1718 output voltage is under 70% of the nominal value, the PWM is latched off and won't restart until  $V_{CC}$  power is cycled or SKP/ $\overline{\text{SDN}}$  is toggled. To allow startup, UVP is ignored during the undervoltage fault-blanking time (the first 256 cycles of the slew rate after startup).

UVP can be defeated through the NO FAULT test mode (see the NO FAULT Test Mode section).

# Notebook CPU Step-Down Controller for Intel Mobile Voltage Positioning (IMVP-II)

Table 6. Operating Mode Truth Table

SKP/SDN	DL	MODE	COMMENT
GND	High	Shutdown	Low-power shutdown state. DL is forced to $V_{DD}$ , enforcing OVP. $I_{CC} + I_{DD} = 2\mu A$ typ.
12V to 15V	Switching	No Fault	Test mode with faults disabled and fault latches cleared, including thermal shutdown. Otherwise, normal operation, with automatic PWM/PFM switchover for pulse-skipping at light loads.
Open	Switching	Run (PWM, low noise)	Low-noise operation with no automatic switchover. Fixed-frequency PWM action is forced regardless of load. Inductor current reverses at light load levels.
$V_{CC}$	Switching	Run (PFM/PWM)	Operation with automatic PWM/PFM switchover for pulse-skipping at light loads.
$V_{CC}$ or Open	High	Fault	Fault latch has been set by OVP, UVP, or thermal shutdown. Device will remain in FAULT mode until $V_{CC}$ power is cycled or SKP/SDN is forced low.

### NO FAULT Test Mode

The over/undervoltage protection features can complicate the process of debugging prototype breadboards since there are (at most) a few milliseconds in which to determine what went wrong. Therefore, a test mode is provided to disable the OVP, UVP, and thermal shutdown features, and clear the fault latch if it has been set. The PWM operates as if SKP/SDN were high (SKIP mode). The NO FAULT test mode is entered by forcing 12V to 15V on SKP/SDN.

### Design Procedure

Firmly establish the input voltage range and maximum load current before choosing a switching frequency and inductor operating point (ripple-current ratio). The primary design trade-off lies in choosing a good switching frequency and inductor operating point, and the following four factors dictate the rest of the design:

- 1) **Input Voltage Range.** The maximum value ( $V_{IN(MAX)}$ ) must accommodate the worst-case high AC adapter voltage. The minimum value ( $V_{IN(MIN)}$ ) must account for the lowest battery voltage after drops due to connectors, fuses, and battery selector switches. If there is a choice at all, lower input voltages result in better efficiency.
- 2) **Maximum Load Current.** There are two values to consider. The peak load current ( $I_{LOAD(MAX)}$ ) determines the instantaneous component stresses and filtering requirements, and thus drives output capacitor selection, inductor saturation rating, and the design of the current-limit circuit. The continuous load current ( $I_{LOAD}$ ) determines the thermal stresses and thus drives the selection of input capacitors,

MOSFETs, and other critical heat-contributing components. Modern notebook CPUs generally exhibit  $I_{LOAD} = I_{LOAD(MAX)} \times 80\%$ .

- 3) **Switching Frequency.** This choice determines the basic trade-off between size and efficiency. The optimal frequency is largely a function of maximum input voltage, due to MOSFET switching losses that are proportional to frequency and  $V_{IN}^2$ . The optimum frequency is also a moving target, due to rapid improvements in MOSFET technology that are making higher frequencies more practical.
- 4) **Inductor Operating Point.** This choice provides trade-offs between size and efficiency. Low inductor values cause large ripple currents, resulting in the smallest size, but poor efficiency and high output noise. The minimum practical inductor value is one that causes the circuit to operate at the edge of critical conduction (where the inductor current just touches zero with every cycle at maximum load). Inductor values lower than this grant no further size-reduction benefit.  
The MAX1718's pulse-skipping algorithm initiates skip mode at the critical conduction point. So, the inductor operating point also determines the load-current value at which PFM/PWM switchover occurs. The optimum point is usually found between 20% and 50% ripple current.
- 5) The inductor ripple current also impacts transient-response performance, especially at low  $V_{IN} - V_{OUT}$  differentials. Low inductor values allow the inductor current to slew faster, replenishing charge removed from the output filter capacitors by a sudden load



# Notebook CPU Step-Down Controller for Intel Mobile Voltage Positioning (IMVP-II)

step. The amount of output sag is also a function of the maximum duty factor, which can be calculated from the on-time and minimum off-time:

$$V_{SAG} = \frac{(I_{LOAD1} - I_{LOAD2})^2 \times L \left( K \frac{V_{OUT}}{V_{IN}} + t_{OFF(MIN)} \right)}{2 \times C_{OUT} \times V_{OUT} \left[ K \left( \frac{V_{IN} - V_{OUT}}{V_{IN}} \right) - t_{OFF(MIN)} \right]}$$

where  $t_{OFF(MIN)}$  is the minimum off-time (see the *Electrical Characteristics* tables) and  $K$  is from Table 2.

## Inductor Selection

The switching frequency and operating point (% ripple or LIR) determine the inductor value as follows:

$$L = \frac{V_{OUT} (V_{IN} - V_{OUT})}{V_{IN} \times f_{SW} \times LIR \times I_{LOAD(MAX)}}$$

Example:  $I_{LOAD(MAX)} = 19A$ ,  $V_{IN} = 7V$ ,  $V_{OUT} = 1.25V$ ,  $f_{SW} = 300kHz$ , 30% ripple current or  $LIR = 0.30$ .

$$L = \frac{1.25V(7V - 1.25V)}{7V \times 300kHz \times 0.30 \times 19A} = 0.60\mu H$$

Find a low-loss inductor having the lowest possible DC resistance that fits in the allotted dimensions. Ferrite cores are often the best choice, although powdered iron is inexpensive and can work well at 200kHz. The core must be large enough not to saturate at the peak inductor current ( $I_{PEAK}$ ).

$$I_{PEAK} = I_{LOAD(MAX)} + (LIR / 2) I_{LOAD(MAX)}$$

## Setting the Current Limit

The minimum current-limit threshold must be great enough to support the maximum load current when the current limit is at the minimum tolerance value. The valley of the inductor current occurs at  $I_{LOAD(MAX)}$  minus half of the ripple current; therefore:

$$I_{LIMIT(LOW)} > I_{LOAD(MAX)} - (LIR / 2) I_{LOAD(MAX)}$$

where  $I_{LIMIT(LOW)}$  equals the minimum current-limit threshold voltage divided by the  $R_{DS(ON)}$  of Q2. For the MAX1718 Figure 1 circuit, the minimum current-limit threshold with  $V_{ILIM} = 105mV$  is about 95mV. Use the worst-case maximum value for  $R_{DS(ON)}$  from the MOSFET Q2 data sheet, and add some margin for the rise in  $R_{DS(ON)}$  with temperature. A good general rule is to allow 0.5% additional resistance for each °C of temperature rise.

Examining the Figure 1 example with a Q2 maximum  $R_{DS(ON)} = 3.8m\Omega$  at  $T_J = +25^\circ C$  and  $5.7m\Omega$  at  $T_J = +125^\circ C$  reveals the following:

$$I_{LIMIT(LOW)} = 95mV / 5.7m\Omega = 16.7A$$

and the required valley current limit is:

$$I_{LIMIT(LOW)} > 19A - (0.30 / 2) 19A = 16.2A$$

Since 16.7A is greater than the required 16.2A, the circuit can deliver the full-rated 19A.

When delivering 19A of output current, the worst-case power dissipation of Q2 is 1.95W. With a thermal resistance of  $60^\circ C/W$  and each MOSFET dissipating 0.98W, the temperature rise of the MOSFETs is  $60^\circ C/W \times 0.98W = 58^\circ C$ , and the maximum ambient temperature is  $+125^\circ C - 58^\circ C = +67^\circ C$ . To operate at a higher ambient temperature, choose lower  $R_{DS(ON)}$  MOSFETs or reduce the thermal resistance. Raising the current-limit threshold allows for operation with a higher MOSFET junction temperature.

Connect  $I_{LIM}$  to  $V_{CC}$  for a default 100mV current-limit threshold. For an adjustable threshold, connect a resistor divider from REF to GND, with  $I_{LIM}$  connected to the center tap. The external adjustment range of 0.5V to 3.0V corresponds to a current-limit threshold of 50mV to 300mV. When adjusting the current limit, use 1% tolerance resistors and a  $10\mu A$  divider current to prevent a significant increase of errors in the current-limit tolerance.

## Output Capacitor Selection

The output filter capacitor must have low enough effective series resistance (ESR) to meet output ripple and load-transient requirements, yet have high enough ESR to satisfy stability requirements. Also, the capacitance value must be high enough to absorb the inductor energy going from a full-load to no-load condition without tripping the OVP circuit.

In CPU  $V_{CORE}$  converters and other applications where the output is subject to violent load transients, the output capacitor's size typically depends on how much ESR is needed to prevent the output from dipping too low under a load transient. Ignoring the sag due to finite capacitance:

$$RESR \leq V_{STEP} / I_{LOAD(MAX)}$$

The actual microfarad capacitance value required often relates to the physical size needed to achieve low ESR, as well as to the chemistry of the capacitor technology. Thus, the capacitor is usually selected by ESR and volt-

# Notebook CPU Step-Down Controller for Intel Mobile Voltage Positioning (IMVP-II)

age rating rather than by capacitance value (this is true of tantalums, OS-CONs, and other electrolytics).

When using low-capacity filter capacitors such as ceramic or polymer types, capacitor size is usually determined by the capacity needed to prevent  $V_{SAG}$  and  $V_{SOAR}$  from causing problems during load transients. Generally, once enough capacitance is added to meet the overshoot requirement, undershoot at the rising load edge is no longer a problem (see the  $V_{SAG}$  equation in the *Design Procedure* section). The amount of overshoot due to stored inductor energy can be calculated as:

$$V_{SOAR} \approx \frac{L \times I_{PEAK}^2}{2 \times C \times V_{OUT}}$$

where  $I_{PEAK}$  is the peak inductor current.

## Output Capacitor Stability Considerations

Stability is determined by the value of the ESR zero relative to the switching frequency. The voltage-positioned circuit in this data sheet has the ESR zero frequency lowered due to the external resistor in series with the output capacitor ESR, guaranteeing stability. For a voltage-positioned circuit, the minimum ESR requirement of the output capacitor is reduced by the voltage-positioning resistor value.

The boundary condition of instability is given by the following equation:

$$(R_{ESR} + R_{DROOP}) \times C_{OUT} \geq 1 / (2 \times f_{SW})$$

where  $R_{DROOP}$  is the effective value of the voltage-positioning resistor (Figure 1, R8). For good phase margin, it is recommended to increase the equivalent RC time constant by a factor of two. The standard application circuit (Figure 1) operating at 300kHz with  $C_{OUT} = 1320\mu F$ ,  $R_{ESR} = 2.5m\Omega$ , and  $R_{DROOP} = 5m\Omega$  easily meets this requirement. In some applications, the  $C_{OUT}$  and  $R_{DROOP}$  values are sufficient to guarantee stability even if  $R_{ESR} = 0$ .

The easiest method for checking stability is to apply a very fast zero-to-max load transient and carefully observe the output voltage ripple envelope for overshoot and ringing. Don't allow more than one cycle of ringing after the initial step-response under/overshoot.

## Input Capacitor Selection

The input capacitor must meet the ripple current requirement ( $I_{RMS}$ ) imposed by the switching currents defined by the following equation:

$$I_{RMS} = I_{LOAD} \sqrt{\frac{V_{OUT}(V_{IN} - V_{OUT})}{V_{IN}}}$$

For most applications, nontantalum chemistries (ceramic or OS-CON) are preferred due to their resistance to inrush surge currents typical of systems with a switch or a connector in series with the battery. If the MAX1718 is operated as the second stage of a two-stage power-conversion system, tantalum input capacitors are acceptable. In either configuration, choose an input capacitor that exhibits less than +10°C temperature rise at the RMS input current for optimal circuit longevity.

## Power MOSFET Selection

Most of the following MOSFET guidelines focus on the challenge of obtaining high load-current capability (>12A) when using high-voltage (>20V) AC adapters. Low-current applications usually require less attention.

The high-side MOSFET must be able to dissipate the resistive losses plus the switching losses at both  $V_{IN(MIN)}$  and  $V_{IN(MAX)}$ . Calculate both of these sums. Ideally, the losses at  $V_{IN(MIN)}$  should be roughly equal to the losses at  $V_{IN(MAX)}$ , with lower losses in between. If the losses at  $V_{IN(MIN)}$  are significantly higher than the losses at  $V_{IN(MAX)}$ , consider increasing the size of Q1. Conversely, if the losses at  $V_{IN(MAX)}$  are significantly higher than the losses at  $V_{IN(MIN)}$ , consider reducing the size of Q1. If  $V_{IN}$  does not vary over a wide range, the minimum power dissipation occurs where the resistive losses equal the switching losses.

Choose a low-side MOSFET (Q2) that has the lowest possible  $R_{DS(ON)}$ , comes in a moderate-sized package (i.e., two or more SO-8s, DPAKs or D<sup>2</sup>PAKs), and is reasonably priced. Ensure that the MAX1718 DL gate driver can drive Q2; in other words, check that the  $dv/dt$  caused by Q1 turning on does not pull up the Q2 gate due to drain-to-gate capacitance, causing cross-conduction problems. Switching losses aren't an issue for the low-side MOSFET since it's a zero-voltage switched device when used in the buck topology.

## MOSFET Power Dissipation

The high-side MOSFET power dissipation due to resistance is:

$$PD(Q1 \text{ Resistive}) = \frac{V_{OUT}}{V_{IN}} \times I_{LOAD}^2 \times R_{DS(ON)}$$

Generally, a small high-side MOSFET is desired to reduce switching losses at high input voltages. However, the  $R_{DS(ON)}$  required to stay within package

# Notebook CPU Step-Down Controller for Intel Mobile Voltage Positioning (IMVP-II)

power-dissipation limits often limits how small the MOSFET can be.

Switching losses in the high-side MOSFET can become an insidious heat problem when maximum AC adapter voltages are applied, due to the squared term in the  $CV^2f_{SW}$  switching-loss equation. If the high-side MOSFET you've chosen for adequate  $R_{DS(ON)}$  at low battery voltages becomes extraordinarily hot when subjected to  $V_{IN(MAX)}$ , reconsider your choice of MOSFET.

Calculating the power dissipation in Q1 due to switching losses is difficult since it must allow for difficult quantifying factors that influence the turn-on and turn-off times. These factors include the internal gate resistance, gate charge, threshold voltage, source inductance, and PC board layout characteristics. The following switching-loss calculation provides only a very rough estimate and is no substitute for breadboard evaluation and temperature measurements:

$$PD(Q1 \text{ Switching}) = \frac{C_{RSS} \times V_{IN(MAX)}^2 \times f_{SW} \times I_{LOAD}}{I_{GATE}}$$

where  $C_{RSS}$  is the reverse transfer capacitance of Q1 and  $I_{GATE}$  is the peak gate-drive source/sink current (2A typ).

For the low-side MOSFET (Q2), the worst-case power dissipation always occurs at maximum battery voltage:

$$PD(Q2) = \left(1 - \frac{V_{OUT}}{V_{IN(MAX)}}\right) I_{LOAD}^2 \times R_{DS(ON)}$$

For both Q1 and Q2, note the MOSFET's maximum junction temperature and the thermal resistance that will be realistically achieved with the device packaging and your thermal environment to avoid overheating.

The absolute worst case for MOSFET power dissipation occurs under heavy overloads that are greater than  $I_{LOAD(MAX)}$  but are not quite high enough to exceed the current limit and cause the fault latch to trip. To protect against this possibility, you can "overdesign" the circuit to tolerate:

$$I_{LOAD} = I_{LIMIT(HIGH)} + (LIR / 2) \times I_{LOAD(MAX)}$$

where  $I_{LIMIT(HIGH)}$  is the maximum valley current allowed by the current-limit circuit, including threshold tolerance and on-resistance variation. This means that the MOSFETs must be very well heatsinked. If short-circuit protection without overload protection is enough, a normal  $I_{LOAD}$  value can be used for calculating component stresses.

Choose a Schottky diode (D1) having a forward voltage low enough to prevent the Q2 MOSFET body diode from turning on during the dead time. As a general rule, a diode having a DC current rating equal to 1/3 of the load current is sufficient. This diode is optional and can be removed if efficiency isn't critical.

## Applications Information

### Voltage Positioning

Powering new mobile processors requires new techniques to reduce cost, size, and power dissipation. Voltage positioning reduces the total number of output capacitors to meet a given transient response requirement. Setting the no-load output voltage slightly higher allows a larger step down when the output current suddenly increases, and regulating at the lower output voltage under load allows a larger step up when the output current suddenly decreases. Allowing a larger step size means that the output capacitance can be reduced and the capacitor's ESR can be increased.

Adding a series output resistor positions the full-load output voltage below the actual DAC programmed voltage. Connect FB directly to the inductor side of the voltage-positioning resistor (R8, 4m $\Omega$ ). The other side of the voltage-positioning resistor should be connected directly to the output filter capacitor with a short, wide PC board trace. With a 20A full-load current, R8 causes an 80mV drop. This 80mV is a -6.4% droop.

An additional benefit of voltage positioning is reduced power consumption at high load currents. Because the output voltage is lower under load, the CPU draws less current. The result is lower power dissipation in the CPU, although some extra power is dissipated in R8. For a nominal 1.25V, 20A output, reducing the output voltage 6.4% gives an output voltage of 1.17V and an output current of 18.7A. Given these values, CPU power consumption is reduced from 25W to 21.9W. The additional power consumption of R8 is:

$$4m\Omega \times 18.7A^2 = 1.4W$$

And the overall power savings is as follows:

$$25 - (21.9 + 1.4) = 1.7W$$

In effect, 3W of CPU dissipation is saved, and the power supply dissipates some of the power savings, but both the net savings and the transfer of dissipation away from the hot CPU are beneficial.

### Reduced-Power-Dissipation Voltage Positioning

A key benefit of voltage positioning is reduced power dissipation, especially at heavy loads. In the standard

## Notebook CPU Step-Down Controller for Intel Mobile Voltage Positioning (IMVP-II)

application circuit (Figure 1) voltage positioning is accomplished using a droop resistor (R8), which can dissipate over 1W. Although the power savings in the processor is much greater than the dissipation in the resistor, 1W of dissipation is still far from ideal.

The resistor is a necessary component because accurate voltage positioning depends on an accurate current-sense element. But it is not necessary to drop the entire positioning voltage across this resistor. The circuit of Figure 15 uses an external op amp to add gain to R8's voltage signal, allowing the resistor value and power dissipation to be divided by the gain factor.

The recommended range for the gain is up to about 4, with preferred practical values around 1.5-3. There are several difficulties with high gains. If high gain is used, the sense-resistor value will be very small ( $<1\text{m}\Omega$ ). The sense signal will also be small, potentially causing noise and stability problems. Also, output voltage and positioning accuracy are essential. A smaller sense signal will reduce accuracy, as will any op amp input voltage offset, which is increased by the gain factor.

The op amp output directly drives FB. To ensure stability, the output voltage ripple and the ripple signal across R8 must be delivered with good fidelity. To preserve higher harmonics in the ripple signal, the circuit bandwidth should be about 10 times the switching frequency.

In addition to lowering power dissipation, the gain stage provides another benefit; it eases the task of providing the required positioning slope, using available discrete values for R8. A lower value resistor can be used and the gain adjusted to deliver the desired slope. Sometimes the desired slope is not well known before the final PC board is evaluated. A good practice is to adjust the final gain to deliver the correct voltage slope at the processor pins, adjusting for the actual copper losses in the supply and ground paths. This does not remove the requirement to minimize copper losses because they vary with temperature and PC board production lot. But it does provide an easy, practical way to account for their typical expected voltage drops.

Replacing the droop resistor with a lower value resistor and a gain stage does not affect the MAX1718 stability criteria. The IC cannot distinguish one from the other, as long as the required signal integrity is maintained. R8's effective value can be used to guarantee stability with extremely low-ESR (ceramic) output capacitors (see the *Output Capacitor Stability Considerations* section). The effective value is the resistor value that would

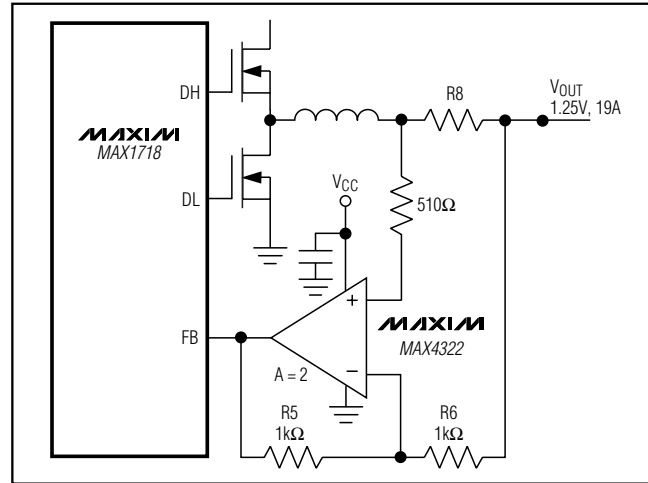

Figure 15. Lowering Voltage-Positioning Power Dissipation

result in the same signal delivered to the MAX1718's FB pin, or R8 times the op-amp circuit's gain.

Although the op amp should be placed near R8 to minimize input noise pickup, power it from the MAX1718's quiet VCC supply and analog ground to prevent other noise problems.

### High-Accuracy Current Limit

The MAX1718's integrated current limit uses the synchronous rectifier's  $R_{DS(ON)}$  for its current-sense element. This dependence on a poorly specified resistance with high temperature variation means that the integrated current limit is useful mainly in high-overload and short-circuit conditions. A moderate overload may be tolerated indefinitely. This arrangement is tolerable because there are other ways to detect overload conditions and take appropriate action. For example, if the CPU draws excessive current (but not enough to activate the current limit) the CPU will heat up, and eventually the system will take notice and shut down.

While this approach is usually acceptable, it is far from optimal. An inaccurate current limit causes component specification difficulties. What values should be used for inductor saturation ratings, MOSFET peak current requirements, and power dissipation requirements? An accurate current limit makes these issues more manageable. The circuit of Figure 16 uses an external op amp, together with the voltage-positioning resistor (R8) to implement an accurate inductor current limit.

A voltage divider from the positive side of R8 creates a threshold several mVs below the output. When the voltage drop across R8 exceeds the threshold, current lim-

# Notebook CPU Step-Down Controller for Intel Mobile Voltage Positioning (IMVP-II)

iting occurs. The op amp causes current limiting by lowering the voltage on the ILIM pin. This lowers the current-limit threshold of the IC's internal current-limit circuit, which uses the MOSFET  $R_{DS(ON)}$  as usual. The op-amp output swing has the ability to adjust the IC's internal valley current limit from a value much higher than ever needed (given the MOSFET's  $R_{RD(ON)}$ ) to a value much lower than required to support a normal load.

The bandwidth of the ILIM pin is not high, so the speed of the op amp is not critical. Any op amp or comparator could be acceptable, as long as its input offset does not degrade current-limit accuracy excessively, has input common-mode range to ground and has Rail-to-Rail® output swing. Because the bandwidth is low, the circuit responds to the average inductor current rather than the peak or valley current, eliminating the current limit's dependence on inductor ripple current.

Similar to a foldback current limit, this circuit must be carefully designed to guarantee startup. The op amp must be incapable of setting the current limit to zero or else the power supply may be unable to start. The three-way divider from REF to ground to the op-amp output allows the op amp to vary the MAX1718's internal current-limit threshold from 21mV (severely limiting current) to 182mV (more than guaranteeing the maximum required output current). These divider resistors should be chosen with the required current and the synchronous rectifier's  $R_{RD(ON)}$  in mind to ensure that the op-amp adjustment range is high enough to guarantee the required output current. The voltage at the ILIM pin is given by:

$$V_{ILIM} = \frac{(R_{12} \times R_{13} \times V_{REF}) + (R_{13} \times R_{14} \times V_{COMP})}{(R_{12} \times R_{14}) + (R_{12} \times R_{13}) + (R_{13} \times R_{14})}$$

where  $V_{COMP}$  is the voltage at the output of the comparator. The minimum  $V_{ILIM}$  is calculated when  $V_{COMP}$  is at the  $V_{OL}$  of the comparator. The maximum  $V_{ILIM}$  is calculated when  $V_{COMP} = V_{OH}$  at the minimum  $V_{CC}$ . The valley current-limit threshold is set at 10% of the voltage  $V_{ILIM}$ . C13 should be picked to give approximately 10µs time constant at the ILIM input.

The actual threshold at which the op amp begins to limit current is determined by R8 and the R10/R11 divider values and is very easy to set. Ideally,  $I_{OUT(MAX)} \times R8 = V_{FB} \times R10 / (R10 + R11)$ . In practice, some margin must be added for resistor accuracy, op-amp input offset, and general safety. With the op amp shown and ±1% resistors, 10% margin is adequate.

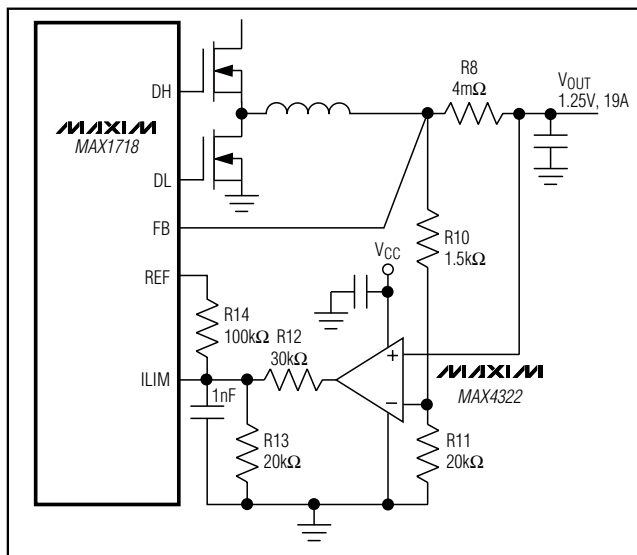

Figure 16. Improving Current-Limit Accuracy

An additional benefit of this circuit is that the current-limit value is proportional to the output voltage setting ( $V_{FB}$ ). When the output voltage setting is lowered, the current limit automatically adjusts to a more appropriate level, providing additional protection without compromising performance since the reduction of the required load current is greater than that of the output voltage setting. In some cases, the current required to slew the output capacitor may be large enough to require the current limit to be increased beyond what is necessary to support the load.

This circuit is completely compatible with the circuit of Figure 15. If the two circuits are used together, the MAX4326 dual op amp in a µMAX package can replace the two single devices, saving space and cost. If both are used, the reduced R8 value makes the op-amp input offset more significant. Additional margin might be needed, depending on the magnitude of R8's reduction.

Although the op amp should be placed near R8 to minimize input noise pickup, power it from the MAX1718's quiet  $V_{CC}$  supply and analog ground to prevent other noise problems.

### Using Skip Mode During Suspend (SKP/SDN = VCC)

Typically, for the MAX1718's intended application, the minimum output currents are too high to benefit from pulse-skipping operation in all active CPU modes. Furthermore, Skip mode can be a hindrance to properly executing downward output voltage transitions (see the

Rail-to-Rail is a registered trademark of Nippon Motorola, Ltd.

# Notebook CPU Step-Down Controller for Intel Mobile Voltage Positioning (IMVP-II)

Forced-PWM Mode section). However, processor suspend currents can be low enough that Skip mode operation provides a real benefit.

In the circuit of Figure 17, SKP/SDN remains biased at 2V in every state except Suspend and Shutdown. In addition, upon entering Suspend (SUS going high) the pin remains at 2V for about 200μs before it eventually goes high. This causes the MAX1718 to remain in PWM mode long enough to correctly complete the negative output voltage transition to the Suspend state voltage. When SKP/SDN goes high, the MAX1718 enters its low-quiescent-current Skip mode.

## Dropout Performance

The output voltage adjust range for continuous-conduction operation is restricted by the nonadjustable 500ns (max) minimum off-time one-shot (375ns max at 1000kHz). For best dropout performance, use the slower (200kHz) on-time settings. When working with low input voltages, the duty-factor limit must be calculated using worst-case values for on- and off-times. Manufacturing tolerances and internal propagation delays introduce an error to the TON K-factor. This error is greater at higher frequencies (Table 2). Also, keep in mind that transient response performance of buck regulators operated close to dropout is poor, and bulk output capacitance must often be added (see the VSAG equation in the *Design Procedure* section).

The absolute point of dropout is when the inductor current ramps down during the minimum off-time ( $\Delta I_{DOWN}$ ) as much as it ramps up during the on-time ( $\Delta I_{UP}$ ). The ratio  $h = \Delta I_{UP}/\Delta I_{DOWN}$  is an indicator of ability to slew the inductor current higher in response to increased load, and must always be greater than 1. As  $h$  approaches 1, the absolute minimum dropout point, the inductor current will be less able to increase during each switching cycle and VSAG will greatly increase unless additional output capacitance is used.

A reasonable minimum value for  $h$  is 1.5, but this may be adjusted up or down to allow tradeoffs between VSAG, output capacitance, and minimum operating voltage. For a given value of  $h$ , the minimum operating voltage can be calculated as:

$$V_{IN(MIN)} = \frac{(V_{OUT} + V_{DROPP1})}{1 - \left( \frac{T_{OFF(MIN)} \times h}{K} \right)} + V_{DROPP2} - V_{DROPP1}$$

where  $V_{DROPP1}$  and  $V_{DROPP2}$  are the parasitic voltage drops in the discharge and charge paths, respectively (see the *On-Time One-Shot (TON)* section),  $T_{OFF(MIN)}$  is from the *Electrical Characteristics* tables, and  $K$  is taken

from Table 2. The absolute minimum input voltage is calculated with  $h = 1$ .

If the calculated  $V_{IN(MIN)}$  is greater than the required minimum input voltage, then operating frequency must be reduced or output capacitance added to obtain an acceptable VSAG. If operation near dropout is anticipated, calculate VSAG to be sure of adequate transient response.

## Dropout Design Example:

$$V_{OUT} = 1.6V$$

$$f_{sw} = 550kHz$$

$$K = 1.8\mu s, \text{ worst-case } K = 1.58\mu s$$

$$T_{OFF(MIN)} = 500ns$$

$$V_{DROPP1} = V_{DROPP2} = 100mV$$

$$h = 1.5$$

$$V_{IN(MIN)} = (1.6V + 0.1V) / (1 - 0.5\mu s \times 1.5 / 1.58\mu s) + 0.1V - 0.1V = 3.2V$$

Calculating again with  $h = 1$  gives the absolute limit of dropout:

$$V_{IN(MIN)} = (1.6V + 0.1V) / (1 - 1.0 \times 0.5\mu s / 1.58\mu s) - 0.1V + 0.1V = 2.5V$$

Therefore,  $V_{IN}$  must be greater than 2.5V, even with very large output capacitance, and a practical input voltage with reasonable output capacitance would be 3.2V.

## Adjusting V<sub>OUT</sub> with a Resistor-Divider

The output voltage can be adjusted with a resistor-divider rather than the DAC if desired (Figure 18). The drawback is that the on-time doesn't automatically receive correct compensation for changing output voltage levels. This can result in variable switching frequency as the resistor ratio is changed, and/or excessive switching frequency. The equation for adjusting the output voltage is:

$$V_{OUT} = V_{FB} \left( 1 + \frac{R_1}{R_2} \right)$$

where  $V_{FB}$  is the currently selected DAC value. In resistor-adjusted circuits, the DAC code should be set as close as possible to the actual output voltage in order to minimize the shift in switching frequency.

## One-Stage (Battery Input) vs. Two-Stage (5V Input) Applications

The MAX1718 can be used with a direct battery connection (one stage) or can obtain power from a regulated 5V supply (two stage). Each approach has advantages,

# Notebook CPU Step-Down Controller for Intel Mobile Voltage Positioning (IMVP-II)

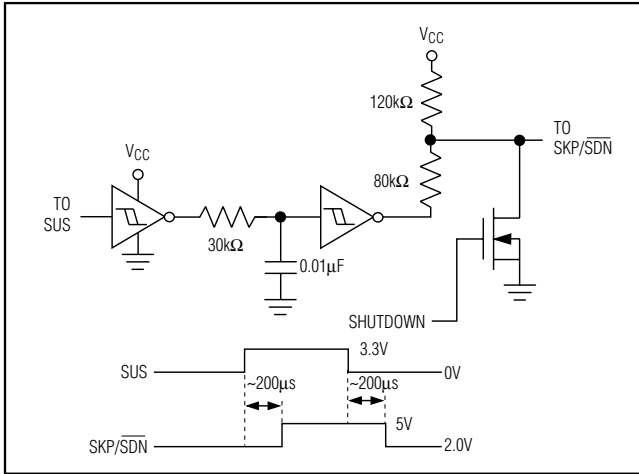

Figure 17. Using Skip Mode During Suspend ( $SKP/\overline{SDN} = V_{CC}$ )

and careful consideration should go into the selection of the final design.

The one-stage approach offers smaller total inductor size and fewer capacitors overall due to the reduced demands on the 5V supply. The transient response of the single stage is better due to the ability to ramp up the inductor current faster. The total efficiency of a single stage is better than the two-stage approach.

The two-stage approach allows flexible placement due to smaller circuit size and reduced local power dissipation. The power supply can be placed closer to the CPU for better regulation and lower  $I^2R$  losses from PC board traces. Although the two-stage design has worse transient response than the single stage, this can be offset by the use of a voltage-positioned converter.

## Ceramic Output Capacitor Applications

Ceramic capacitors have advantages and disadvantages. They have ultra-low ESR and are noncombustible, relatively small, and nonpolarized. They are also expensive and brittle, and their ultra-low ESR characteristic can result in excessively high ESR zero frequencies (affecting stability in nonvoltage-positioned circuits). In addition, their relatively low capacitance value can cause output overshoot when going abruptly from full-load to no-load conditions, unless the inductor value can be made small (high switching frequency), or there are some bulk tantalum or electrolytic capacitors in parallel to absorb the stored energy in the inductor. In some cases, there may be no room for electrolytics, creating a need for a DC-DC design that uses nothing but ceramics.

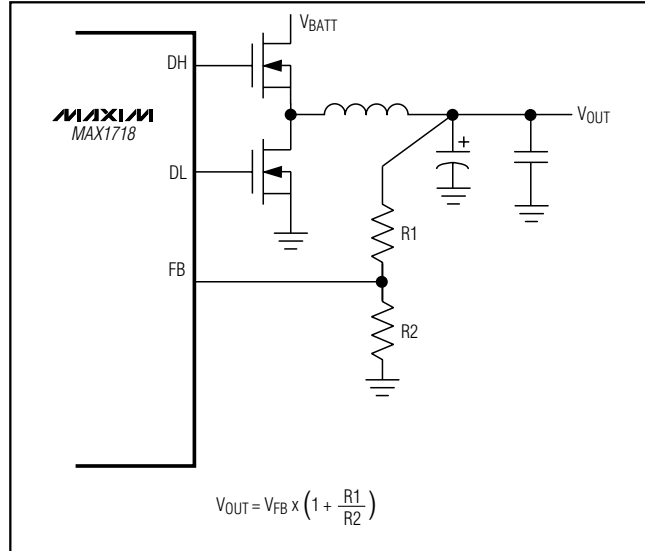

Figure 18. Adjusting  $V_{OUT}$  with a Resistor-Divider

The MAX1718 can take full advantage of the small size and low ESR of ceramic output capacitors in a voltage-positioned circuit. The addition of the positioning resistor increases the ripple at FB, lowering the effective ESR zero frequency of the ceramic output capacitor.

Output overshoot ( $V_{SOAR}$ ) determines the minimum output capacitance requirement (see the *Output Capacitor Selection* section). Often the switching frequency is increased to 550kHz or 1000kHz, and the inductor value is reduced to minimize the energy transferred from inductor to capacitor during load-step recovery. The efficiency penalty for operating at 550kHz is about 2% to 3% and about 5% at 1000kHz when compared to the 300kHz voltage-positioned circuit, primarily due to the high-side MOSFET switching losses.

## PC Board Layout Guidelines

Careful PC board layout is critical to achieve low switching losses and clean, stable operation. The switching power stage requires particular attention (Figure 19). If possible, mount all of the power components on the top side of the board with their ground terminals flush against one another. Follow these guidelines for good PC board layout:

- 1) Keep the high-current paths short, especially at the ground terminals. This is essential for stable, jitter-free operation.
- 2) All analog grounding is done to a separate solid copper plane, which connects to the MAX1718 at the GND pin. This includes the  $V_{CC}$ , REF, and CC

# Notebook CPU Step-Down Controller for Intel Mobile Voltage Positioning (IMVP-II)

capacitors, the TIME resistor, as well as any other resistor-dividers.

- 3) Keep the power traces and load connections short. This is essential for high efficiency. The use of thick copper PC boards (2oz vs. 1oz) can enhance full-load efficiency by 1% or more. Correctly routing PC board traces is a difficult task that must be approached in terms of fractions of centimeters, where a single milliohm of excess trace resistance causes a measurable efficiency penalty.
- 4) LX and GND connections to Q2 for current limiting must be made using Kelvin sense connections to guarantee the current-limit accuracy. With SO-8 MOSFETs, this is best done by routing power to the MOSFETs from outside using the top copper layer, while connecting GND and LX inside (underneath) the SO-8 package.
- 5) When trade-offs in trace lengths must be made, it's preferable to allow the inductor charging path to be made longer than the discharge path. For example, it's better to allow some extra distance between the input capacitors and the high-side MOSFET than to allow distance between the inductor and the low-side MOSFET or between the inductor and the output filter capacitor.
- 6) Ensure the FB connection to the output is short and direct. In voltage-positioned circuits, the FB connection is at the junction of the inductor and the positioning resistor.
- 7) Route high-speed switching nodes away from sensitive analog areas (CC, REF, ILIM). Make all pin-strap control input connections (SKP/ $\overline{\text{SDN}}$ , ILIM, etc.) to analog ground or VCC rather than power ground or VDD.

### Layout Procedure

- 1) Place the power components first, with ground terminals adjacent (Q2 source, CIN-, COUT-, D1 anode).

If possible, make all these connections on the top layer with wide, copper-filled areas.

- 2) Mount the controller IC adjacent to MOSFET Q2, preferably on the back side opposite Q2 in order to keep LX-GND current-sense lines and the DL drive line short and wide. The DL gate trace must be short and wide, measuring 10 to 20 squares (50mils to 100mils wide if the MOSFET is 1 inch from the controller IC).
- 3) Group the gate-drive components (BST diode and capacitor, VDD bypass capacitor) together near the controller IC.
- 4) Make the DC-DC controller ground connections as shown in Figure 19. This diagram can be viewed as having three separate ground planes: output ground, where all the high-power components go; the GND plane, where the GND pin and VDD bypass capacitors go; and an analog ground plane where sensitive analog components go. The analog ground plane and GND plane must meet only at a single point directly beneath the IC. These two planes are then connected to the high-power output ground with a short connection from GND to the source of the low-side MOSFET Q2 (the middle of the star ground). This point must also be very close to the output capacitor ground terminal.
- 5) Connect the output power planes (VCORE and system ground planes) directly to the output filter capacitor positive and negative terminals with multiple vias. Place the entire DC-DC converter circuit as close to the CPU as is practical.

### Chip Information

TRANSISTOR COUNT: 7190



# Notebook CPU Step-Down Controller for Intel Mobile Voltage Positioning (IMVP-II)

MAX1718

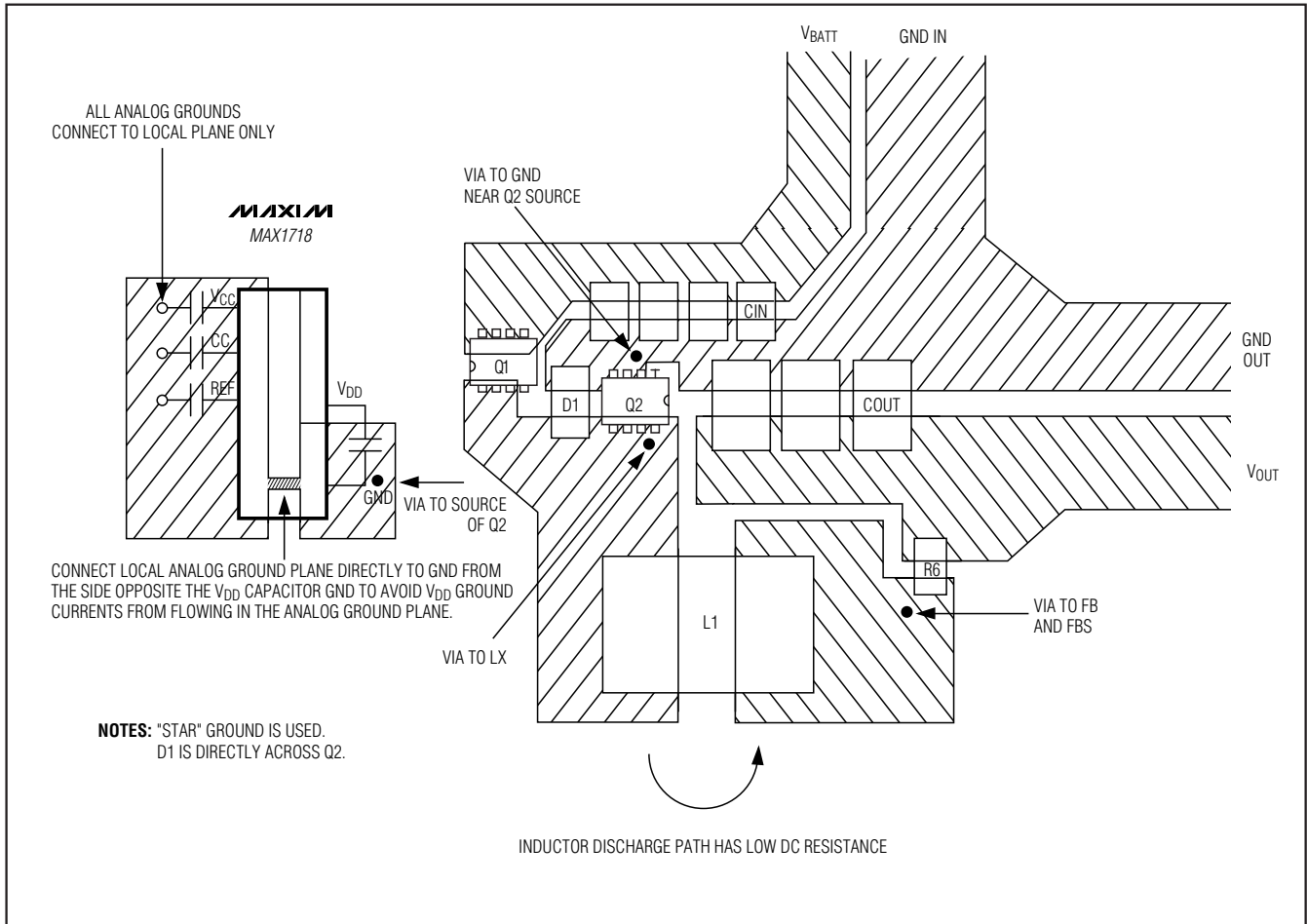
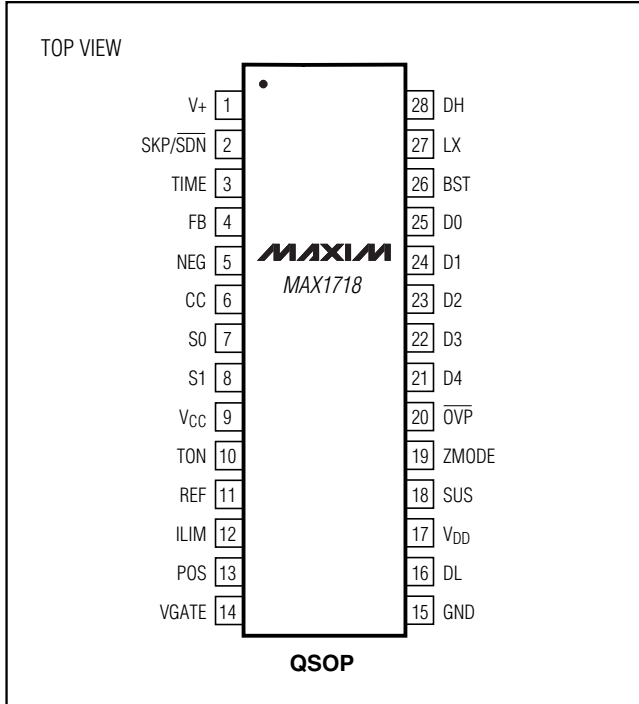

Figure 19. Power-Stage PC Board Layout Example

# Notebook CPU Step-Down Controller for Intel Mobile Voltage Positioning (IMVP-II)

## Pin Configuration



# Notebook CPU Step-Down Controller for Intel Mobile Voltage Positioning (IMVP-II)

**MAX1718**

## Package Information

(The package drawing(s) in this data sheet may not reflect the most current specifications. For the latest package outline information, go to [www.maxim-ic.com/packages](http://www.maxim-ic.com/packages).)

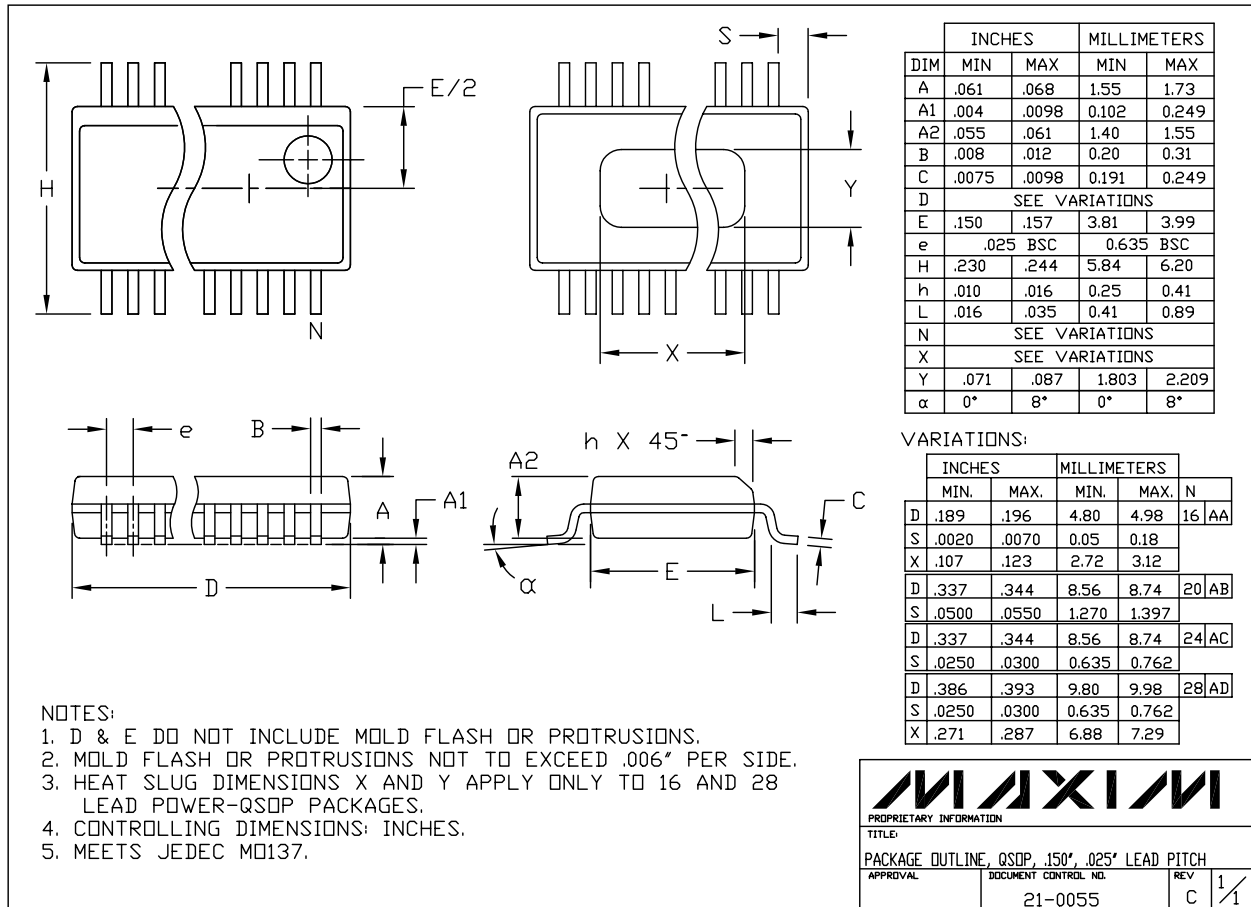

**Note:** The MAX1718 does not have a heat slug.

Maxim cannot assume responsibility for use of any circuitry other than circuitry entirely embodied in a Maxim product. No circuit patent licenses are implied. Maxim reserves the right to change the circuitry and specifications without notice at any time.

35 **Maxim Integrated Products, 120 San Gabriel Drive, Sunnyvale, CA 94086 408-737-7600**



Компания «ЭлектроПласт» предлагает заключение долгосрочных отношений при поставках импортных электронных компонентов на взаимовыгодных условиях!

Наши преимущества:

- Оперативные поставки широкого спектра электронных компонентов отечественного и импортного производства напрямую от производителей и с крупнейших мировых складов;
- Поставка более 17-ти миллионов наименований электронных компонентов;
- Поставка сложных, дефицитных, либо снятых с производства позиций;
- Оперативные сроки поставки под заказ (от 5 рабочих дней);
- Экспресс доставка в любую точку России;
- Техническая поддержка проекта, помощь в подборе аналогов, поставка прототипов;
- Система менеджмента качества сертифицирована по Международному стандарту ISO 9001;
- Лицензия ФСБ на осуществление работ с использованием сведений, составляющих государственную тайну;
- Поставка специализированных компонентов (Xilinx, Altera, Analog Devices, Intersil, Interpoint, Microsemi, Aeroflex, Peregrine, Syfer, Eurofarad, Texas Instrument, Miteq, Cobham, E2V, MA-COM, Hittite, Mini-Circuits, General Dynamics и др.);

Помимо этого, одним из направлений компании «ЭлектроПласт» является направление «Источники питания». Мы предлагаем Вам помощь Конструкторского отдела:

- Подбор оптимального решения, техническое обоснование при выборе компонента;
- Подбор аналогов;
- Консультации по применению компонента;
- Поставка образцов и прототипов;
- Техническая поддержка проекта;
- Защита от снятия компонента с производства.



#### Как с нами связаться

**Телефон:** 8 (812) 309 58 32 (многоканальный)

**Факс:** 8 (812) 320-02-42

**Электронная почта:** [org@eplast1.ru](mailto:org@eplast1.ru)

**Адрес:** 198099, г. Санкт-Петербург, ул. Калинина, дом 2, корпус 4, литера А.