

# Phantom Fin Multiband Roof Mount Antenna FHQ69273CE



Patent Pending

## PHANTOM FIN 4G/LTE, GPS, UHF & WLAN ROOF MOUNT ANTENNA

The Laird Phantom Fin multiband antenna provides an excellent solution for the public safety, transportation and after market fleet applications. The Phantom Fin requires only (1) one single hole mount/fixing which reduces vehicle damage, cost of installation and visual impact. The Phantom Fin design provides multiple antenna functions while remaining discrete. The Phantom Fin multiband antenna integrates 4G/LTE, GPS, UHF and WLAN frequency operation into one aerodynamic housing.

### FEATURES

- One (1) single hole mount/fixing which reduces vehicle damage and cost of installation.
- Attractive IP67 aerodynamic housing excellent for overt and/or discrete installations.
- Multiband 4G/LTE, GPS, UHF, and WLAN frequency operation.

### MARKETS

- Public Safety
- Transportation
- Aftermarket Fleet
- Land Mobile Radio

### SPECIFICATIONS

PARAMETER	PERFORMANCE					
Antenna Model / No. of Ports:	FHQ69273CE 4 ports					
Port ID	4G/LTE Port		WiFi Port		UHF Port	
Frequency Bands, MHz	698-960 MHz	1710-2700 MHz	2400-2500 MHz	4900-5875 MHz	430-520 MHz	
Peak Gain, Typical dBi	3.5 dBi	5.4 dBi	6.5 dBi	6.5 dBi	2.1 dBi	
Peak Gain, Maximum dBi	4.1 dBi	7.1 dBi	7.3 dBi	8.2 dBi	2.5 dBi	
Max Gain ± 30° Above Horizon, dBi	N/A	N/A	N/A	3.6 dBi	N/A	
VSWR*, Typical	< 1.8:1	< 1.4:1	< 1.3:1	< 1.3:1	< 1.7:1	
VSWR*, Max	< 2.0:1	< 2.0:1	< 2.0:1	< 2.0:1	< 2.0:1	
Port-to-Port Isolation, Maximum (Typical)	UHF-LTE	> 15 dB (15 dB)	UHF-WiFi	> 20 dB (35 dB)	LTE-WiFi	> 20 dB (22 dB)
Nominal Impedance	50 Ohms					
Polarization	Vertical Linear					
Azimuth Beam Width	Omnidirectional					
Input Power, Max	10 watt (ambient temp. of 25°C / 77°F)					
Operating Temperature	- 30°C to + 70°C ( - 22°F to + 158°F )					
Storage Temperature	- 40°C to + 85°C ( - 40°F to + 185°F )					
Dimensions HxLxW mm (inches)	98 x 70 x 160 ( 3.9"x 2.7" x 6.30")					
Weight Kg (lbs.)	Approximately 0.52 Kg (1.15 lbs.)					
Cable	LMR-100 ( 5.18 m / 17 ft.)					
Radome Material	PC/ASA (Black)					
Baseplate Material	Aluminum					
Material Compliance	RoHS Compliant					
IP Dust & Water Ingress Rating	IP67					

Americas: +1.847 839.6925  
IAS-AmericasEastSales@lairdtech.com

Europe: +44.(0).1628.858941  
IAS-EUSales@lairdtech.com

Asia: IAS-AsiaSales@lairdtech.com

www.lairdtech.com

Laird warrants to the original end user customer of its products that its products are free from defects in material and workmanship. Subject to conditions and limitations Laird will, at its option, either repair or replace any part of its products that prove defective by reason of improper workmanship or materials. This limited warranty is in force for the useful lifetime of the original end product into which the Laird product is installed. Useful lifetime of the original end product may vary but is not to exceed five (5) years from the original date of the end product purchase.



### SPECIFICATIONS - GPS

PARAMETER	PERFORMANCE		
Frequency Band	1575.42 MHz (GPS L1)		
Band Width	6 MHz (Typical)		
Amplifier Gain	27 dB ± 3 dBc		
Nominal Impedance	50 Ohm		
Output VSWR	< 1.5:1		
DC Voltage	2.7 -12 Vdc		
DC Current	20 mA (Nominal); <30 mA (-40°C to +85°C)		
Out-of-Band Signal Rejection	> 40 dB rejection @ ± 50 MHz from center frequency		
Intermodulation @ CW Mode (-40°C to +85°C)	Int1	Int2	IM3
	- 10 (1842.8 MHz)	- 10 (2110 MHz)	<- 100 (1575.6 MHz)
	- 10 (829.58 MHz)	- 10 (2405 MHz)	<- 100 (1575.42 MHz)
	- 10 (755.42 MHz)	- 10 (820 MHz)	<- 100 (1575.42 MHz)
Input 1 dB Compression @ 750 MHz, 2000 MHz & 3500 MHz	> 10dBm (-40°C to +85°C)		
Cable - Exposed Length	RG174-518.2 cm (17 ft.)		

### CONFIGURATION

PART NUMBER	CONNECTOR:	GPS	LTE	WiFi	UHF
FHQ69273CE-518VC3		SMA-male	SMA-male	SMA-male	PL259
FHQ69273CE-518VC4		SMA-male	SMA-male	SMA-male	FME Plug
FHQ69273CE-518VC5		SMA-male	SMA-male	RPSMA-male	PL259
FHQ69273CE-518VC6		SMA-male	SMA-male	RPSMA-male	FME Plug

### ANTENNA DRAWING

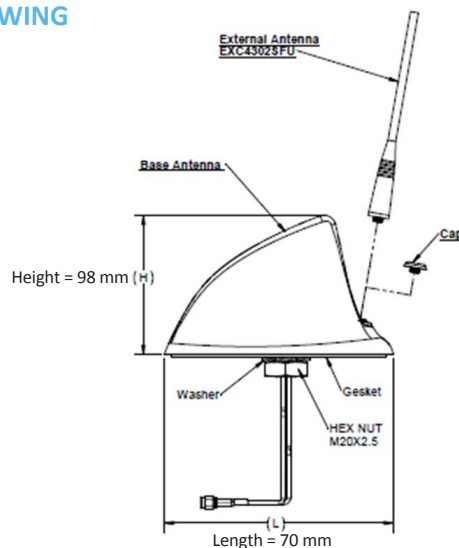

ANT-DS-PhantomFin\_FHQ69273CE\_0716

Any information furnished by Laird Inc. and its agents is believed to be accurate and reliable. All specifications are subject to change without notice. Responsibility for the use and application of Laird materials rests with the end user, since Laird and its agents cannot be aware of all potential uses. Laird makes no warranties as to the fitness, merchantability or suitability of any Laird materials or products for any specific or general uses. Laird shall not be liable for incidental or consequential damages of any kind. All Laird products are sold pursuant to the Laird Terms and Conditions of sale in effect from time to time, a copy of which will be furnished upon request. © Copyright 2016 Laird Inc. All Rights Reserved. Laird, Laird Technologies, the Laird Logo, and other marks are trade marks or registered trade marks of Laird Inc. or an affiliate company thereof. Other product or service names may be the property of third parties. Nothing herein provides a license under any Laird or any third party intellectual property rights.



Компания «ЭлектроПласт» предлагает заключение долгосрочных отношений при поставках импортных электронных компонентов на взаимовыгодных условиях!

Наши преимущества:

- Оперативные поставки широкого спектра электронных компонентов отечественного и импортного производства напрямую от производителей и с крупнейших мировых складов;
- Поставка более 17-ти миллионов наименований электронных компонентов;
- Поставка сложных, дефицитных, либо снятых с производства позиций;
- Оперативные сроки поставки под заказ (от 5 рабочих дней);
- Экспресс доставка в любую точку России;
- Техническая поддержка проекта, помощь в подборе аналогов, поставка прототипов;
- Система менеджмента качества сертифицирована по Международному стандарту ISO 9001;
- Лицензия ФСБ на осуществление работ с использованием сведений, составляющих государственную тайну;
- Поставка специализированных компонентов (Xilinx, Altera, Analog Devices, Intersil, Interpoint, Microsemi, Aeroflex, Peregrine, Syfer, Eurofarad, Texas Instrument, Miteq, Cobham, E2V, MA-COM, Hittite, Mini-Circuits, General Dynamics и др.);

Помимо этого, одним из направлений компании «ЭлектроПласт» является направление «Источники питания». Мы предлагаем Вам помощь Конструкторского отдела:

- Подбор оптимального решения, техническое обоснование при выборе компонента;
- Подбор аналогов;
- Консультации по применению компонента;
- Поставка образцов и прототипов;
- Техническая поддержка проекта;
- Защита от снятия компонента с производства.



#### Как с нами связаться

**Телефон:** 8 (812) 309 58 32 (многоканальный)

**Факс:** 8 (812) 320-02-42

**Электронная почта:** [org@eplast1.ru](mailto:org@eplast1.ru)

**Адрес:** 198099, г. Санкт-Петербург, ул. Калинина, дом 2, корпус 4, литера А.