

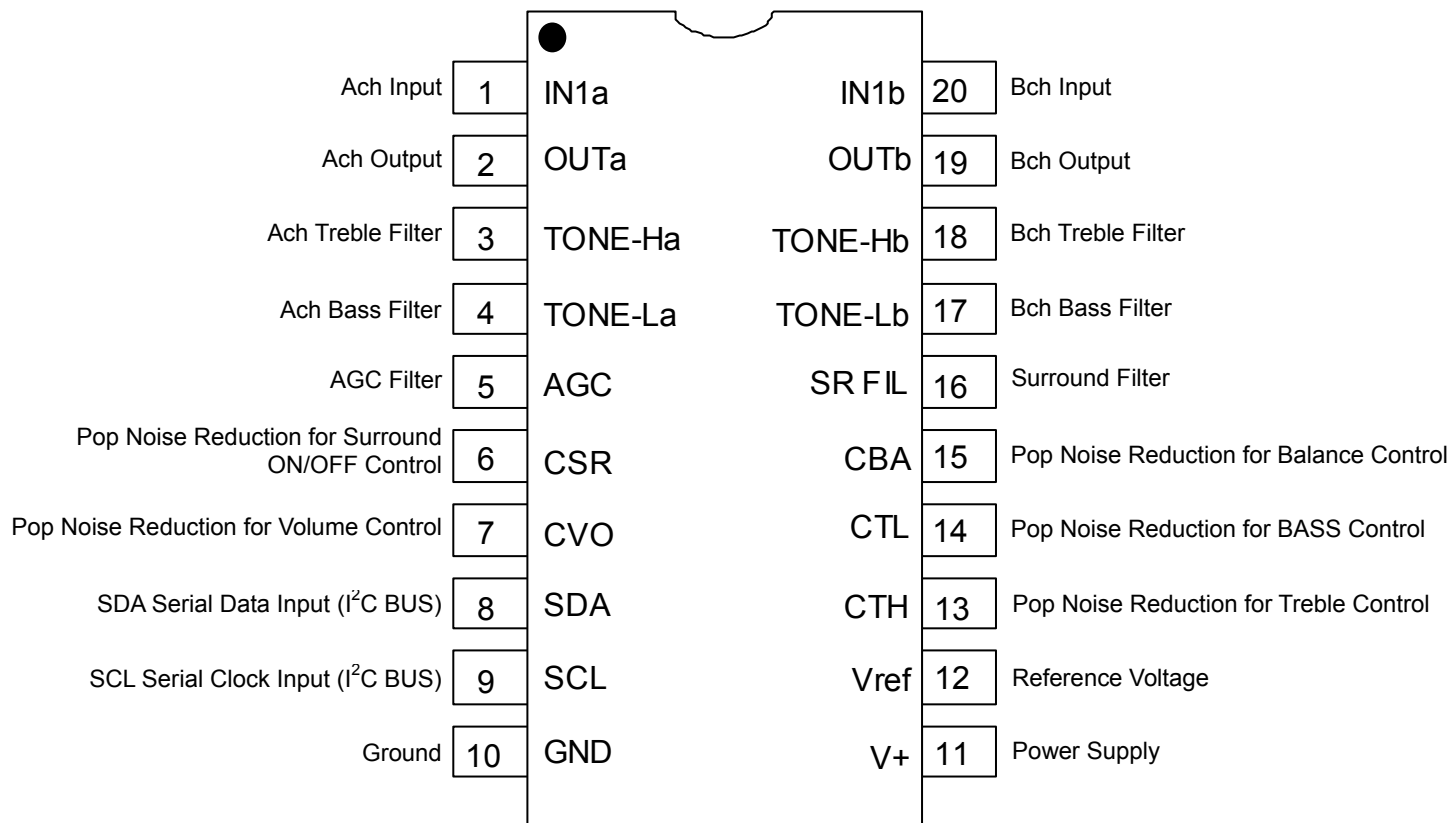

## ■ PIN CONFIGURATION



## ■ ABSOLUTE MAXIMUM RATING (Ta=25°C)

PARAMETER	SYMBOL	RATING	UNIT
Supply Voltage	V <sup>+</sup>	15	V
Power Dissipation	P <sub>D</sub>	350	mW
Operating Temperature Range	Topr	-20 to +75	°C
Storage Temperature Range	Tstg	-40 to +125	°C

## ■ ELECTRICAL CHARACTERISTICS (Ta=25°C, V+=9V, Rg=600Ω, RL=47kΩ, Vin=100mVrms/1kHz, AGC=OFF, TONE=0dB, Surround=OFF unless otherwise specified)

PARAMETER	SYMBOL	TEST CONDITION	MIN.	TYP.	MAX.	UNIT
Operating Voltage	V <sup>+</sup>		8.0	9.0	13.0	V
Supply Current	I <sub>CC</sub>	No Signal	-	13	25	mA
Reference Voltage	V <sub>REF</sub>	No Signal	4.0	4.5	5.0	V
Maximum Input Voltage	V <sub>IM</sub>	VOL=-20dB, THD=10%	2.8	3.0	-	Vrms
Maximum Output Voltage	V <sub>OM</sub>	OUTPUT VOL=0dB, THD=1%	-	2.5	-	Vrms
Channel Balance 1	G <sub>CB1</sub>	VOL=0dB	-1.0	0.0	1.0	dB
Channel Balance 2	G <sub>CB2</sub>	VOL=-70dB, Vin=1Vrms	-1.0	0.0	1.0	dB
Balance Boost A	BA <sub>BST</sub>	CHS="0", BAL="11111"	-2.0	0.0	2.0	dB
Balance Cut A	BA <sub>CUT</sub>	CHS="1", BAL="11111" Vin = 1Vrms	-	-	-70	dB
Balance Boost B	BB <sub>BST</sub>	CHS="1", BAL="11111"	-2.0	0.0	2.0	dB
Balance Cut B	BB <sub>CUT</sub>	CHS="0", BAL="11111" Vin = 1Vrms	-	-	-70	dB
Total Harmonic Distortion	THD	Vo=0.5Vrms BW=400Hz to 30kHz	-	-	0.3	%
Maximum Gain	G <sub>VMAX</sub>	VOL= 0dB	-2.0	0.0	2.0	dB
Minimum Gain	G <sub>VMIN</sub>	VOL= MUTE, Vin=2Vrms	-	-100	-90	dB
Channel Separation	CS	Vin = 1Vrms A-weighting	-	-80	-70	dB
Output Noise 1	V <sub>NO1</sub>	VOL = 0dB A-weighting	-	-90 (31.6)	-85 (56.2)	dBV (μVrms)
Output Noise 2	V <sub>NO2</sub>	VOL = MUTE A-weighting	-	-106 (5.0)	-96 (15.8)	dBV (μVrms)

BW: Band Width

■ **ELECTRICAL CHARACTERISTICS** (Ta=25°C, V+=9V, Rg=600Ω, RL=47kΩ, Vin=100mVrms/1kHz, AGC=OFF, TONE=0dB, Surround=OFF unless otherwise specified)

◆ **TONE CONTROL**

PARAMETER	SYMBOL	TEST CONDITION	MIN.	TYP.	MAX.	UNIT
High Frequency Boost	HF <sub>BST</sub>	BCT="1", TREB="1111", f=10kHz	12.5	15.0	17.5	dB
High Frequency Flat	HF <sub>FLT</sub>	TREB="0000", f=10kHz	-2.0	0.0	2.0	dB
High Frequency Cut	HF <sub>CUT</sub>	BCT="0", TREB="1111", f=10kHz	-17.5	-15.0	-12.5	dB
Low Frequency Boost	LF <sub>BST</sub>	BCB="1", BASS="1111", f=100Hz	12.5	15.0	17.5	dB
Low Frequency Flat	LF <sub>FLT</sub>	BASS="0000", f=100Hz	-2.0	0.0	2.0	dB
Low Frequency Cut	LF <sub>CUT</sub>	BCB="0", BASS="1111", f=100Hz	-17.5	-15.0	-12.5	dB

◆ **AGC CONTROL (AGC-ON)**

PARAMETER	SYMBOL	TEST CONDITION	MIN.	TYP.	MAX.	UNIT
AGC Boost	AGC <sub>BST</sub>	Vin=50mVrms, f=1kHz	1.5	3.5	5.5	dB
AGC Flat1	AGC <sub>FLT1</sub>	Vin=100mVrms, f=1kHz	-2.5	0.0	2.5	dB
AGC Flat2	AGC <sub>FLT2</sub>	Vin=200mVrms, f=1kHz	-2.5	0.0	2.5	dB
AGC Flat3	AGC <sub>FLT3</sub>	Vin=300mVrms, f=1kHz	-2.5	0.0	2.5	dB
AGC Flat4	AGC <sub>FLT4</sub>	Vin=400mVrms, f=1kHz	-2.5	0.0	2.5	dB

◆ **SURROUND (SURROUND-ON)**

PARAMETER	SYMBOL	TEST CONDITION	MIN.	TYP.	MAX.	UNIT
Surround Gain1	SR <sub>GAIN1</sub>	Ain→Aout, f=100Hz SUR0="1", SUR="1"	6.0	8.0	10.0	dB
Surround Gain2	SR <sub>GAIN2</sub>	Ain→Bout, f=100Hz SUR0="1", SUR="1"	1.6	3.6	5.6	dB
Surround Gain3	SR <sub>GAIN3</sub>	Ain→Aout, f=100Hz SUR0="0", SUR="1"	10.0	12.0	14.0	dB
Surround Gain4	SR <sub>GAIN4</sub>	Ain→Bout, f=100Hz SUR0="0", SUR="1"	7.5	9.5	11.5	dB
Simulated Surround Gain1	SR <sub>SIM1</sub>	Ain+Bin→Aout, f=1kHz SUR0="1", SUR="0"	1.0	3.0	5.0	dB
Simulated Surround Gain2	SR <sub>SIM2</sub>	Ain+Bin→Bout, f=1kHz SUR0="1", SUR="0"	1.0	3.0	5.0	dB

## ■TIMING ON THE I<sup>2</sup>C BUS (SDA,SCL)

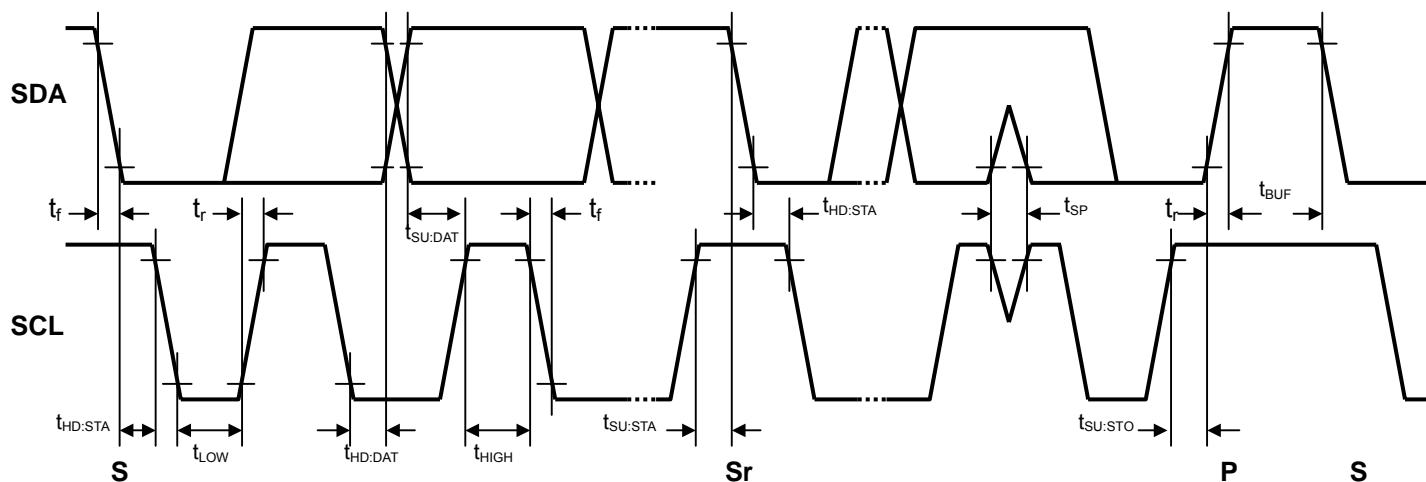

## ■CHARACTERISTICS OF I/O STAGES FOR I<sup>2</sup>C BUS (SDA,SCL)

I<sup>2</sup>C BUS Load Conditions

STANDARD MODE : Pull up resistance 4kΩ (Connected to +5V), Load capacitance 200pF (Connected to GND)

FAST MODE : Pull up resistance 4kΩ (Connected to +5V), Load capacitance 50pF (Connected to GND)

PARAMETER	SYMBOL	Standard mode			Fast mode			UNIT
		MIN.	TYP.	MAX.	MIN.	TYP.	MAX.	
Low Level Input Voltage	V <sub>IL</sub>	0.0	-	1.5	0.0	-	1.5	V
High Level Input Voltage	V <sub>IH</sub>	2.7	-	5.0	2.7	-	5.0	V
Low level output voltage (3mA at SDA pin)	V <sub>OL</sub>	0	-	0.4	0	-	0.4	V
Input current each I/O pin with an input voltage between 0.1V <sub>DD</sub> and 0.9V <sub>DDmax</sub>	I <sub>i</sub>	-10	-	10	-10	-	10	μA

## ■CHARACTERISTICS OF BUS LINES (SDA,SCL) FOR I<sup>2</sup>C-BUS DEVICES

PARAMETER	SYMBOL	Standard mode			Fast mode			UNIT
		MIN.	TYP.	MAX.	MIN.	TYP.	MAX.	
SCL clock frequency	f <sub>SCL</sub>	-	-	100	-	-	400	kHz
Hold time (repeated) START condition.	t <sub>HD:STA</sub>	4.0	-	-	0.6	-	-	μs
Low period of the SCL clock	t <sub>LOW</sub>	4.7	-	-	1.3	-	-	μs
High period of the SCL clock	t <sub>HIGH</sub>	4.0	-	-	0.6	-	-	μs
Set-up time for a repeated START condition	t <sub>SU:STA</sub>	4.7	-	-	0.6	-	-	μs
Data hold time <sup>(NOTE)</sup>	t <sub>HD:DAT</sub>	0	-	-	0	-	-	μs
Data set-up time	t <sub>SU:DAT</sub>	250	-	-	100	-	-	ns
Rise time of both SDA and SCL signals	t <sub>r</sub>	-	-	1000	-	-	300	ns
Fall time of both SDA and SCL signals	t <sub>f</sub>	-	-	300	-	-	300	ns
Set-up time for STOP condition	t <sub>SU:STO</sub>	4.0	-	-	0.6	-	-	μs
Bus free time between a STOP and START condition	t <sub>BUF</sub>	4.7	-	-	1.3	-	-	μs
Capacitive load for each bus line	C <sub>b</sub>	-	-	400	-	-	400	pF
Noise margin at the Low level	V <sub>nL</sub>	0.5	-	-	0.5	-	-	V
Noise margin at the High level	V <sub>nH</sub>	1	-	-	1	-	-	V

C<sub>b</sub> ; total capacitance of one bus line in pF.

NOTE). Data hold time : t<sub>HD:DAT</sub>

Please hold the Data Hold Time (t<sub>HD:DAT</sub>) to 300ns or more to avoid status of unstable at SCL falling edge.

The SDA block in the NJW1173 does not hold data. Add external data-delay-circuit of the SDA terminal, in case of not providing a hold time of at least 300nsec for the SDA in the master device.

The time-consists of the data-delay-circuit of the SDA terminal are as follows.

- (a) Low level → High level :  $T_{LH} \approx R_p \cdot C_D$
- (b) High level → Low level :  $T_{HL} \approx R_D \cdot C_D$

In addition, Schottky barrier diode (SBD) influences a Low level at the Acknowledge. Therefore choose the low forward voltage (V<sub>f</sub>) as much as possible.

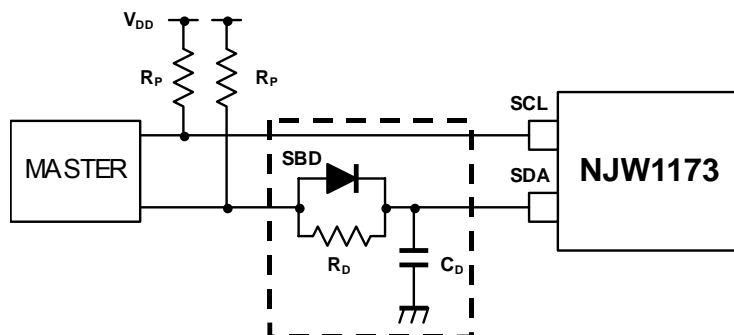

## ■ TERMINAL DESCRIPTION

No.	SYMBOL	FUNCTION	EQUIVALENT CIRCUIT	VOLTAGE
1 20	INa INb	Ach Input terminal Bch Input terminal		$V^+/2$
2 19	OUTa OUTb	Ach Output terminal Bch Output terminal		$V^+/2$
3 18	TONE-Ha TONE-Hb	Ach Treble Filter terminal Bch Treble Filter terminal		$V^+/2$
4 17	TONE-La TONE-Lb	Ach Bass Filter terminal Bch Bass Filter terminal		$V^+/2$
5	AGC	Capacitor connection terminal for AGC attack and recovery time setting		1.4V

## ■ TERMINAL DESCRIPTION

No.	SYMBOL	FUNCTION	EQUIVALENT CIRCUIT	VOLTAGE
6	CSR	Pop Noise Reduction for Surround ON/OFF Control		$V^+/2$
7	CVO	Pop Noise Reduction for Volume Control		$V^+/2$
8	SDA	SDA Serial Data Input (I <sup>2</sup> C BUS)		
9	SCL	SDA Serial Clock Input (I <sup>2</sup> C BUS)		
10	GND	Ground terminal	-	-
11	V+	Power Supply terminal	-	-
12	Vref	Reference Voltage		$V^+/2$



■ TERMINAL DESCRIPTION

No.	SYMBOL	FUNCTION	EQUIVALENT CIRCUIT	VOLTAGE
13	CTH	Pop Noise Reduction for Treble Control		V <sup>+</sup> /2
14	CTL	Pop Noise Reduction for Bass Control		
15	CBA	Pop Noise Reduction for Balance Control		
16	SRFIL	Surround filter terminal		V <sup>+</sup> /2

## APPLICATION CIRCUIT

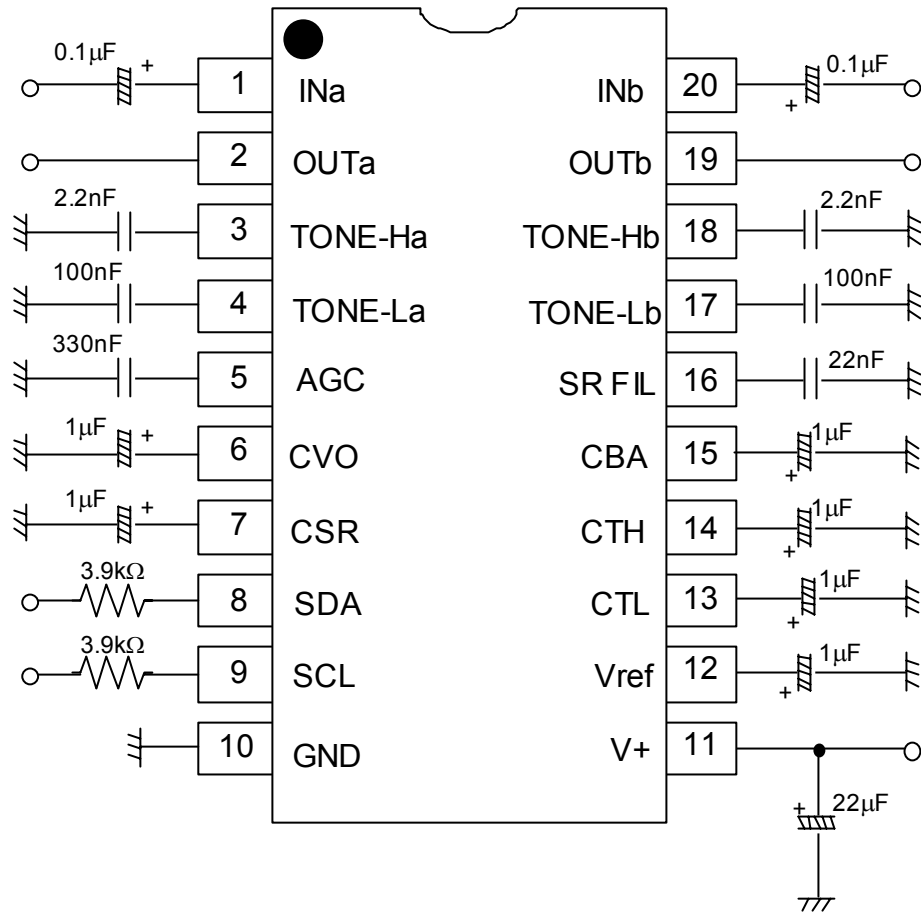

(NOTE) Separate the I<sup>2</sup>C bus line from the following terminals for avoiding digital noise problem.

Pin No.	Symbol	Pin No.	Symbol	Pin No.	Symbol
3	TONE-Ha	16	SR FIL	18	TONE-Hb
4	TONE-La	17	TONE-Lb	-	-

## ■ DEFINITION OF I<sup>2</sup>C REGISTER

### ● I<sup>2</sup>C BUS FORMAT



S: Starting Term  
A: Acknowledge Bit  
P: Ending Term

### ● SLAVE ADDRESS



$\overline{R/W}=0$ : Write mode for register setting  
 $\overline{R/W}=1$ : Not available

### ● CONTROL REGISTER TABLE

The select address sets each function (Volume, Balance, AGC, Tone Control, Surround etc.).  
The auto-increment function cycles the select address as follows.  
00H→01H→02H→03H→00H

Select Address	BIT							
	D7	D6	D5	D4	D3	D2	D1	D0
00H	VOL							
01H	CHS	BAL					SUR	
02H	BCB	BASS			AGC-SW		AGC-FLAT	
03H	BCT	TREB			Don't Care			

### ● CONTROL REGISTER DEFAULT VALUE

Control register default value is all "0".

Select Address	BIT							
	D7	D6	D5	D4	D3	D2	D1	D0
00H	0	0	0	0	0	0	0	0
01H	0	0	0	0	0	0	0	0
02H	0	0	0	0	0	0	0	0
03H	0	0	0	0	0	0	0	0

## ■ I<sup>2</sup>C CONTROL COMMAND DESCRIPTION

### ● MASTER VOLUME CONTROL

Select Address	BIT							
	D7	D6	D5	D4	D3	D2	D1	D0
00H	VOL							

The volume controls both Ach and Bch by the 0.5dB step.

The volume is consisted of volume1 and volume2. The level is divided into half to each volume1 and volume2.

### ● BALANCE, AGC AND INPUT SELECTOR SETTINGS

Select Address	BIT							
	D7	D6	D5	D4	D3	D2	D1	D0
01H	CHS	BAL					SUR	

- CHS: Channel select for balance control

“0”: Ach “Bch is attenuated”

“1”: Bch “Ach is attenuated”

- BAL: Balance control for both Ach and Bch (1dB/Step)

The balance is consisted of volume2 alone. Volume1 does not operate on balance.

- SUR : Surround Setting

Surround Setting	SUR		Remarks
	D1	D0	
Surround OFF	0	0	Input through
Simulated Stereo mode	0	1	For monaural signal input only
"eala" High mode	1	0	Surround Effect Small ( 8.0dB typ. )
"eala" Low mode	1	1	Surround Effect Large (12.0dB typ. )

### ● TONE CONTROL (Bass) and AGC SETTINGS

Select Address	BIT							
	D7	D6	D5	D4	D3	D2	D1	D0
02H	BCB	BASS				AGC-SW	AGC-FLAT	

- BCB : Bass Boost or Cut

“0” : Cut

“1” : Boost

- BASS : BASS Level

Cut Level : -15 to 0dB(1dB/Step)

Boost Level : 0 to +15dB(1dB/Step)

- AGC-SW : AGC ON/OFF Switch

“0” : AGC OFF

“1” : AGC ON (Default : 100mVrms)

- AGC-FLAT : AGC Flat Level

AGC Flat Level	AGC-FLAT	
	D1	D0
100mVrms	0	0
200mVrms	0	1
300mVrms	1	0
400mVrms	1	1

## ●TONE CONTROL (Treble) SETTINGS

Select Address	BIT							
	D7	D6	D5	D4	D3	D2	D1	D0
<b>03H</b>	BCT	TREB				Don't Care		

- BCT : Treble Boost or Cut  
   "0" : Cut  
   "1" : Boost
- TREB : Treble Level  
   Cut Level : -15 to 0dB(1dB/Step)

■ Master Volume (Select Address: 00H)

		VOL							
Gain(dB)	HEX	D7	D6	D5	D4	D3	D2	D1	D0
0	FF	1	1	1	1	1	1	1	1
-1	FD	1	1	1	1	1	1	0	1
-2	FB	1	1	1	1	1	0	1	1
-3	F9	1	1	1	1	1	0	0	1
-4	F7	1	1	1	1	0	1	1	1
-5	F5	1	1	1	1	0	1	0	1
-6	F3	1	1	1	1	0	0	1	1
-7	F1	1	1	1	1	0	0	0	1
-8	EF	1	1	1	0	1	1	1	1
-9	ED	1	1	1	0	1	1	0	1
-10	EB	1	1	1	0	1	0	1	1
-11	E9	1	1	1	0	1	0	0	1
-12	E7	1	1	1	0	0	1	1	1
-13	E5	1	1	1	0	0	1	0	1
-14	E3	1	1	1	0	0	0	1	1
-15	E1	1	1	1	0	0	0	0	1
-16	DF	1	1	0	1	1	1	1	1
-17	DD	1	1	0	1	1	1	0	1
-18	DB	1	1	0	1	1	0	1	1
-19	D9	1	1	0	1	1	0	0	1
-20	D7	1	1	0	1	0	1	1	1
-21	D5	1	1	0	1	0	1	0	1
-22	D3	1	1	0	1	0	0	1	1
-23	D1	1	1	0	1	0	0	0	1
-24	CF	1	1	0	0	1	1	1	1
-25	CD	1	1	0	0	1	1	0	1
-26	CB	1	1	0	0	1	0	1	1
-27	C9	1	1	0	0	1	0	0	1
-28	C7	1	1	0	0	0	1	1	1
-29	C5	1	1	0	0	0	1	0	1
-30	C3	1	1	0	0	0	0	1	1
-31	C1	1	1	0	0	0	0	0	1
-32	BF	1	0	1	1	1	1	1	1
-33	BD	1	0	1	1	1	1	0	1
-34	BB	1	0	1	1	1	0	1	1
-35	B9	1	0	1	1	1	0	0	1
-36	B7	1	0	1	1	0	1	1	1
-37	B5	1	0	1	1	0	1	0	1
-38	B3	1	0	1	1	0	0	1	1
-39	B1	1	0	1	1	0	0	0	1
-40	AF	1	0	1	0	1	1	1	1
-41	AD	1	0	1	0	1	1	0	1
-42	AB	1	0	1	0	1	0	1	1

## ■MASTER VOLUME (Cont'd)

		VOL							
Gain(dB)	HEX	D7	D6	D5	D4	D3	D2	D1	D0
-43	A9	1	0	1	0	1	0	0	1
-44	A7	1	0	1	0	0	1	1	1
-45	A5	1	0	1	0	0	1	0	1
-46	A3	1	0	1	0	0	0	1	1
-47	A1	1	0	1	0	0	0	0	1
-48	9F	1	0	0	1	1	1	1	1
-49	9D	1	0	0	1	1	1	0	1
-50	9B	1	0	0	1	1	0	1	1
-51	99	1	0	0	1	1	0	0	1
-52	97	1	0	0	1	0	1	1	1
-53	95	1	0	0	1	0	1	0	1
-54	93	1	0	0	1	0	0	1	1
-55	91	1	0	0	1	0	0	0	1
-56	8F	1	0	0	0	1	1	1	1
-57	8D	1	0	0	0	1	1	0	1
-58	8B	1	0	0	0	1	0	1	1
-59	89	1	0	0	0	1	0	0	1
-60	87	1	0	0	0	0	1	1	1
-61	85	1	0	0	0	0	1	0	1
-62	83	1	0	0	0	0	0	1	1
-63	81	1	0	0	0	0	0	0	1
-64	7F	0	1	1	1	1	1	1	1
-65	7D	0	1	1	1	1	1	0	1
-66	7B	0	1	1	1	1	0	1	1
-67	79	0	1	1	1	1	0	0	1
-68	77	0	1	1	1	0	1	1	1
-69	75	0	1	1	1	0	1	0	1
-70	73	0	1	1	1	0	0	1	1
-71	71	0	1	1	1	0	0	0	1
-72	6F	0	1	1	0	1	1	1	1
-73	6D	0	1	1	0	1	1	0	1
-74	6B	0	1	1	0	1	0	1	1
-75	69	0	1	1	0	1	0	0	1
-76	67	0	1	1	0	0	1	1	1
-77	65	0	1	1	0	0	1	0	1
-78	63	0	1	1	0	0	0	1	1
-79	61	0	1	1	0	0	0	0	1
-80	5F	0	1	0	1	1	1	1	1
⋮	⋮	⋮	⋮	⋮	⋮	⋮	⋮	⋮	⋮
⋮	⋮	⋮	⋮	⋮	⋮	⋮	⋮	⋮	⋮
-90	4B	0	1	0	0	1	0	1	1
⋮	⋮	⋮	⋮	⋮	⋮	⋮	⋮	⋮	⋮
⋮	⋮	⋮	⋮	⋮	⋮	⋮	⋮	⋮	⋮
-100	37	0	0	1	1	0	1	1	1
Mute	00	0	0	0	0	0	0	0	0

■ Balance (Select Address: 01H)

Channel Setting	CHS
	D7
Attenuated Bch Gain	0
Attenuated Ach Gain	1

Gain(dB)	BAL				
	D6	D5	D4	D3	D2
0	0	0	0	0	0
-1	0	0	0	0	1
-2	0	0	0	1	0
-3	0	0	0	1	1
-4	0	0	1	0	0
-5	0	0	1	0	1
-6	0	0	1	1	0
-7	0	0	1	1	1
-8	0	1	0	0	0
-9	0	1	0	0	1
-10	0	1	0	1	0
-11	0	1	0	1	1
-12	0	1	1	0	0
-13	0	1	1	0	1
-14	0	1	1	1	0
-15	0	1	1	1	1
-16	1	0	0	0	0
-17	1	0	0	0	1
-18	1	0	0	1	0
-19	1	0	0	1	1
-20	1	0	1	0	0
-21	1	0	1	0	1
-22	1	0	1	1	0
-23	1	0	1	1	1
-24	1	1	0	0	0
-25	1	1	0	0	1
-26	1	1	0	1	0
-27	1	1	0	1	1
-28	1	1	1	0	0
-29	1	1	1	0	1
-30	1	1	1	1	0
MUTE	1	1	1	1	1



## ■ Tone Control Bass (Select Address: 02H)

Bass	BCB
Cut or Boost	D7
Cut	0
Boost	1

		BASS			
Cut Gain(dB)	Boost Gain(dB)	D6	D5	D4	D3
-15	15	1	1	1	1
-14	14	1	1	1	0
-13	13	1	1	0	1
-12	12	1	1	0	0
-11	11	1	0	1	1
-10	10	1	0	1	0
-9	9	1	0	0	1
-8	8	1	0	0	0
-7	7	0	1	1	1
-6	6	0	1	1	0
-5	5	0	1	0	1
-4	4	0	1	0	0
-3	3	0	0	1	1
-2	2	0	0	1	0
-1	1	0	0	0	1
0	0	0	0	0	0

## ■ Tone Control Treble (Select Address: 03H)

Treble	BCT
Cut or Boost	D7
Cut	0
Boost	1

		TREB			
Cut Gain(dB)	Boost Gain(dB)	D6	D5	D4	D3
-15	15	1	1	1	1
-14	14	1	1	1	0
-13	13	1	1	0	1
-12	12	1	1	0	0
-11	11	1	0	1	1
-10	10	1	0	1	0
-9	9	1	0	0	1
-8	8	1	0	0	0
-7	7	0	1	1	1
-6	6	0	1	1	0
-5	5	0	1	0	1
-4	4	0	1	0	0
-3	3	0	0	1	1
-2	2	0	0	1	0
-1	1	0	0	0	1
0	0	0	0	0	0

**[CAUTION]**

The specifications on this databook are only given for information, without any guarantee as regards either mistakes or omissions. The application circuits in this databook are described only to show representative usages of the product and not intended for the guarantee or permission of any right including the industrial rights.

# Mouser Electronics

Authorized Distributor

Click to View Pricing, Inventory, Delivery & Lifecycle Information:

[NJR:](#)

[NJW1173V-TE1](#)



Компания «ЭлектроПласт» предлагает заключение долгосрочных отношений при поставках импортных электронных компонентов на взаимовыгодных условиях!

Наши преимущества:

- Оперативные поставки широкого спектра электронных компонентов отечественного и импортного производства напрямую от производителей и с крупнейших мировых складов;
- Поставка более 17-ти миллионов наименований электронных компонентов;
- Поставка сложных, дефицитных, либо снятых с производства позиций;
- Оперативные сроки поставки под заказ (от 5 рабочих дней);
- Экспресс доставка в любую точку России;
- Техническая поддержка проекта, помощь в подборе аналогов, поставка прототипов;
- Система менеджмента качества сертифицирована по Международному стандарту ISO 9001;
- Лицензия ФСБ на осуществление работ с использованием сведений, составляющих государственную тайну;
- Поставка специализированных компонентов (Xilinx, Altera, Analog Devices, Intersil, Interpoint, Microsemi, Aeroflex, Peregrine, Syfer, Eurofarad, Texas Instrument, Miteq, Cobham, E2V, MA-COM, Hittite, Mini-Circuits, General Dynamics и др.);

Помимо этого, одним из направлений компании «ЭлектроПласт» является направление «Источники питания». Мы предлагаем Вам помощь Конструкторского отдела:

- Подбор оптимального решения, техническое обоснование при выборе компонента;
- Подбор аналогов;
- Консультации по применению компонента;
- Поставка образцов и прототипов;
- Техническая поддержка проекта;
- Защита от снятия компонента с производства.



#### Как с нами связаться

**Телефон:** 8 (812) 309 58 32 (многоканальный)

**Факс:** 8 (812) 320-02-42

**Электронная почта:** [org@eplast1.ru](mailto:org@eplast1.ru)

**Адрес:** 198099, г. Санкт-Петербург, ул. Калинина, дом 2, корпус 4, литера А.