

YAMAICHI ELECTRONICS

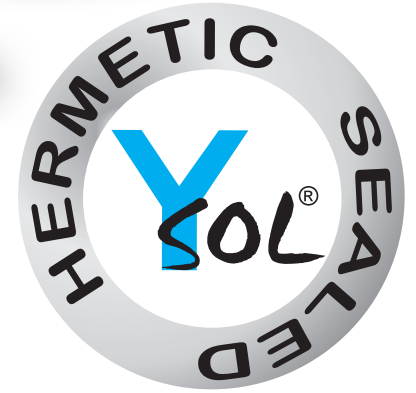

Y-Sol[®] Photovoltaic
Cable Assemblies
Connectors and
Junction Boxes

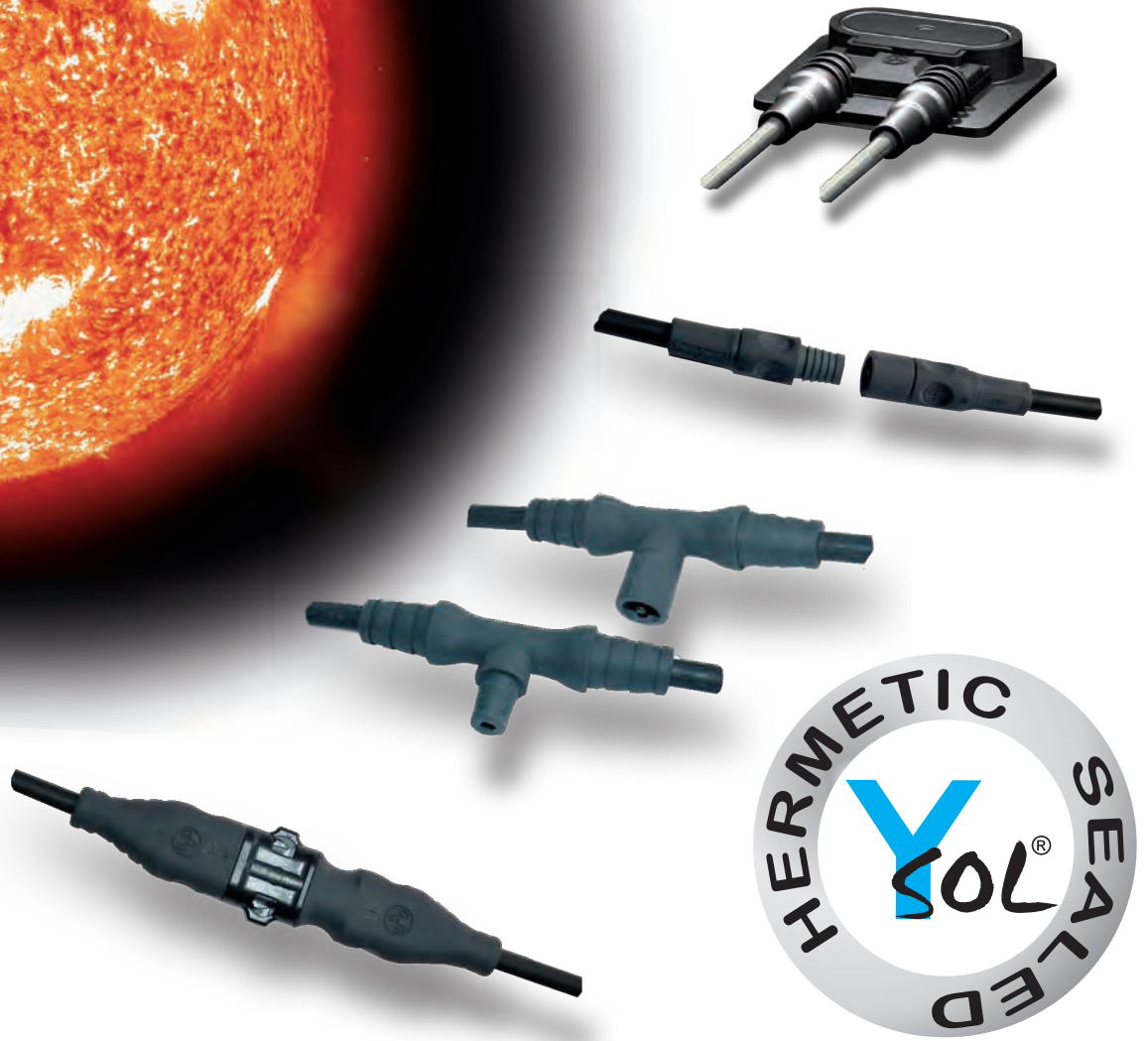

Why Hermetic Sealed?



One Step Process

What is the meaning of Hermetic Sealed?

Hermetic Sealed is a one step overmolding process.

In a one step process the connector is molded into its final shape and makes a solid connection with the cable. No screws or extra parts are needed. The overmolding forms a permanent hermetic sealing around the cable and contact (*fig 1*).

Yamaichi has developed this technology for the connectors Y-Sol3, Y-Sol3 T-Junction, Y-Sol4 and for the Thin Film Junction Box. These products come ready-to-plug to the customer. 100% tested for easy and safe assembly.

For worldwide usage, the products are tested and certified by TÜV and UL.

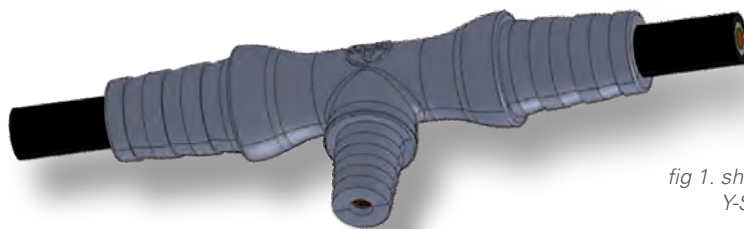
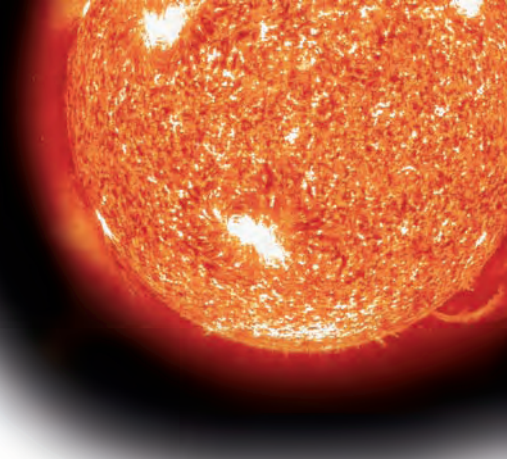

fig 1. shows a 3D Hermetic Sealed Y-Sol3 T-Junction

Customer advantages with our cable assemblies

The Hermetic Sealed technology combines the advantages of cost and quality

- Less installation time required because of overmolded cable assemblies which are pre-assembled and "ready-to-plug".
- Permanent and safe operation of the PV plant. Y-Sol® connectors fulfil the IP68 protection class. The overmolding process protects the inner parts and contacts.
- Safe power transmission of up to 30A.
- Standard products are available as well as customised solutions.
- Long life time of the complete assembly even under harsh environmental conditions.
- Cross linked cables are used as standard.



Customer advantages with our Thin Film Junction Box

The TF J-Box from Yamaichi is delivered with cables and overmolded connectors. In addition to the advantages of our cable assemblies, the Hermetic Sealed TF J-Box has the following features:

- Delivered as a pre-assembled Hermetic Sealed system, complete with cables and connectors.
- Configuration according to customer requirements.
- Fully overmolded integrated bypass diode. This guarantees safe operation under different lighting conditions or shadowing.
- The Hermetic Sealed diode is homogeneously surrounded by plastic material. Heat generated by the diode is absorbed. This means reduced stress on the diode and longer life time (fig 2).

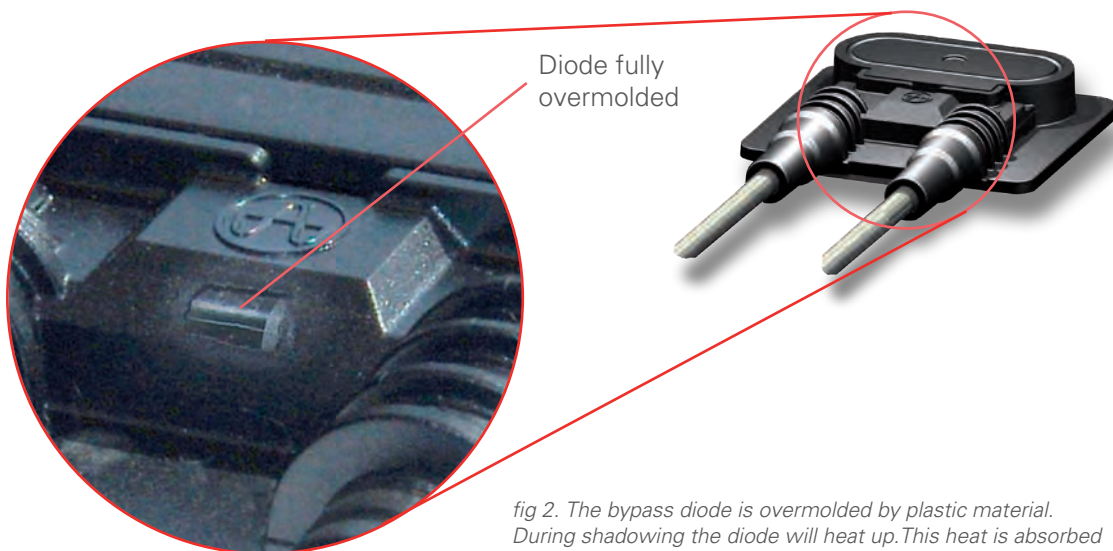
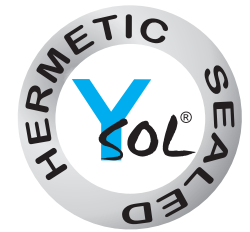

fig 2. The bypass diode is overmolded by plastic material. During shadowing the diode will heat up. This heat is absorbed and eliminated. The plastic material has a 30 times higher heat conductivity than air.

Y-Sol3 Cable Assemblies

Y-Sol3 connector is a ready-made solar cable assembly,
 “ready-to-plug” in your PV installation.
 100% controlled quality by Yamaichi.



Ready-to-Plug

Y-Sol3

Ø 3mm contacts without locking



Certified: acc. to EN50521 (TÜV)
 acc. to UL 1703



Part Number (example) and various combinations

Y-SOL3AOV - F1 - 4U - 1000 - GM*

Series No.
 for Overmolded
 (Hermetic Sealed)

M1 = Male
 (with Partial Strip off)

F1 = Female
 (with Partial Strip off)

M2 = Male (with Blank Cut)

F2 = Female (with Blank Cut)

Cable Cross Section

2T = 2.5mm², with TÜV

4U = 4.0mm², with TÜV and UL

4T = 4.0mm², with TÜV

6T = 6.0mm², with TÜV

Overall Length in mm (e.g. 1000 = 1 meter)

GM* = Internal Style No. (determined by Yamaichi)

For final part numbers please contact Yamaichi before ordering

Specifications

Description	Y-SOL3
Diameter	Ø13.5mm
Degree of protection	IP68 (plugged) and IP20 (unplugged)
Protection class	II
Cable cross section	2.5mm ² , 4.0mm ² and 6.0mm ²
Ambient temperature	-40°C to +85°C
Contact resistance	< 5mΩ (typ. value 1mΩ up to 3mΩ)
Voltage rating	1,000 V DC acc. to TÜV EN50521 600 V DC acc. to UL 1703
Current rating	30A (based on 4mm ² cross section)
Extraction force	≥ 89 Newton
Cable pull-out force	≥ 350 Newton

Y-Sol3 T-Junction Assemblies

Y-Sol3 T-Junction is a ready-made solar cable assembly, “ready-to-plug” in your PV installation. It is made according to customer requirements. The number of T-Junctions and adapter cables can be freely specified. 100% controlled quality by Yamaichi.



Y-Sol3 T-Junction

Ø 3mm overmolded cable harness for connection of PV panels in parallel configuration.



Certified: acc. to EN50521 (TÜV)
acc. to UL 1703

Part Number (example) and various combinations

Y-SOL3T - F 4 3 - 6T - 3200 - GM*

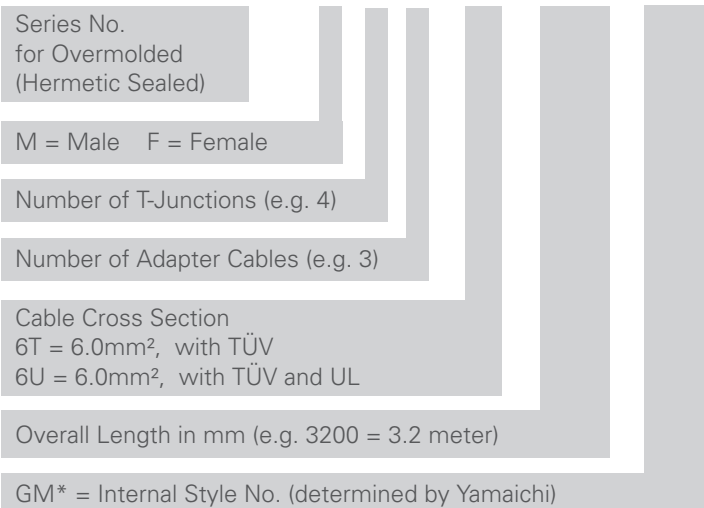

For final part numbers please contact Yamaichi before ordering

Specifications

Description	Y-SOL3 T-Junction
Diameter	Ø17mm
Degree of protection	IP68 (plugged) and IP20 (unplugged)
Protection class	II
Cable cross section	6.0mm ²
Ambient temperature	-40°C to +85°C
Contact resistance	< 5mΩ (typ. value 1mΩ up to 3mΩ)
Voltage rating	1,000 V DC acc. to TÜV EN50521 600 V DC acc. to UL 1703
Current rating	30A (based on 6mm ²)
Extraction force	≥ 89 Newton
Cable pull-out force	≥ 350 Newton

Y-Sol4 Cable Assemblies

Y-Sol4 is a ready-made solar cable assembly, “ready-to-plug” in your PV installation. The Y-Sol4 connector has a security locking function. Once closed a release tool is necessary to re-open the connection. 100% controlled quality by Yamaichi.



Ready-to-Plug

Y-Sol4

Ø 4mm contacts with locking



Y-SOL4 release tool

Part Number
Y-SOL4-RELEASE-TOOL-SR



Certified: acc. to EN50521 (TÜV)
acc. to UL 1703

Part Number (example) and various combinations

Y-SOL4AOV - M1 - 4T - 1000 - GM*

Series No.
for Overmolded
(Hermetic Sealed)

M1 = Male
(with Partial Strip off)

F1 = Female
(with Partial Strip off)

M2 = Male (with Blank Cut)

F2 = Female (with Blank Cut)

Cable Cross Section

1U = 1.5mm², with TÜV and UL

2U = 2.5mm², with TÜV and UL

4T = 4.0mm², with TÜV

Overall Length in mm (e.g. 1000 = 1 meter)

GM* = Internal Style No. (determined by Yamaichi)

For final part numbers please contact Yamaichi before ordering

Specifications

Description	Y-SOL4
Height	12mm
Degree of protection	IP68 (plugged) and IP20 (unplugged)
Protection class	II
Cable cross section	1.5mm ² , 2.5mm ² and 4.0mm ²
Ambient temperature	-40°C to +85°C
Contact resistance	< 5mΩ (typ. value 1mΩ up to 3mΩ)
Voltage rating	1,000 V DC acc. to TÜV EN50521 600 V DC acc. to UL 1703
Current rating	30A (based on 4mm ² cross section)
Extraction force	≥ 89 Newton
Cable pull-out force	≥ 350 Newton

Y-Sol4 Crimp Assembly Connector (C.A.T.)

The Y-Sol4 C.A.T. (Crimp Assembly Type) is a connector for field installation by crimp connection. The connector comes in male and female types and has only two parts to connect with the cable. The cable is assembled by using a standard crimp tool. This crimping can be done manually or automatically.

Crimp Type



Y-Sol4 C.A.T.

Ø 4mm contacts - crimp type assembly

Customer Advantages

- ✓ For manual or automatic assembly
- ✓ Two piece design
- ✓ Installation with a standard crimp tool



in preparation



in preparation

Y-Sol4 C.A.T. Male Connector



Part Number (example) and various combinations

PVP0402 - 102 - 02 02 - 00*

Series No. for
Crimp Assembly Type
PVP0402 = Plug
PVS0402 = Socket

Crimp Type Unit Packaging

Cable Cross Section
01 = 1.5mm² to 2.5mm²
02 = 4.0mm² to 6.0mm²

Cable Outer Dimension
02 = 5.8mm up to 7.0mm
(other diameters are being planned)

00* = Internal Style No. (determined by Yamaichi)

For final part numbers please contact Yamaichi before ordering

Y-Sol4 C.A.T. Female Connector

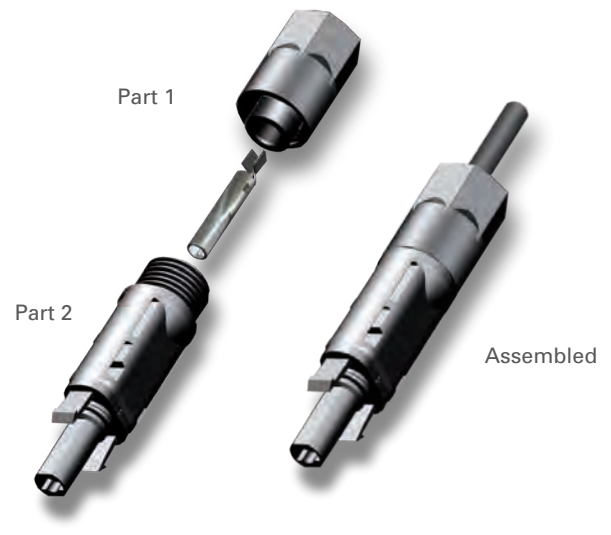

For Specifications please refer to table on next page

Y-Sol4 Free Assembly Connector (F.A.T.)

The Y-Sol4 F.A.T. (Free Assembly Type) is a connector for fast and safe field installation. The connector comes in male and female types and has only two parts to connect with the cable. The assembly is closed by simply screwing the two parts together. There are absolutely no tools for this operation required.



Tool Free

Y-Sol4 F.A.T.

Ø 4mm contacts - spring type assembly

Customer Advantages

- ✓ No tool required
- ✓ Two piece design
- ✓ Installation in just three steps



in preparation



in preparation

Y-Sol4 F.A.T. Male Connector



Y-Sol4 F.A.T. Female Connector



Part Number (example) and various combinations

PVP0402 - 202 - 02 02 - 00*

Series No. for
Free Assembly Type
PVP0402 = Plug
PVS0402 = Socket

Spring Type Unit Packaging

Cable Cross Section
01 = 1.5mm² to 2.5mm²
02 = 4.0mm² to 6.0mm²

Cable Outer Dimension
02 = 5.8mm up to 7.0mm
(other diameters are being planned)

00* = Internal Style No. (determined by Yamaichi)

For final part numbers please contact Yamaichi before ordering

NEW



Assembly Process Spring Contact

Step 1

Insert cable to contact.
Close spring to hold cable



Step 2

Insert contact to housing
in the direction of the arrow



Step 3

Tighten screw cap



Specifications

Description	Y-SOL4 F.A.T. / Y-SOL4 C.A.T.
Diameter	Ø 18.8mm
Degree of protection	IP67
Protection class	II
Cable cross section	1.5mm ² to 2.5mm ² and 4.0mm ² to 6.0mm ²
Cable outer diameter	5.8mm to 7.0mm (other dimensions are planned)
Ambient temperature	-40°C to +85°C
Contact resistance	< 5mΩ (typ. value 1mΩ up to 3mΩ)
Voltage rating	1,000 V DC acc. to TÜV EN50521 600 V DC acc. to UL 1703
Current rating	30A (based on 4mm ² cross section)
Extraction force	≥ 89 Newton

TF J-Box for Thin Film Modules

The Y-Sol® Thin Film J-Box can be easily assembled either manually or in an automatic assembly process. Contacting to the PV module is realised by spring loaded contacts in the J-Box lid. One bypass diode can be integrated optionally as per customer requirements. 100% controlled quality by Yamaichi.



Junction Boxes

TF J-Box

Special Features

- ✓ Spring loaded contacts
- ✓ Double sided adhesive

Customer Advantages

- ✓ No tools required
- ✓ Easy and safe contact assembly
- ✓ Simple mounting to module



Certified: acc. to EN50521 (TÜV)
acc. to UL 1703

Part Number (example) and various combinations

Y-SOL4B TFL 1 2 1U M06 F08 GM*

Series No.
for Overmolded
(Hermetic Sealed)

TFS = Short Type
TFL = Long Type

0 = No Bypass Diode
1 = With Bypass Diode

Two Spring Contacts

Cable Cross Section
1U = 1.5mm², with TÜV and UL
2U = 2.5mm², with TÜV and UL

M06 = Male Cable (e.g. 06 = 0.6 meter)

F08 = Female Cable (e.g. 08 = 0.8 meter)

GM* = Internal Style No. (determined by Yamaichi)

For final part numbers please contact Yamaichi before ordering

Specifications

Description	TF J-Box
Dimensions (L x W x H) in mm	Short Type: 60 x 70 x 12 Long Type: 68 x 70 x 12
Degree of protection	IP65
Protection class	II
Number of diodes	Optional with one bypass diode
Number of ribbons	2
Ribbon width	max. 10mm
Conductor cross section	1.5mm ² and 2.5mm ²
Voltage rating	1,000 V DC acc. to TÜV EN50521 600 V DC acc. to UL 1703
Current rating	up to 7A depending on J-Box configuration

Universal J-Box for Silicon Wafer Modules

Featuring SMD diode technology, the Y-Sol[®] Universal J-Box shows approx. 40% less heat development compared to J-Boxes with conventional radial diodes. Automated assembly in an assembly line is possible, either by spring or soldering connection. It is one of the flattest Silicon Wafer J-Boxes on the market (<27mm height) and features integrated cable holders. 100% controlled quality by Yamaichi.



Universal J-Box

Special Feature

- ✓ SMD Diode

Customer Advantages

- ✓ In case of a short-cut there is 40% less heat in the PV junction box
- ✓ This means more safety in operation

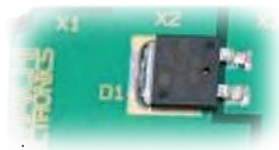

Certified:
acc. to EN50521 (TÜV)

Part Number (example) and various combinations

Y-SOL4B SI 3 4 C 1 4T M10 F8 GM*

Series No.
Y-SOL3B with Y-Sol3
Y-SOL4B with Y-Sol4

Si Wafer J-Box

Number of Bypass Diodes
(3 is standard)

Number of Contacts/Rails

C = Clamped Contacts
S = Solder Contacts

1 = PCB Standard Type
2 = Non Ribbon Crossing Type

Cable Cross Section
4T = 4.0mm², with TÜV 6T = 6.0mm², with TÜV

M10 = Male Cable overall Length (e.g. 10 = 1 meter)

F8 = Female Cable overall Length (e.g. 8 = 0.8 meter)

GM* = Internal Style No. (determined by Yamaichi)

For final part numbers please contact Yamaichi before ordering

Specifications

Description	Universal J-Box
Dimensions (LxWxH)	111 x 140 x 26.5
Degree of protection	IP67
Protection class	II
Number of diodes	Optional with up to 6 bypass diodes
Number of ribbons	2 - 8
Ribbon width	max. 7.5mm
Conductor cross section	4.0mm ² and 6.0mm ²
Voltage rating	1,000 V DC acc. to TÜV EN50521
Current rating	up to 20A depending on J-Box configuration

The Eco-Si Junction Box



Reduced to the Optimum
Yamaichi Eco-Si J-Box for Silicon Wafer Modules

- ✓ Mechanical Rating: IP67
- ✓ Number of Diodes: up to 3 bypass diodes
- ✓ Number of Ribbons: up to 4
- ✓ Voltage Rating: 1,000V DC
- ✓ Current Rating: 12A
- ✓ For welding or soldering connection
- ✓ Ready equipped with Y-Sol3 or Y-Sol4 connector

The cost effective solution for Silicon Wafer Modules with up to 3 bypass diodes

The Intelligent Junction Box



Silicon is a Semiconductor. It is conductive under light. It becomes non conductive when shadowed. In the case of partial shadowing on a PV panel, the affected cell area must be controlled by the Junction Box

- ✓ Intelligent System Power Control on module level
- ✓ Wireless Communication
- ✓ Power Organisation by a transistor controlled J-Box with Maximum Power Point (MPP) tracking on module level
- ✓ Monitoring and Control

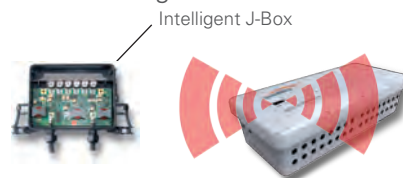

PV panel performance data send to Active Combiner

Wireless Active Combiner sends on data to PC



Monitoring and Control using a PC environment for isolating problems

For further information please contact Yamaichi

YAMAICHI ELECTRONICS USA Inc.
475 Holger Way
San Jose, CA 95134

Sales Office
Tel: 1-408-715-9100
Fax: 1-408-715-9199

e-mail: info@yeu.com
Internet: www.yeu.com

YAMAICHI ELECTRONICS
Deutschland GmbH
Karl-Schmid-Str. 9
81829 Munich
Germany

Tel.: +49 (0) 89 45 10 9 - 0
Fax: +49 (0) 89 45 10 9 - 110
e-mail: sales@yamaichi.de
Internet: www.yamaichi.eu



Компания «ЭлектроПласт» предлагает заключение долгосрочных отношений при поставках импортных электронных компонентов на взаимовыгодных условиях!

Наши преимущества:

- Оперативные поставки широкого спектра электронных компонентов отечественного и импортного производства напрямую от производителей и с крупнейших мировых складов;
- Поставка более 17-ти миллионов наименований электронных компонентов;
- Поставка сложных, дефицитных, либо снятых с производства позиций;
- Оперативные сроки поставки под заказ (от 5 рабочих дней);
- Экспресс доставка в любую точку России;
- Техническая поддержка проекта, помощь в подборе аналогов, поставка прототипов;
- Система менеджмента качества сертифицирована по Международному стандарту ISO 9001;
- Лицензия ФСБ на осуществление работ с использованием сведений, составляющих государственную тайну;
- Поставка специализированных компонентов (Xilinx, Altera, Analog Devices, Intersil, Interpoint, Microsemi, Aeroflex, Peregrine, Syfer, Eurofarad, Texas Instrument, Miteq, Cobham, E2V, MA-COM, Hittite, Mini-Circuits, General Dynamics и др.);

Помимо этого, одним из направлений компании «ЭлектроПласт» является направление «Источники питания». Мы предлагаем Вам помощь Конструкторского отдела:

- Подбор оптимального решения, техническое обоснование при выборе компонента;
- Подбор аналогов;
- Консультации по применению компонента;
- Поставка образцов и прототипов;
- Техническая поддержка проекта;
- Защита от снятия компонента с производства.



Как с нами связаться

Телефон: 8 (812) 309 58 32 (многоканальный)

Факс: 8 (812) 320-02-42

Электронная почта: org@eplast1.ru

Адрес: 198099, г. Санкт-Петербург, ул. Калинина, дом 2, корпус 4, литера А.