



1 Gbps to 4.25 Gbps Multirate VCSEL Driver with Diagnostic Monitors

MAX3795

General Description

The MAX3795 is a high-speed VCSEL driver for small-form-factor (SFF) and small-form-factor pluggable (SFP) fiber optic transmitters. It contains a bias generator, a laser modulator, and comprehensive safety features. The automatic power control (APC) adjusts the laser bias current to maintain average optical power over changes in temperature and laser properties. The driver accommodates common-cathode and differential configurations.

The MAX3795 operates up to 4.25 Gbps. It can switch up to 15 mA of laser modulation current and source up to 15 mA of bias current. Adjustable temperature compensation is provided to keep the optical extinction ratio within specifications over the operating temperature range. The MAX3795 interfaces with the Dallas DS1856/DS1859 to meet SFF-8472 timing and diagnostic requirements. The MAX3795 accommodates various VCSEL packages, including low-cost TO-46 headers.

The MAX3795 safety circuit detects faults that could cause hazardous light levels and disables the VCSEL output. The safety circuits are compliant with SFF and SFP multisource agreements (MSAs).

The MAX3795 is available in a compact 4 mm × 4 mm, 24-pin thin QFN package and operates over the -40°C to +85°C temperature range. The MAX3795 is pin-for-pin compatible with the MAX3740A and is available in lead-free packages.

Applications

Multirate (1 Gbps to 4.25 Gbps) SFP/SFF Modules
Gigabit Ethernet Optical Transmitters
Fibre-Channel Optical Transmitters

Features

- ◆ Supports All SFF-8472 Digital Diagnostics
- ◆ 3.3V ±10% Single Supply
- ◆ 2mA to 15mA Modulation Current
- ◆ 1mA to 15mA Bias Current
- ◆ 52ps Transition Time
- ◆ 8.4ps Deterministic Jitter
- ◆ Optional Peaking Current to Improve VCSEL Edge Speed
- ◆ Supports Common-Cathode and Differential Configuration
- ◆ Safety Circuits Compliant with SFF and SFP MSAs
- ◆ Pin Compatible to MAX3740A

Ordering Information

PART	TEMP RANGE	PIN-PACKAGE
MAX3795ETG	-40°C to +85°C	24 Thin QFN (4mm x 4mm)
MAX3795ETG+	-40°C to +85°C	24 Thin QFN (4mm x 4mm)

+Denotes lead-free package.

Pin Configuration

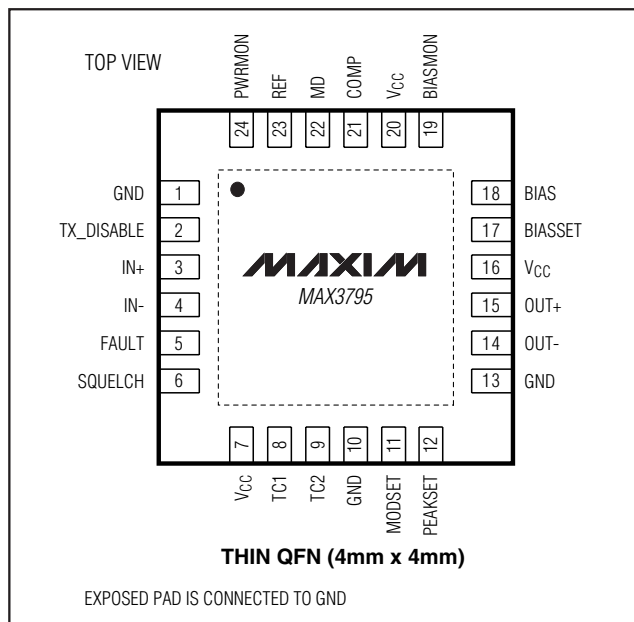

1Gbps to 4.25Gbps Multirate VCSEL Driver with Diagnostic Monitors

ABSOLUTE MAXIMUM RATINGS

Supply Voltage (V _{CC})	-0.5V to +4.0V	Continuous Power Dissipation (T _A = +85°C) 24-Pin Thin QFN (derate 20.8mW/°C above +85°C)	1354mW
Voltage at TX_DISABLE, IN+, IN-, FAULT, SQUELCH, TC1, TC2, MODSET, PEAKSET, BIASET, BIAS, BIASMON, COMP, MD, REF, PWRMON	-0.5V to (V _{CC} + 0.5V)	Storage Temperature Range	-55°C to +150°C
Voltage at OUT+, OUT-	(V _{CC} - 2V) to (V _{CC} + 1V)	Lead Temperature (soldering, 10s)	+300°C
Current into FAULT	-1mA to +25mA		
Current into OUT+, OUT-	60mA		

Stresses beyond those listed under "Absolute Maximum Ratings" may cause permanent damage to the device. These are stress ratings only, and functional operation of the device at these or any other conditions beyond those indicated in the operational sections of the specifications is not implied. Exposure to absolute maximum rating conditions for extended periods may affect device reliability.

ELECTRICAL CHARACTERISTICS

(V_{CC} = +2.97V to +3.63V, T_A = -40°C to +85°C. Typical values are at V_{CC} = +3.3V, TC1 and TC2 are shorted, PEAKSET open, T_A = +25°C, unless otherwise noted.)

PARAMETER	SYMBOL	CONDITIONS	MIN	TYP	MAX	UNITS
Supply Current	I _{CC}	SQUELCH set low, TX_DISABLE set low, peaking is not used (Note 1)	I _{MOD} = 2mA _{P-P}		35	mA
			I _{MOD} = 15mA _{P-P}		71 81	
		Additional current when peaking is used, R _{PEAK} = 1.18kΩ			15	
		Additional current when SQUELCH is high			5 10	
	I _{CC-SHDN}	Total current when TX_DISABLE is high			7	
FAULT OUTPUT						
Output High Voltage	V _{OH}	R _{LOAD} = 10kΩ to 2.97V	2.4			V
Output Low Voltage	V _{OL}	R _{LOAD} = 4.7kΩ to 3.63V			0.4	V
TX_DISABLE INPUT						
Input Impedance	R _{PULL}		4.7	8	10.0	kΩ
Input High Voltage	V _{IH}		2.0			V
Input Low Voltage	V _{IL}				0.8	V
Power-Down Time		The time for I _{CC} to reach I _{CC-SHDN} when TX_DISABLE transitions high		50		μs
SQUELCH						
Squelch Threshold			25		85	mV _{P-P}
Squelch Hysteresis			6			mV _{P-P}
Time to Squelch Data		(Note 3)	0.02		5.00	μs
Time to Resume from Squelch		(Note 3)	0.02		5.00	μs
BIAS GENERATOR						
Maximum Bias Pin Voltage	V _{BIAS-MAX}	Referenced to V _{CC}		-0.65		V
Bias Current	I _{BIAS}	Minimum			1	mA
		Maximum	15			
Accuracy of Programmed Bias Current	ΔBIAS	5mA ≤ I _{BIAS} ≤ 15mA	-8		+8	%
		1mA ≤ I _{BIAS} ≤ 5mA	-12		+12	

1Gbps to 4.25Gbps Multirate VCSEL Driver with Diagnostic Monitors

MAX3795

ELECTRICAL CHARACTERISTICS (continued)

($V_{CC} = +2.97V$ to $+3.63V$, $T_A = -40^{\circ}C$ to $+85^{\circ}C$. Typical values are at $V_{CC} = +3.3V$, TC1 and TC2 are shorted, PEAKSET open, $T_A = +25^{\circ}C$, unless otherwise noted.)

PARAMETER	SYMBOL	CONDITIONS		MIN	TYP	MAX	UNITS
Bias Current During Fault	I _{BIAS_OFF}	Current out of the BIAS pin			1.5	10	μA
BIASMON Gain	G _{BIASMON}	I _{BIASMON} / I _{BIAS}	1mA < I _{BIAS} < 3mA	0.0875	0.105	0.1375	mA/mA
			3mA ≤ I _{BIAS} < 15mA	0.085	0.105	0.125	
BIASMON Stability		(Notes 2, 4)		-10		+10	%
AUTOMATIC POWER CONTROL (APC)							
MD Nominal Voltage	V _{MD}	APC loop is closed		1	V _{REF} - 0.2	2	V
Voltage at REF	V _{REF}			1.2	1.8	2.2	V
MD Voltage During Fault					0		V
MD Input Current		Normal operation (FAULT = low)		-2	0.7	+2	μA
APC Time Constant		C _{COMP} = 0.047μF, ΔI _{PD} / ΔI _{LASER} = 0.02			90		μs
PWRMON Nominal Gain		V _{PWRMON} / (V _{REF} - V _{MD})		1.85	2.15	2.45	V/V
LASER MODULATOR (Load is 50Ω AC-Coupled to OUT+)							
Differential Input Voltage	V _{ID}	Minimum				0.25	V _{P-P}
		Maximum		2.4			
Input Common-Mode Voltage	V _{CM}				1.75		V
Differential Input Resistance	R _{IN}			85	100	115	Ω
Single-Ended Input Return Loss	S ₁₁	f < 4GHz			12.7		dB
Differential Input Return Loss	S _{DD11}	f < 4GHz			11		dB
Modulation Current	I _{MOD}	Current into OUT+ R _{LOAD} ≤ 50Ω	Minimum			2	mA
			Maximum	15			
Laser Modulation During Fault or Squelch Active	I _{MOD_OFF}	DC tested			15	50	μA _{P-P}
Tolerance of Programmed Modulation Current		TC1 is shorted to TC2		-10		+10	%
Minimum Peaking Current		R _{PEAKSET} = 10kΩ			0.2		mA
Maximum Peaking Current		R _{PEAKSET} = 1kΩ			2		mA
Peaking Current Duration					75		ps
Output Resistance	R _{OUT}	Single-ended resistance		42	50	58	Ω
Minimum Programmable Temperature Coefficient					0		ppm/°C
Maximum Programmable Temperature Coefficient		Temperature range 0°C to +70°C			+5000		ppm/°C
Modulation Transition Time (Note 2)	t _R	50Ω load, no peaking, 5mA ≤ I _{MOD} ≤ 15mA	-40°C to +85°C		49	72	ps
			+100°C		58		
	t _F	50Ω load, no peaking, 5mA ≤ I _{MOD} ≤ 15mA	-40°C to +85°C		56	79	
			+100°C		64		

1Gbps to 4.25Gbps Multirate VCSEL Driver with Diagnostic Monitors

ELECTRICAL CHARACTERISTICS (continued)

($V_{CC} = +2.97V$ to $+3.63V$, $T_A = -40^{\circ}C$ to $+85^{\circ}C$. Typical values are at $V_{CC} = +3.3V$, TC1 and TC2 are shorted, PEAKSET open, $T_A = +25^{\circ}C$, unless otherwise noted.)

PARAMETER	SYMBOL	CONDITIONS	MIN	TYP	MAX	UNITS
Deterministic Jitter	DJ	5mA \leq I _{MOD} \leq 15mA, 4.25Gbps, K28.5 (Notes 2, 5)	-40°C to +85°C	8.4	15.6	psp-P
			+100°C	12.7		
Random Jitter	RJ	APC closed loop		0.5		psRMS
		APC open loop (Note 2)		0.5	0.9	
SAFETY FEATURES (see the Typical Operating Characteristics)						
High-Current Fault Threshold	V _{BMTH}	V _{BIASMON} > V _{BMTH} causes a fault	0.7	0.8	0.9	V
V _{BIAS} Fault Threshold	V _{BTH}	V _{BIAS} referenced to V _{CC}	-0.250	-0.2	-0.150	V
Power-Monitor Fault Threshold	V _{PMTH}	V _{PWRMON} > V _{PMTH} causes a fault	0.7	0.8	0.9	V
TX Disable Time	t _{OFF}	Time from rising edge of TX_DISABLE to I _{BIAS} = I _{BIAS_OFF} and I _{MOD} = I _{MOD_OFF} (Note 2)		1.8	5	μ s
TX Disable Negate Time	t _{ON}	Time from rising edge of TX_DISABLE to I _{BIAS} and I _{MOD} at 99% of steady state (Note 2)		55	500	μ s
Fault Reset Time	t _{INIT1}	Time to set V _{FAULT} = low after power-on or after rising edge of TX_DISABLE (Note 2)		60	200	ms
Power-On Time	t _{INIT2}	Time after power-on to transmitter-on with TX_DISABLE low (Note 2)		60	200	ms
Fault Assert Time	t _{FAULT}	Time from fault occurrence to V _{FAULT} = high; C _{FAULT} < 20pF, R _{FAULT} = 4.7k Ω (Note 2)		1.4	50	μ s
Fault Delay Time	t _{FLTDLY}	Time from fault to I _{BIAS} = I _{BIAS_OFF} and I _{MOD} = I _{MOD_OFF} ; measured with a continuously occurring fault (Note 2)		1	5	μ s
TX_DISABLE Reset	t _{RESET}	Time TX_DISABLE must be held high to reset FAULT (Note 2)			1	μ s

Note 1: Supply current measurements exclude I_{BIAS} from the total current.

Note 2: AC characteristics guaranteed by design and characterization.

Note 3: Measured by applying a pattern that contains 20 μ s of K28.5, followed by 5 μ s of zeros, then 20 μ s of K28.5, followed by 5 μ s of ones. Data rate is equal to 2.5Gbps, with inputs filtered using 1.8GHz Bessel filters.

Note 4: Variation of bias monitor gain for any single part over the range of V_{CC}, temperature, 3mA < I_{BIAS} < 15mA.

Note 5: Deterministic jitter measured at 4.25Gbps with a K28.5 pattern (00111110101100000101).

1Gbps to 4.25Gbps Multirate VCSEL Driver with Diagnostic Monitors

Typical Operating Characteristics

($V_{CC} = +3.3V$, $R_{TC} = 0\Omega$, PEAKSET open, measured electrically with a 50Ω load AC-coupled to OUT+, $T_A = +25^\circ C$, unless otherwise noted.)

MAX3795

ELECTRICAL EYE DIAGRAM

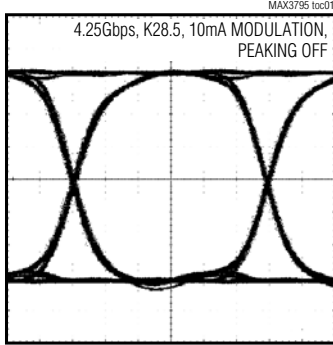

75mV/div

40ps/div

ELECTRICAL EYE DIAGRAM

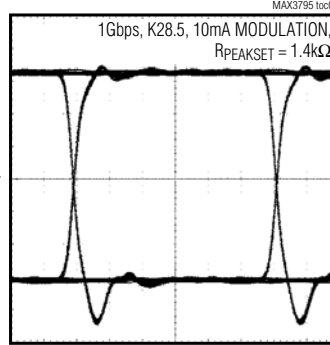

75mV/div

152ps/div

OPTICAL EYE DIAGRAM

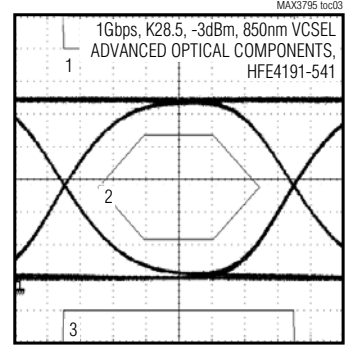

135ps/div

OPTICAL EYE DIAGRAM

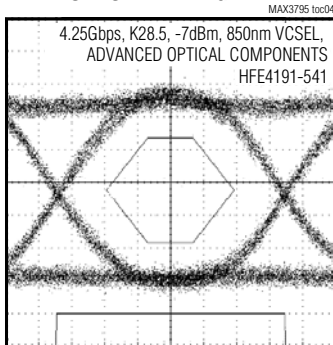

34ps/div

OPTICAL EYE DIAGRAM

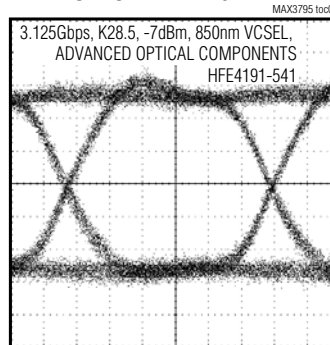

50ps/div

I_{BIAS} vs. BIAS CURRENT

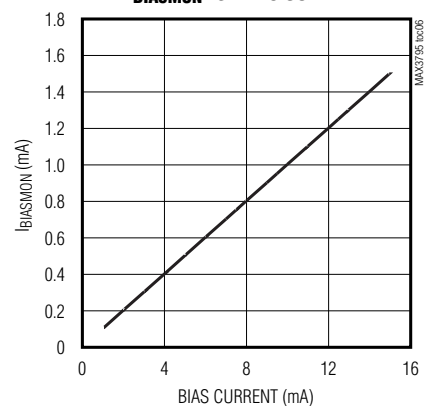

DETERMINISTIC JITTER vs. MODULATION CURRENT

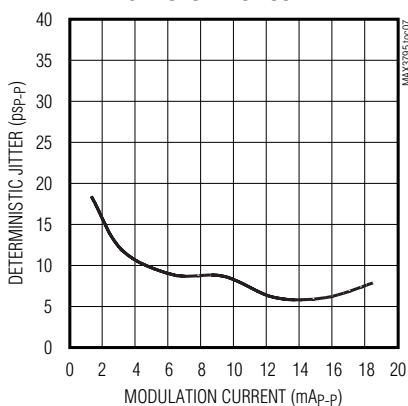

RANDOM JITTER vs. MODULATION CURRENT

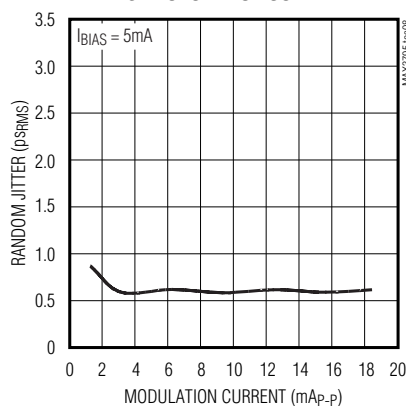

TRANSITION TIME vs. MODULATION CURRENT

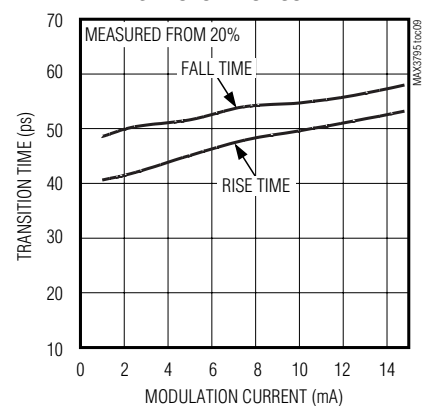

1Gbps to 4.25Gbps Multirate VCSEL Driver with Diagnostic Monitors

Typical Operating Characteristics (continued)

($V_{CC} = +3.3V$, $R_{TC} = 0\Omega$, PEAKSET open, measured electrically with a 50Ω load AC-coupled to OUT+, $T_A = +25^\circ C$, unless otherwise noted.)

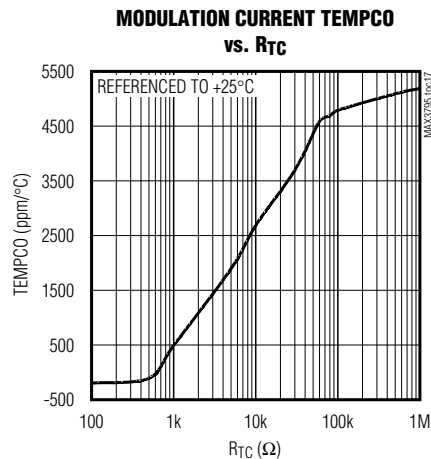
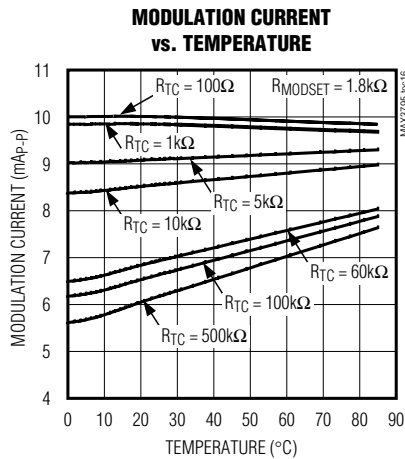
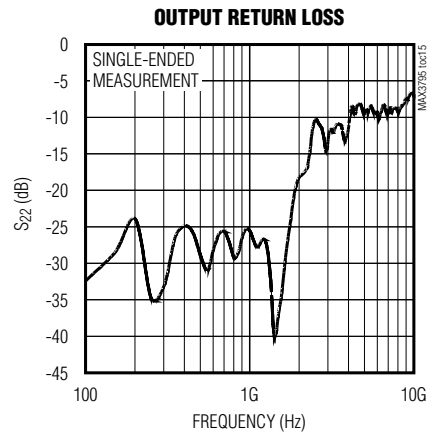
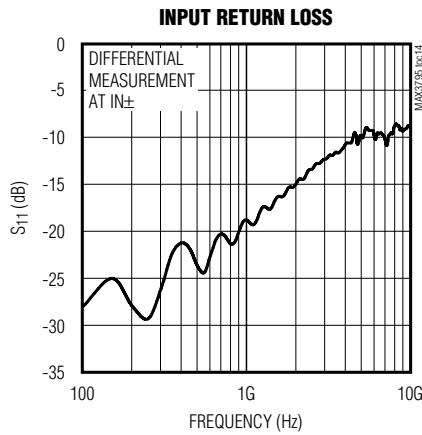
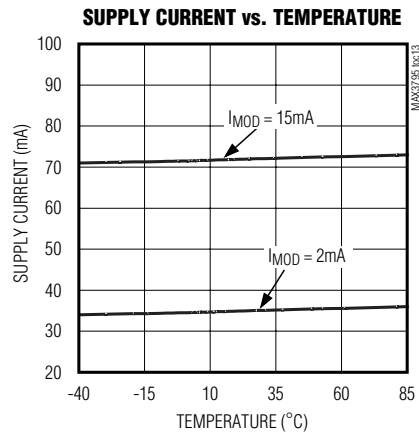
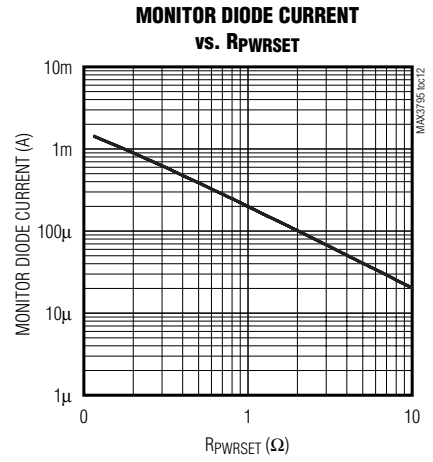
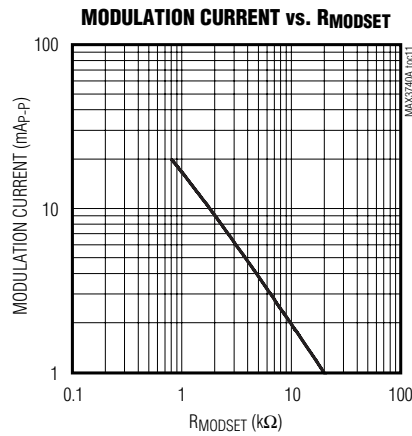
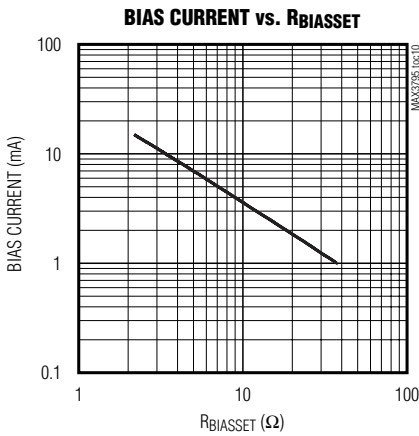

1Gbps to 4.25Gbps Multirate VCSEL Driver with Diagnostic Monitors

MAX3795

Typical Operating Characteristics (continued)

($V_{CC} = +3.3V$, $R_{TC} = 0\Omega$, PEAKSET open, measured electrically with a 50Ω load AC-coupled to OUT+, $T_A = +25^\circ C$, unless otherwise noted.)

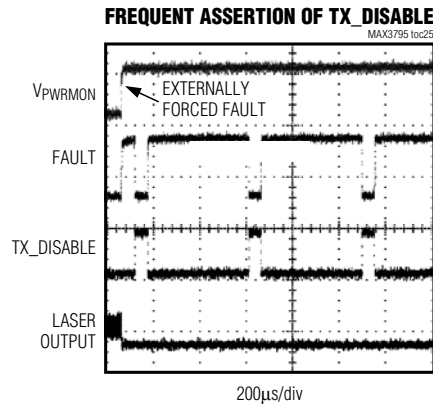
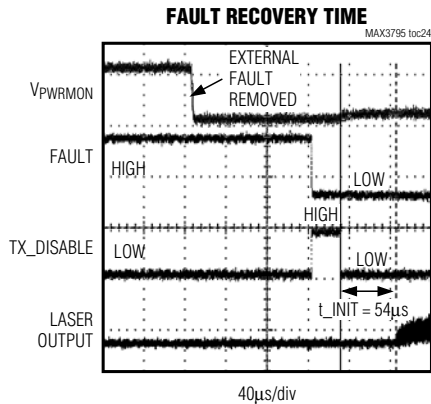
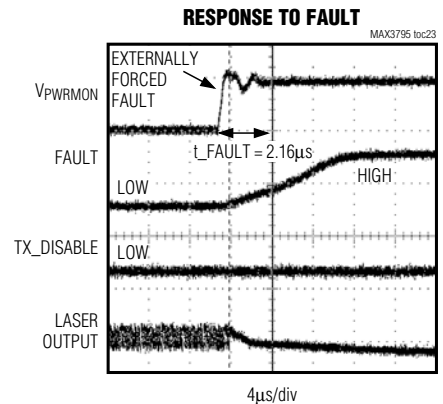
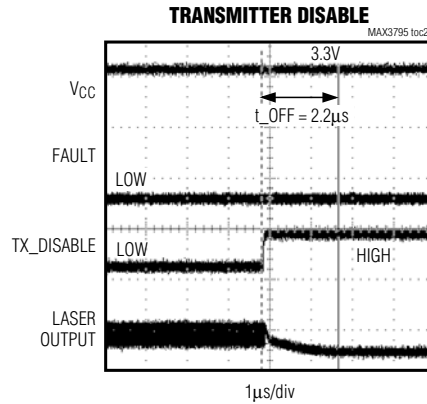
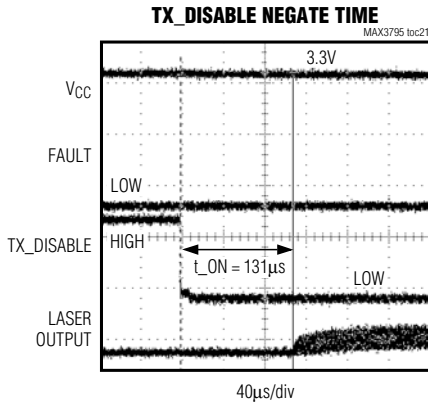
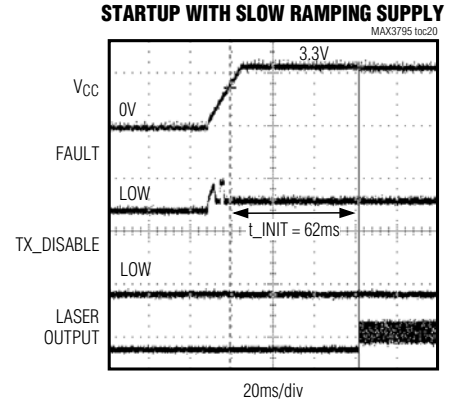
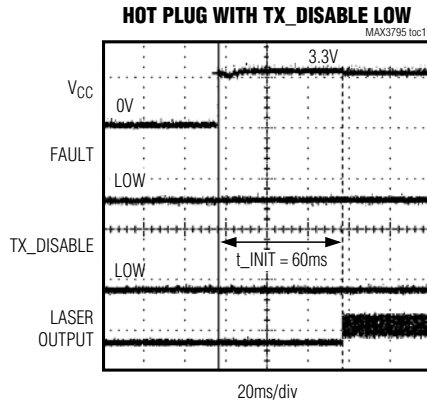
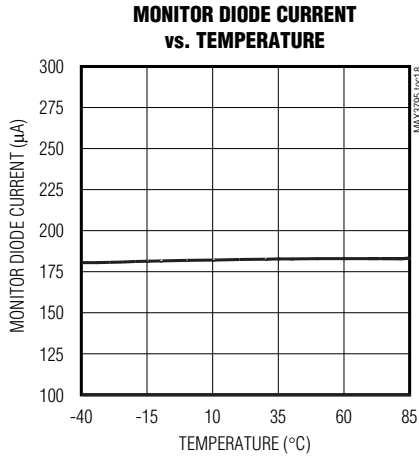

1Gbps to 4.25Gbps Multirate VCSEL Driver with Diagnostic Monitors

Pin Description

PIN	NAME	FUNCTION
1, 10, 13	GND	Ground
2	TX_DISABLE	Transmit Disable. Driver output is disabled when TX_DISABLE is high or left unconnected. The driver output is enabled when the pin is asserted low.
3	IN+	Noninverted Data Input
4	IN-	Inverted Data Input
5	FAULT	Fault Indicator. Open-drain output with ESD protection. FAULT is asserted high during a fault condition.
6	SQUELCH	Squelch Enable. Squelch is enabled when the pin is set high. Squelch is disabled when the pin is set low or left open.
7, 16, 20	VCC	+3.3V Supply Voltage
8	TC1	Temperature Compensation Set Pin 1. A resistor placed between TC1 and TC2 (R_{TC}) programs the temperature coefficient of the laser modulation current.
9	TC2	Temperature Compensation Set Pin 2. A resistor placed between TC1 and TC2 (R_{TC}) programs the temperature coefficient of the laser modulation current.
11	MODSET	Modulation Set. A resistor connected from MODSET to ground (R_{MODSET}) programs the desired modulation current amplitude.
12	PEAKSET	Peaking Current Set. A resistor connected between PEAKSET and ground ($R_{PEAKSET}$) programs the peaking current amplitude. To disable peaking, leave PEAKSET open.
14	OUT-	Inverted Modulation Current Output
15	OUT+	Noninverted Modulation Current Output
17	BIASSET	Bias-Current Set. When a closed-loop configuration is used, connect a 1.7k Ω resistor between ground and BIASSET to program the maximum bias current. When an open configuration is used, connect a resistor between BIASSET and ground ($R_{BIASSET}$) to program the VCSEL bias current.
18	BIAS	Bias-Current Output
19	BIASMON	Bias-Current Monitor. The output of BIASMON is a sourced current proportional to the bias current. A resistor connected between BIASMON and ground ($R_{BIASMON}$) can be used to form a ground-referenced bias monitor.
21	COMP	Compensation Pin. A capacitor between COMP and MD compensates the APC. A typical value of 0.047 μ F is recommended. For open-loop configuration, short the COMP pin to GND to deactivate the APC circuit.
22	MD	Monitor Diode Connection
23	REF	Reference Pin. Reference monitor used for APC. A resistor between REF and MD (R_{PWRSET}) programs the photomonitor current when the APC loop is closed.
24	PWRMON	Average Power Monitor. The pin is used to monitor the transmit optical power. For open-loop configuration, connect PWRMON to GND.
EP	Exposed Pad	Ground. Must be soldered to the circuit board ground for proper thermal and electrical performance. See the <i>Layout Considerations</i> section.

1 Gbps to 4.25 Gbps Multirate VCSEL Driver with Diagnostic Monitors

MAX3795

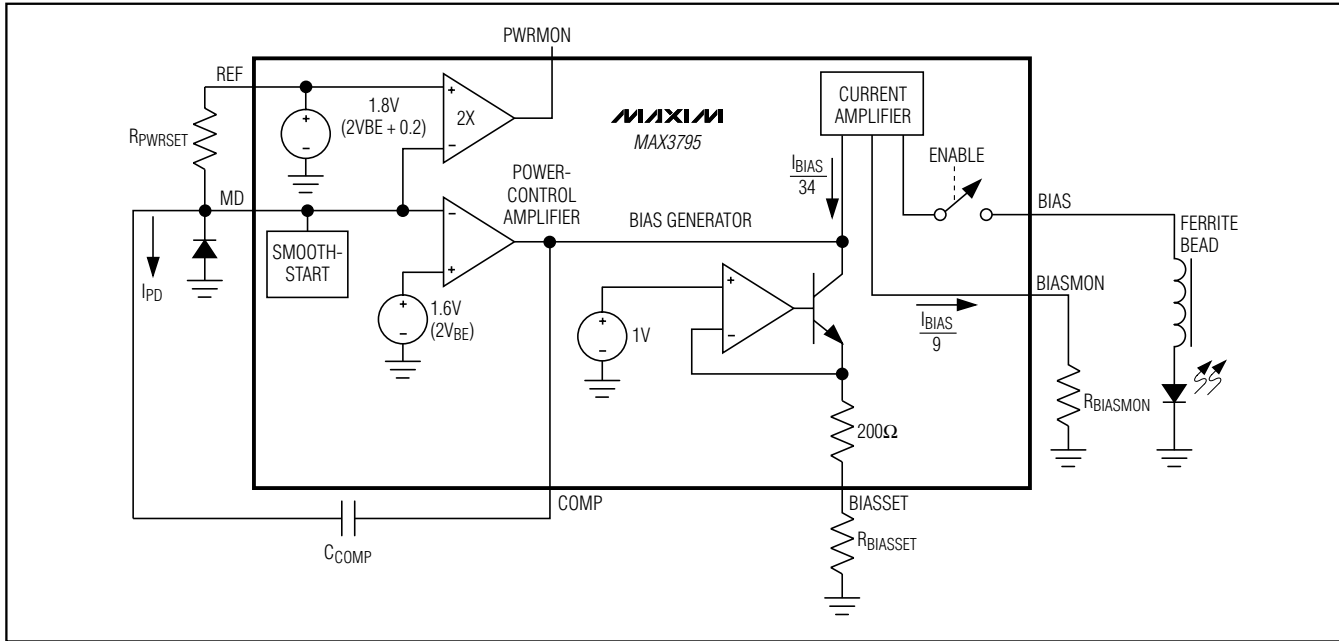

Figure 1. Bias Generator

Detailed Description

The MAX3795 contains a bias generator with APC, safety circuit, and a laser modulator with optional peaking compensation (see the *Functional Diagram*).

Bias Generator

Figure 1 shows the bias-generator circuitry that contains a power-control amplifier and smooth-start circuitry. An internal pnp transistor provides DC laser current to bias the laser in a light-emitting state. The APC circuitry adjusts the laser-bias current to maintain average power over temperature and changing laser properties. The smooth-start circuitry prevents current spikes to the laser during power-up or enable, ensuring compliance with safety requirements and extending the life of the laser.

The MD input is connected to the cathode of a monitor diode, which is used to sense laser power. The BIAS output is connected to the anode of the laser through an inductor or ferrite bead. The power-control amplifier drives a current amplifier to control the laser's bias current. During a fault condition, the bias current is disabled.

The PWRMON output provides a voltage proportional to average laser power given by:

$$V_{PWRMON} = 2 \times I_{PD} \times R_{PWRSET}$$

where $V_{PWRMON} = 0.4V$ (typ)

The BIASMON output provides a current proportional to the laser bias current given by:

$$I_{BIASMON} = I_{BIAS} \times G_{BIASMON}$$

When APC is not used (no monitor diode), connect the COMP and PWRMON pins to GND. In this mode, bias current is set by the resistor ($R_{BIASSET}$) between the BIASSET pin and GND. When a closed-loop configuration is used, connect a 1.7k Ω resistor between ground and BIASSET to set the maximum bias current.

Safety Circuit

The safety circuit contains an input disable (TX_DISABLE), a latched fault output (FAULT), and fault detectors (Figure 2). This circuit monitors the operation of the laser driver and forces a shutdown (disables laser) if a fault is detected (Table 1). Table 2 contains the circuit's response to various single-point failures. The transmit fault condition is latched until reset by a toggle of TX_DISABLE or V_{CC}. The FAULT pin should be pulled high with a 4.7k Ω to 10k Ω resistor.

Table 1. Fault Conditions

PIN	FAULT CONDITION
BIAS	$V_{BIAS} > V_{CC} - 0.2V$
BIASMON	$V_{BIASMON} > 0.8V$
PWRMON	$V_{PWRMON} > 0.8V$

1Gbps to 4.25Gbps Multirate VCSEL Driver with Diagnostic Monitors

Table 2. Circuit Response to Various Single-Point Faults (Closed-Loop APC Configuration)

PIN NAME	CIRCUIT RESPONSE TO V _{CC} SHORT	CIRCUIT RESPONSE TO GND SHORT	CIRCUIT RESPONSE TO OPEN
FAULT	Does not affect laser power.	Does not affect laser power.	Does not affect laser power.
TX_DISABLE	Modulation and bias current are disabled.	Normal condition for circuit operation.	Modulation and bias current are disabled.
IN+	Does not affect laser power.	Does not affect laser power.	Does not affect laser power.
IN-	Does not affect laser power.	Does not affect laser power.	Does not affect laser power.
SQUELCH	Does not affect laser power.	Does not affect laser power.	Does not affect laser power.
TC1	Does not affect laser power.	Does not affect laser power.	The laser modulation is decreased, but average power is not affected.
TC2	The laser modulation is increased, but average power is not affected.	Modulation current is disabled.	The laser modulation is decreased, but average power is not affected.
MODSET	Modulation current is disabled.	The laser modulation is increased, but average power is not affected.	The laser modulation is decreased, but average power is not affected.
PEAKSET	Does not affect laser power.	Does not affect laser power.	Does not affect laser power.
OUT+	Modulation current is disabled.	Modulation current is disabled.	Modulation current is disabled.
OUT-	Does not affect laser power.	Does not affect laser power.	Does not affect laser power.
BIASSET	Laser bias is disabled.	Fault state* occurs.	Laser bias is disabled.
BIAS	Fault state* occurs. Note that VCSEL emissions may continue. Care must be taken to prevent this condition.	This disables the VCSEL.	This disables the VCSEL.
BIASMON	Fault state* occurs.	Does not affect laser power.	Fault state* occurs.
COMP	The bias current is reduced, and the average power of the laser output is reduced.	I _{BIAS} increases to the value determined by R _{BIASSET} . If the bias-monitor fault threshold is exceeded, a fault is signaled.	APC loop will be unstable. If the bias-monitor fault threshold is exceeded, a fault is signaled.
MD	I _{BIAS} increases to the value determined by R _{BIASSET} . If the bias-monitor fault threshold is exceeded, a fault is signaled.	The bias current is reduced, and the average power of the laser output is reduced.	I _{BIAS} increases to the value determined by R _{BIASSET} . If the bias monitor fault threshold is exceeded, a fault is signaled.
REF	I _{BIAS} increases to the value determined by R _{BIASSET} . If the bias-monitor fault threshold is exceeded, a fault is signaled.	The bias current is reduced, and the average power of the laser output is reduced.	The bias current is reduced, and the average power of the laser output is reduced.
PWRMON	Fault state* occurs.	Does not affect laser power.	Does not affect laser power.

*A fault state asserts the FAULT pin, disables the modulator output, and disables the bias output.

Modulation Circuit

The modulation circuitry consists of an input buffer, a current mirror, and a high-speed current switch (Figure 3). The modulator drives up to 15mA of modulation into a 50Ω VCSEL load.

The amplitude of the modulation current is set with resistors at MODSET and temperature coefficient (TC1, TC2) pins. The resistor at MODSET (R_{MODSET}) programs the temperature-stable portion of the modulation current, and the resistor between TC1 and TC2 (R_{TC}) programs the temperature coefficient of the modulation

1Gbps to 4.25Gbps Multirate VCSEL Driver with Diagnostic Monitors

MAX3795

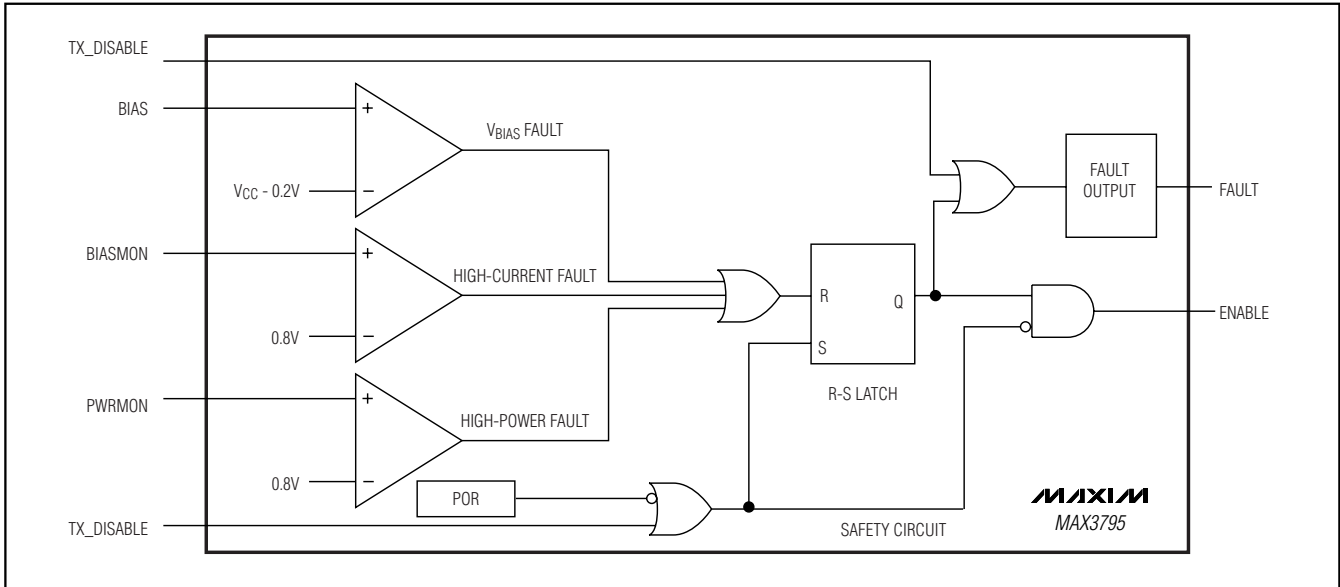

Figure 2. Safety Circuit

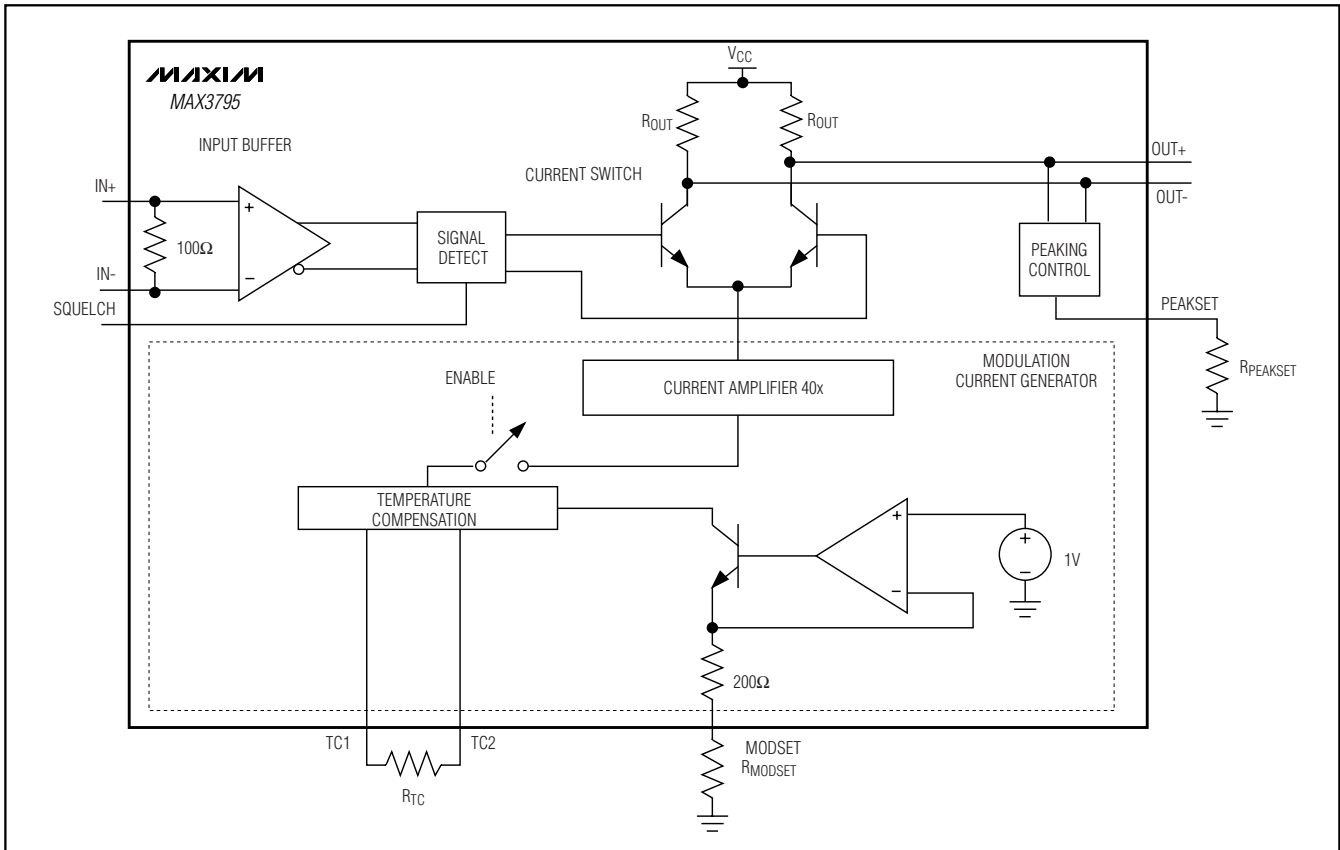

Figure 3. Modulation Circuit

1Gbps to 4.25Gbps Multirate VCSEL Driver with Diagnostic Monitors

current. For appropriate R_{TC} and R_{MODSET} values, see the *Typical Operating Characteristics*.

Design Procedure

Select Laser

Select a communications-grade laser with a rise time of 90ps or better for 4.25Gbps applications. Use a high-efficiency laser that requires low modulation current and generates a low-voltage swing. Trim the leads to reduce laser package inductance. The typical package leads have inductance of 25nH per inch (1nH/mm). This inductance causes a large voltage swing across the laser. A compensation filter network can also be used to reduce ringing, edge speed, and voltage swing.

Programming Modulation Current

A resistor (R_{MODSET}) placed between the MODSET pin and ground controls the modulation current out of the MAX3795 to the VCSEL. The modulation current is given by the following:

$$I_{MOD} = \left[\left(\frac{1}{200 + R_{MODSET}} \right) \times 40 \right] \times \left[\frac{R_{OUT}}{R_{OUT} + R_{LOAD}} \right]$$

It is important to note that the load impedance of the VCSEL affects the modulation current being sourced by the MAX3795. The Modulation Current vs. R_{MODSET} graph in the *Typical Operating Characteristics* shows the current into a 50 Ω load. Capacitance at the MODSET pin should be ≤ 20 pF.

Programming Bias Current

The bias current output of the MAX3795 is controlled by a resistor ($R_{BIASSET}$) placed between the BIASSET pin and ground. In open-loop operation, BIASSET controls the bias current level of the VCSEL. In closed-loop operation (APC); the $R_{BIASSET}$ controls the maximum allowed bias current. The open-loop bias current is given by the following:

$$I_{BIAS} = \left(\frac{1.2}{200 + R_{BIASSET}} \right) \times 34$$

The Bias Current vs. $R_{BIASSET}$ graph in the *Typical Operating Characteristics* shows the current into a 50 Ω load. Capacitance at the BIASSET pin should be ≤ 20 pF.

Programming Modulation-Current Tempco

Compute the required modulation tempco from the slope efficiency of the laser at $T_A = +25^\circ\text{C}$ and at a higher temperature. Then select the value of R_{TC} from the *Typical Operating Characteristics*. For example, suppose a laser has a slope efficiency (SE) of 0.021mW/mA at $+25^\circ\text{C}$, which reduces to 0.018mW/mA at $+85^\circ\text{C}$. The temperature coefficient is given by the following:

$$\begin{aligned} \text{Laser tempco} &= \frac{(SE_{85} - SE_{25})}{SE_{25} \times (85 - 25)} \times 10^6 \\ &= -2380 \text{ppm}/^\circ\text{C} \end{aligned}$$

From the *Typical Operating Characteristics*, the value of R_{TC} , which offsets the tempco of the laser, is 9k Ω . If modulation temperature compensation is not desired, short TC1 and TC2.

Programming the APC Loop

Program the average optical power by adjusting RPWRSET. To select the resistance, determine the desired monitor current to be maintained over temperature and lifetime. See the Monitor Diode Current vs. RPWRSET graph in the *Typical Operating Characteristics*, and select the value of RPWRSET that corresponds to the required current.

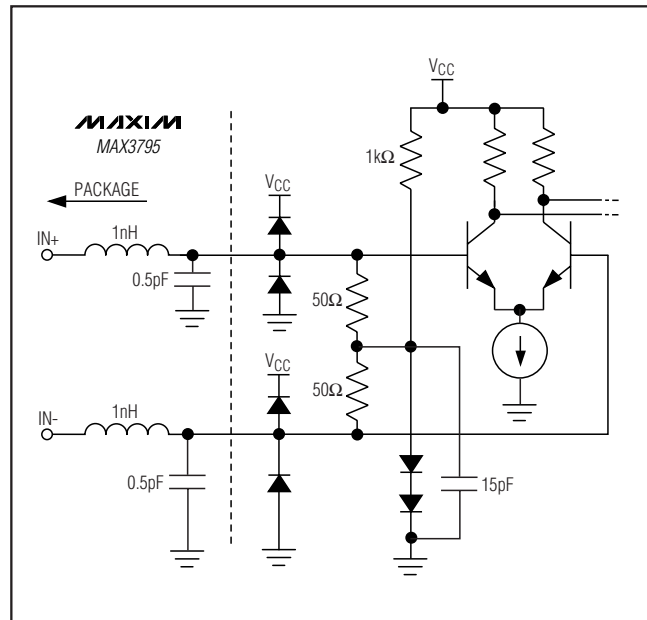

Figure 4. Simplified Input Structure

1Gbps to 4.25Gbps Multirate VCSEL Driver with Diagnostic Monitors

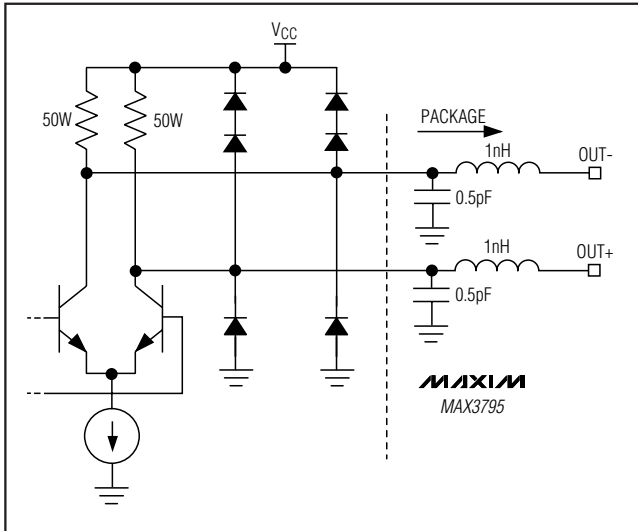

Figure 5. Simplified Output Structure

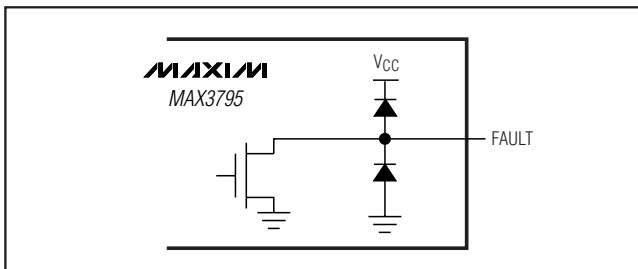

Figure 6. Fault Circuit Interface

$$I_{PD} = \frac{V_{REF} - V_{MD}}{R_{PWRSET}} \approx \frac{0.2V}{R_{PWRSET}}$$

The low frequency cutoff of a transmitter using APC is given by:

$$f_{3dB} \approx \frac{\Delta I_{PD}}{\Delta I_{LASER}} \times \frac{1}{2 \times \pi \times C_{APC} \times 50}$$

Input Termination Requirements

The MAX3795 data inputs are SFP MSA compatible. On-chip, 100Ω differential input impedance is provided for optimal termination (Figure 4). Because of the on-chip biasing network, the MAX3795 inputs self-bias to the proper operating point to accommodate AC-coupling.

Applications Information

Interface Models

Figures 4 and 5 show simplified input and output circuits for the MAX3795 laser driver. Figure 6 shows the fault circuit interface.

Layout Considerations

To minimize inductance, keep the connections between the MAX3795 output pins and laser diode as short as possible. Use multilayer boards with uninterrupted ground planes to minimize EMI and crosstalk.

Exposed-Pad (EP) Package

The exposed pad on the 24-pin thin QFN provides a very low thermal resistance path for heat removal from the IC. The pad is also electrical ground on the MAX3795 and must be soldered to the circuit board ground for proper thermal and electrical performance. Refer to Maxim Application Note HFAN-08.1: *Thermal Considerations for QFN and Other Exposed-Pad Packages* for additional information.

Laser Safety and IEC 825

The International Electrotechnical Commission (IEC) determines standards for hazardous light emissions from fiber-optic transmitters. IEC 825 defines the maximum light output for various hazard levels. The MAX3795 provides features that facilitate compliance with IEC 825. A common safety precaution is single-point fault tolerance, whereby one unplanned short, open, or resistive connection does not cause excess light output. Using this laser driver alone does not ensure that a transmitter design is compliant with IEC 825. The entire transmitter circuit and component selections must be considered. Customers must determine the level of fault tolerance required by their applications, recognizing that Maxim products are not designed or authorized for use as components in systems intended for surgical implant into the body, for applications intended to support or sustain life, or for any other application where the failure of a Maxim product could create a situation where personal injury or death may occur.

1Gbps to 4.25Gbps Multirate VCSEL Driver with Diagnostic Monitors

Functional Diagram

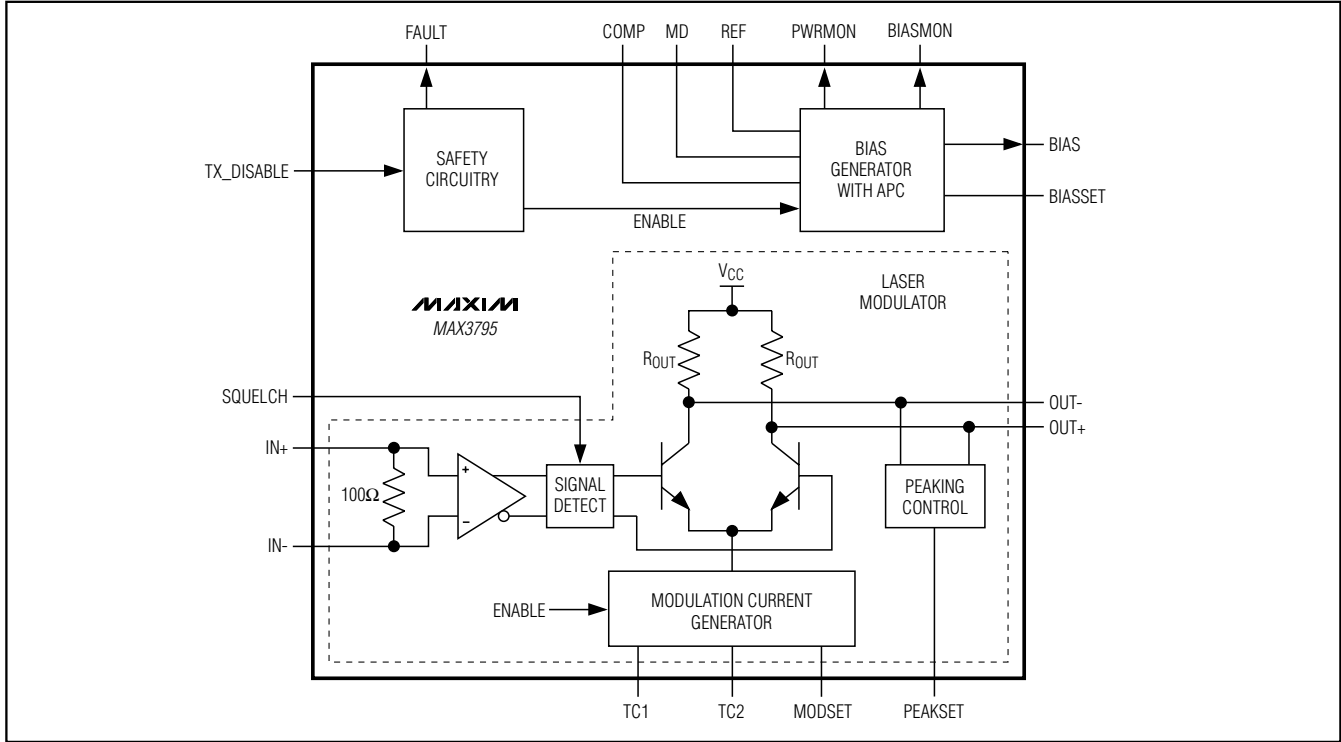

Chip Information

TRANSISTOR COUNT: 3806
 PROCESS: SiGe BIPOLAR

Package Information

For the latest package outline information, go to www.maxim-ic.com/packages.

PART	PACKAGE TYPE	PACKAGE CODE
MAX3795ETG	24 Thin QFN (4mm x 4mm x 0.8mm)	T2444-1
MAX3795ETG+	24 Thin QFN (4mm x 4mm x 0.8mm)	T2444-1

1 Gbps to 4.25 Gbps Multirate VCSEL Driver with Diagnostic Monitors

Typical Application Circuit

MAX3795

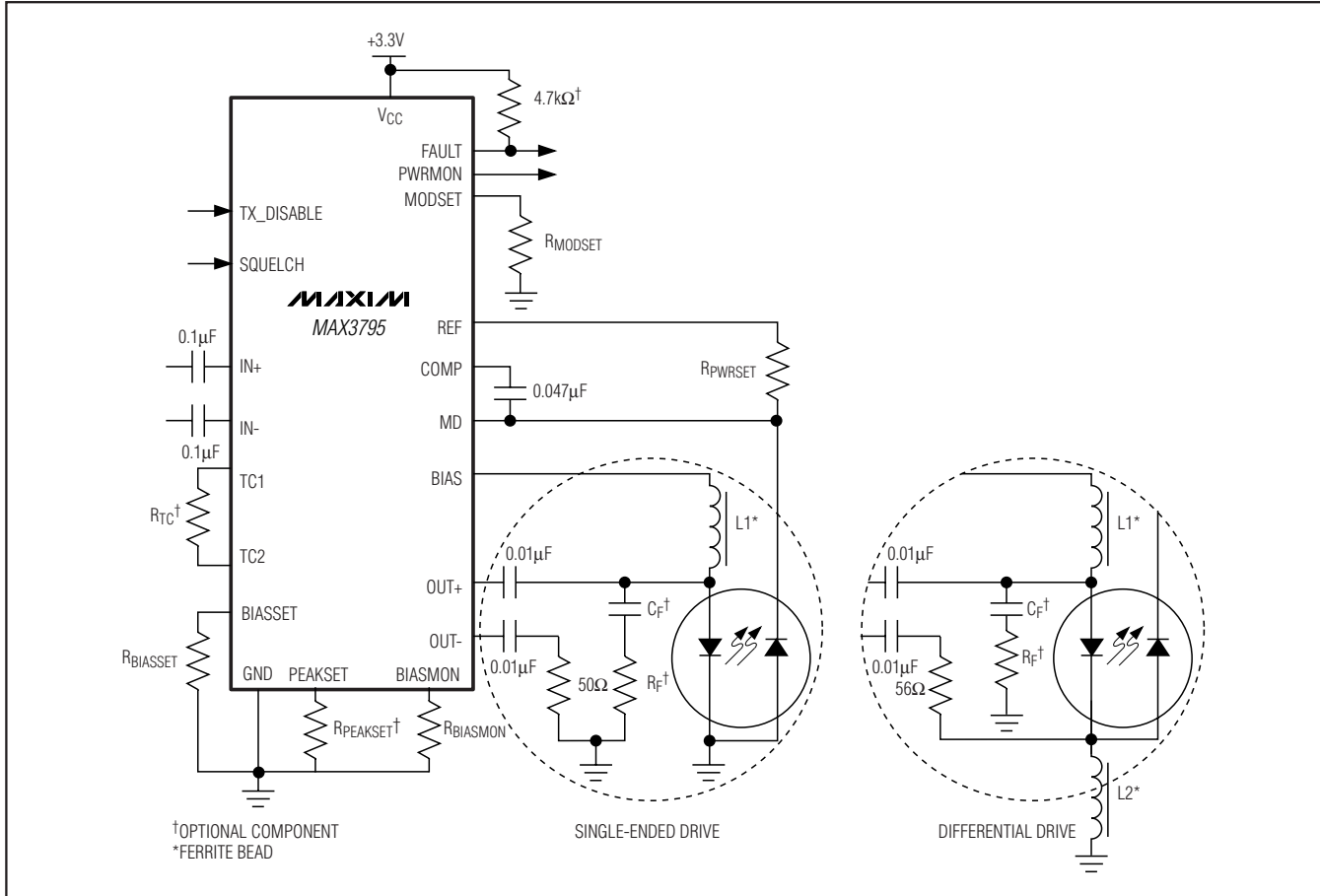

Maxim cannot assume responsibility for use of any circuitry other than circuitry entirely embodied in a Maxim product. No circuit patent licenses are implied. Maxim reserves the right to change the circuitry and specifications without notice at any time.

Maxim Integrated Products, 120 San Gabriel Drive, Sunnyvale, CA 94086 408-737-7600 15



Компания «ЭлектроПласт» предлагает заключение долгосрочных отношений при поставках импортных электронных компонентов на взаимовыгодных условиях!

Наши преимущества:

- Оперативные поставки широкого спектра электронных компонентов отечественного и импортного производства напрямую от производителей и с крупнейших мировых складов;
- Поставка более 17-ти миллионов наименований электронных компонентов;
- Поставка сложных, дефицитных, либо снятых с производства позиций;
- Оперативные сроки поставки под заказ (от 5 рабочих дней);
- Экспресс доставка в любую точку России;
- Техническая поддержка проекта, помощь в подборе аналогов, поставка прототипов;
- Система менеджмента качества сертифицирована по Международному стандарту ISO 9001;
- Лицензия ФСБ на осуществление работ с использованием сведений, составляющих государственную тайну;
- Поставка специализированных компонентов (Xilinx, Altera, Analog Devices, Intersil, Interpoint, Microsemi, Aeroflex, Peregrine, Syfer, Eurofarad, Texas Instrument, Miteq, Cobham, E2V, MA-COM, Hittite, Mini-Circuits, General Dynamics и др.);

Помимо этого, одним из направлений компании «ЭлектроПласт» является направление «Источники питания». Мы предлагаем Вам помощь Конструкторского отдела:

- Подбор оптимального решения, техническое обоснование при выборе компонента;
- Подбор аналогов;
- Консультации по применению компонента;
- Поставка образцов и прототипов;
- Техническая поддержка проекта;
- Защита от снятия компонента с производства.



Как с нами связаться

Телефон: 8 (812) 309 58 32 (многоканальный)

Факс: 8 (812) 320-02-42

Электронная почта: org@eplast1.ru

Адрес: 198099, г. Санкт-Петербург, ул. Калинина, дом 2, корпус 4, литера А.