

## Free Standing Connector Mounted Card Guides

Secure connection, rugged support of 0.062" thick PCB's when space is limited. P/N BR27D is die cast of zinc alloy#3 (ASTM B240-06). Other sizes are 6063 T5 aluminum alloy. All sizes include HD55 hardware kit to attach connector to board. Connector not included (See Page 70). All sold as a pair and are fully RoHS compliant.

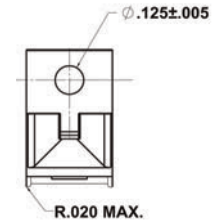
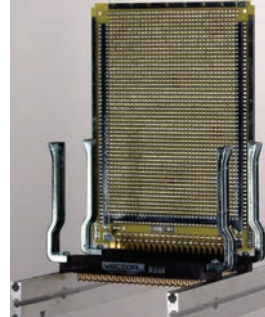

Part No.	Use With Connector	For Use With	Material
BR27D	R644, R644-2, R644-3C, R644-3F	4.5"W (3677, 3682 & 3662 series), Page 57	Zinc #3
BR27-1	R636-1, R636-2	4.5"W (3719 series), Page 58	Al Alloy 6063 T5
BR27-3	R630	2.73"W (3797 series), Page 56	Al Alloy 6063 T5
BR27-5	R656-1, R656-2	4.5"W (4610 series), Page 63	Al Alloy 6063 T5

BR27D Zinc die-cast model shown

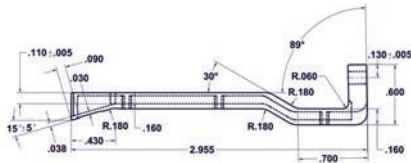

8 7 6 5 4 3 2 1

REVISIONS				
ZONE	REV.	DESCRIPTION	DATE	APPROVED
ALL	F		01/08/09	

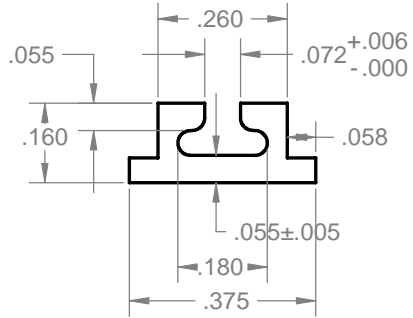

SECTION K-K  
SCALE 4:1

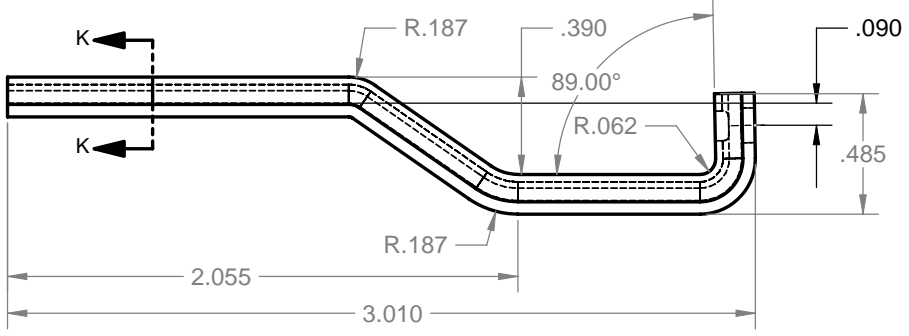
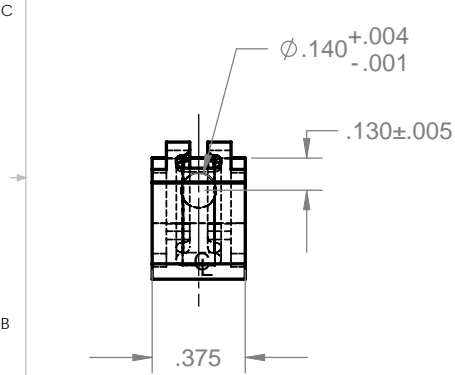
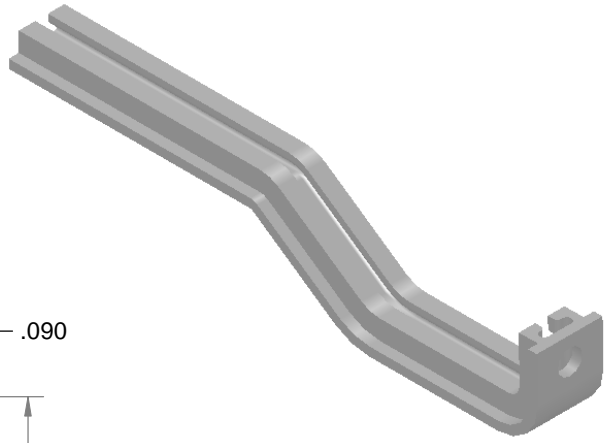
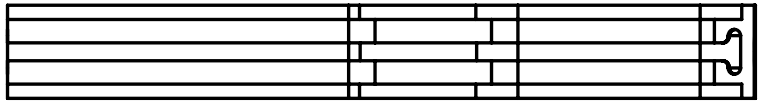

- 4. PARTS TO BE DEGREASED AFTER FABRICATION
- 3. PARTS TO BE FREE OF EXCESSIVE BURRS AND SURFACE SCRATCHES
- 2. FINISH: CLEAR ANODIZE
- 1. MATERIAL: ALUM. EXTRUSION 6063-T5

NOTES: UNLESS OTHERWISE SPECIFIED.

**PROPRIETARY AND CONFIDENTIAL**  
THE INFORMATION CONTAINED IN THIS DRAWING IS THE SOLE PROPERTY OF VECTOR ELECTRONICS & TECH., INC. ANY REPRODUCTION IN PART OR AS A WHOLE WITHOUT THE WRITTEN PERMISSION OF VECTOR ELECTRONICS & TECH., INC. IS PROHIBITED.

UNLESS OTHERWISE SPECIFIED:		NAME	DATE	<b>VECTOR</b> ELECTRONICS & TECHNOLOGY, INC. CA 91605	11115 VANOWEN ST., NORTH HOLLYWOOD, CA 91605	
DIMENSIONS ARE IN INCHES TOLERANCES: FRACTIONAL ± ANGULAR: ±5° TWO PLACE DECIMAL ±.03 THREE PLACE DECIMAL ±.010 INTERPRET GEOMETRIC TOLERANCING PER:		DRAWN	TRUSHAR		01/08/09	<b>CARD GUIDE</b> BR27-3
MATERIAL <b>1</b>		CHECKED				
FINISH <b>2</b>		ENG APPR.				
DO NOT SCALE DRAWING		MFG APPR.				
		Q.A.			SIZE DWG. NO.	
		THIRD ANGLE PROJECTION			REV	
					B M5474-1-8 F	
					SCALE: 1:1 WEIGHT: SHEET 1 OF 1	

8 7 6 5 4 3 2 1

8 7 6 5 4 3 2 1

REVISIONS				
ZONE	REV.	DESCRIPTION	DATE	APPROVED
ALL	F		01/08/09	

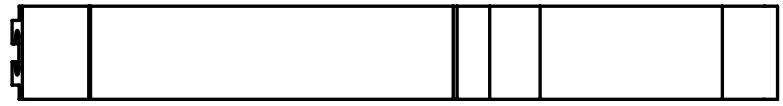
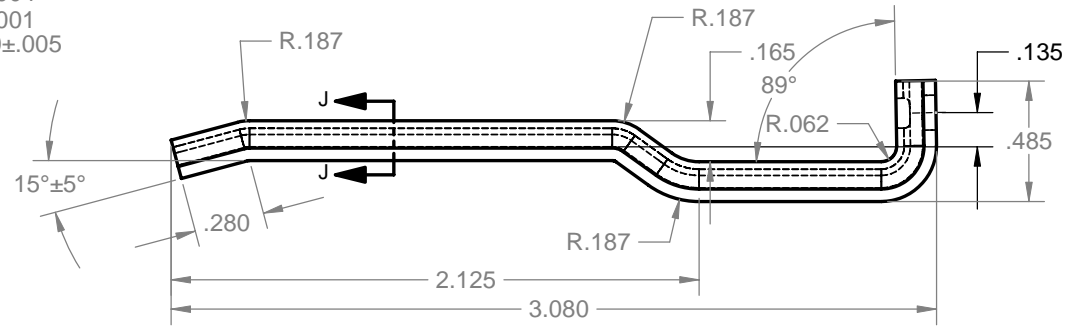
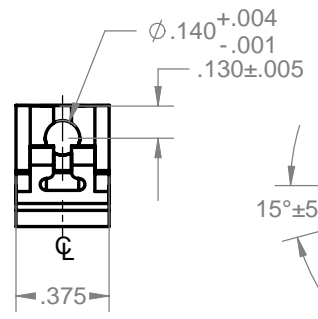
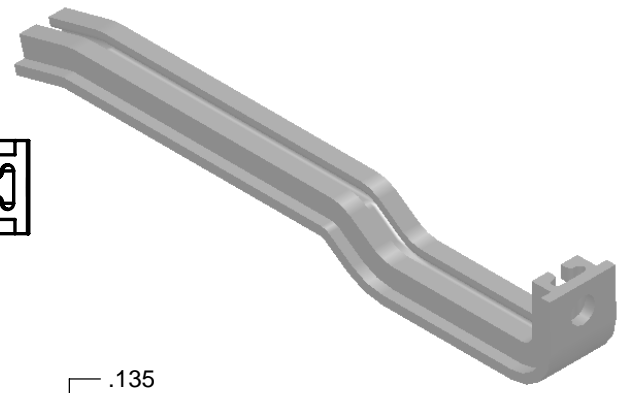
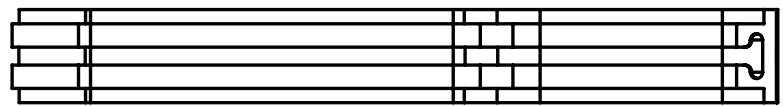
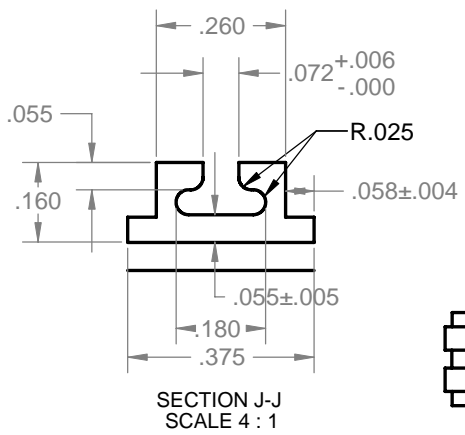

4. PARTS TO BE DEGREASED AFTER FABRICATION  
 3. PARTS TO BE FREE OF EXCESSIVE BURRS AND SURFACE SCRATCHES  
 2. FINISH: CLEAR ANODIZE  
 1. MATERIAL: ALUM. EXTRUSION 6063-T5
- NOTES: UNLESS OTHERWISE SPECIFIED.

**PROPRIETARY AND CONFIDENTIAL**  
 THE INFORMATION CONTAINED IN THIS DRAWING IS THE SOLE PROPERTY OF VECTOR ELECTRONICS & TECH., INC. ANY REPRODUCTION IN PART OR AS A WHOLE WITHOUT THE WRITTEN PERMISSION OF VECTOR ELECTRONICS & TECH., INC. IS PROHIBITED.

UNLESS OTHERWISE SPECIFIED:  
 DIMENSIONS ARE IN INCHES  
 TOLERANCES:  
 FRACTIONAL ±  
 ANGULAR: ±5°  
 TWO PLACE DECIMAL ±.03  
 THREE PLACE DECIMAL ±.010  
 INTERPRET GEOMETRIC TOLERANCING PER:  
 MATERIAL **1**  
 FINISH **2**  
 DO NOT SCALE DRAWING

NAME	DATE
DRAWN TRUSHAR	01/08/09
CHECKED	
ENG APPR.	
MFG APPR.	
Q.A.	

**VECTOR** ELECTRONICS & TECHNOLOGY, INC. CA 91605  
 11115 VANOWEN ST., NORTH HOLLYWOOD, CA 91605

**CARD GUIDE BR27-1**

SIZE DWG. NO. REV  
**B M5474-1-5 F**

SCALE: 1:1 WEIGHT: SHEET 1 OF 1



8 7 6 5 4 3 2 1

8 7 6 5 4 3 2 1

REVISIONS				
ZONE	REV.	DESCRIPTION	DATE	APPROVED
ALL	F		01/08/09	

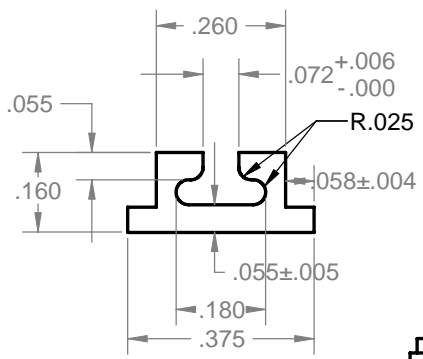

SECTION K-K  
SCALE 4 : 1

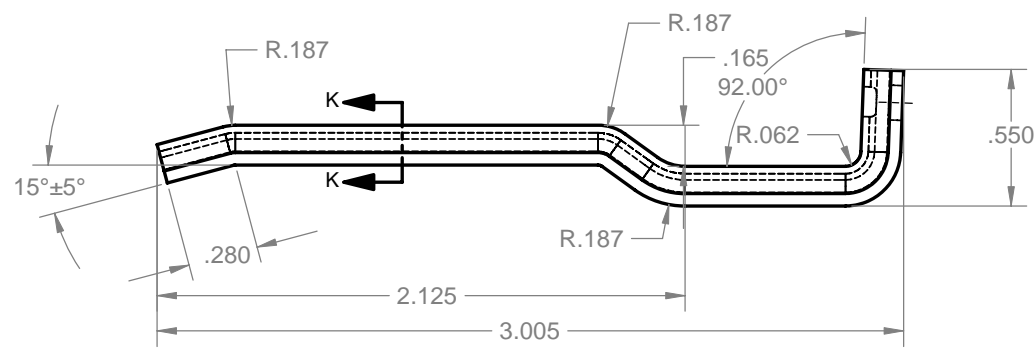
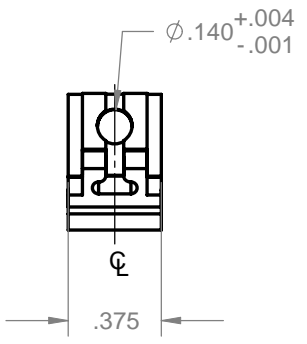
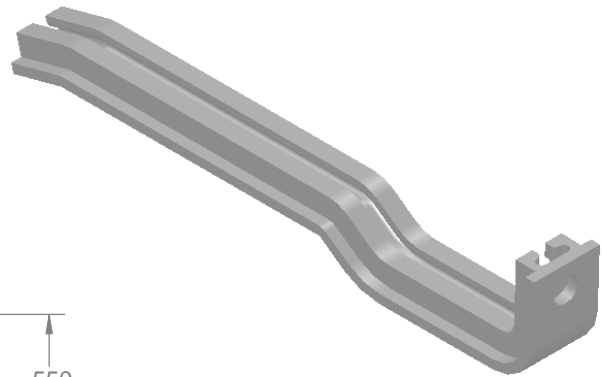

- 4. PARTS TO BE DEGREASED AFTER FABRICATION
- 3. PARTS TO BE FREE OF EXCESSIVE BURRS AND SURFACE SCRATCHES
- 2. FINISH: CLEAR ANODIZE
- 1. MATERIAL: ALUM. EXTRUSION 6063-T5

NOTES: UNLESS OTHERWISE SPECIFIED.

**PROPRIETARY AND CONFIDENTIAL**  
THE INFORMATION CONTAINED IN THIS DRAWING IS THE SOLE PROPERTY OF VECTOR ELECTRONICS & TECH., INC. ANY REPRODUCTION IN PART OR AS A WHOLE WITHOUT THE WRITTEN PERMISSION OF VECTOR ELECTRONICS & TECH., INC. IS PROHIBITED.

UNLESS OTHERWISE SPECIFIED:  
DIMENSIONS ARE IN INCHES  
TOLERANCES:  
FRACTIONAL ±  
ANGULAR: ±5°  
TWO PLACE DECIMAL ±.03  
THREE PLACE DECIMAL ±.010  
INTERPRET GEOMETRIC TOLERANCING PER:  
MATERIAL **1**  
FINISH **2**  
DO NOT SCALE DRAWING

NAME	DATE
DRAWN TRUSHAR	01/08/09
CHECKED	
ENG APPR.	
MFG APPR.	
Q.A.	

**VECTOR** ELECTRONICS & TECHNOLOGY, INC. 11115 VANOWEN ST., NORTH HOLLYWOOD, CA 91605

**CARD GUIDE BR27-5**

SIZE DWG. NO. **B M5474-1-12** REV **F**

SCALE: 1:1 WEIGHT: SHEET 1 OF 1



8 7 6 5 4 3 2 1



Компания «ЭлектроПласт» предлагает заключение долгосрочных отношений при поставках импортных электронных компонентов на взаимовыгодных условиях!

Наши преимущества:

- Оперативные поставки широкого спектра электронных компонентов отечественного и импортного производства напрямую от производителей и с крупнейших мировых складов;
- Поставка более 17-ти миллионов наименований электронных компонентов;
- Поставка сложных, дефицитных, либо снятых с производства позиций;
- Оперативные сроки поставки под заказ (от 5 рабочих дней);
- Экспресс доставка в любую точку России;
- Техническая поддержка проекта, помощь в подборе аналогов, поставка прототипов;
- Система менеджмента качества сертифицирована по Международному стандарту ISO 9001;
- Лицензия ФСБ на осуществление работ с использованием сведений, составляющих государственную тайну;
- Поставка специализированных компонентов (Xilinx, Altera, Analog Devices, Intersil, Interpoint, Microsemi, Aeroflex, Peregrine, Syfer, Eurofarad, Texas Instrument, Miteq, Cobham, E2V, MA-COM, Hittite, Mini-Circuits, General Dynamics и др.);

Помимо этого, одним из направлений компании «ЭлектроПласт» является направление «Источники питания». Мы предлагаем Вам помощь Конструкторского отдела:

- Подбор оптимального решения, техническое обоснование при выборе компонента;
- Подбор аналогов;
- Консультации по применению компонента;
- Поставка образцов и прототипов;
- Техническая поддержка проекта;
- Защита от снятия компонента с производства.



#### Как с нами связаться

**Телефон:** 8 (812) 309 58 32 (многоканальный)

**Факс:** 8 (812) 320-02-42

**Электронная почта:** [org@eplast1.ru](mailto:org@eplast1.ru)

**Адрес:** 198099, г. Санкт-Петербург, ул. Калинина, дом 2, корпус 4, литера А.