

R1LV5256E Series

256Kb Advanced LPSRAM (32k word x 8bit)

R10DS0269EJ0200
Rev.2.00
2019.10.29

Description

The R1LV5256E Series is a family of low voltage 256-Kbit static RAMs organized as 32,768-word by 8-bit, fabricated by Renesas's high-performance 0.15um CMOS and TFT technologies. The R1LV5256E Series has realized higher density, higher performance and low power consumption. The R1LV5256E Series is suitable for memory applications where a simple interfacing, battery operating and battery backup are the important design objectives. It has been packaged in 28-pin SOP and 28-pin TSOP.

Features

- Single 2.7V~3.6V power supply
- Small stand-by current: 0.6μA (3.0V, typical)
- No clocks, No refresh
- All inputs and outputs are TTL compatible.
- Easy memory expansion by CS#
- Common Data I/O
- Three-state outputs: OR-tie Capability
- OE# prevents data contention on the I/O bus

Ordering Information

Orderable part name	Access time	Temperature range	Package	Shipping container
R1LV5256ESP-5SI#B*	55 ns	-40 ~ +85°C	450-mil 28-pin plastic SOP	Tube (Magazine)
R1LV5256ESP-5SI#S*				Embossed tape
R1LV5256ESA-5SI#B*			8mm×13.4mm 28-pin plastic TSOP	Tray
R1LV5256ESA-5SI#S*				Embossed tape

Note 1. * = Revision code for Assembly site change, etc. (* = 0, 1, etc.)

Pin Arrangement

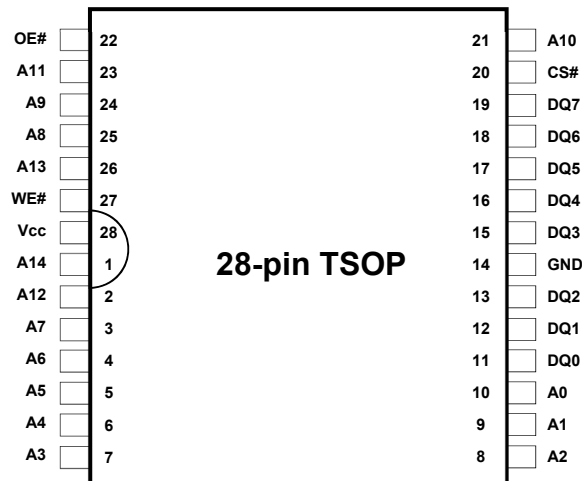
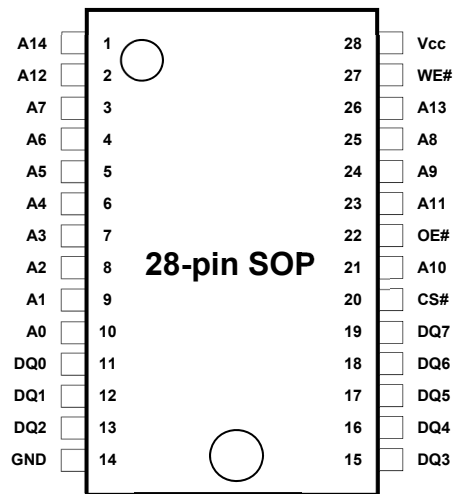

Pin Description

Pin name	Function
Vcc	Power supply
Vss (GND)	Ground
A0 to A14	Address input
DQ0 to DQ7	Data input/output
CS#	Chip select
WE#	Write enable
OE#	Output enable

Block Diagram

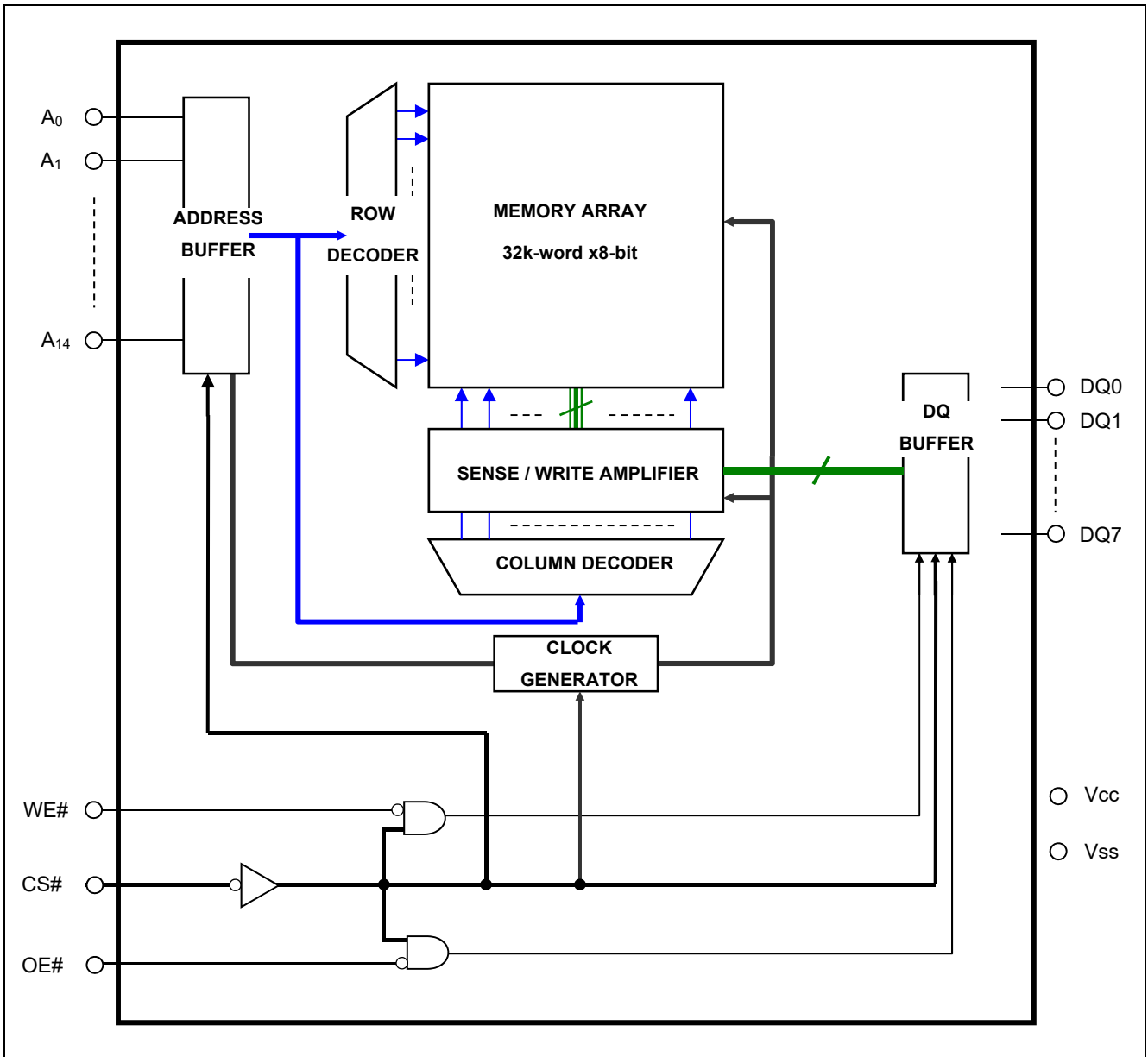

Operation Table

CS#	WE#	OE#	DQ0~7	Operation
H	X	X	High-Z	Stand-by
L	L	X	Din	Write
L	H	L	Dout	Read
L	H	H	High-Z	Output disable

Note 1. H: V_{IH} L: V_{IL} X: V_{IH} or V_{IL}

Absolute Maximum

Parameter	Symbol	Value	unit
Power supply voltage relative to Vss	Vcc	-0.3 to +4.6	V
Terminal voltage on any pin relative to Vss	V_T	-0.3^{*1} to $V_{cc}+0.3^{*2}$	V
Power dissipation	P_T	0.7	W
Operation temperature	Topr	-40 to +85	°C
Storage temperature range	Tstg	-65 to 150	°C
Storage temperature range under bias	Tbias	-40 to +85	°C

Note 1. -3.0V for pulse ≤ 30 ns (full width at half maximum)
 2. Maximum voltage is +4.6V.

DC Operating Conditions

Parameter	Symbol	Min.	Typ.	Max.	Unit	Note
Supply voltage	V _{CC}	2.7	3.0	3.6	V	
	V _{SS}	0	0	0	V	
Input high voltage	V _{IH}	2.0	-	V _{CC} +0.3	V	
Input low voltage	V _{IL}	-0.3	-	0.6	V	1
Ambient temperature range	T _a	-40	-	+85	°C	

Note 1. -3.0V for pulse ≤ 30ns (full width at half maximum)

DC Characteristics

Parameter	Symbol	Min.	Typ.	Max.	Unit	Test conditions	
Input leakage current	I _{LI}	-	-	1	μA	V _{in} = V _{SS} to V _{CC}	
Output leakage current	I _{LO}	-	-	1	μA	CS# = V _{IH} or OE# = V _{IH} , V _{I/O} = V _{SS} to V _{CC}	
Average operating current	I _{CC1}	-	14	25	mA	Min. cycle, duty = 100%, I _{I/O} = 0mA, CS# = V _{IL} , Others = V _{IH} /V _{IL}	
	I _{CC2}	-	2	5	mA	Cycle = 1μs, duty = 100%, I _{I/O} = 0mA, CS# ≤ 0.2V, V _{IH} ≥ V _{CC} -0.2V, V _{IL} ≤ 0.2V	
Standby current	I _{SB}	-	-	0.33	mA	CS# = V _{IH} , Others = V _{SS} to V _{CC}	
Standby current	I _{SB1}	-	0.6 ¹	2	μA	~+25°C	V _{in} = V _{SS} to V _{CC} , CS# ≥ V _{CC} -0.2V
		-	-	3	μA	~+40°C	
		-	-	8	μA	~+70°C	
		-	-	10	μA	~+85°C	
Output high voltage	V _{OH}	2.4	-	-	V	I _{OH} = -0.5mA	
	V _{OH2}	V _{CC} - 0.5	-	-	V	I _{OH} = -0.05mA	
Output low voltage	V _{OL}	-	-	0.4	V	I _{OL} = 1mA	

Note 1. Typical parameter indicates the value for the center of distribution at 3.0V (T_a = 25°C), and not 100% tested.

Capacitance

(V_{CC} = 2.7V ~ 3.6V, f = 1MHz, T_a = -40 ~ +85°C)

Parameter	Symbol	Min.	Typ.	Max.	Unit	Test conditions	Note
Input capacitance	C _{in}	-	-	6	pF	V _{in} = 0V	1
Input / output capacitance	C _{I/O}	-	-	8	pF	V _{I/O} = 0V	1

Note 1. This parameter is sampled and not 100% tested.

AC Characteristics

Test Conditions ($V_{CC} = 2.7V \sim 3.6V$, $T_a = -40 \sim +85^{\circ}C$)

- Input pulse levels: $V_{IL} = 0.4V$, $V_{IH} = 2.4V$
- Input rise and fall time: 5ns
- Input and output timing reference level: 1.5V
- Output load: See figures (Including scope and jig)

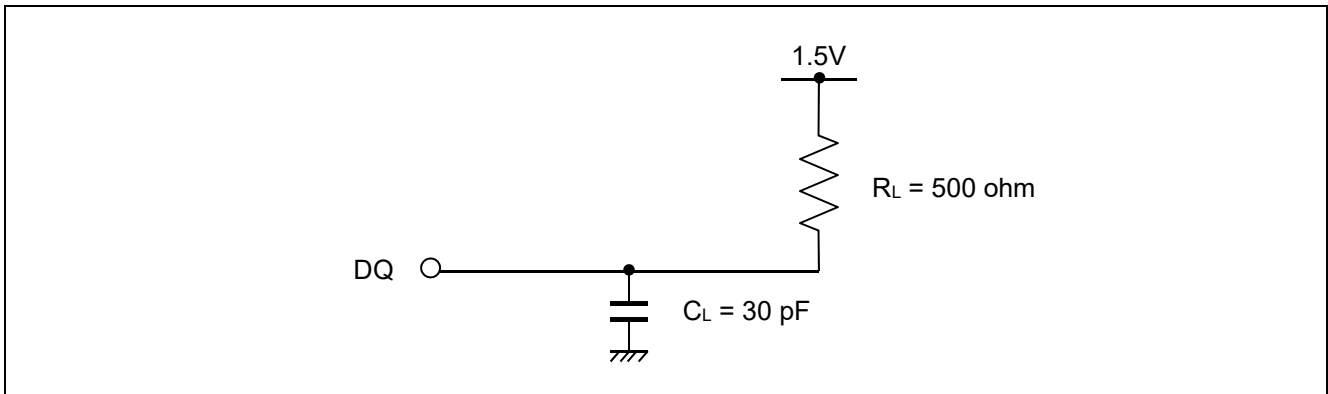

Read Cycle

Parameter	Symbol	Min.	Max.	Unit	Note
Read cycle time	t _{RC}	55	-	ns	
Address access time	t _{AA}	-	55	ns	
Chip select access time	t _{ACS}	-	55	ns	
Output enable to output valid	t _{OE}	-	30	ns	
Output hold from address change	t _{OH}	10	-	ns	
Chip select to output in low-Z	t _{CLZ}	5	-	ns	2,3
Output enable to output in low-Z	t _{OLZ}	5	-	ns	2,3
Chip deselect to output in high-Z	t _{CHZ}	0	20	ns	1,2,3
Output disable to output in high-Z	t _{OHZ}	0	20	ns	1,2,3

Write Cycle

Parameter	Symbol	Min.	Max.	Unit	Note
Write cycle time	t _{WC}	55	-	ns	
Address valid to end of write	t _{AW}	50	-	ns	
Chip select to end of write	t _{CW}	50	-	ns	5
Write pulse width	t _{WP}	40	-	ns	4
Address setup time	t _{AS}	0	-	ns	6
Write recovery time	t _{WR}	0	-	ns	7
Data to write time overlap	t _{DW}	25	-	ns	
Data hold from write time	t _{DH}	0	-	ns	
Output enable from end of write	t _{OW}	5	-	ns	2
Output disable to output in high-Z	t _{OHZ}	0	20	ns	1,2
Write to output in high-Z	t _{WHZ}	0	20	ns	1,2

- Note
1. t_{CHZ}, t_{OHZ} and t_{WHZ} are defined as the time at which the outputs achieve the open circuit conditions and are not referred to output voltage levels.
 2. This parameter is sampled and not 100% tested.
 3. At any given temperature and voltage condition, t_{HZ} max is less than t_{LZ} min both for a given device and from device to device.
 4. A write occurs during the overlap of a low CS#, a low WE#.
 - A write begins at the latest transition among CS# going low and WE# going low.
 - A write ends at the earliest transition among CS# going high and WE# going high.
 - t_{WP} is measured from the beginning of write to the end of write.
 5. t_{CW} is measured from the later of CS# going low to end of write.
 6. t_{AS} is measured the address valid to the beginning of write.
 7. t_{WR} is measured from the earliest of CS# or WE# going high to the end of write cycle.
 8. Don't apply inverted phase signal externally when DQ pin is output mode.

Timing Waveforms

Read Cycle

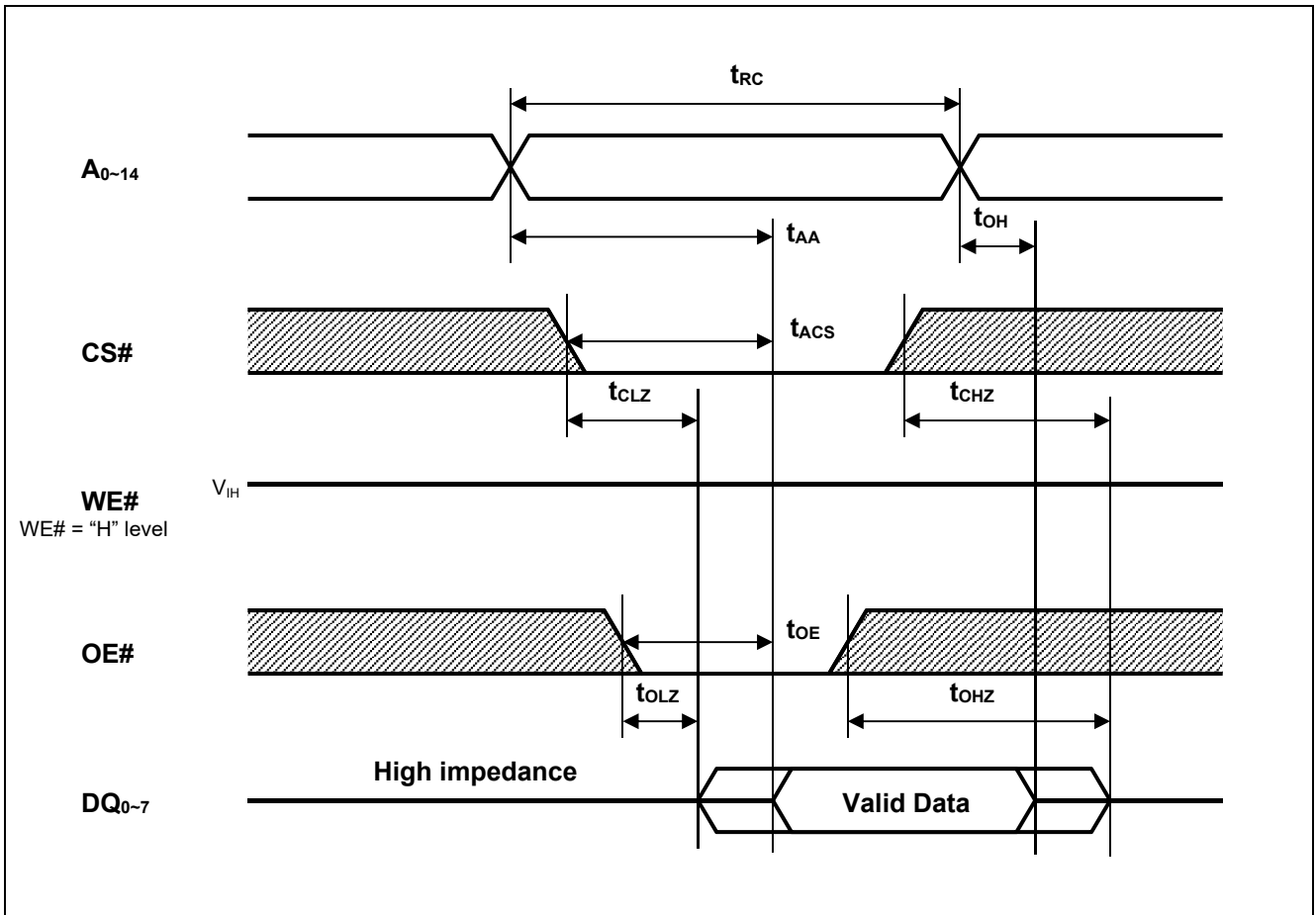

Write Cycle (1) (WE# CLOCK)

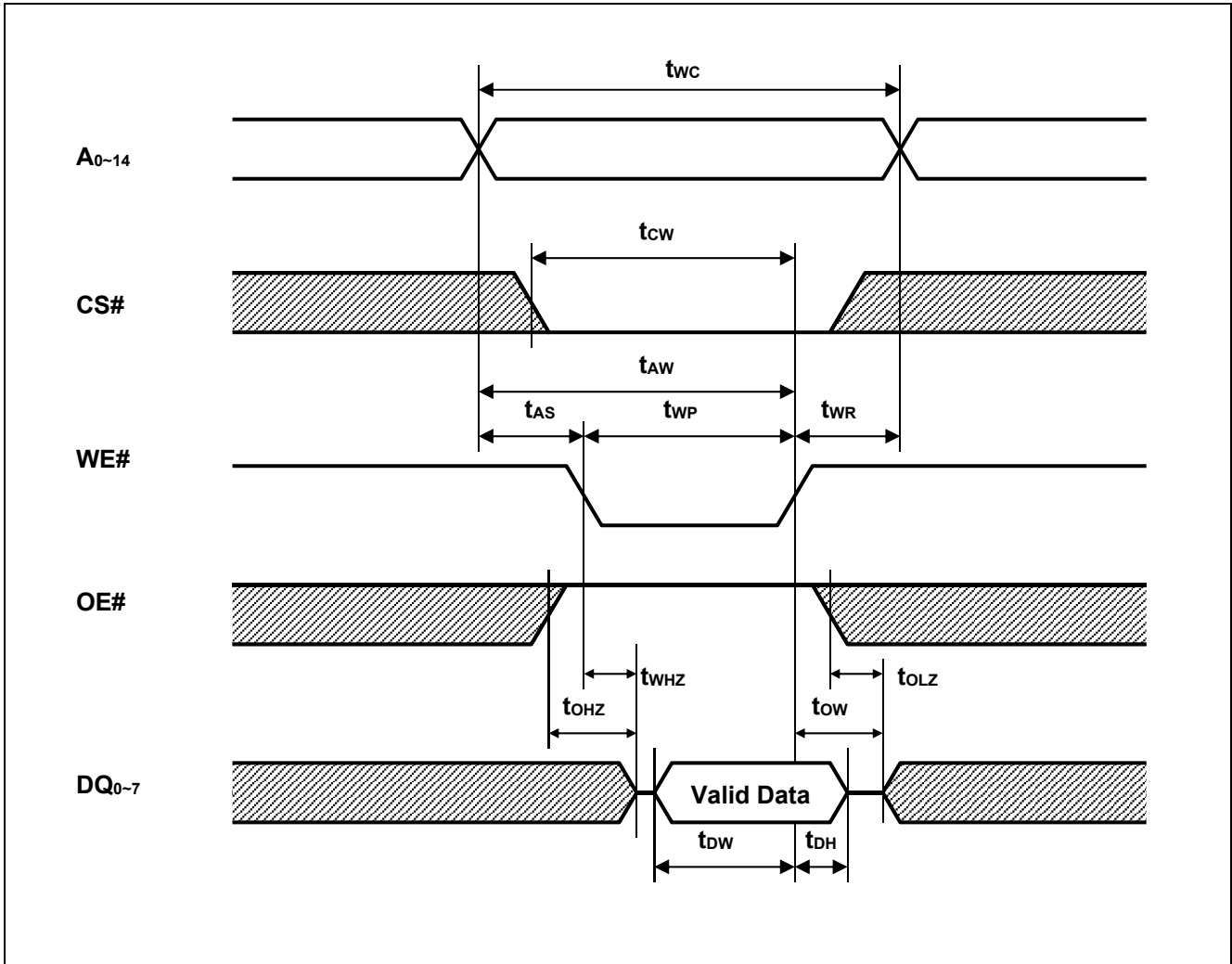

Write Cycle (2) (CS# CLOCK)

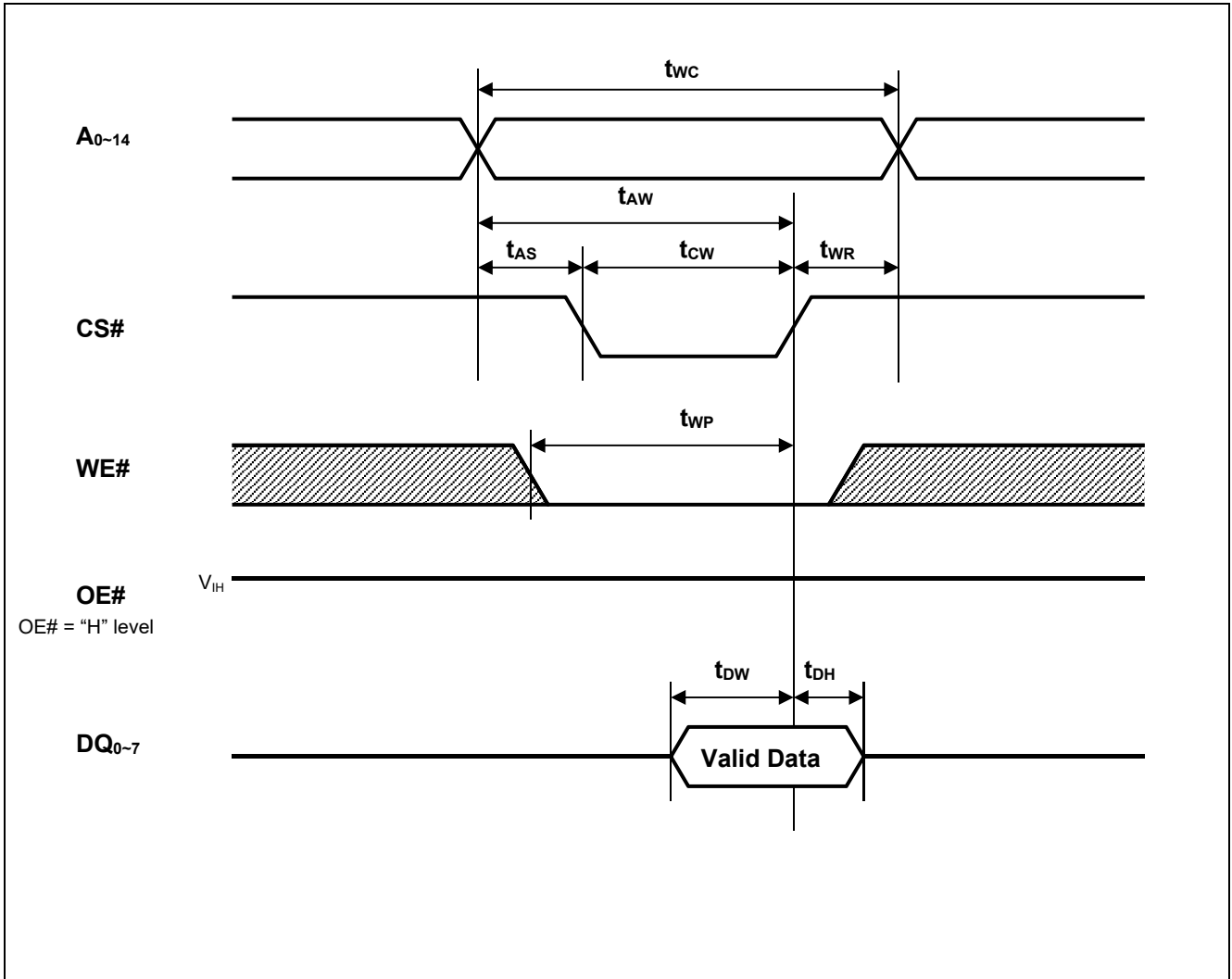

Low Vcc Data Retention Characteristics

Parameter	Symbol	Min.	Typ.	Max.	Unit	Test conditions ²	
V _{CC} for data retention	V _{DR}	2.0	-	3.6	V	V _{in} ≥ 0V, CS# ≥ V _{CC} -0.2V	
Data retention current	I _{CCDR}	-	0.6 ^{*1}	2	μA	~+25°C	V _{CC} =3.0V, V _{in} ≥ 0V, CS# ≥ V _{CC} -0.2V
		-	-	3	μA	~+40°C	
		-	-	8	μA	~+70°C	
		-	-	10	μA	~+85°C	
Chip deselect time to data retention	t _{CDR}	0	-	-	ns	See retention waveform.	
Operation recovery time	t _R	5	-	-	ms		

- Note
1. Typical parameter indicates the value for the center of distribution at 3.0V (T_a= 25°C), and not 100% tested.
 2. CS# controls address buffer, WE# buffer, OE# buffer and Din buffer. If CS# controls data retention mode, V_{in} levels (address, WE#, OE#, DQ) can be in the high impedance state.

Low Vcc Data Retention Timing Waveforms

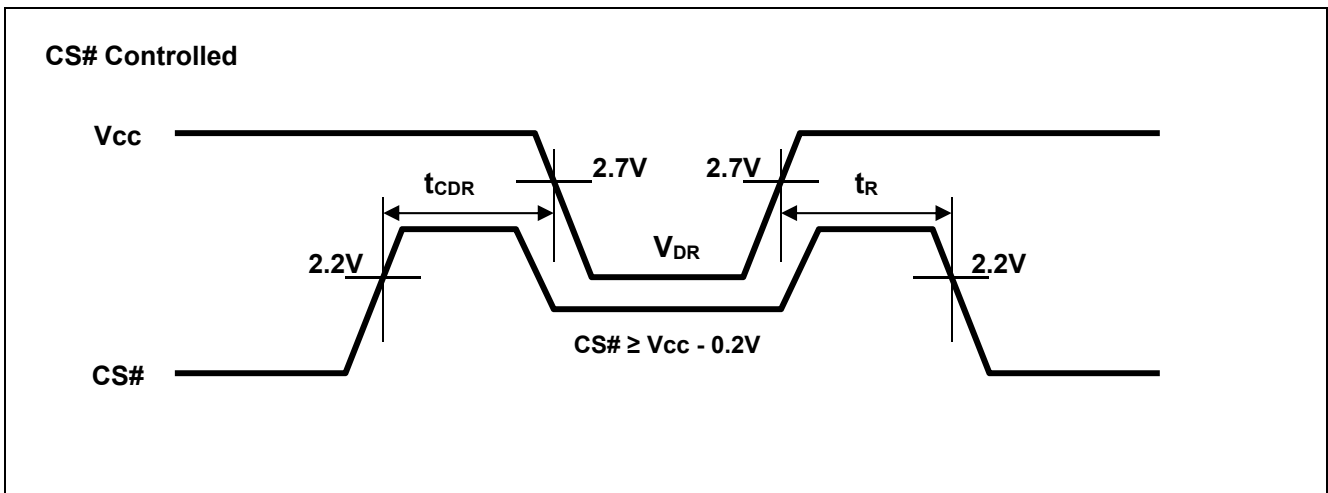

Revision History	R1LV5256E Series Data Sheet
------------------	-----------------------------

Rev.	Date	Description	
		Page	Summary
1.00	2017.1.27	-	First Edition issued
2.00	2019.10.29	p.1	Revised orderable part name information.

Notice

1. Descriptions of circuits, software and other related information in this document are provided only to illustrate the operation of semiconductor products and application examples. You are fully responsible for the incorporation or any other use of the circuits, software, and information in the design of your product or system. Renesas Electronics disclaims any and all liability for any losses and damages incurred by you or third parties arising from the use of these circuits, software, or information.
2. Renesas Electronics hereby expressly disclaims any warranties against and liability for infringement or any other claims involving patents, copyrights, or other intellectual property rights of third parties, by or arising from the use of Renesas Electronics products or technical information described in this document, including but not limited to, the product data, drawings, charts, programs, algorithms, and application examples.
3. No license, express, implied or otherwise, is granted hereby under any patents, copyrights or other intellectual property rights of Renesas Electronics or others.
4. You shall not alter, modify, copy, or reverse engineer any Renesas Electronics product, whether in whole or in part. Renesas Electronics disclaims any and all liability for any losses or damages incurred by you or third parties arising from such alteration, modification, copying or reverse engineering.
5. Renesas Electronics products are classified according to the following two quality grades: "Standard" and "High Quality". The intended applications for each Renesas Electronics product depends on the product's quality grade, as indicated below.
"Standard": Computers; office equipment; communications equipment; test and measurement equipment; audio and visual equipment; home electronic appliances; machine tools; personal electronic equipment; industrial robots; etc.
"High Quality": Transportation equipment (automobiles, trains, ships, etc.); traffic control (traffic lights); large-scale communication equipment; key financial terminal systems; safety control equipment; etc.
Unless expressly designated as a high reliability product or a product for harsh environments in a Renesas Electronics data sheet or other Renesas Electronics document, Renesas Electronics products are not intended or authorized for use in products or systems that may pose a direct threat to human life or bodily injury (artificial life support devices or systems; surgical implantations; etc.), or may cause serious property damage (space system; undersea repeaters; nuclear power control systems; aircraft control systems; key plant systems; military equipment; etc.). Renesas Electronics disclaims any and all liability for any damages or losses incurred by you or any third parties arising from the use of any Renesas Electronics product that is inconsistent with any Renesas Electronics data sheet, user's manual or other Renesas Electronics document.
6. When using Renesas Electronics products, refer to the latest product information (data sheets, user's manuals, application notes, "General Notes for Handling and Using Semiconductor Devices" in the reliability handbook, etc.), and ensure that usage conditions are within the ranges specified by Renesas Electronics with respect to maximum ratings, operating power supply voltage range, heat dissipation characteristics, installation, etc. Renesas Electronics disclaims any and all liability for any malfunctions, failure or accident arising out of the use of Renesas Electronics products outside of such specified ranges.
7. Although Renesas Electronics endeavors to improve the quality and reliability of Renesas Electronics products, semiconductor products have specific characteristics, such as the occurrence of failure at a certain rate and malfunctions under certain use conditions. Unless designated as a high reliability product or a product for harsh environments in a Renesas Electronics data sheet or other Renesas Electronics document, Renesas Electronics products are not subject to radiation resistance design. You are responsible for implementing safety measures to guard against the possibility of bodily injury, injury or damage caused by fire, and/or danger to the public in the event of a failure or malfunction of Renesas Electronics products, such as safety design for hardware and software, including but not limited to redundancy, fire control and malfunction prevention, appropriate treatment for aging degradation or any other appropriate measures. Because the evaluation of microcomputer software alone is very difficult and impractical, you are responsible for evaluating the safety of the final products or systems manufactured by you.
8. Please contact a Renesas Electronics sales office for details as to environmental matters such as the environmental compatibility of each Renesas Electronics product. You are responsible for carefully and sufficiently investigating applicable laws and regulations that regulate the inclusion or use of controlled substances, including without limitation, the EU RoHS Directive, and using Renesas Electronics products in compliance with all these applicable laws and regulations. Renesas Electronics disclaims any and all liability for damages or losses occurring as a result of your noncompliance with applicable laws and regulations.
9. Renesas Electronics products and technologies shall not be used for or incorporated into any products or systems whose manufacture, use, or sale is prohibited under any applicable domestic or foreign laws or regulations. You shall comply with any applicable export control laws and regulations promulgated and administered by the governments of any countries asserting jurisdiction over the parties or transactions.
10. It is the responsibility of the buyer or distributor of Renesas Electronics products, or any other party who distributes, disposes of, or otherwise sells or transfers the product to a third party, to notify such third party in advance of the contents and conditions set forth in this document.
11. This document shall not be reprinted, reproduced or duplicated in any form, in whole or in part, without prior written consent of Renesas Electronics.
12. Please contact a Renesas Electronics sales office if you have any questions regarding the information contained in this document or Renesas Electronics products.
(Note 1) "Renesas Electronics" as used in this document means Renesas Electronics Corporation and also includes its directly or indirectly controlled subsidiaries.
(Note 2) "Renesas Electronics product(s)" means any product developed or manufactured by or for Renesas Electronics.

(Rev.4.0-1 November 2017)



SALES OFFICES

Renesas Electronics Corporation

<http://www.renesas.com>

Refer to "<http://www.renesas.com/>" for the latest and detailed information.

Renesas Electronics Corporation
TOYOSU FORESIA, 3-2-24 Toyosu, Koto-ku, Tokyo 135-0061, Japan

Renesas Electronics America Inc.
1001 Murphy Ranch Road, Milpitas, CA 95035, U.S.A.
Tel: +1-408-432-8888, Fax: +1-408-434-5351

Renesas Electronics Canada Limited
9251 Yonge Street, Suite 8309 Richmond Hill, Ontario Canada L4C 9T3
Tel: +1-905-237-2004

Renesas Electronics Europe GmbH
Arcadiastrasse 10, 40472 Düsseldorf, Germany
Tel: +49-211-6503-0, Fax: +49-211-6503-1327

Renesas Electronics (China) Co., Ltd.
Room 101-T01, Floor 1, Building 7, Yard No. 7, 8th Street, Shangdi, Haidian District, Beijing 100085, China
Tel: +86-10-8235-1155, Fax: +86-10-8235-7679

Renesas Electronics (Shanghai) Co., Ltd.
Unit 301, Tower A, Central Towers, 555 Langao Road, Putuo District, Shanghai 200333, China
Tel: +86-21-2226-0888, Fax: +86-21-2226-0999

Renesas Electronics Hong Kong Limited
Unit 1601-1611, 16/F., Tower 2, Grand Century Place, 193 Prince Edward Road West, Mongkok, Kowloon, Hong Kong
Tel: +852-2265-6688, Fax: +852 2886-9022

Renesas Electronics Taiwan Co., Ltd.
13F, No. 363, Fu Shing North Road, Taipei 10543, Taiwan
Tel: +886-2-8175-9600, Fax: +886 2-8175-9670

Renesas Electronics Singapore Pte. Ltd.
80 Bendemeer Road, Unit #06-02 Hyflux Innovation Centre, Singapore 339949
Tel: +65-6213-0200, Fax: +65-6213-0300

Renesas Electronics Malaysia Sdn.Bhd.
Unit No 3A-1 Level 3A Tower 8 UOA Business Park, No 1 Jalan Pengaturcara U1/51A, Seksyen U1, 40150 Shah Alam, Selangor, Malaysia
Tel: +60-3-5022-1288, Fax: +60-3-5022-1290

Renesas Electronics India Pvt. Ltd.
No.777C, 100 Feet Road, HAL 2nd Stage, Indiranagar, Bangalore 560 038, India
Tel: +91-80-67208700

Renesas Electronics Korea Co., Ltd.
17F, KAMCO Yangjae Tower, 262, Gangnam-daero, Gangnam-gu, Seoul, 06265 Korea
Tel: +82-2-558-3737, Fax: +82-2-558-5338



Компания «ЭлектроПласт» предлагает заключение долгосрочных отношений при поставках импортных электронных компонентов на взаимовыгодных условиях!

Наши преимущества:

- Оперативные поставки широкого спектра электронных компонентов отечественного и импортного производства напрямую от производителей и с крупнейших мировых складов;
- Поставка более 17-ти миллионов наименований электронных компонентов;
- Поставка сложных, дефицитных, либо снятых с производства позиций;
- Оперативные сроки поставки под заказ (от 5 рабочих дней);
- Экспресс доставка в любую точку России;
- Техническая поддержка проекта, помощь в подборе аналогов, поставка прототипов;
- Система менеджмента качества сертифицирована по Международному стандарту ISO 9001;
- Лицензия ФСБ на осуществление работ с использованием сведений, составляющих государственную тайну;
- Поставка специализированных компонентов (Xilinx, Altera, Analog Devices, Intersil, Interpoint, Microsemi, Aeroflex, Peregrine, Syfer, Eurofarad, Texas Instrument, Miteq, Cobham, E2V, MA-COM, Hittite, Mini-Circuits, General Dynamics и др.);

Помимо этого, одним из направлений компании «ЭлектроПласт» является направление «Источники питания». Мы предлагаем Вам помощь Конструкторского отдела:

- Подбор оптимального решения, техническое обоснование при выборе компонента;
- Подбор аналогов;
- Консультации по применению компонента;
- Поставка образцов и прототипов;
- Техническая поддержка проекта;
- Защита от снятия компонента с производства.



Как с нами связаться

Телефон: 8 (812) 309 58 32 (многоканальный)

Факс: 8 (812) 320-02-42

Электронная почта: org@eplast1.ru

Адрес: 198099, г. Санкт-Петербург, ул. Калинина, дом 2, корпус 4, литера А.