

3M™ Scotchcast™ Flexible Power Cable Splice Kit 82-BF1

For use in weather-exposed, direct burial or submerged locations and for making tap splices on Non-shielded portable power cables and cords rated up to 1000 Volts

Installation Instructions

Kit Contents:

- 1 Removable Mold
- 1 Size B Bag 3M™ Scotchcast™ Flame-Retardant Compound 2131
- 3 Strips, Scotch® Rubber Splicing Tape 23
- 1 Strip 3M™ Three-M-It™ Elek-Tro-Cut™ Abrasive Cloth

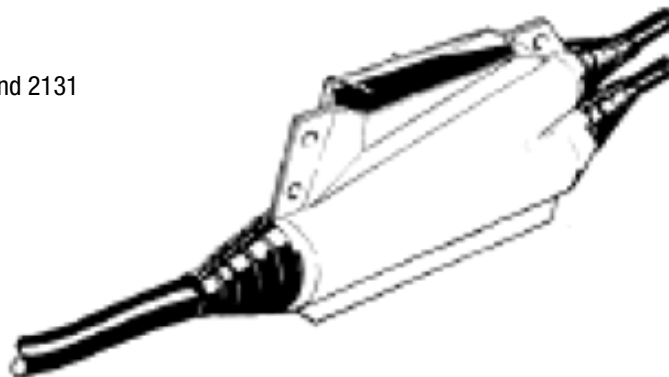

This kit will accommodate the following copper connector and conductor sizes:

Kit No.	Cable O.D. Range (inches)	Connector Types	Number of Conductors	Conductor Size Range (AWG)
82-BF1	0.25 – 0.80	Compression "C" Tap	1	Up to 1/0
			Multi	*

* Base selection on cable O.D. range above

DANGER: BEFORE ATTEMPTING ANY CABLE REPAIRS, MAKE SURE THAT THE PROPER CABLE IS DISCONNECTED, LOCKED OUT AND SUITABLY TAGGED.



Caution: Working around energized systems may cause serious injury or death. Installation should be performed by personnel familiar with good safety practice in handling electrical equipment. De-energize and ground all electrical systems before installing product.

Technical Information: For use on Non-shielded Portable Power Cable & Portable Cords: - Up to 1000 V & 600/2000 V - Single Conductor Up to 1/0 AWG - Multi-Conductor OD Range: 0.25 " – 0.80" Mine Safety and Health Administration Acceptance: 07-KA060002-MSHA	3M™ Scotchcast™ Flexible Power Cable Tap Splice Kit 82-BF1
	78-8126-9785-8

June, 2011

B. INSTALL CONNECTOR(S)

1. **Multi-Conductors:** Phase match conductors to appropriate color codes, if applicable.
2. Join conductors with proper connector(s) and appropriate crimping tool and die.

C. INSULATE CONNECTION(S) Multi-Conductors Only

1. Overwrap connector(s) with 4 half-lapped layers of vinyl electrical tape (e.g. Scotch® Super 33+™ Vinyl Electrical Tape) extending 1/4" onto conductor insulations.
2. Bundle conductors together with a band of vinyl tape wrapped around the center of the splice opening.

D. Install Mold

1. Trim tapered ends of mold with knife or diagonal cutting pliers to fit cable diameters. (Figure 4)

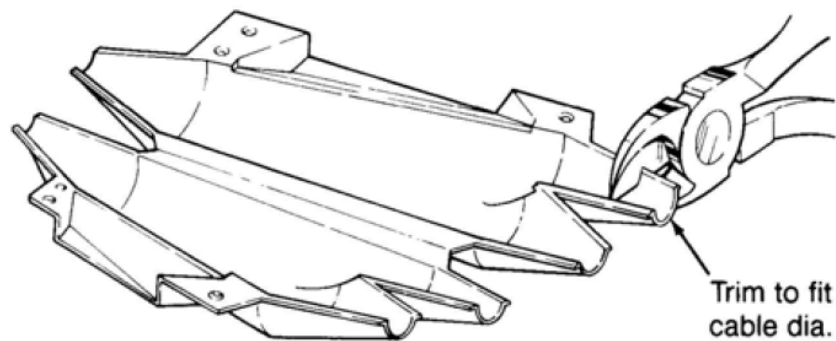

Figure 4

2. Center mold over splice and tape into place by applying Scotch® Rubber Splicing Tape 23 (provided in kit) over the mold ends and onto the cable. (Figure 5)

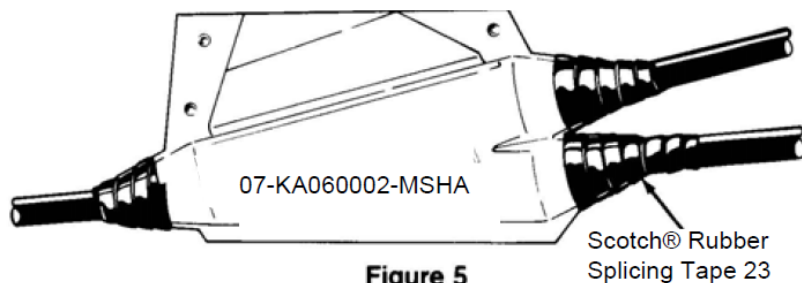

Figure 5

- Center splice within the mold by tensioning (pulling) cables from both ends.

Hint: Use empty kit carton as a work stand.

- Make a straight knife slit in cover of closed carton that is slightly longer than the mold's hinge. (Figure 6)

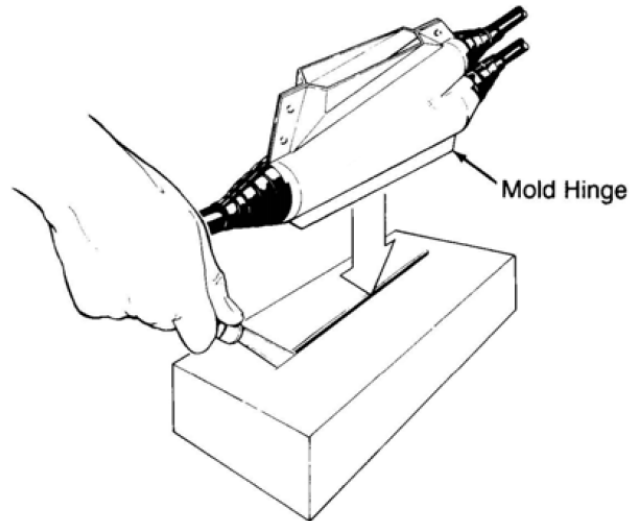

Figure 6

- Position carton beneath splice and press the mold's hinge into the knife slit. This holds splice in position for compound pouring. (Figure 6)

E. Pour Compound

- Premix BLACK side of 3M™ Scotchcast™ Flame-Retardant Compound 2131 pouch by squeezing to a smooth consistency and uniform color.
- Firmly grasp each flat side of the closed mixing pouch near the center barrier; at the same time pull sides of barrier apart and roll sides of thumbs through barrier. Break the barrier all the way across to the side seals. (Figure 7)

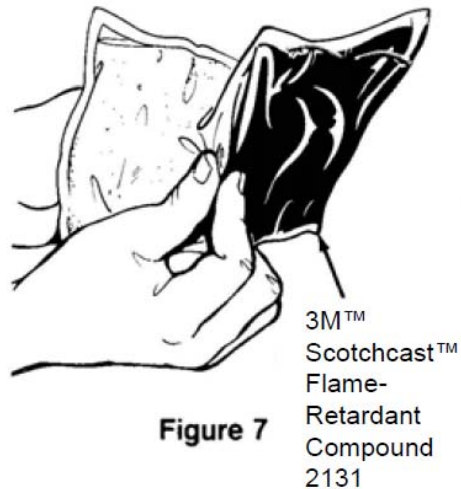

Figure 7

3. Alternately squeeze ends of pouch forcing compound rapidly back and forth, then strip compound from corners of pouch between fingers. Mix until color is completely uniform – 30 to 40 VIGOROUS SQUEEZES. **DO NOT EXCEED 1 MINUTE.** (Figure 8)



Figure 8

4. Clip off a corner of pouch and immediately pour into mold.
5. Fill mold until compound reaches a level that is within the mold's filler spout. (Figure 9)

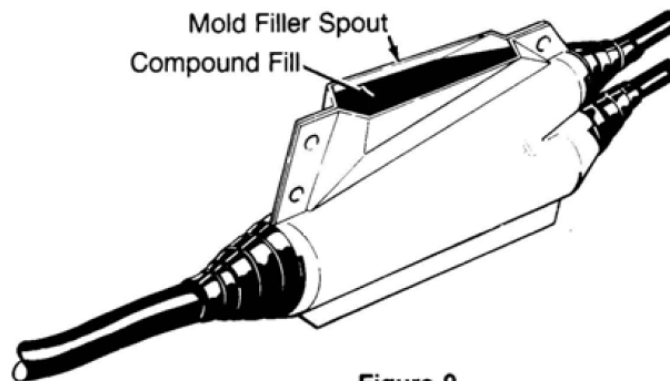

Figure 9

6. Allow compound to cure. Check compound in Filler Spout for curing.
NOTE: Splice may be de-molded when compound is no longer tacky.

Typical Cure Time: 16 – 24 hrs. @ 70°F (21°C)
24 – 30 hrs. @ 50°F (10°C)
36 hrs. @ 32°F (0°C)

Typical De-mold Time: 1.5 hrs. @ 70°F (21°C)
4 hrs. @ 50°F (10°C)
6 – 8 hrs. @ 32°F (0°C)

NOTE: Values are typical, not to be considered minimum or maximum. Always confirm based on tack and hardness of compound that resin is sufficiently cured.

F. De-mold

1. Remove Scotch® Rubber Splicing Tape 23 from mold ends.
2. Remove mold; start removal by first separating mold halves at the filler spout.
3. Trim off excess compound from filler spout by cutting off at base. (Figure 10)

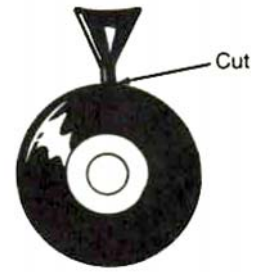

Figure 10

3M, Scotch, Scotchcast, Super 33+, Three-M-Itte and Elek-Tro-Cut are trademarks of 3M Company.

Important Notice:

All statements, technical information, and recommendations related to 3M's products are based on information believed to be reliable, but the accuracy or completeness is not guaranteed. Before using this product, you must evaluate it and determine if it is suitable for your intended application. You assume all risks and liability associated with such use. Any statements related to the product, which are not contained in 3M's current publications, or any contrary statements contained on your purchase order, shall have no force or effect unless expressly agreed upon, in writing, by an authorized officer of 3M.

Warranty; Limited Remedy; Limited Liability:

This product will be free from defects in material and manufacture at the time of purchase. 3M MAKES NO OTHER WARRANTIES INCLUDING, BUT NOT LIMITED TO, ANY IMPLIED WARRANTY OF MERCHANTABILITY OR FITNESS FOR A PARTICULAR PURPOSE. If this product is defective within the warranty period stated above, your exclusive remedy shall be, at 3M's option, to replace or repair the 3M product or refund the purchase price of the 3M product. Except where prohibited by law, 3M will not be liable for any indirect, special, incidental or consequential loss or damage arising from this 3M product, regardless of the legal theory asserted.



Electrical Markets Division
6801 River Place Blvd.
Austin, TX 78726-9000
800.245.3573
Fax 800.245.0329
www.3M.com/electrical

Please Recycle. Printed in USA.
© 3M 2011 All Rights Reserved.
78-8126-9785-8 A



Компания «ЭлектроПласт» предлагает заключение долгосрочных отношений при поставках импортных электронных компонентов на взаимовыгодных условиях!

Наши преимущества:

- Оперативные поставки широкого спектра электронных компонентов отечественного и импортного производства напрямую от производителей и с крупнейших мировых складов;
- Поставка более 17-ти миллионов наименований электронных компонентов;
- Поставка сложных, дефицитных, либо снятых с производства позиций;
- Оперативные сроки поставки под заказ (от 5 рабочих дней);
- Экспресс доставка в любую точку России;
- Техническая поддержка проекта, помощь в подборе аналогов, поставка прототипов;
- Система менеджмента качества сертифицирована по Международному стандарту ISO 9001;
- Лицензия ФСБ на осуществление работ с использованием сведений, составляющих государственную тайну;
- Поставка специализированных компонентов (Xilinx, Altera, Analog Devices, Intersil, Interpoint, Microsemi, Aeroflex, Peregrine, Syfer, Eurofarad, Texas Instrument, Miteq, Cobham, E2V, MA-COM, Hittite, Mini-Circuits, General Dynamics и др.);

Помимо этого, одним из направлений компании «ЭлектроПласт» является направление «Источники питания». Мы предлагаем Вам помощь Конструкторского отдела:

- Подбор оптимального решения, техническое обоснование при выборе компонента;
- Подбор аналогов;
- Консультации по применению компонента;
- Поставка образцов и прототипов;
- Техническая поддержка проекта;
- Защита от снятия компонента с производства.



Как с нами связаться

Телефон: 8 (812) 309 58 32 (многоканальный)

Факс: 8 (812) 320-02-42

Электронная почта: org@eplast1.ru

Адрес: 198099, г. Санкт-Петербург, ул. Калинина, дом 2, корпус 4, литера А.