

Si1146 UVIRSLIDER2EK DEMO KIT USER'S GUIDE

1. Kit Contents

The Si1146 UVIRSlider2EK Demo Kit contains the following items:

- Si1146 UVIRSlider2EK Demo Board
- Si1146 UVIRSlider2EK Demo Board Quick Start Guide
- USB Cable

2. Introduction

The Si1146 UVIRSlider2EK Demo Board implements a UV Index sensing function based around the Si1146 UV, infrared proximity, and ambient light sensor. As shown in Figure 1, the main components of the board are the Si1146 sensor (U2), the C8051F800 microcontroller (U1), and two infrared emitters (DS1 and DS2). Hardware is also provided on-board to facilitate code development for the C8051F800 and communications with software support packages over a USB interface.

The firmware running on the C8051F800 measures the UV Index of the environment of the Si1146 sensor and indicates the UV Index detected by illuminating blue LEDs on the board.

The board is also capable of running a touchless slider algorithm using infrared light energy detected by the Si1146, while each of the two infrared emitters are independently activated. The infrared light from these emitters will be reflected back to the Si1146 by any object that is placed in proximity to the board. The left-right position is then calculated from these two measurements and used to illuminate the appropriate signal LED. If no object is close enough to the board, the measured signal levels will fall below pre-determined thresholds, and no signal LEDs will be illuminated. In addition to indicating the current position, the algorithm is also able to detect different gestures from the infrared sensor, as described in Table 2 on page 3. The Si1146's ambient light sensor (ALS) is also monitored by the software, which can determine the amount of ambient light present.

On this board, the infrared emitters used are OSRAM part number SFH 4056. These emitters have a power rating of 40 mW and a half-angle of 22 degrees. Other emitters with different characteristics may also be used, depending on the specific application requirements.

Note: The touchless infrared position and gesture detection implemented in the example is patent pending.

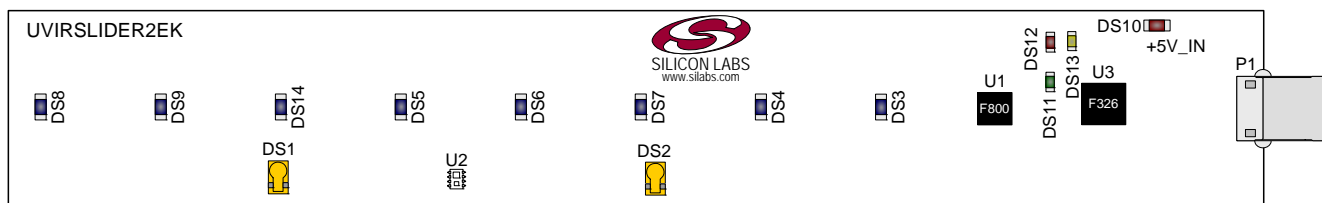

Figure 1. Si1146 Slider Demo Board

Si1146 UVIRSlider2EK

3. Running the Pre-Loaded UV Index Demo

1. The board receives its power over the USB interface. Connect one end of a USB cable to the USB connector (P1) on the Si1146 UVIRSlider2EK Demo Board and the other end to a USB Port on the PC.
2. The red LED DS10 should light on the board, indicating that it is receiving power from the USB.
3. The visible blue LEDs will light according to the perceived UV Index of the environment above the board.
4. See Table 1 on page 2 for a description on what the number of blue LEDs illuminated represents.

Table 1. UV Demo Output Description

# Blue LEDs	UV Index	UV Index Description
5	11+	Extreme
4	8,9,10	Very High
3	6,7	High
2	3,4,5	Moderate
1	1,2	Low

4. Software Overview

The UVIRSLIDER2EK is supported by the UVIRSLIDER Demo application and the Si114x Programmer's Toolkit. The software can be downloaded from the web at: <http://www.silabs.com/products/sensors/pages/optical-sensor-software.aspx>.

The UVIRSLIDER Demo application allows the user to select the UV Index demo, the IR Slider demo, or the UDP Waveform Viewer. The UV demo includes a GUI that displays the full 11+ UV Index value and the 5-level UV sun exposure level. The IRSLIDER demo tracks the movement of your hand over the 8 LEDs on the board using proximity to sense the position of your hand. The IRSLIDER demo can also detect hand gestures as described in Table 2. The UDP Waveform Viewer allows users to see real-time infrared proximity and ambient light measurements from the Si1146 in a graphical form.

The Si114x Programmer's Toolkit API enables rapid development of Si114x software in a PC environment using the Si1146 UVIRSlider2EK Demo Board. The Si114x Programmer's Toolkit contains example source code that allows developers to get started quickly and then tailor the code to their needs. In addition, the Silicon Labs Integrated Development Environment (IDE) provides a means of developing code for the C8051F800 and uses the USB connection on the board to program the MCU and perform in-system debugging.

4.1. Using the UVIRSlider2EK Demo Board with the UVIRSLIDER Demo Application

The Si1146 UVIRSlider2EK Demo Board is supported by the UVIRSLIDER Demo application. The UVIRSLIDER Demo application allows the user to run the UV Index or IR Slider demos as well as launch the UDP Waveform Viewer. The UDP Waveform Viewer allows users to see real-time infrared proximity and ambient light measurements from the Si1146 in a graphical form. The communications interface to the Si1146 UVIRSlider2EK Demo Board is provided over the USB connection.

To use the UVIRSLIDER Demo with the Si1146 UVIRSlider2EK Demo Board, perform the following steps:

1. Connect the Si1146 UVIRSlider2EK Demo Board to the PC using a USB cable.
2. Launch the UVIRSLIDER Demo. If you do not have this application, it is available for download at the link provided at the beginning of the Software Overview description.
3. Select the desired demo from the Main Menu.
4. Follow the instructions on the screen for how to use the demo.
5. The UDP Waveform Viewer can be launched by pressing on the Waveform Viewer button on the demo

application screen.

Note: The the Si114x Programmer's Toolkit, and the IDE cannot connect to the Si1146 UVIRSlider2EK Demo Board at the same time. Be certain to disconnect from the board in one software package before trying to connect in the other.

Figure 2 shows an example of the UVIRSLIDER Demo main window when connected to the Si1146 UVIRSlider2EK Demo Board.



Figure 2. UVIRSLIDER Demo Main Window

Table 2. Recognized Gestures

Gesture Name	Parameter	Description of Action and LED Indication
Pause	Position	Hold hand steady in a single position above the board for 3/4 second. Current position LED will blink briefly.
Swipe Left	Speed	Move hand rapidly from the right side to the left side of the board. LEDs will briefly indicate a leftward sweep pattern.
Swipe Right	Speed	Move hand rapidly from the left side to the right side of the board. LEDs will briefly indicate a rightward sweep pattern.

Si1146 UVIRSlider2EK

4.2. Si114x Programmer's Toolkit

4.2.1. Software API

The Si114x Programmer's Toolkit API enables rapid development of Si114x software in a PC environment using the Si1146 UVIRSlider2EK Demo Board. By emulating an I²C interface over USB, the Si114x Programmer's Toolkit API allows source code to be developed on a PC and then migrated quickly and easily to an MCU environment once target hardware is available. Either commercially-available or free PC-based C compilers can be used for software development with the Si114x Programmer's Toolkit API.

The Si114x Programmer's Toolkit API also includes the Si114x UDP Waveform Viewer Application. This tool runs in conjunction with user applications to display and debug the measurements taken from the Si1146 UVIRSlider2EK Demo Board.

Note: The Si114x Programmer's Toolkit and IDE cannot connect to the Si1146 UVIRSlider2EK Demo Board at the same time. Be certain to disconnect from the board in one software package before trying to connect in the other.

4.2.2. Command Line Utilities

For evaluation of the Si1146 UVIRSlider2EK Demo Board without the need to develop and compile source code, a flexible set of command line utilities is also provided with the Si114x Programmer's Toolkit. These utilities can be used to configure and read samples from the Si1146 UVIRSlider2EK Demo Board. For automated configuration and scripting, the command line utilities can be embedded into .bat files.

4.2.3. Sample Source Code

For faster application development, the Si114x Programmer's Toolkit contains example source code for the Si1146 UVIRSlider2EK Demo Board and for each of the command line utilities. Developers can get started quickly by using the Si114x example source code and then tailoring it to their needs.

4.2.4. Downloading the Si114x Programmer's Toolkit

The Si114x Programmer's Toolkit and associated documentation is available from the web at the following URL: <http://www.silabs.com/products/sensors/pages/optical-sensor-software.aspx>.

4.3. Silicon Laboratories IDE

The Silicon Laboratories IDE integrates a source-code editor, a source-level debugger, and an in-system Flash programmer. This tool can be used to develop and debug code for the C8051F800 MCU, which is included on the Si1146 UVIRSlider2EK Demo Board. The use of several third-party compilers and assemblers is supported by the IDE.

4.3.1. IDE System Requirements

The Silicon Laboratories IDE requirements are:

- Pentium-class host PC running Microsoft Windows 2000 or newer
- One available USB port

4.3.2. Third Party Toolsets

The Silicon Laboratories IDE has native support for many 8051 compilers. The full list of natively-supported tools is as follows:

- Keil
- IAR
- Raisonance
- Tasking
- SDCC

4.3.3. Downloading the Example Firmware Image

Source code that has been developed and compiled for the C8051F800 MCU on the Si1146 UVIRSlider2EK Demo Board may be downloaded to the board using the Silicon Laboratories IDE. Follow the instructions below to update or refresh the .HEX image in the Si1146 UVIRSlider2EK Demo Board.

1. Connect the Si1146 UVIRSlider2EK Demo Board to the PC using a USB cable.
2. Launch the Silicon Labs IDE, and click on *Options->Connection Options*.
3. Select "USB Debug Adapter", and then select the board from the list (it should show up as "TS" followed by a serial number).
4. Select "C2" as the debug interface, and press "OK".
5. Connect to the board by pressing the "Connect" icon, or using the keyboard shortcut Alt+C.
6. Click on the "Download" icon, or use the keyboard shortcut Alt+D.
7. In the download dialog window, click "Browse".
8. Change to Files of Type "Intel Hex (*.hex)" and then browse to select the file.
9. Click "Open" then "Download".
10. To run the new image, either press "Run" or "Disconnect" in the IDE.

Note: The Si114x Programmer's Toolkit and the IDE cannot connect to the Si1146 UVIRSlider2EK Demo Board at the same time. Be certain to disconnect from the board in one software package before trying to connect in the other.

Si1146 UVIRSlider2EK

5. Schematic

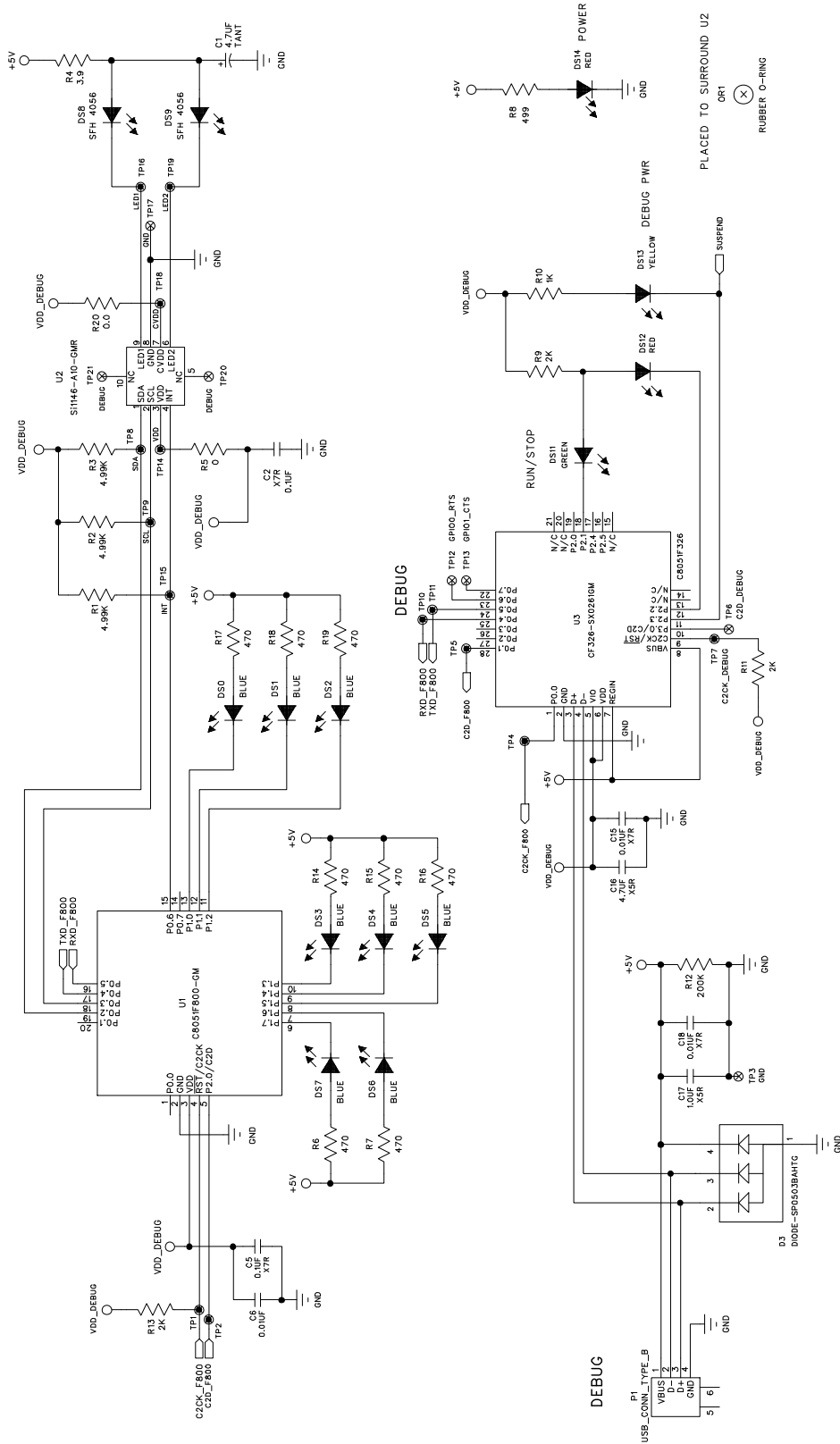

Figure 3. Si1146 UVIRSlider2EK Demo Board Schematic

CONTACT INFORMATION

Silicon Laboratories Inc.

400 West Cesar Chavez

Austin, TX 78701

Tel: 1+(512) 416-8500

Fax: 1+(512) 416-9669

Toll Free: 1+(877) 444-3032

Please visit the Silicon Labs Technical Support web page:

<https://www.siliconlabs.com/support/pages/contacttechnicalsupport.aspx>

and register to submit a technical support request.

Patent Notice

Silicon Labs invests in research and development to help our customers differentiate in the market with innovative low-power, small size, analog-intensive mixed-signal solutions. Silicon Labs' extensive patent portfolio is a testament to our unique approach and world-class engineering team.

The information in this document is believed to be accurate in all respects at the time of publication but is subject to change without notice. Silicon Laboratories assumes no responsibility for errors and omissions, and disclaims responsibility for any consequences resulting from the use of information included herein. Additionally, Silicon Laboratories assumes no responsibility for the functioning of undescribed features or parameters. Silicon Laboratories reserves the right to make changes without further notice. Silicon Laboratories makes no warranty, representation or guarantee regarding the suitability of its products for any particular purpose, nor does Silicon Laboratories assume any liability arising out of the application or use of any product or circuit, and specifically disclaims any and all liability, including without limitation consequential or incidental damages. Silicon Laboratories products are not designed, intended, or authorized for use in applications intended to support or sustain life, or for any other application in which the failure of the Silicon Laboratories product could create a situation where personal injury or death may occur. Should Buyer purchase or use Silicon Laboratories products for any such unintended or unauthorized application, Buyer shall indemnify and hold Silicon Laboratories harmless against all claims and damages.

Silicon Laboratories and Silicon Labs are trademarks of Silicon Laboratories Inc.

Other products or brandnames mentioned herein are trademarks or registered trademarks of their respective holders.



Компания «ЭлектроПласт» предлагает заключение долгосрочных отношений при поставках импортных электронных компонентов на взаимовыгодных условиях!

Наши преимущества:

- Оперативные поставки широкого спектра электронных компонентов отечественного и импортного производства напрямую от производителей и с крупнейших мировых складов;
- Поставка более 17-ти миллионов наименований электронных компонентов;
- Поставка сложных, дефицитных, либо снятых с производства позиций;
- Оперативные сроки поставки под заказ (от 5 рабочих дней);
- Экспресс доставка в любую точку России;
- Техническая поддержка проекта, помощь в подборе аналогов, поставка прототипов;
- Система менеджмента качества сертифицирована по Международному стандарту ISO 9001;
- Лицензия ФСБ на осуществление работ с использованием сведений, составляющих государственную тайну;
- Поставка специализированных компонентов (Xilinx, Altera, Analog Devices, Intersil, Interpoint, Microsemi, Aeroflex, Peregrine, Syfer, Eurofarad, Texas Instrument, Miteq, Cobham, E2V, MA-COM, Hittite, Mini-Circuits, General Dynamics и др.);

Помимо этого, одним из направлений компании «ЭлектроПласт» является направление «Источники питания». Мы предлагаем Вам помощь Конструкторского отдела:

- Подбор оптимального решения, техническое обоснование при выборе компонента;
- Подбор аналогов;
- Консультации по применению компонента;
- Поставка образцов и прототипов;
- Техническая поддержка проекта;
- Защита от снятия компонента с производства.



Как с нами связаться

Телефон: 8 (812) 309 58 32 (многоканальный)

Факс: 8 (812) 320-02-42

Электронная почта: org@eplast1.ru

Адрес: 198099, г. Санкт-Петербург, ул. Калинина, дом 2, корпус 4, литера А.