

PLUG HOUSING

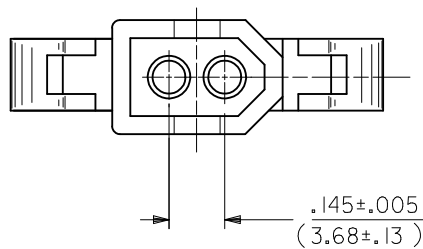
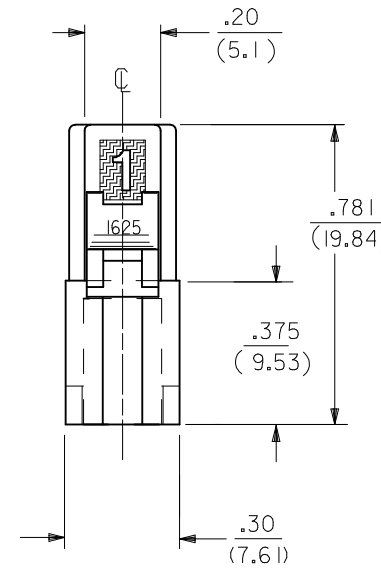
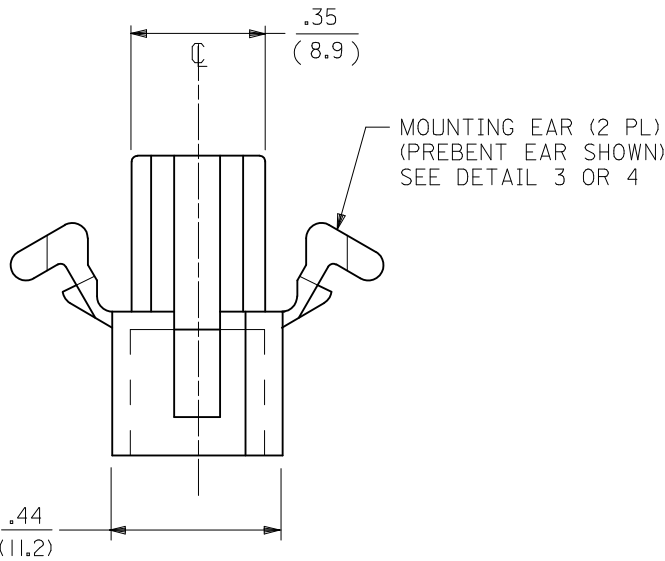
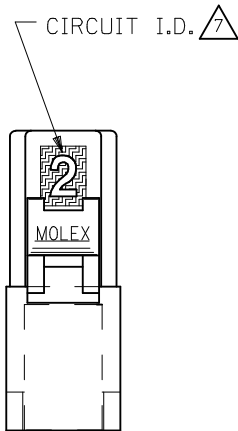

3	AF
2	AF
1	AF
SHT. REV.	

UPDATE REV. LEVEL EC NO: UCP2012-2714 DRW: AELHAG CHKD: JEBLL APPR: FSMITH 2012/04/10 2012/04/10 2012/04/25	QUALITY SYMBOLS ▽=0 ▽=0	GENERAL TOLERANCES (UNLESS SPECIFIED)		DIMENSION STYLE IN/MM	SCALE 4:1	DESIGN UNITS INCH	THIRD ANGLE PROJECTION
		4 PLACES ± --- ± --- 3 PLACES ± --- ± .007 2 PLACES ± 0.18 ± .010 1 PLACE ± 0.25 ± ---	DRAWN BY JJS	DATE 1988/04/13	TITLE PLUG AND RECEPTACLE 2 CIRCUIT HOUSINGS .062/(1.57) DIA.		
		ANGULAR ± 1°	CHECKED BY RW	DATE 1988/04/13	MOLEX MOLEX INCORPORATED		
		DRAFT WHERE APPLICABLE MUST REMAIN WITHIN DIMENSIONS	APPROVED BY RAS	DATE 1988/04/13	MATERIAL NO. SEE CHART	DOCUMENT NO. SD-1625-2*	SHEET NO. 1 OF 3

PLUG	
PART NO.	ENG. NO.
03-06-7023	I625-2P1BK
03-06-2023	I625-2P1
03-06-7027	I625-2P2BK
03-06-2024	I625-2P2

RECEPTACLE		
PART NO.	ENG. NO.	
03-06-6023	I625-2R1BK	
03-06-1020	I625-2R3	OBSOLETE
03-06-1023	I625-2R1	
03-06-1022	I625-2R2	
03-06-6025	I625-2R2RD	OBSOLETE
03-06-6026	I625-2R2GN	OBSOLETE
03-06-6027	I625-2R2BU	OBSOLETE
03-06-6022	I625-2R2BK	OBSOLETE
03-06-6028	I625-2R1BU	OBSOLETE

RECEPTACLE LEGEND:

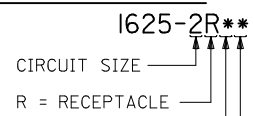

BLANK = WITH STANDARD MOUNTING EARS; WITH DETENTS
 1 = WITHOUT MOUNTING EARS; WITH DETENTS
 2 = WITH PREBENT MOUNTING EARS; WITH DETENTS
 3 = W/O MOUNTING EARS, WITH POSITIVE LOCK

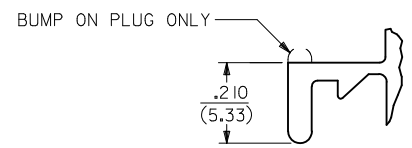

PLUG LEGEND:



1 = WITHOUT MOUNTING EARS
 2 = WITH PREBENT MOUNTING EARS
 3 = W/O MOUNTING EARS, WITH POSITIVE LOCK

BLANK = NATURAL
 AM=AMBER BK=BLACK BU=BLUE
 BN=BROWN GY=GRAY GN=GREEN
 OR=ORANGE RD=RED YW=YELLOW

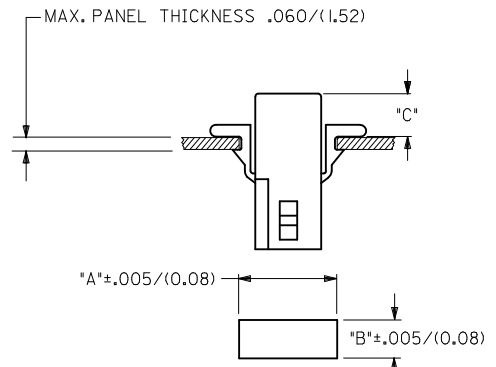

RECOMMENDED HOLE PATTERN

HOUSING	DIM. "A"	DIM. "B"	PREBENT EAR DIM. "C"	STD. EAR DIM. "C"
PLUG	.609 (15.47)	.318 (8.08)	.24 (6.0)	.24 (6.1)
RECEPTACLE	.505 (12.83)	.265 (6.73)	.25 (6.4)	.25 (6.4)

DETAIL 3

STANDARD MOUNTING EARS
(SCALE 4:1)

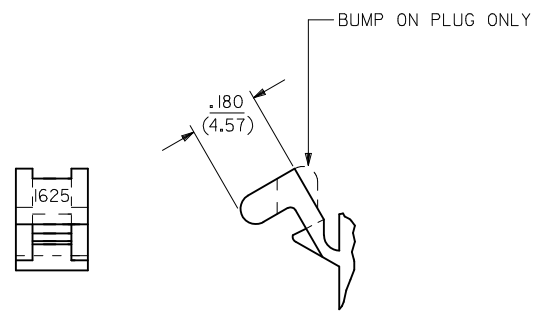

DETAIL 4

PREBENT MOUNTING EARS
(SCALE 4:1)

- NOTES:
- MATERIAL - NYLON TYPE 6/6, 94V-2
 - FINISH: NONE
 - PRODUCT SPECIFICATION: PS-02-06
 - PACKAGING SPECIFICATION: PK-1625-003.
 - POSITIVE LOCK VERSION REQUIRES USE OF A SCREWDRIVER OR SIMILAR TOOL TO LIFT SHROUD ON PLUG HOUSING IN ORDER TO UNMATE RECEPTACLE HOUSINGS
 - HOUSINGS FOR USE WITH MOLEX .062/(1.57) DIA. SERIES TERMINALS.
 - CIRCUIT I.D. NUMBERS ON SIDE OF HOUSING APPEAR ON PARTS FROM TOOLS BUILT AFTER 07/01/1991.
 - THIS PART CONFORMS TO CLASS B REQUIREMENTS OF COSMETIC SPECIFICATION PS-45499-002.

REVISE PKG (NOTE 4) EC NO: UCP2012-2714 DRWNAELHAG 2012/04/10 CHKD:JBELL 2012/04/10 APPR:FSMITH 2012/04/25 AF	QUALITY SYMBOLS ▽=0 ▽=0	GENERAL TOLERANCES (UNLESS SPECIFIED)	DIMENSION STYLE IN/MM	SCALE 2:1	DESIGN UNITS INCH	THIRD ANGLE PROJECTION														
		<table border="1"> <tr> <th></th> <th>mm</th> <th>INCH</th> </tr> <tr> <td>4 PLACES</td> <td>± .005</td> <td>± .0005</td> </tr> <tr> <td>3 PLACES</td> <td>± .007</td> <td>± .0007</td> </tr> <tr> <td>2 PLACES</td> <td>± 0.18</td> <td>± .010</td> </tr> <tr> <td>1 PLACE</td> <td>± 0.25</td> <td>± .010</td> </tr> </table>		mm	INCH	4 PLACES	± .005	± .0005	3 PLACES	± .007	± .0007	2 PLACES	± 0.18	± .010	1 PLACE	± 0.25	± .010	DRAWN BY DATE JJS 1988/04/14	TITLE PLUG & RECEPTACLE 2 CIRCUIT HOUSINGS .062(1.57)DIA.	
			mm	INCH																
		4 PLACES	± .005	± .0005																
3 PLACES	± .007	± .0007																		
2 PLACES	± 0.18	± .010																		
1 PLACE	± 0.25	± .010																		
ANGULAR ± 1°	CHECKED BY DATE RW 1988/04/14	MOLEX MOLEX INCORPORATED																		
DRAFT WHERE APPLICABLE MUST REMAIN WITHIN DIMENSIONS	APPROVED BY DATE RAS 1988/04/14	MATERIAL NO. SEE CHART	DOCUMENT NO. SD-1625-2*	SHEET NO. 3 OF 3																



Компания «ЭлектроПласт» предлагает заключение долгосрочных отношений при поставках импортных электронных компонентов на взаимовыгодных условиях!

Наши преимущества:

- Оперативные поставки широкого спектра электронных компонентов отечественного и импортного производства напрямую от производителей и с крупнейших мировых складов;
- Поставка более 17-ти миллионов наименований электронных компонентов;
- Поставка сложных, дефицитных, либо снятых с производства позиций;
- Оперативные сроки поставки под заказ (от 5 рабочих дней);
- Экспресс доставка в любую точку России;
- Техническая поддержка проекта, помощь в подборе аналогов, поставка прототипов;
- Система менеджмента качества сертифицирована по Международному стандарту ISO 9001;
- Лицензия ФСБ на осуществление работ с использованием сведений, составляющих государственную тайну;
- Поставка специализированных компонентов (Xilinx, Altera, Analog Devices, Intersil, Interpoint, Microsemi, Aeroflex, Peregrine, Syfer, Eurofarad, Texas Instrument, Miteq, Cobham, E2V, MA-COM, Hittite, Mini-Circuits, General Dynamics и др.);

Помимо этого, одним из направлений компании «ЭлектроПласт» является направление «Источники питания». Мы предлагаем Вам помощь Конструкторского отдела:

- Подбор оптимального решения, техническое обоснование при выборе компонента;
- Подбор аналогов;
- Консультации по применению компонента;
- Поставка образцов и прототипов;
- Техническая поддержка проекта;
- Защита от снятия компонента с производства.



Как с нами связаться

Телефон: 8 (812) 309 58 32 (многоканальный)

Факс: 8 (812) 320-02-42

Электронная почта: org@eplast1.ru

Адрес: 198099, г. Санкт-Петербург, ул. Калинина, дом 2, корпус 4, литера А.