

Wide-band, directional coupler with integrated 50 ohm loaded isolated port

Datasheet – production data

Features

- 50 Ω nominal input / output impedance
- Wide operating frequency range (2400 MHz to 5850 MHz)
- Low insertion loss
- Coupling factor:
 - 18 dB at 2.4 GHz
 - 12 dB at 5 GHz
- High ESD robustness
- Packaged in Flip Chip
- Package thickness: < 595 μm after reflow
- Small footprint

Benefits

- Very low profile
- Lead-free package
- High RF performance
- RF module size reduction

Applications

- Quad-band power amplifier module
- Quad-band front end module
- WLAN

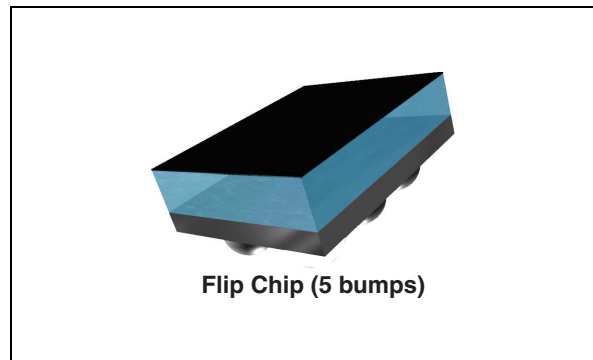
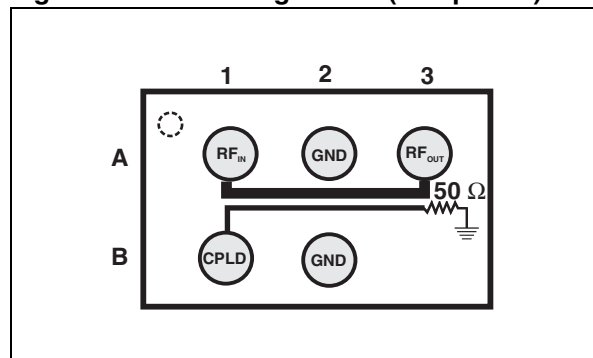

Figure 1. Pin configuration (bump view)



Description

The CPL-WB-02D3 is a wide-band directional coupler designed to measure RF antenna output power. This CPL has been customized for wide band operating frequencies (2G/5G WLAN) with low insertion losses in the transmit bandwidth (2400 MHz to 5850 MHz).

The CPL-WB-02D3 has been designed using STMicroelectronics IPD (integrated passive device) technology on non-conductive glass substrate to optimize RF performance. The device is delivered 100% tested in tape and reel.

1 Characteristics

Table 1. Absolute maximum rating (limiting values)

Symbol	Parameter	Value			Unit
		Min.	Typ.	Max.	
P_{IN}	Input power RF_{IN}			25	dBm
$V_{ESD (HBM)}$	Human body model, JESD22-A114-B, All I/O	2			kV
$V_{ESD (MM)}$	Machine model, JESD22-A115-A, All I/O	100			V
$V_{ESD (CDM)}$	Charge device model, JESD22-C101-C, All I/O	500			V
T_{OP}	Operating temperature	-30		+85	°C

Table 2. Electrical characteristics ($T_{amb} = 25\text{ °C}$) - impedances

Symbol	Parameter	Value			Unit
		Min.	Typ.	Max.	
Z_{OUT}	Nominal output impedance		50		Ω
Z_{IN}	Nominal input impedance		50		Ω
Z_{CPLD}	Nominal coupling impedance		50		Ω

Table 3. Electrical characteristics ($T_{amb} = 25\text{ °C}$) - RF performance

Symbol	Parameter	Test condition	Value			Unit
			Min.	Typ.	Max.	
T_{OP}	Operating temperature		-30		+85	°C
f	Frequency range (bandwidth)		2400		5850	MHz
I_L	Insertion loss in bandwidth	From 2400 MHz to 2500 MHz			0.2	dB
		From 4900 MHz to 5850 MHz			0.5	
R_L	Return loss in bandwidth (IN, OUT pins)	From 2400 MHz to 5850 MHz	15			dB
CPLD	Coupling factor	From 2400 MHz to 2500 MHz	17	18	19	dB
		From 4900 MHz to 5850 MHz	11	12	13	dB

2 PCB recommendation

Figure 2. Recommended land pattern

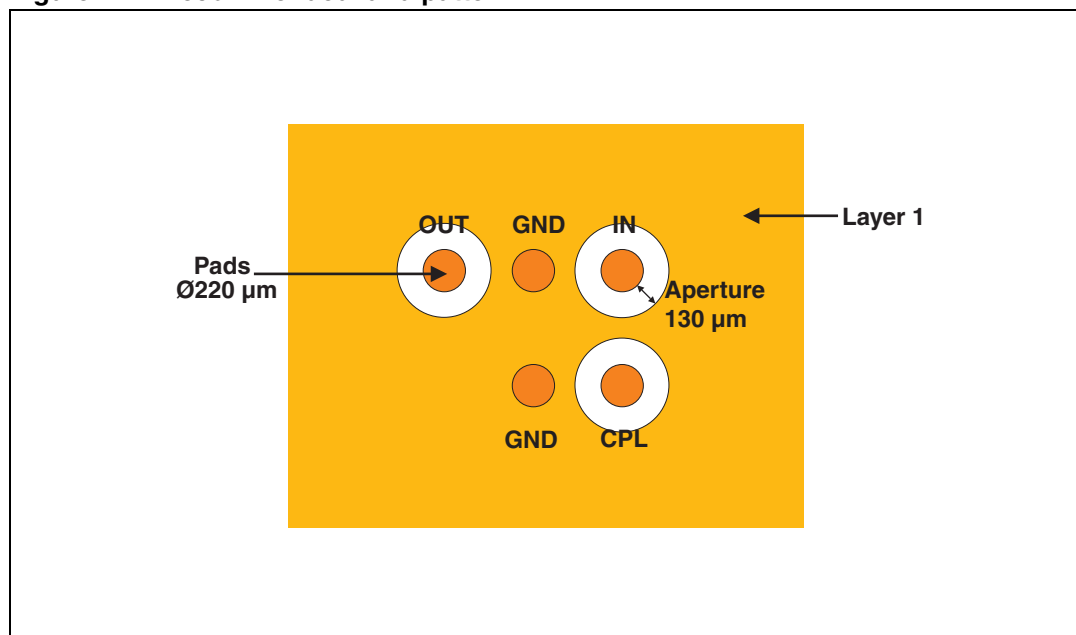

3 Package information

In order to meet environmental requirements, ST offers these devices in different grades of ECOPACK® packages, depending on their level of environmental compliance. ECOPACK® specifications, grade definitions and product status are available at: www.st.com. ECOPACK® is an ST trademark.

Figure 3. Package dimensions

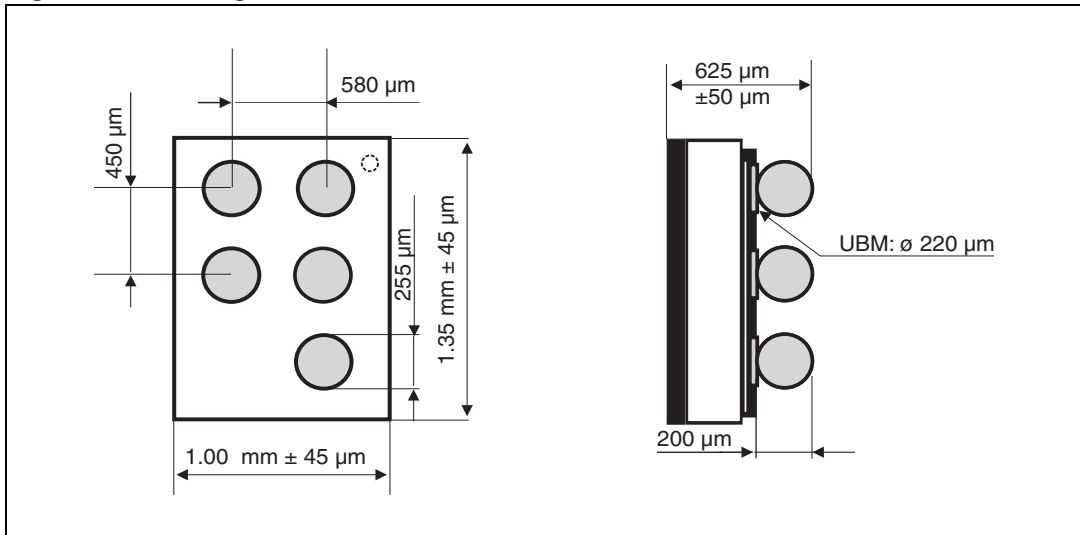

Figure 4. Footprint

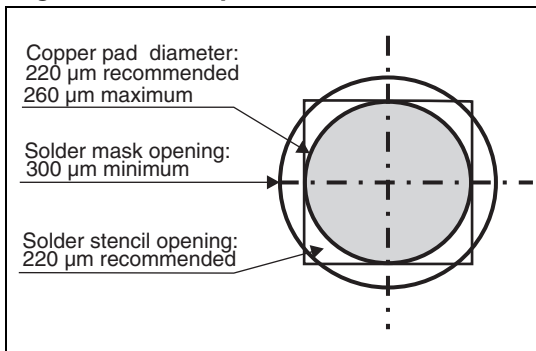

Figure 5. Marking

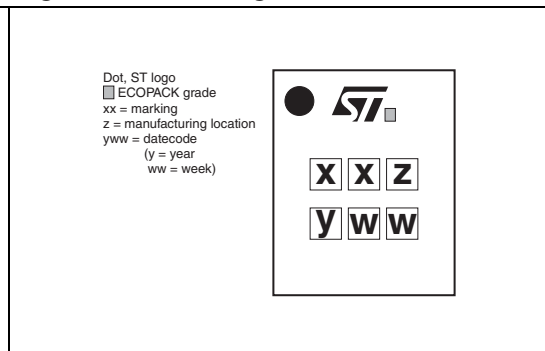
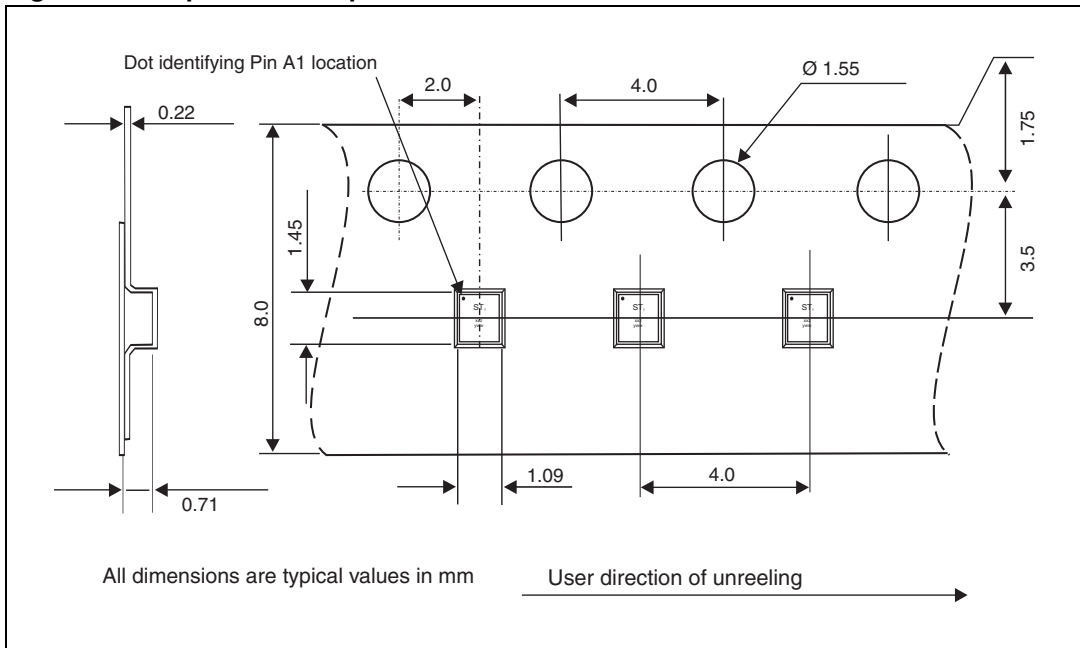

Figure 6. Tape and reel specifications



Note: More information is available in the STMicroelectronics Application note:
AN2348, "IPAD™ 400 μm Flip Chip: package description and recommendations for use"
AN1751: "EMI Filters: recommendations and measurements"

4 Ordering information

Table 4. Ordering information

Order code	Marking	Package	Weight	Base qty	Delivery mode
CPL-WB-02D3	SE	Flip Chip	1.59 mg	5000	Tape and reel

5 Revision history

Table 5. Document revision history

Date	Revision	Changes
18-Jun-2012	1	Initial release

Please Read Carefully:

Information in this document is provided solely in connection with ST products. STMicroelectronics NV and its subsidiaries ("ST") reserve the right to make changes, corrections, modifications or improvements, to this document, and the products and services described herein at any time, without notice.

All ST products are sold pursuant to ST's terms and conditions of sale.

Purchasers are solely responsible for the choice, selection and use of the ST products and services described herein, and ST assumes no liability whatsoever relating to the choice, selection or use of the ST products and services described herein.

No license, express or implied, by estoppel or otherwise, to any intellectual property rights is granted under this document. If any part of this document refers to any third party products or services it shall not be deemed a license grant by ST for the use of such third party products or services, or any intellectual property contained therein or considered as a warranty covering the use in any manner whatsoever of such third party products or services or any intellectual property contained therein.

UNLESS OTHERWISE SET FORTH IN ST'S TERMS AND CONDITIONS OF SALE ST DISCLAIMS ANY EXPRESS OR IMPLIED WARRANTY WITH RESPECT TO THE USE AND/OR SALE OF ST PRODUCTS INCLUDING WITHOUT LIMITATION IMPLIED WARRANTIES OF MERCHANTABILITY, FITNESS FOR A PARTICULAR PURPOSE (AND THEIR EQUIVALENTS UNDER THE LAWS OF ANY JURISDICTION), OR INFRINGEMENT OF ANY PATENT, COPYRIGHT OR OTHER INTELLECTUAL PROPERTY RIGHT.

UNLESS EXPRESSLY APPROVED IN WRITING BY TWO AUTHORIZED ST REPRESENTATIVES, ST PRODUCTS ARE NOT RECOMMENDED, AUTHORIZED OR WARRANTED FOR USE IN MILITARY, AIR CRAFT, SPACE, LIFE SAVING, OR LIFE SUSTAINING APPLICATIONS, NOR IN PRODUCTS OR SYSTEMS WHERE FAILURE OR MALFUNCTION MAY RESULT IN PERSONAL INJURY, DEATH, OR SEVERE PROPERTY OR ENVIRONMENTAL DAMAGE. ST PRODUCTS WHICH ARE NOT SPECIFIED AS "AUTOMOTIVE GRADE" MAY ONLY BE USED IN AUTOMOTIVE APPLICATIONS AT USER'S OWN RISK.

Resale of ST products with provisions different from the statements and/or technical features set forth in this document shall immediately void any warranty granted by ST for the ST product or service described herein and shall not create or extend in any manner whatsoever, any liability of ST.

ST and the ST logo are trademarks or registered trademarks of ST in various countries.

Information in this document supersedes and replaces all information previously supplied.

The ST logo is a registered trademark of STMicroelectronics. All other names are the property of their respective owners.

© 2012 STMicroelectronics - All rights reserved

STMicroelectronics group of companies

Australia - Belgium - Brazil - Canada - China - Czech Republic - Finland - France - Germany - Hong Kong - India - Israel - Italy - Japan - Malaysia - Malta - Morocco - Philippines - Singapore - Spain - Sweden - Switzerland - United Kingdom - United States of America

www.st.com





Компания «ЭлектроПласт» предлагает заключение долгосрочных отношений при поставках импортных электронных компонентов на взаимовыгодных условиях!

Наши преимущества:

- Оперативные поставки широкого спектра электронных компонентов отечественного и импортного производства напрямую от производителей и с крупнейших мировых складов;
- Поставка более 17-ти миллионов наименований электронных компонентов;
- Поставка сложных, дефицитных, либо снятых с производства позиций;
- Оперативные сроки поставки под заказ (от 5 рабочих дней);
- Экспресс доставка в любую точку России;
- Техническая поддержка проекта, помощь в подборе аналогов, поставка прототипов;
- Система менеджмента качества сертифицирована по Международному стандарту ISO 9001;
- Лицензия ФСБ на осуществление работ с использованием сведений, составляющих государственную тайну;
- Поставка специализированных компонентов (Xilinx, Altera, Analog Devices, Intersil, Interpoint, Microsemi, Aeroflex, Peregrine, Syfer, Eurofarad, Texas Instrument, Miteq, Cobham, E2V, MA-COM, Hittite, Mini-Circuits, General Dynamics и др.);

Помимо этого, одним из направлений компании «ЭлектроПласт» является направление «Источники питания». Мы предлагаем Вам помощь Конструкторского отдела:

- Подбор оптимального решения, техническое обоснование при выборе компонента;
- Подбор аналогов;
- Консультации по применению компонента;
- Поставка образцов и прототипов;
- Техническая поддержка проекта;
- Защита от снятия компонента с производства.



Как с нами связаться

Телефон: 8 (812) 309 58 32 (многоканальный)

Факс: 8 (812) 320-02-42

Электронная почта: org@eplast1.ru

Адрес: 198099, г. Санкт-Петербург, ул. Калинина, дом 2, корпус 4, литера А.