

## Type 4X Polyester Junction Box (Solid and Clear Cover) *PJU Series*

Lift-Off Cover with Screws



### Application

- Designed for use as instrument enclosures, electric, hydraulic or pneumatic control housings, electrical junction boxes or terminal wiring enclosures.
- Provides outstanding insulation and protection where equipment may be hosed down or be very wet.
- Ideal in applications with high temperatures or highly corrosive environments.

### Standards

- UL 508 Type 1, 2, 3, 4, 4X, 12 and 13
- CSA Type 1, 2, 3, 4, 4X, 12 and 13
- Complies with
  - NEMA Type 1, 2, 3, 4, 4X, 12 and 13
  - IEC 60529, IP66

### Construction

- Molded fiberglass polyester enclosure with matching cover is easily punched, cut, or drilled.
- Enhanced UV inhibitors protect against outdoor weathering.
- Standard JIC sizes under 18" x 16".
- Threaded brass inserts are provided for optional inner panel or terminal kit mounting. Mounting hardware is included.
- Cover fastened with captive stainless steel screws in threaded brass inserts.
- Enclosure available with clear Polycarbonate cover to 16" x 14".
- Captive oil resistant gasket provides a positive seal.
- Available with Polycarbonate flange or foot mount brackets for multi-directional mounting.
- Operating temperatures between 130°C and -40°C (266°F to -40°F).
- Impact index of 6.78J (5 ft/lb).
- For corrosion resistance information, please refer to table in the Technical Information section.

### Finish

- Fiberglass polyester material has a gray finish.
- Optional inner panels are available in white powder coated finished steel or unfinished aluminum, or Fiberglass.

### Accessories

- [Additional Inner Panels](#)
- [Terminal Kit Assemblies](#)
- [Swing Panels](#)

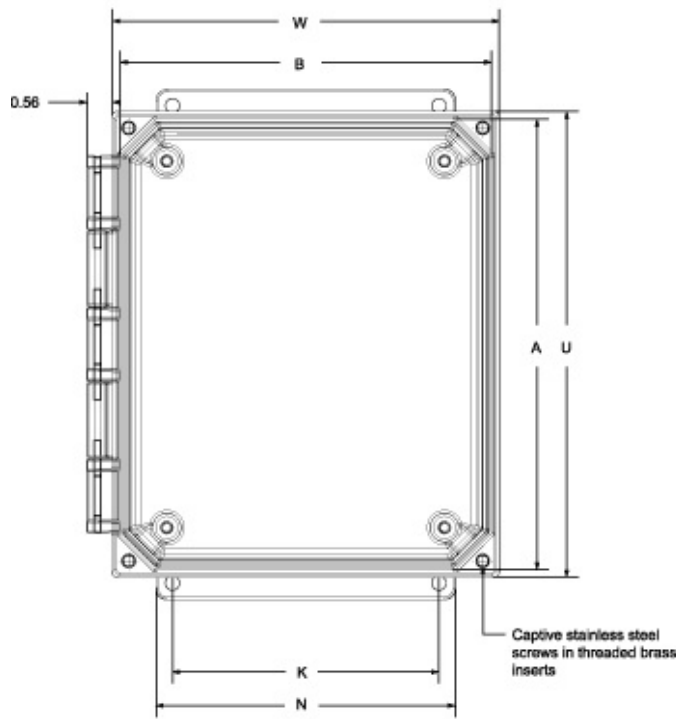

**Front View**

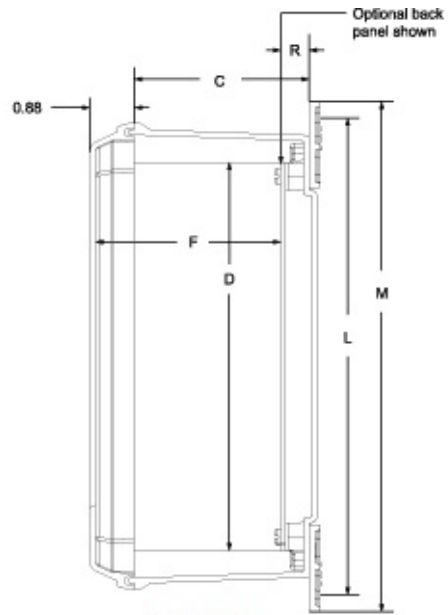

**Side View**

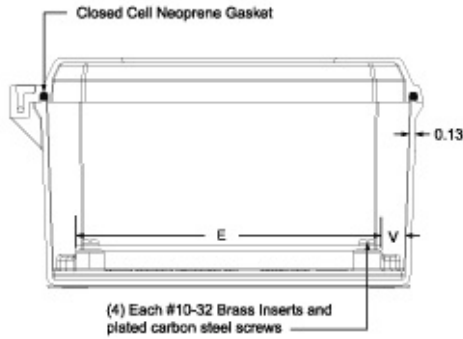

**End View**

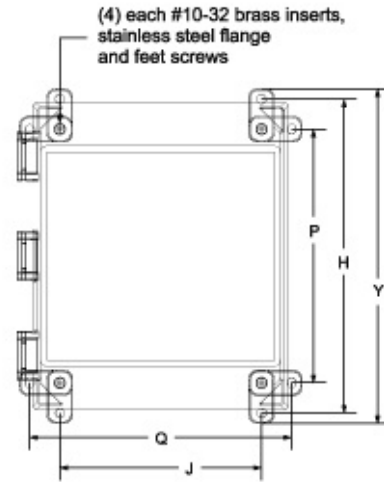

**Rear View**

Lift-Off Cover Flange Part No.	Lift-Off Cover Feet Part No.	Overall Dimensions			Panel Size			Center		Flange Mounting Centers		
		A	B	C	D	E	F	S	Z	L	K	M
PJU664F <sup>1</sup>	PJU664 <sup>1</sup>	6.05	6.27	4.13	4.88	4.88	4.11	4.25	4.25	6.88 / 6.75	4.05	7.62
PJU864F <sup>1</sup>	PJU864 <sup>1</sup>	8.05	6.27	4.13	6.75	4.88	4.11	6.25	4.25	8.88 / 8.75	4.00	9.62
PJU1084F <sup>1</sup>	PJU1084 <sup>1</sup>	10.05	8.27	4.13	8.75	6.88	4.11	10.25	6.25	10.75	6.00	11.50
PJU12106F <sup>1</sup>	PJU12106 <sup>1</sup>	12.05	10.27	6.13	10.75	8.88	6.11	10.25	8.25	12.75	8.00	13.50
PJU14126F <sup>1</sup>	PJU14126 <sup>1</sup>	14.05	12.27	6.13	12.75	10.88	6.11	12.25	10.25	14.75 / 14.62	10.00	15.37
PJU16148F	PJU16148	16.05	14.27	8.13	14.75	12.88	8.11	14.25	12.25	16.75	12.00	17.50
PJU181610F	PJU181610	18.30	16.52	10.13	16.88	14.88	10.11	16.25	14.25	18.88 / 18.76	12.00	20.12
PJU201610F	PJU201610	20.50	16.27	10.13	18.44	14.44	10.11	17.81	13.81	21.25	10.00	21.50

Lift-Off Clear Cover Flange Part No.	Lift-Off Clear Cover Feet Part No.	N	H	J	P	Q	U	W	Y	R	V	Opt. Panel Part No.	Ship Wt. (lbs)
PJU664CCF <sup>1</sup>	PJU664CC <sup>1</sup>	4.80	6.75	4.91	4.69	6.97	6.50	6.72	7.47	0.70	0.52	14R0505	4
PJU864CCF <sup>1</sup>	PJU864CC <sup>1</sup>	4.75	8.75	4.91	6.69	6.97	8.50	6.72	9.46	0.70	0.62	14R0705	4
PJU1084CCF <sup>1</sup>	PJU1084CC <sup>1</sup>	6.75	10.75	6.91	8.69	8.97	10.50	8.72	11.47	0.70	0.53	14R0907	6
PJU12106CCF <sup>1</sup>	PJU12106CC <sup>1</sup>	8.75	12.70	8.82	10.64	10.88	12.50	10.72	13.47	0.68	0.44	14R1109	6
PJU14126CCF <sup>1</sup>	PJU14126CC <sup>1</sup>	10.75	14.70	10.82	12.64	12.88	14.50	12.72	15.37	0.70	0.46	14R1311	8

<b>PJU16148CCF</b>	<b>PJU16148CC</b>	12.75	16.91	11.47	13.50	14.88	16.50	14.72	17.50	0.70	0.40	<b>14R1513</b>	11
-	-	12.75	19.16	13.72	15.75	17.13	18.75	16.97	19.89	0.70	0.45	<b>P1868</b>	12
-	-	12.75	20.53	13.16	17.13	16.56	20.50	16.72	21.28	0.70	0.50	<b>P2068</b>	17

*Data subject to change without notice.*

© 2012. Hammond Manufacturing Ltd. All rights reserved.



Компания «ЭлектроПласт» предлагает заключение долгосрочных отношений при поставках импортных электронных компонентов на взаимовыгодных условиях!

Наши преимущества:

- Оперативные поставки широкого спектра электронных компонентов отечественного и импортного производства напрямую от производителей и с крупнейших мировых складов;
- Поставка более 17-ти миллионов наименований электронных компонентов;
- Поставка сложных, дефицитных, либо снятых с производства позиций;
- Оперативные сроки поставки под заказ (от 5 рабочих дней);
- Экспресс доставка в любую точку России;
- Техническая поддержка проекта, помощь в подборе аналогов, поставка прототипов;
- Система менеджмента качества сертифицирована по Международному стандарту ISO 9001;
- Лицензия ФСБ на осуществление работ с использованием сведений, составляющих государственную тайну;
- Поставка специализированных компонентов (Xilinx, Altera, Analog Devices, Intersil, Interpoint, Microsemi, Aeroflex, Peregrine, Syfer, Eurofarad, Texas Instrument, Miteq, Cobham, E2V, MA-COM, Hittite, Mini-Circuits, General Dynamics и др.);

Помимо этого, одним из направлений компании «ЭлектроПласт» является направление «Источники питания». Мы предлагаем Вам помощь Конструкторского отдела:

- Подбор оптимального решения, техническое обоснование при выборе компонента;
- Подбор аналогов;
- Консультации по применению компонента;
- Поставка образцов и прототипов;
- Техническая поддержка проекта;
- Защита от снятия компонента с производства.



#### Как с нами связаться

**Телефон:** 8 (812) 309 58 32 (многоканальный)

**Факс:** 8 (812) 320-02-42

**Электронная почта:** [org@eplast1.ru](mailto:org@eplast1.ru)

**Адрес:** 198099, г. Санкт-Петербург, ул. Калинина, дом 2, корпус 4, литера А.