

# MLVB

## Multilayer varistor ESD suppressor



Surface Mount Device

### Applications

- Computers and peripherals
- Digital cameras
- Mobile phones
- Medical equipment
- DVD Players
- MP3/Multimedia players
- LCD TV / Monitor
- External storage
- Cable/DSL Modems
- USB 2.0
- Set top boxes

### Product features

- Zinc oxide based ceramic chip
- Low capacitance to meet the need for high speed transient voltage protection
- Provides ESD protection with fast response time (<1ns) allowing equipment to pass IEC 61000-4-2 Level 4 Test
- Low profile designs for board space savings
- Low and stable leakage current reduces power consumption
- Low clamping voltage
- Lead free, halogen free and RoHS compliant for global applications

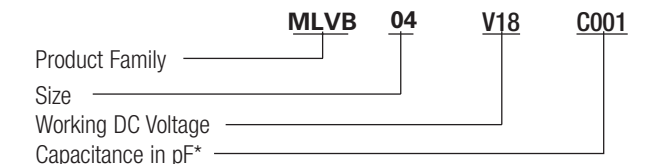

\* Part numbers use "R" to denote decimal point for decimal values of pico farads.

### Packaging

- Size 0402: 10,000 pieces per reel - EIA (EIAJ)
- Size 0603: 4000 pieces per reel - EIA (EIAJ)

Specifications						
Part Number	Size	Working Voltage (Vdc)	Varistor Voltage @1mA <sub>dc</sub>	Clamping Voltage	Capacitance pF	Leakage Current (μA)
MLVB04V18C0R5	0402	18	90-120	250*	0.5	<10
MLVB04V18C001	0402	18	46-60	110*	1	<10
MLVB04V18C003	0402	18	22-34	58	3	<10
MLVB04V09C005	0402	9	11-17	35	5	<10
MLVB06V18C0R5	0603	18	90-120	250*	0.5	<10
MLVB06V18C001	0603	18	46-60	110*	1	<10
MLVB06V18C003	0603	18	22-34	58	3	<10
MLVB06V09C005	0603	9	11-17	35	5	<10

\* Maximum peak voltage across the varistor with 8/20μs waveform and 0.5A pulse current.  
Working Voltage (Vdc) - Maximum DC operating voltage the varistor can maintain and not exceed 10μA leakage current.  
Varistor Voltage - Voltage across the device measured at 1mA DC current. Equivalent to V<sub>B</sub>, "breakdown voltage." Clamping Voltage - Maximum peak voltage across the varistor with 8/20μs waveform and 1A pulse current.  
Capacitance - Device capacitance measured with zero volt bias 1V<sub>rms</sub> at 1MHz.



Powering Business Worldwide

Dimensions - mm

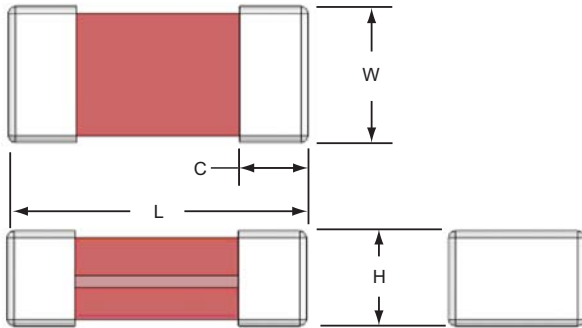

Size	L	W	H	C
0402	1.00±0.15	0.50±0.10	0.50±0.10	0.25±0.15
0603	1.60±0.20	0.80±0.20	0.80±0.20	0.30±0.20

Recommended Pad Layout - mm (in)

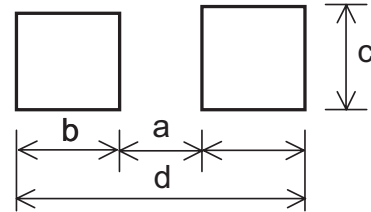

Size	a	b	c	d
0402	0.51 (0.020)	0.61 (0.024)	0.51 (0.020)	1.70 (0.067)
0603	0.50 (0.020)	1.02 (0.040)	0.76 (0.030)	2.54 (0.100)

Tape Packaging Specifications - mm

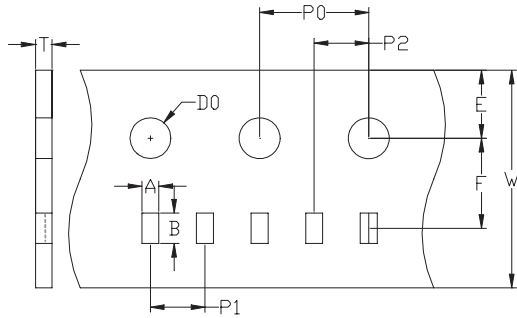

0402 Carrier Dimensions									
A	B	W	E	F	P0	P1	P2	D0	T
0.58 ±0.03	1.2 ±0.03	8.0 ±0.1	1.75 ±0.05	3.5 ±0.05	4.0 ±0.1	2.0 ±0.05	2.0 ±0.05	1.55 ±0.05	0.60 ±0.03
0603 Carrier Dimensions									
0.90 ±0.20	1.80 ±0.20	8.0 ±0.30	1.75 ±0.10	3.50 ±0.05	4.00 ±0.10	-	2.00 ±0.05	1.50 ±0.10	-

Soldering Recommendations

- Compatible with lead and lead-free solder reflow processes
- Peak reflow temperatures and durations:
  - IR Reflow = 260°C max for 30 sec. max.
  - Wave Solder = 260°C max. for 10 sec. max.
- Recommended IR Reflow Profile:

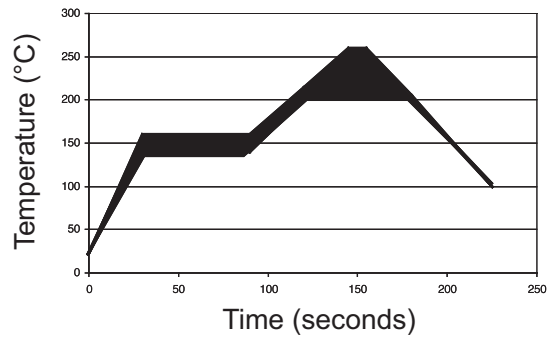

Life Support Policy: Eaton does not authorize the use of any of its products for use in life support devices or systems without the express written approval of an officer of the Company. Life support systems are devices which support or sustain life, and whose failure to perform, when properly used in accordance with instructions for use provided in the labeling, can be reasonably expected to result in significant injury to the user.

Eaton reserves the right, without notice, to change design or construction of any products and to discontinue or limit distribution of any products. Eaton also reserves the right to change or update, without notice, any technical information contained in this bulletin.

**Eaton**  
Electronics Division  
1000 Eaton Boulevard  
Cleveland, OH 44122  
United States  
www.eaton.com/electronics

© 2017 Eaton  
All Rights Reserved Printed in USA  
Publication No. 4071 BU-SB10744  
June 2017

Eaton is a registered trademark.

All other trademarks are property of their respective owners.



Компания «ЭлектроПласт» предлагает заключение долгосрочных отношений при поставках импортных электронных компонентов на взаимовыгодных условиях!

Наши преимущества:

- Оперативные поставки широкого спектра электронных компонентов отечественного и импортного производства напрямую от производителей и с крупнейших мировых складов;
- Поставка более 17-ти миллионов наименований электронных компонентов;
- Поставка сложных, дефицитных, либо снятых с производства позиций;
- Оперативные сроки поставки под заказ (от 5 рабочих дней);
- Экспресс доставка в любую точку России;
- Техническая поддержка проекта, помощь в подборе аналогов, поставка прототипов;
- Система менеджмента качества сертифицирована по Международному стандарту ISO 9001;
- Лицензия ФСБ на осуществление работ с использованием сведений, составляющих государственную тайну;
- Поставка специализированных компонентов (Xilinx, Altera, Analog Devices, Intersil, Interpoint, Microsemi, Aeroflex, Peregrine, Syfer, Eurofarad, Texas Instrument, Miteq, Cobham, E2V, MA-COM, Hittite, Mini-Circuits, General Dynamics и др.);

Помимо этого, одним из направлений компании «ЭлектроПласт» является направление «Источники питания». Мы предлагаем Вам помощь Конструкторского отдела:

- Подбор оптимального решения, техническое обоснование при выборе компонента;
- Подбор аналогов;
- Консультации по применению компонента;
- Поставка образцов и прототипов;
- Техническая поддержка проекта;
- Защита от снятия компонента с производства.



#### Как с нами связаться

**Телефон:** 8 (812) 309 58 32 (многоканальный)

**Факс:** 8 (812) 320-02-42

**Электронная почта:** [org@eplast1.ru](mailto:org@eplast1.ru)

**Адрес:** 198099, г. Санкт-Петербург, ул. Калинина, дом 2, корпус 4, литера А.