

Ordering a market-ready enclosure® is made fast and affordable with our complete in-house capabilities. New Age provides machined openings to fit your PCB, pad printing for your graphics, custom enclosures, custom colors, final assembly, testing and fulfillment services to save you additional time and money. Ask your representative for a free quote today 805-595-1310.

Fast and Affordable Customization

**CNC Modifications
Pad Printing
Colored Resins
EMI/RF Shielding
Custom Enclosure
Assembly & Testing**

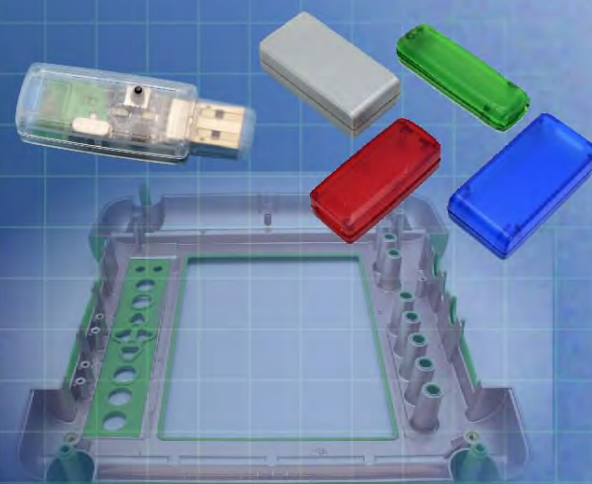

ISO quality
off-the-shelf
to market-ready®

NEW AGE ENCLOSURES

www.NewAgeEnclosures.com

4330 Santa Fe Road • San Luis Obispo, CA 93401 • T 805.595.1310 • F 805.595.1024

NOTES: UNLESS OTHERWISE SPECIFIED

- CORNERS DRAWN SHARP TO BE R.005 MAXIMUM.
- EXTERIOR SURFACE TEXTURE TO BE LIGHT EDM FINISH. EQUIVELANT TO MT-11010.
- INTERIOR SURFACE TEXTURE: NONE.
- ALL INSIDE RADII .010R. ALL OUTSIDE RADII .020R MAX, UNLESS OTHERWISE SPECIFIED.
- ALL EXTERNAL DIMENSIONS AFFECTED BY THE DRAFT APPLY AT THE LARGE END OF THE FEATURE, AND ALL INTERNAL FEATURES AFFECTED BY THE DRAFT APPLY AT THE SMALL END OF THE FEATURE UNLESS OTHERWISE SPECIFIED.
- 1 DEGREE DRAFT IN THE DIRECTION OF PULL IS PERMISSIBLE UNLESS OTHERWISE SPECIFIED.
- MATERIAL / COLOR: ABS PLASTIC IS STANDARD IN BLACK OR WHITE. CUSTOM MATERIALS AND COLORS MAY BE AVAILABLE UPON REQUEST FOR QUOTE.
- PCB SIZES ARE RECOMMENDATIONS ONLY. FINAL SIZES AND VERIFICATION OF IT'S FIT ARE THE SOLE RESPONSIBILITY OF EACH OEM.
- CUSTOM LABEL RECESSES MAY BE AVAILABLE UPON REQUEST FOR QUOTE.
- ASSEMBLY SCREWS PROVIDED. PCB SCREWS AND BATTERY CONTACTS SOLD SEPERATELY.
- ANY SPECIFIC DIMENSIONS NOT PROVIDED HERE CAN BE OBTAINED FROM OUR SOLID MODELS (.STEP), AVAILABLE AT OUR WEBSITE. MODIFIED CUSTOMER MODELS ARE AVAILABLE UPON REQUEST.

| R E V I S I O N | | | | | |
|-----------------|----------|--------|---|-----------|----------|
| REV. | DRAWN BY | ECO No | DESCRIPTION | DATE | APPROVED |
| 1 | M BOYER | --- | RELEASE | 27-Jun-09 | D.C. |
| 3 | M BOYER | 3109 | CONSOLIDATE ALL 442710 CONFIG INTO ONE DOCUMENT | 05-Sep-09 | D.C. |
| 4 | M BOYER | 3809 | INCREASE HATCH RELIEF TOLERANCE | 27-Oct-09 | D.C. |
| 4.1 | M BOYER | 0710 | UPDATE FORMAT | 26-Mar-10 | |

| S442710(x) CONFIGURATIONS | | | | |
|-----------------------------|--------|-----|-----|------|
| | -Blank | -WE | -WP | -LCD |
| S442710 COVER | 1 | 1 | | |
| S442710 COVER W/ LCD CUTOUT | | | | 1 |
| S442710 BATTERY BASE | 1 | 1 | | 1 |
| S442710 WALL BASE | | 1 | 1 | |
| S442710 HATCH | 1 | 1 | | 1 |
| #4 HiLo SCREW 1.00" | | 1 | 1 | |
| #4 HiLo SCREW .750" | 2 | 1 | | 2 |
| #4 HiLo SCREW .500" | 2 | 2 | | 2 |
| SINGLE AA CLIP | 2* | 2* | | 2* |
| DOUBLE AA CLIP | 1* | 1* | | 1* |

* = SOLD SEPERATELY

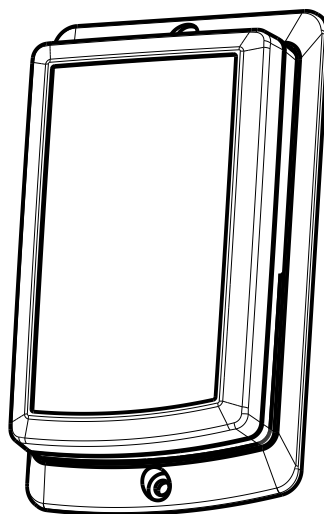

SCALE 0.500

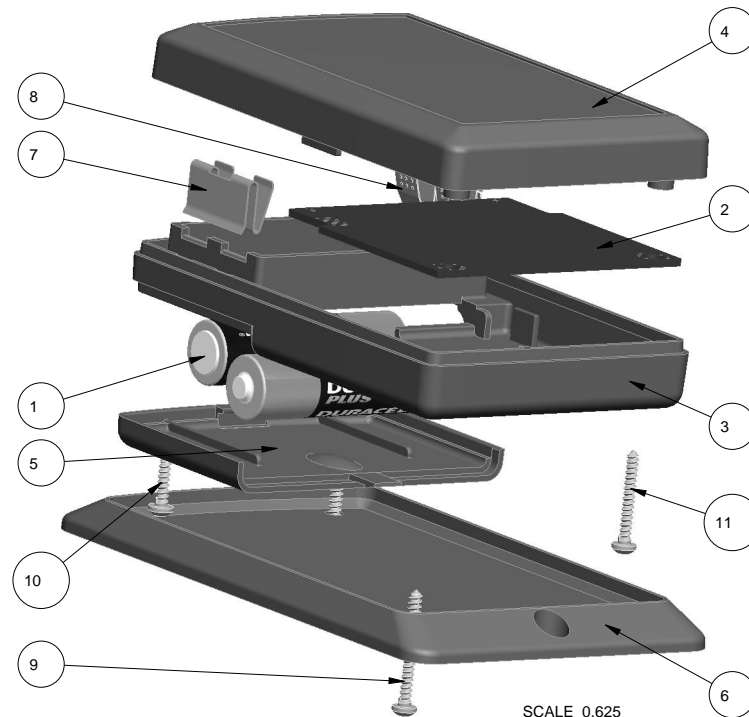

SCALE 0.625

| ITEM | FILE NAME | DESCRIPTION | MATERIAL | COLOR | QTY. |
|------|-----------------|---------------------------|-------------------|----------------|------|
| 11 | NO_4_750_SCREW | HiLo4 x 3/4" | S-HiLo x 3/4" | ZINC PLATED | 1 |
| 10 | NO_4_500_SCREW | HiLo4 x 1/2" | S-HiLo x 1/2" | ZINC PLATED | 1 |
| 9 | NO_4_1000_SCREW | HiLo4 x 1" | S-HiLo x 1.0" | ZINC PLATED | 2 |
| 8 | SM_CLIP | PartNo: 209 | SINGLE AA | NICKEL PLATED | 2 |
| 7 | LG_CLIP | PartNo:210 | DOUBLE AA | NICKEL PLATED | 1 |
| 6 | 442710-WALL | S442710 WALL - STANDARD | ABS | BLACK or WHITE | 1 |
| 5 | 442710-HATCH | S442710E HATCH - STANDARD | ABS | BLACK or WHITE | 1 |
| 4 | 442710-COVER | S442710 COVER - STANDARD | ABS | BLACK or WHITE | 1 |
| 3 | 442710-BASE | S442710 BASE - STANDARD | ABS | BLACK or WHITE | 1 |
| 2 | 442710-PCB | REFERENCE ONLY | CUSTOMER SUPPLIED | .062" THICK | 1 |
| 1 | AA_BATTERY | REFERENCE ONLY | CUSTOMER SUPPLIED | - | 2 |

BILL OF MATERIALS

| <p>THIRD ANGLE PROJECTION</p> <p>DO NOT SCALE DRAWING</p> | <p>TOLERANCES: UNLESS OTHERWISE SPECIFIED DIMENSIONS ARE IN U.S. INCHES:</p> <p>X.XX = .015 X.XXXX = .001 X.XXX = .010 X.X" = 1°</p> | | <p>NEW AGE ENCLOSURES</p> <p>4330 Santa Fe Road San Luis Obispo, CA. 93401 ph. (805) 595-1310 fax (805) 595-1024 www.newageenclosures.com</p> | | | | | | | | | | | | | | | | | | |
|---|---|-------------------|--|--------------------------|------------------------|--|--|------|--|--|-------|--|--|---|----------|----|------|--|--|--|---|
| | <p>Customer's Part No: 442710</p> | | | | | | | | | | | | | | | | | | | | |
| <p>NOTICE: THE INFORMATION AND DATA CONTAINED HEREIN IS CONSIDERED PROPRIETARY TO ALLTEC INTEGRATED MFG INC & SHALL REMAIN THE EXCLUSIVE PROPERTY OF ALLTEC INTEGRATED MFG INC THE HOLDER WILL ASSUME CUSTODY AND CONTROL THAT THIS DOCUMENT WILL NOT BE COPIED, REPRODUCED, OR DISCLOSED WITHOUT THE EXPRESS WRITTEN CONSENT OF ALLTEC INTEGRATED MFG INC POSSESSION OF THIS DOCUMENT DOES NOT CONSTITUTE A GRANT TO MANUFACTURE ANY ITEMS.</p> <p>©2010</p> | <table border="1"> <tr> <th>APPROVAL</th> <th>BY</th> <th>DATE</th> </tr> <tr> <td>CHECK</td> <td></td> <td></td> </tr> <tr> <td>ENG.</td> <td></td> <td></td> </tr> <tr> <td>SCALE</td> <td></td> <td></td> </tr> </table> | APPROVAL | BY | DATE | CHECK | | | ENG. | | | SCALE | | | <table border="1"> <tr> <th>APPROVAL</th> <th>BY</th> <th>DATE</th> </tr> <tr> <td></td> <td></td> <td></td> </tr> </table> | APPROVAL | BY | DATE | | | | <p>MED. HANDHELD/WALL UTIL. SXX-442710X ASSEMBLY</p> |
| APPROVAL | BY | DATE | | | | | | | | | | | | | | | | | | | |
| CHECK | | | | | | | | | | | | | | | | | | | | | |
| ENG. | | | | | | | | | | | | | | | | | | | | | |
| SCALE | | | | | | | | | | | | | | | | | | | | | |
| APPROVAL | BY | DATE | | | | | | | | | | | | | | | | | | | |
| | | | | | | | | | | | | | | | | | | | | | |
| <p>DRAWN BY M BOYER</p> | <p>27-Jun-09</p> | <p>SIZE A</p> | <p>DRAWING NAME 442710X_R4_1</p> | <p>SHEET 1 OF 11</p> | <p>REV.DOC 4.1</p> | | | | | | | | | | | | | | | | |

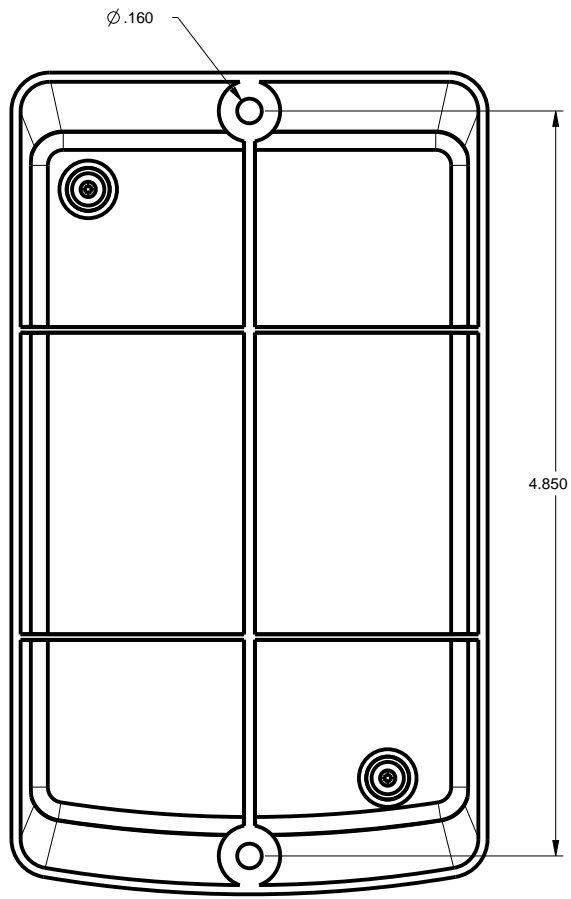
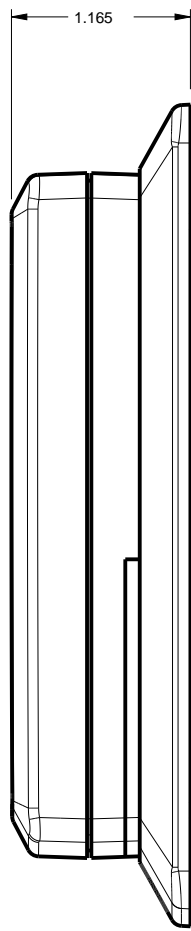
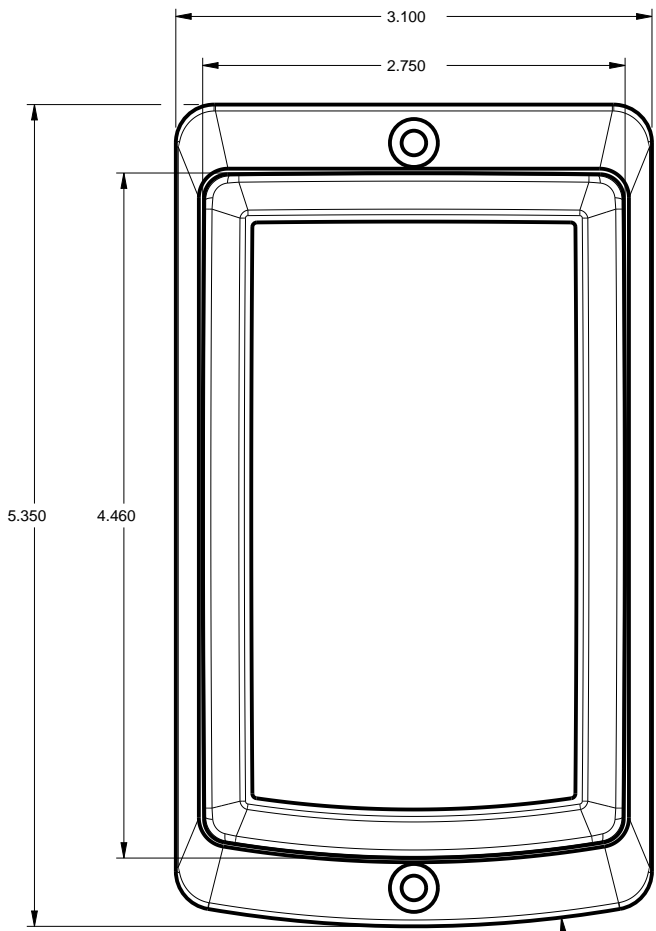

SCALE 0.800

R8.000

| | | | |
|---|---------|---|---|
| TOLERANCES: UNLESS OTHERWISE SPECIFIED DIMENSIONS ARE IN U.S. INCHES: X.XX = .015 X.XXXX = .001 X.XXX = .010 X.X° = 1° | | NEW AGE ENCLOSURES 4330 Santa Fe Road San Luis Obispo, CA. 93401 ph. (805) 595-1310 fax (805) 595-1024 www.newageenclosures.com | |
| Customer's Part No: 442710 | | | |
| APPROVAL | BY | DATE | MED. HANDHELD/WALL UTIL. SXX-442710X ASSEMBLY |
| CHECK | | | |
| ENG. | | | |
| SCALE | | | |
| DRAWN BY | M BOYER | 27-Jun-09 | SIZE A DRAWING NAME 442710X_R4_1 SHEET 2 OF 11 REV.DOC 4.1 |

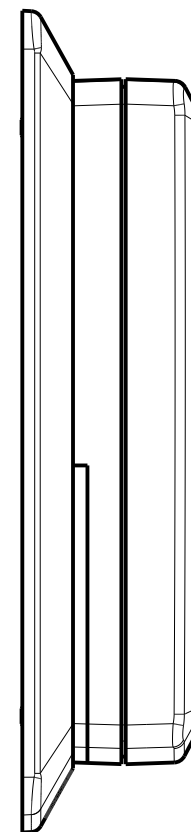
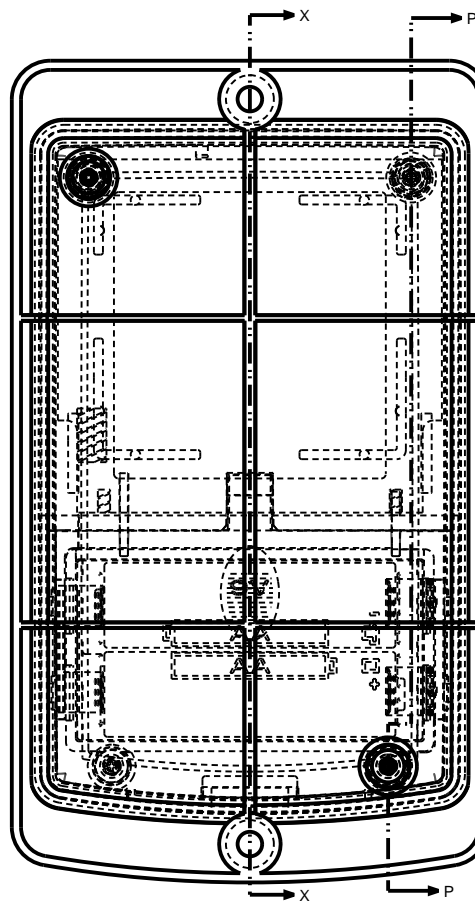
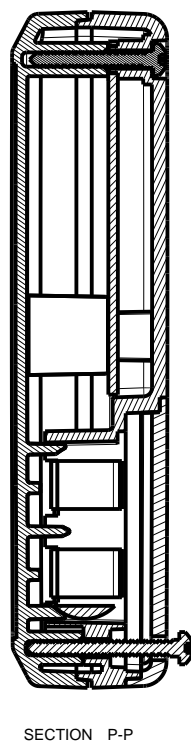
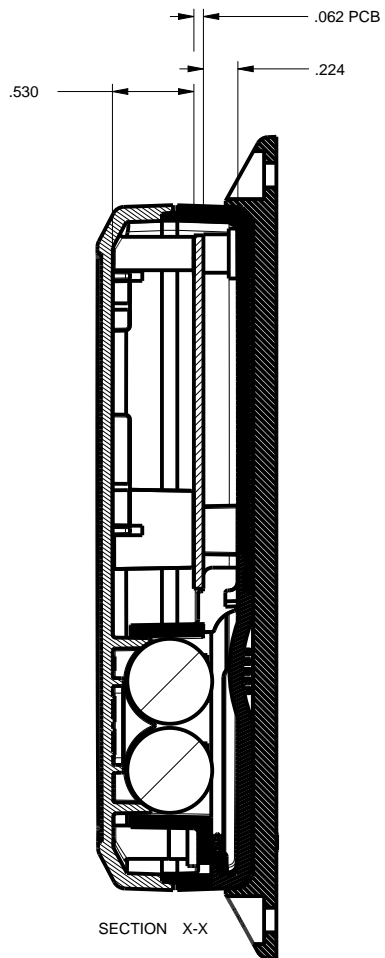

SCALE 0.800

| | | | |
|---|-----------|---|---|
| TOLERANCES: UNLESS OTHERWISE SPECIFIED DIMENSIONS ARE IN U.S. INCHES: X.XX = .015 X.XXXX = .001 X.XXX = .010 X.X° = 1° | | NEW AGE ENCLOSURES 4330 Santa Fe Road San Luis Obispo, CA. 93401 ph. (805) 595-1310 fax (805) 595-1024 www.newageenclosures.com | |
| NEW AGE ENCLOSURES Customer's Part No: 442710 | | | |
| APPROVAL | BY | DATE | MED. HANDHELD/WALL UTIL. SXX-442710X ASSEMBLY |
| CHECK | | | |
| ENG. | | | |
| SCALE | | | |
| DRAWN BY | 27-Jun-09 | | SIZE A DRAWING NAME 442710X_R4_1 SHEET 3 OF 11 REV.DOC 4.1 |

442710 COVER

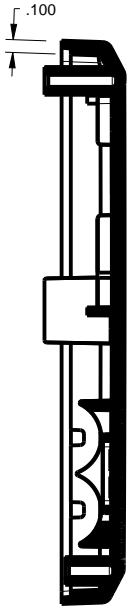

SECTION C-C

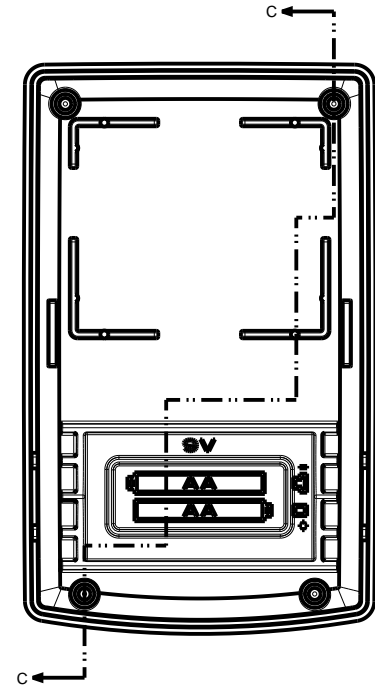
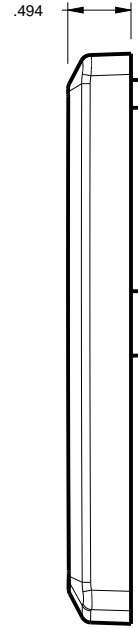
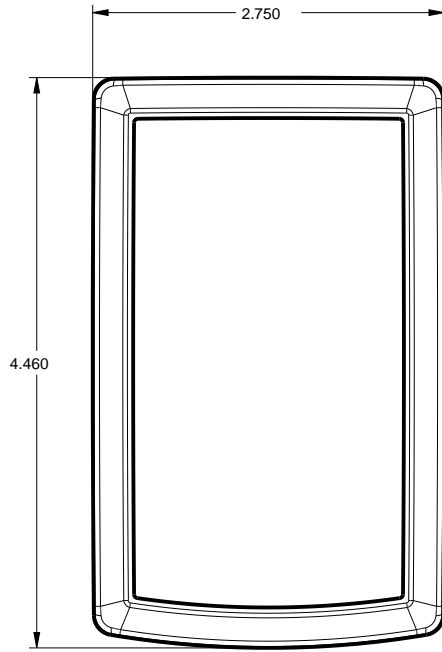
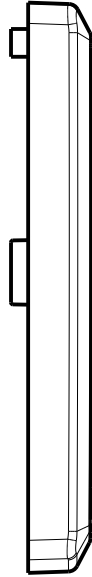

SCALE 0.666



SPECIFIC GEOMETRIC DATA CAN BE OBTAINED FROM THE CAD MODEL AND DOWNLOADED VIA OUR WEBSITE. ALTERNATE FORMS OF CAD INFORMATION ARE AVAILABLE UPON REQUEST.

| | | | |
|--|----|---|--------------|
| TOLERANCES: UNLESS OTHERWISE SPECIFIED DIMENSIONS ARE IN U.S. INCHES: X.XX = .015 X.XXXX = .001 X.XXX = .010 XX° = 1° | | NEW AGE ENCLOSURES 4330 Santa Fe Road San Luis Obispo, CA. 93401 ph. (805) 595-1310 fax (805) 595-1024 www.newageenclosures.com | |
| Customer's Part No: 442710 | | MED. HANDHELD/WALL UTIL. SXX-442710X ASSEMBLY | |
| APPROVAL | BY | DATE | SIZE |
| CHECK | | | A |
| ENG. | | | DRAWING NAME |
| SCALE | | | 442710X_R4_1 |
| DRAWN BY | | | SHEET |
| M BOYER | | 27-Jun-09 | 4 OF 11 |
| | | | REV.DOC |
| | | | 4.1 |

442710 COVER w/ LCD

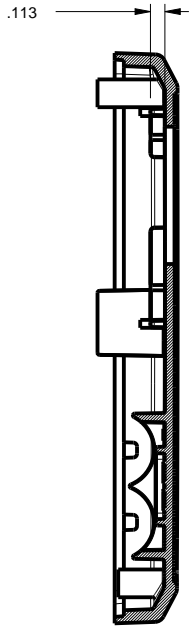

SECTION A-A

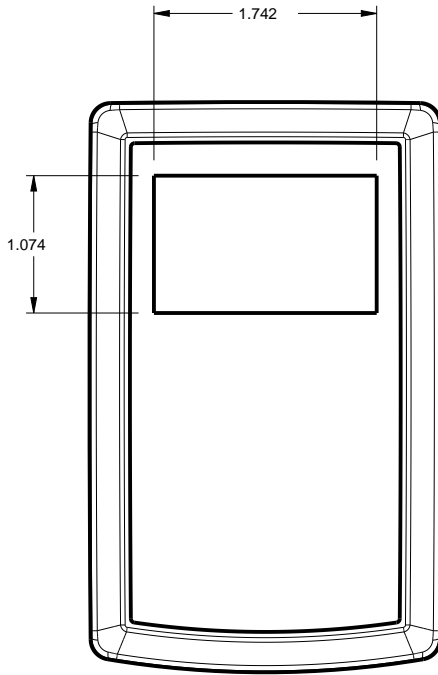
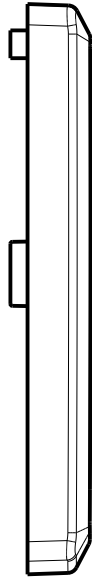

SCALE 0.666

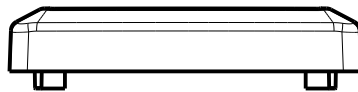
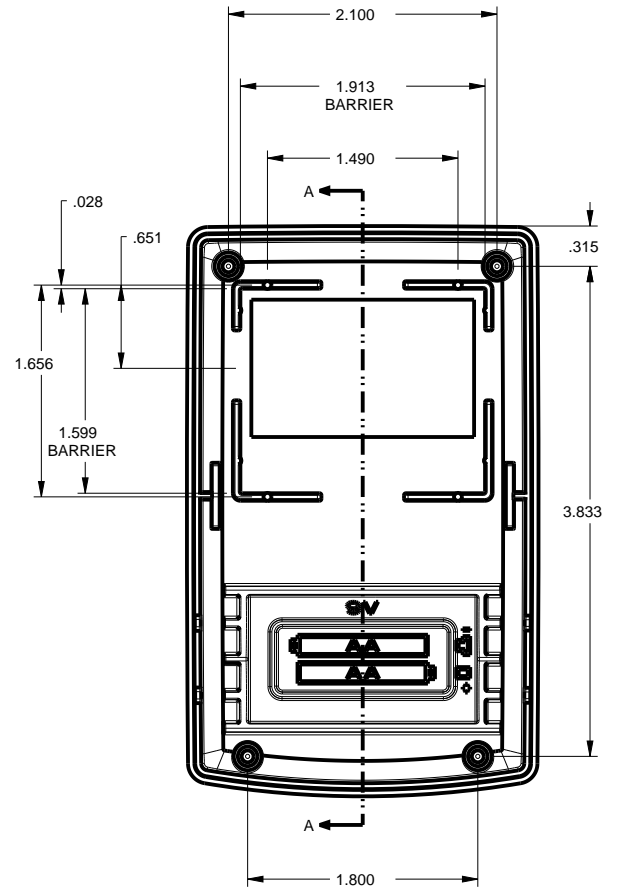
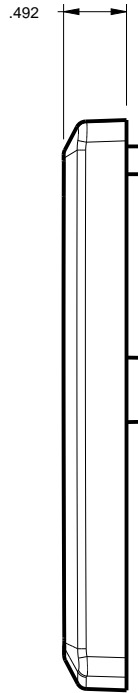

| | | | | | |
|---|-----------|---|--------------|---------|---------|
| TOLERANCES: UNLESS OTHERWISE SPECIFIED DIMENSIONS ARE IN U.S. INCHES: X.XX = .015 X.XXXX = .001 X.XXX = .010 X.X° = 1° | | NEW AGE ENCLOSURES 4330 Santa Fe Road San Luis Obispo, CA. 93401 ph. (805) 595-1310 fax (805) 595-1024 www.newageenclosures.com | | | |
| NEW AGE ENCLOSURES | | | | | |
| Customer's Part No: 442710 | | MED. HANDHELD/WALL UTIL. SXX-442710X ASSEMBLY | | | |
| APPROVAL | BY DATE | | | | |
| CHECK | | | | | |
| ENG. | | | | | |
| SCALE | | SIZE | DRAWING NAME | SHEET | REV.DOC |
| M BOYER | 27-Jun-09 | A | 442710X_R4_1 | 5 OF 11 | 4.1 |

442710 BASE

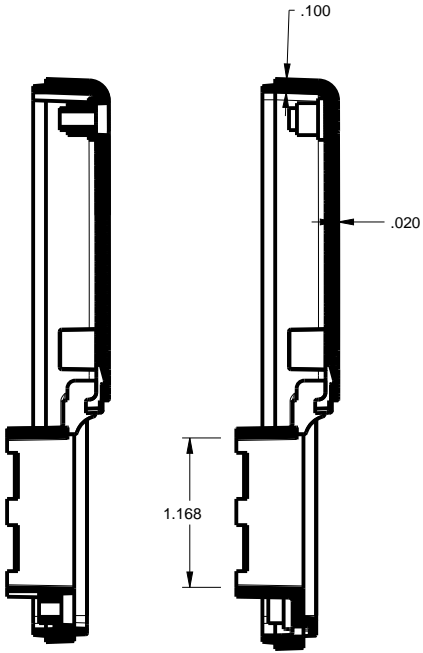
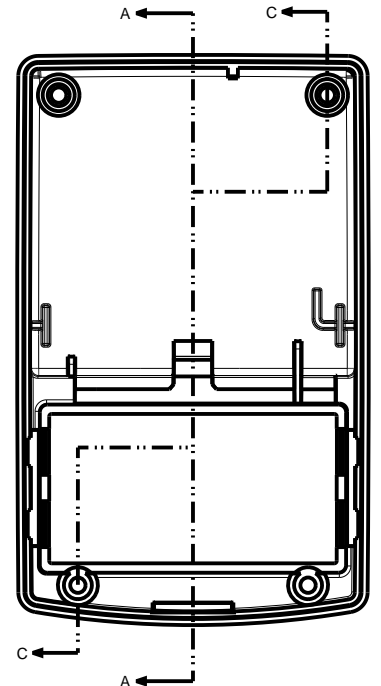
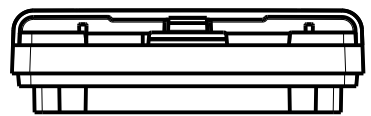
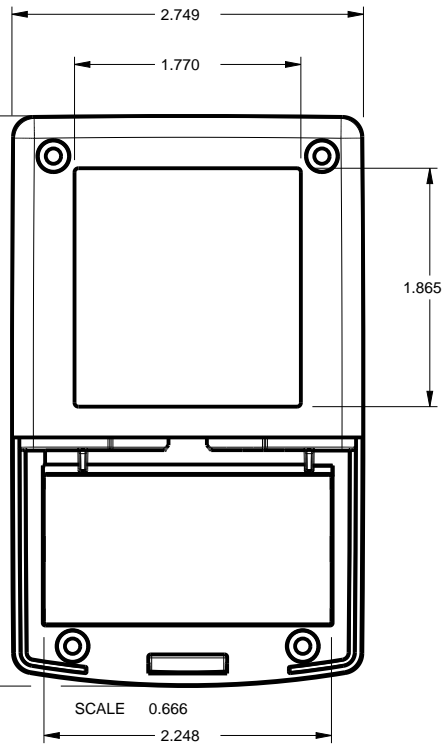
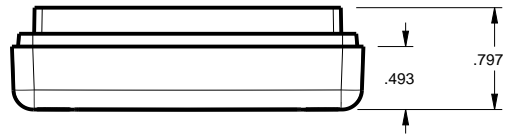

SECTION C-C

SECTION A-A

SCALE 0.666

| | | | |
|---|---------|---|---|
| TOLERANCES: UNLESS OTHERWISE SPECIFIED DIMENSIONS ARE IN U.S. INCHES: X.XX = .015 X.XXXX = .001 X.XXX = .010 X.X° = 1° | | NEW AGE ENCLOSURES 4330 Santa Fe Road San Luis Obispo, CA. 93401 ph. (805) 595-1310 fax (805) 595-1024 www.newageenclosures.com | |
| Customer's Part No: 442710 | | | |
| APPROVAL | BY | DATE | MED. HANDHELD/WALL UTIL. SXX-442710X ASSEMBLY |
| CHECK | | | |
| ENG. | | | |
| SCALE | | | |
| DRAWN BY | M BOYER | 27-Jun-09 | SIZE A DRAWING NAME 442710X_R4_1 SHEET 6 OF 11 REV.DOC 4.1 |

442710 HATCH

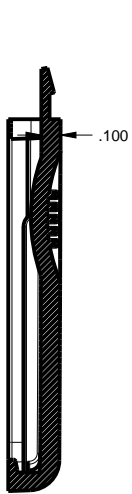
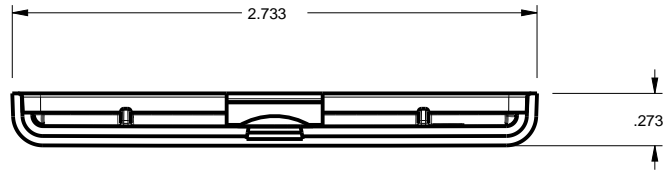

SECTION A-A

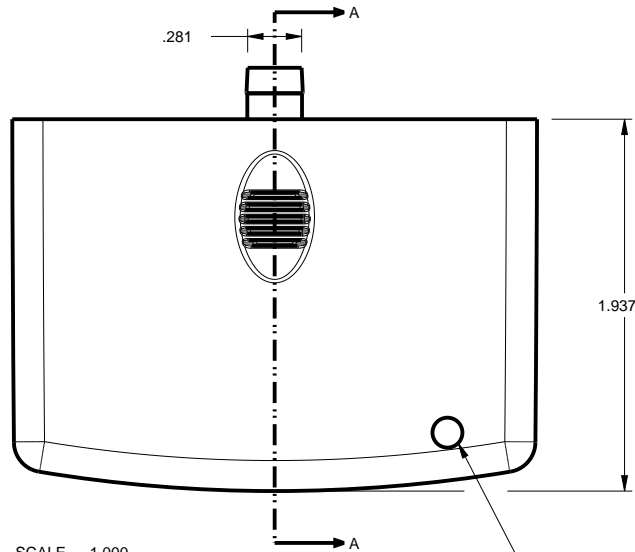

SCALE 1.000

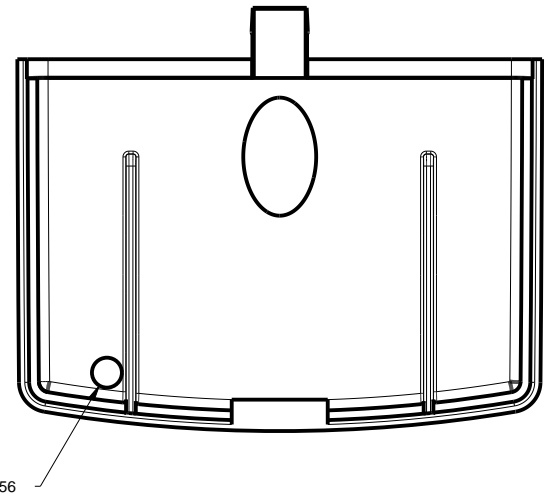
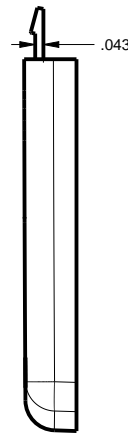

2nd OPERATION:
CLEARANCE FOR ATTACHMENT
OF WALL PLATE (S442710WE)

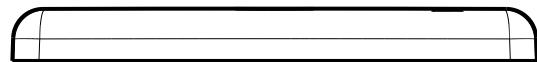

| | | | |
|---|---------|--|--|
| TOLERANCES: UNLESS OTHERWISE SPECIFIED DIMENSIONS ARE IN U.S. INCHES: X.XX = .015 X.XXXX = .001 X.XXX = .010 X.X° = 1° | | NEW AGE ENCLOSURES | |
| Customer's Part No: 442710 | | 4330 Santa Fe Road San Luis Obispo, CA. 93401 ph. (805) 595-1310 fax (805) 595-1024 www.newageenclosures.com | |
| APPROVAL | BY | DATE | MED. HANDHELD/WALL UTIL. SXX-442710X ASSEMBLY |
| CHECK | | | |
| ENG. | | | |
| SCALE | | | |
| DRAWN BY | M BOYER | 27-Jun-09 | SIZE A |
| | | | DRAWING NAME 442710X_R4_1 |
| | | | SHEET 7 OF 11 |
| | | | REV.DOC 4.1 |

442710 WALL PLATE

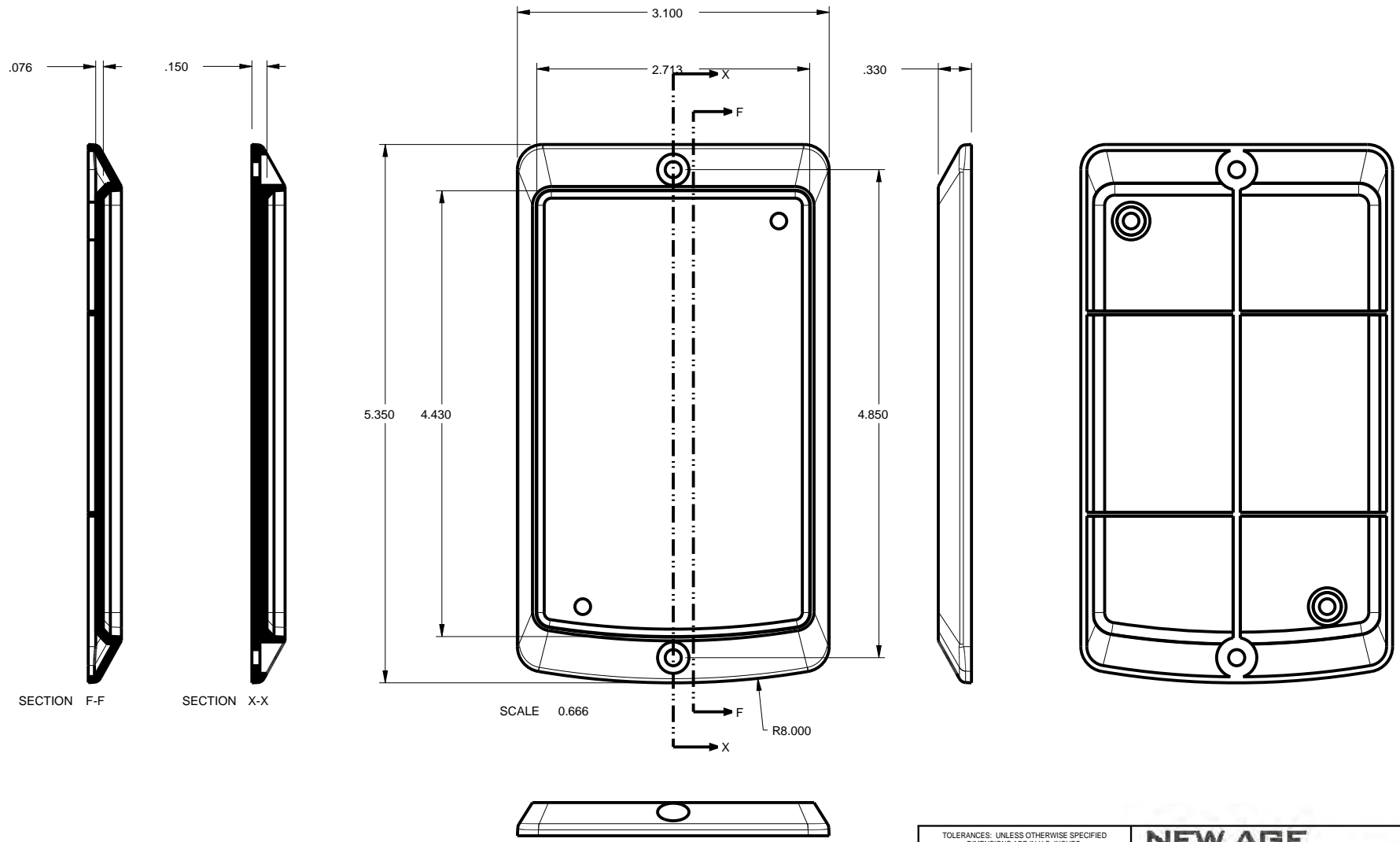

| | | | |
|---|-----------|---|---|
| TOLERANCES: UNLESS OTHERWISE SPECIFIED DIMENSIONS ARE IN U.S. INCHES: X.XX = .015 X.XXXX = .001 X.XXX = .010 X.X° = 1° | | NEW AGE ENCLOSURES 4330 Santa Fe Road San Luis Obispo, CA. 93401 ph. (805) 595-1310 fax (805) 595-1024 www.newageenclosures.com | |
| NEW AGE ENCLOSURES Customer's Part No: 442710 | | | |
| APPROVAL | BY | DATE | MED. HANDHELD/WALL UTIL. SXX-442710X ASSEMBLY |
| CHECK | | | |
| ENG. | | | |
| SCALE | | | |
| DRAWN BY | 27-Jun-09 | | SIZE A DRAWING NAME 442710X_R4_1 SHEET 8 OF 11 REV.DOC 4.1 |

S442710 PCB - CUSTOMER SUPPLIED

PCB SIZES ARE RECOMMENDATIONS ONLY. FINAL SIZES AND VERIFICATION OF IT'S FIT ARE THE SOLE RESPONSIBILITY OF THE OEM.

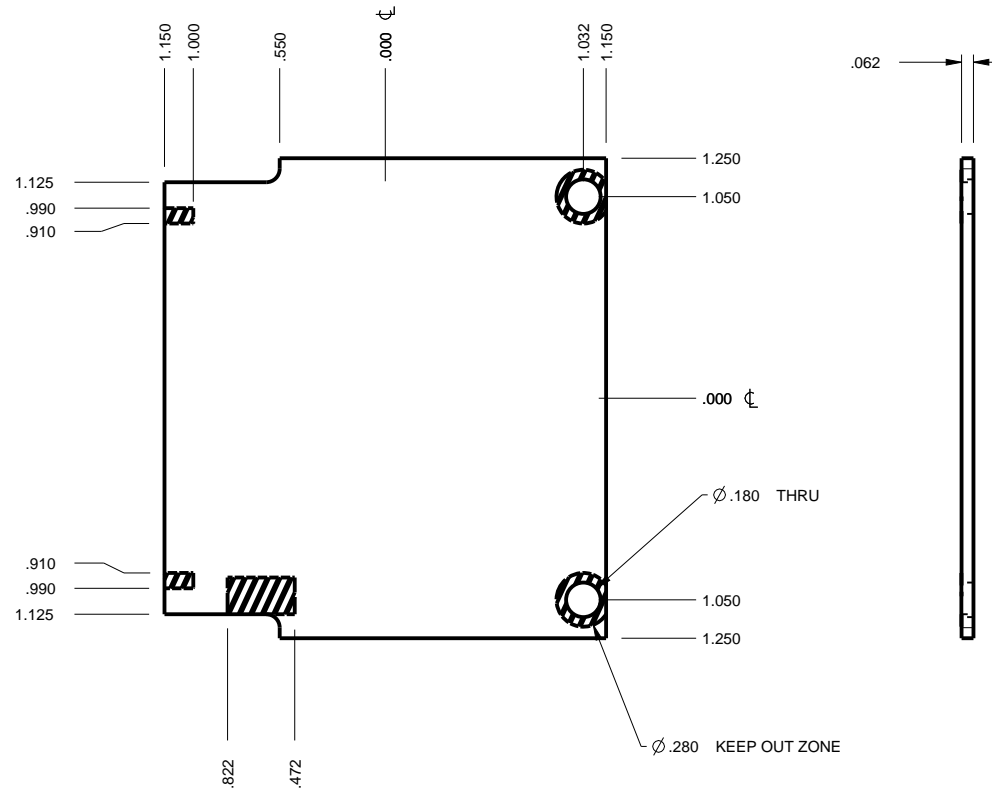

SCALE 1.000

| | | | |
|---|-----------|---|---|
| TOLERANCES: UNLESS OTHERWISE SPECIFIED DIMENSIONS ARE IN U.S. INCHES: X.XX = .015 X.XXXX = .001 X.XXX = .010 X.X° = 1° | | NEW AGE ENCLOSURES 4330 Santa Fe Road San Luis Obispo, CA. 93401 ph. (805) 595-1310 fax (805) 595-1024 www.newageenclosures.com | |
| NEW AGE ENCLOSURES Customer's Part No: 442710 | | | |
| APPROVAL | BY | DATE | MED. HANDHELD/WALL UTIL. SXX-442710X ASSEMBLY |
| CHECK | | | |
| ENG. | | | |
| SCALE | | | |
| DRAWN BY | 27-Jun-09 | | SIZE A DRAWING NAME 442710X_R4_1 SHEET 9 OF 11 REV.DOC 4.1 |

SUGGESTED LABEL SIZE

(w/ .01" minimum gap per side)
CUSTOMER SUPPLIED

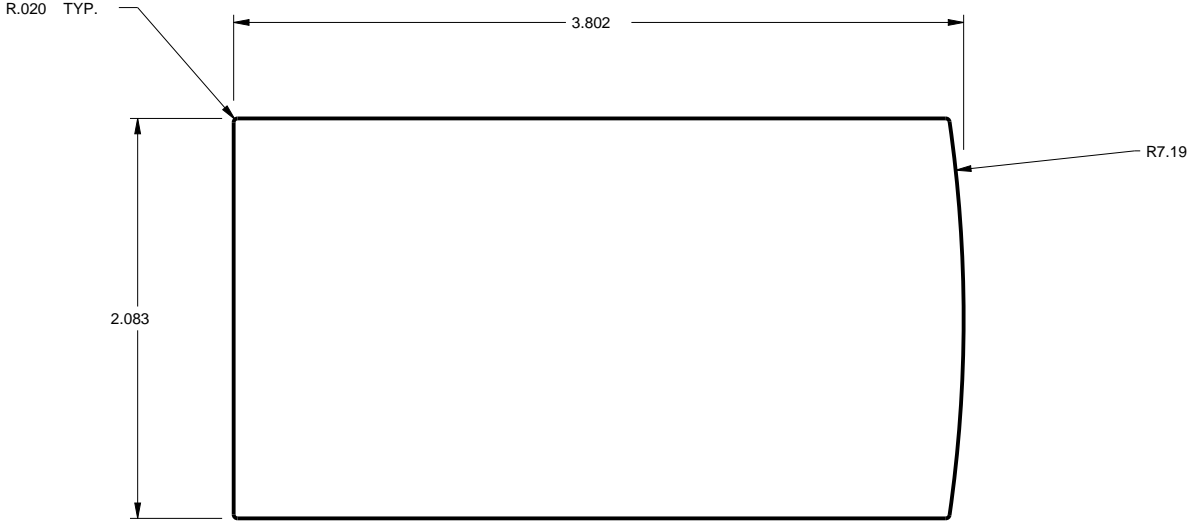

SCALE 1.000

| | | | | | | |
|---|----|---|--|--------------|----------|---------|
| <small>TOLERANCES: UNLESS OTHERWISE SPECIFIED DIMENSIONS ARE IN U.S. INCHES: X.XX = .015 X.XXXX = .001 X.XXX = .010 X.X° = 1°</small> | | NEW AGE ENCLOSURES 4330 Santa Fe Road San Luis Obispo, CA. 93401 ph. (805) 595-1310 fax (805) 595-1024 www.newageenclosures.com | | | | |
| Customer's Part No: 442710 | | | | | | |
| APPROVAL | BY | DATE | MED. HANDHELD/WALL UTIL. SXX-442710X ASSEMBLY | | | |
| CHECK | | | | | | |
| ENG. | | | | | | |
| SCALE | | | | | | |
| DRAWN BY | | | SIZE | DRAWING NAME | SHEET | REV.DOC |
| M BOYER | | 27-Jun-09 | A | 442710X_R4_1 | 10 OF 11 | 4.1 |

2nd OPERATION DETAILS

New Age Enclosures DELIVERS YOUR ENCLOSURE MARKET-READY WITH IN-HOUSE
CNC MACHINING, PAD PRINTING, ASSEMBLY, AND FULFILLMENT.
ALL SURFACES AND AREAS ARE AVAILABLE FOR CNC ALTERATION BY New Age Enclosures
CALL (805) 595-1310 FOR PRICING AND SCHEDULE.
THE INSIDE RADIUS OF ANY MACHINED FEATURES SHOULD BE NO SMALLER THAN .031"

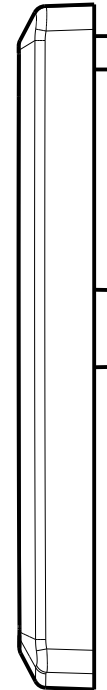
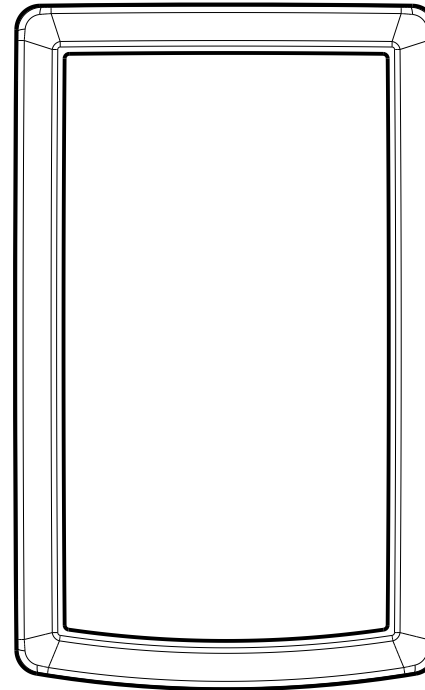
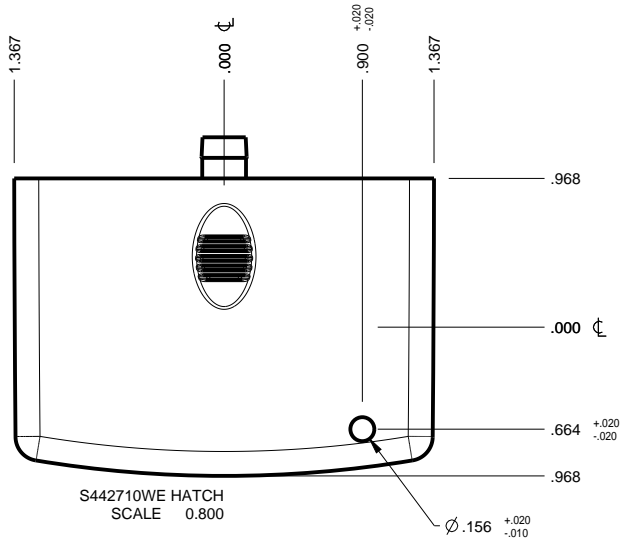

S442710 COVER
SCALE 0.800

| SXX-442710WE-XXX HATCH - ABS, BLACK | | | | | |
|-------------------------------------|---------------------|---------------|---------|---------------------------|---------|
| STEP NO | DESCRIPTION | CUTTER | FIXTURE | ORIENTATION | PROGRAM |
| 1 | ∅.156 ASSEMBLY HOLE | T2 = .062" EM | 113 | USE ENCLOSURE ASSEMBLY | o4977 |
| SXX-442710-XXX COVER - ABS, BLACK | | | | | |
| STEP NO | DESCRIPTION | CUTTER | FIXTURE | ORIENTATION | PROGRAM |
| 2 | - | T2 = .062" EM | 113 | CENTER BLOCK - RAD. RIGHT | - |
| SXX-442710-XXX BASE - ABS, BLACK | | | | | |
| STEP NO | DESCRIPTION | CUTTER | FIXTURE | ORIENTATION | PROGRAM |
| 3 | - | T2 = .062" EM | 113 | CENTER BLOCK - RAD. RIGHT | - |

TOLERANCES: UNLESS OTHERWISE SPECIFIED
DIMENSIONS ARE IN U.S. INCHES:
X.XX = .015 X.XXXX = .001
X.XXX = .010 XX° = 1°

NEW AGE ENCLOSURES

Customer's Part No: 442710

APPROVAL BY DATE

CHECK

ENG.

SCALE

DRAWN BY M BOYER 27-Jun-09

NEW AGE ENCLOSURES

4330 Santa Fe Road San Luis Obispo, CA. 93401
ph. (805) 595-1310 fax (805) 595-1024
www.newageenclosures.com

**MED. HANDHELD/WALL UTIL.
SXX-442710X ASSEMBLY**

| | | | |
|------|--------------|----------|---------|
| SIZE | DRAWING NAME | SHEET | REV.DOC |
| A | 442710X_R4_1 | 11 OF 11 | 4.1 |

Mouser Electronics

Authorized Distributor

Click to View Pricing, Inventory, Delivery & Lifecycle Information:

New Age Enclosures:

[S1A-442710-WE](#) [S1A-442710](#) [S3A-442710-WP](#) [S3A-442710-WE](#) [S3A-442710](#) [S1A-442710-WP](#) [S1A-442710LCD](#)



Компания «ЭлектроПласт» предлагает заключение долгосрочных отношений при поставках импортных электронных компонентов на взаимовыгодных условиях!

Наши преимущества:

- Оперативные поставки широкого спектра электронных компонентов отечественного и импортного производства напрямую от производителей и с крупнейших мировых складов;
- Поставка более 17-ти миллионов наименований электронных компонентов;
- Поставка сложных, дефицитных, либо снятых с производства позиций;
- Оперативные сроки поставки под заказ (от 5 рабочих дней);
- Экспресс доставка в любую точку России;
- Техническая поддержка проекта, помощь в подборе аналогов, поставка прототипов;
- Система менеджмента качества сертифицирована по Международному стандарту ISO 9001;
- Лицензия ФСБ на осуществление работ с использованием сведений, составляющих государственную тайну;
- Поставка специализированных компонентов (Xilinx, Altera, Analog Devices, Intersil, Interpoint, Microsemi, Aeroflex, Peregrine, Syfer, Eurofarad, Texas Instrument, Miteq, Cobham, E2V, MA-COM, Hittite, Mini-Circuits, General Dynamics и др.);

Помимо этого, одним из направлений компании «ЭлектроПласт» является направление «Источники питания». Мы предлагаем Вам помощь Конструкторского отдела:

- Подбор оптимального решения, техническое обоснование при выборе компонента;
- Подбор аналогов;
- Консультации по применению компонента;
- Поставка образцов и прототипов;
- Техническая поддержка проекта;
- Защита от снятия компонента с производства.



Как с нами связаться

Телефон: 8 (812) 309 58 32 (многоканальный)

Факс: 8 (812) 320-02-42

Электронная почта: org@eplast1.ru

Адрес: 198099, г. Санкт-Петербург, ул. Калинина, дом 2, корпус 4, литера А.