

ZL9024M

Digital DC/DC PMBus 33A Module

FN8837
Rev. 2.00
Jan 29, 2018

The [ZL9024M](#) is a 33A step-down DC/DC power supply module with integrated digital PWM controller, synchronous power switches, an inductor, and passives. Only bulk input and output capacitors are needed to finish the design. The 33A of continuous output current can be delivered without a need of airflow or a heatsink. The thermally enhanced HDA module is capable of dissipating heat directly into the PCB.

The ZL9024M uses ChargeMode™ control architecture, which responds to a transient load within a single switching cycle. The ZL9024M comes with a preprogrammed configuration for operating in a pin-strap mode; output voltage, switching frequency, and device SMBus address can be programmed with external resistors. More configurations, such as soft-start and fault limits, can be easily programmed or changed using PMBus compliant serial bus interface. PMBus can be used to monitor voltages, current, temperatures, and fault status. The ZL9024M is supported by PowerNavigator™ software, a Graphical User Interface (GUI) that can be used to configure modules to a desired solution.

The ZL9024M is available in a 40 Ld compact 17mmx19mm HDA module with a very low profile height of 3.55mm, suitable for automated assembly by standard surface mount equipment. The ZL9024M is RoHS compliant by exemption.

Related Literature

For a full list of related documents, visit our website

- [ZL9024M](#) product page

Features

- Complete digital switch mode power supply
 - V_{IN} range: 2.75V to 4V
 - Programmable V_{OUT} range: 0.6V to 1.5V
- PMBus compliant I²C communication interface
 - Programmable V_{OUT} , margining, UV/OV, I_{OUT} limit, soft-start/stop, sequencing, and external synchronization
 - Monitor: V_{IN} , V_{OUT} , I_{OUT} , temperature, duty cycle, switching frequency, and faults
- ChargeMode control architecture
- ±1.2% V_{OUT} accuracy over line, load, and temperature
- Power-good indicator
- Over-temperature protection
- Internal non-volatile memory and fault logging
- [PowerNavigator](#) supported
- Patented thermally enhanced HDA package

Applications

- Server, telecom, storage, and datacom
- Industrial/ATE and networking equipment
- General purpose power for ASIC, FPGA, DSP, and memory

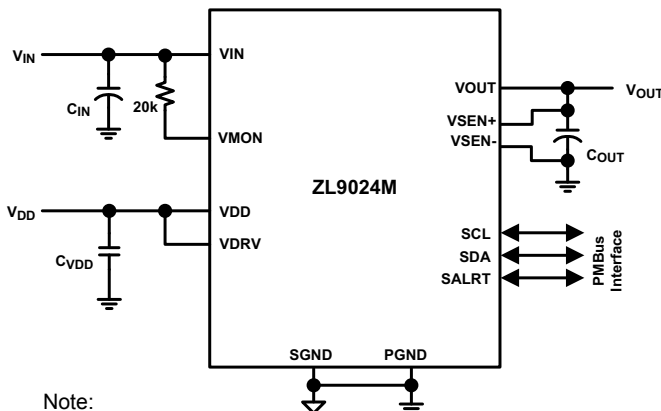

Note:
1. Only input and output capacitors are required to finish the design.

Figure 1. Complete Digital Switch Mode Power Supply

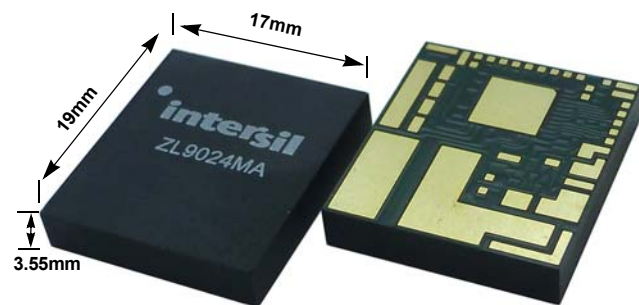

Figure 2. Small Package for High Power Density

Contents

1. Overview	4
1.1 Block Diagram	4
1.2 Ordering Information	5
1.3 Pin Configuration	6
1.4 Pin Descriptions	6
1.5 Typical Application Circuit	8
2. Specifications	10
2.1 Absolute Maximum Ratings	10
2.2 Thermal Information	10
2.3 Recommended Operating Conditions	11
2.4 Electrical Specifications	11
3. Typical Performance Curves	14
4. Functional Description	16
4.1 SMBus Communications	16
4.2 Output Voltage Selection	16
4.3 Soft-Start Delay and Ramp Times	17
4.4 Power-Good	17
4.5 Switching Frequency and PLL	17
4.6 Loop Compensation	18
4.7 Undervoltage Lockout (UVLO)	18
4.8 SMBus Module Address Selection	18
4.9 Output Overvoltage Protection	19
4.10 Output Prebias Protection	19
4.11 Output Overcurrent Protection	20
4.12 Thermal Overload Protection	20
4.13 Digital-DC Bus	20
4.14 Phase Spreading	20
4.15 Output Sequencing	21
4.16 Fault Spreading	21
4.17 Temperature Monitoring Using the XTEMP Pin	21
4.18 Monitoring Using SMBus	22
4.19 Snapshot Parameter Capture	22
4.20 Non-Volatile Memory	22
5. PCB Layout Guidelines	23
6. Thermal Considerations	25
6.1 Package Description	25
6.2 PCB Layout Pattern Design	25
6.3 Thermal Vias	25
6.4 Stencil Pattern Design	25
6.5 Reflow Parameters	26

7.	PMBus Command Summary	27
8.	PMBus Data Formats	31
9.	PMBus Use Guidelines	32
9.1	Summary	32
10.	PMBus Commands Description	33
11.	Firmware Revision History	64
12.	Package Outline Drawing	65
13.	Revision History	72

1. Overview

1.1 Block Diagram

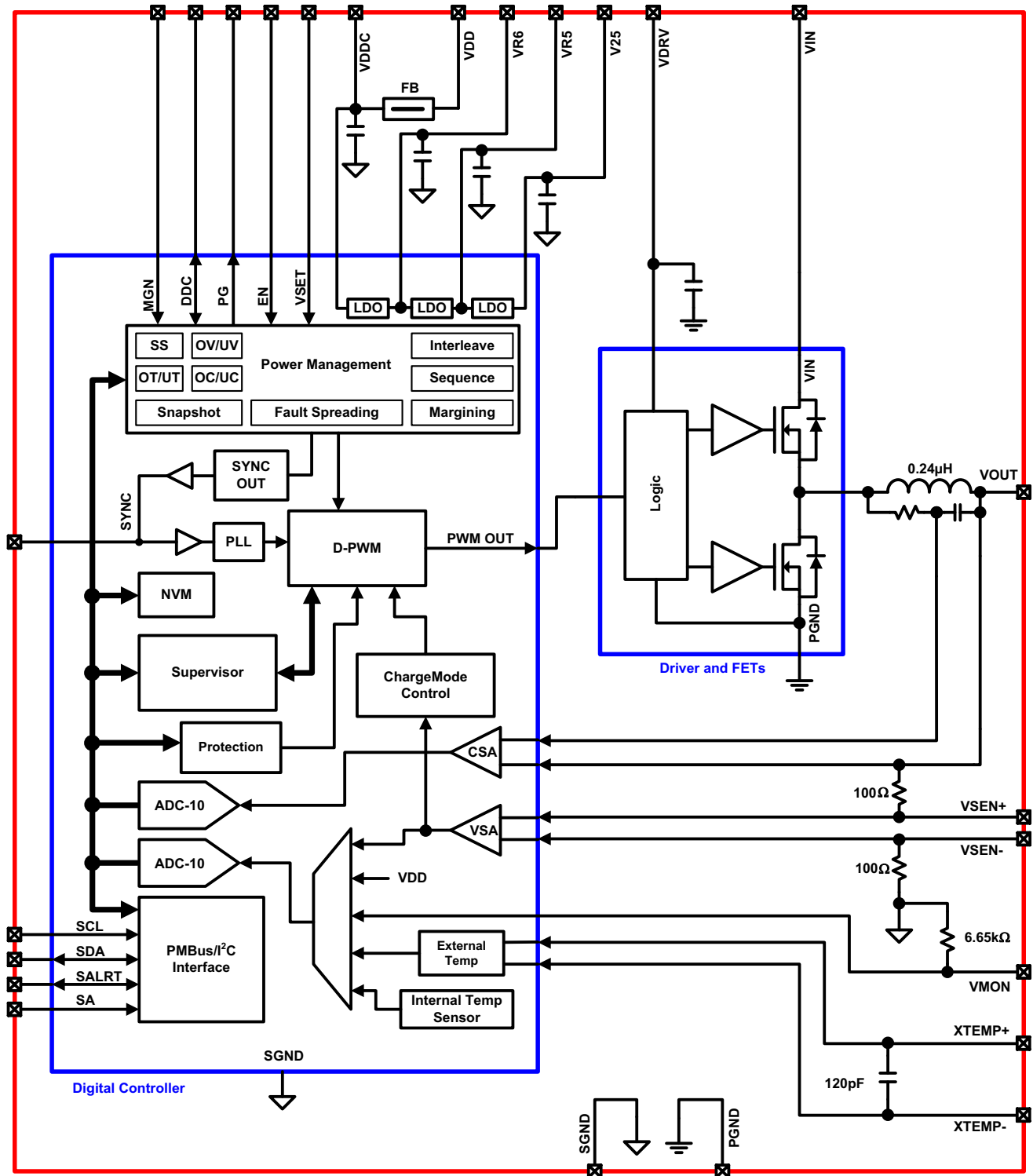

Figure 3. ZL9024M Internal Block Diagram

1.2 Ordering Information

Part Number (Notes 2, 3, 4, 5)	Part Marking	Firmware Revision (Note 6)	Temp Range (°C)	Package (RoHS Compliant)	Pkg. Dwg. #
ZL9024MAIRZ	ZL9024MA	G0100	-40 to +85	40 Ld 17x19 HDA	Y40.17x19
ZL9024MEVAL1Z	Evaluation Board				

Notes:

- Add "-T" suffix for 500 unit tape and reel option. Refer to [TB347](#) for details about reel specifications.
- Add "-T1" suffix for 100 unit tape and reel option. Refer to [TB347](#) for details about reel specifications.
- These Pb-free plastic packaged products are RoHS compliant by EU exemption 7C-I and 7A. They employ special Pb-free material sets; molding compounds/die attach materials and NiPdAu plate-e4 termination finish, which is compatible with both SnPb and Pb-free soldering operations. Pb-free products are MSL classified at Pb-free peak reflow temperatures that meet or exceed the Pb-free requirements of IPC/JEDEC J STD-020.
- For Moisture Sensitivity Level (MSL), see the [ZL9024M](#) product information page. For more information about MSL, refer to [TB363](#).
- See "[Firmware Revision History](#)" on page 64; only the latest firmware revision is recommended for new designs.

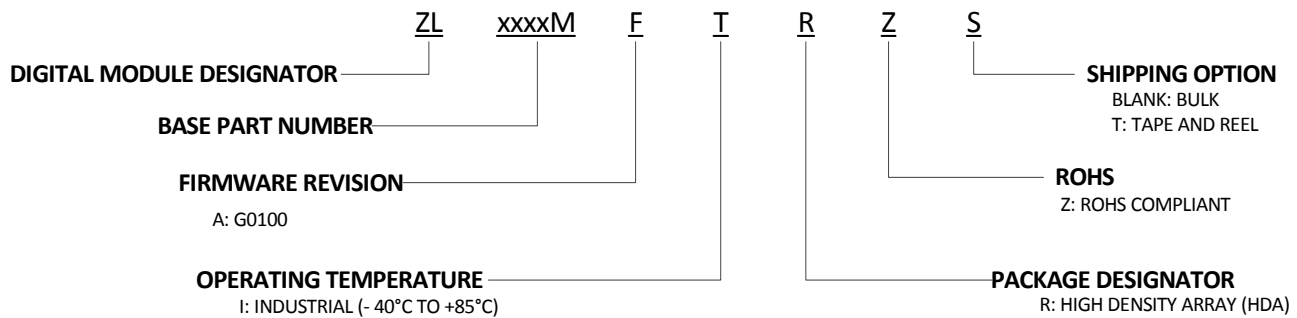
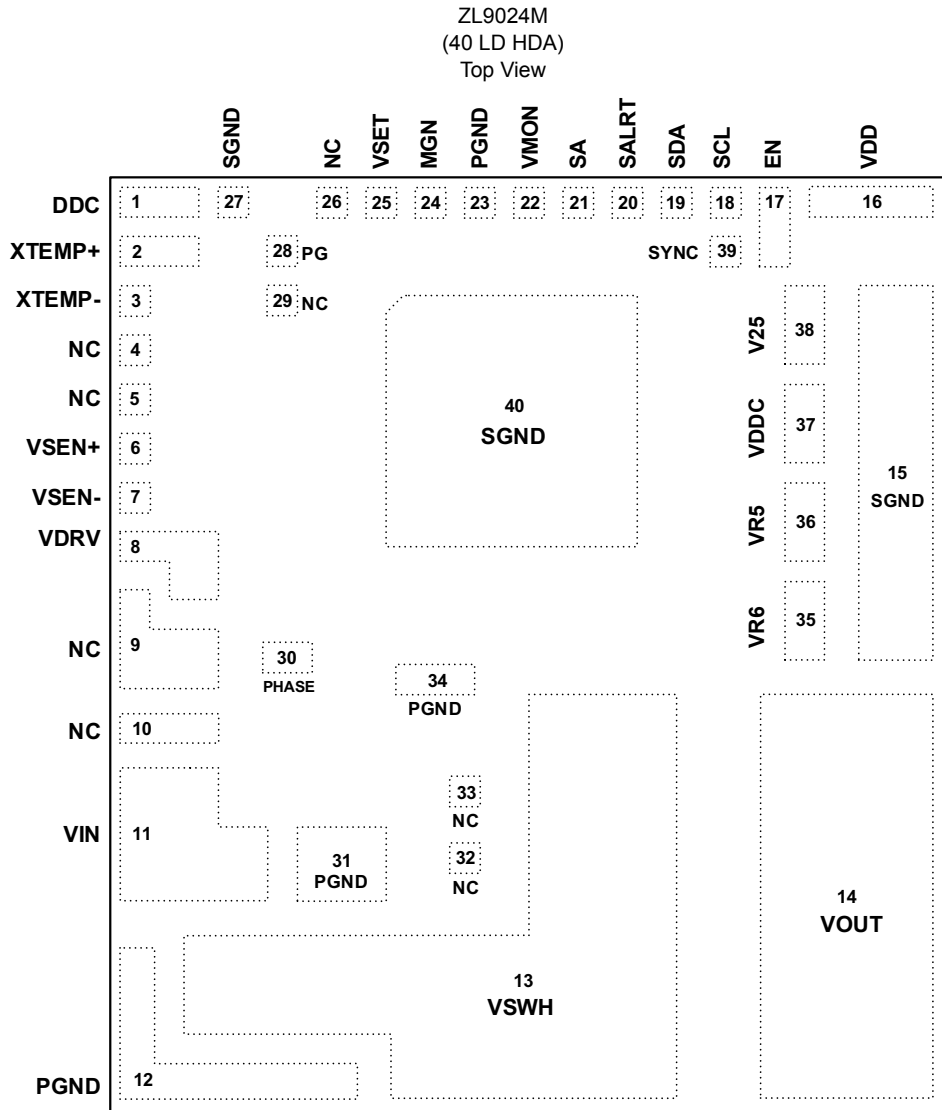

Table 1. Key Differences Between Family of Parts

Part	Description	V _{IN} Range (V)	V _{OUT} Range (V)	I _{OUT} (A)
ZL9024M	Digital DC/DC PMBus Single Channel 33A Module	2.75 - 4	0.6 - 1.5	33
ISL8274M	Digital DC/DC PMBus Dual Channel 30A/30A Module	4.5 - 14	0.6 - 5.0	30/30
ISL8277M	Digital DC/DC PMBus 25A Module	4.5 - 14	0.6 - 5.0	25
ISL8278M	Digital DC/DC PMBus 33A Module	4.5 - 14	0.6 - 5.0	33

1.3 Pin Configuration



1.4 Pin Descriptions

Pin	Label	Type	Description
1	DDC	I/O	A Digital-DC™ bus. This dedicated bus provides the communication channel between devices for features such as sequencing, fault spreading, and current sharing. The DDC pin on all Digital-DC devices should be connected together. A pull-up resistor is required for this application.
2	XTEMP+	I	Differential external temperature sensor positive input pin.
3	XTEMP-	I	Differential external temperature sensor negative input pin.
6	VSEN+	I	Differential output voltage sense feedback. Connect to positive output regulation point.
7	VSEN-	I	Differential output voltage sense feedback. Connect to negative output regulation point.
8	VDRV	PWR	Input supply to internal gate driver. Connect the VDRV pad to VDD. Place a 10µF ceramic capacitor at this pin.
12, 23, 31, 34	PGND	PWR	Power ground. Refer to the “PCB Layout Guidelines” on page 23 for the PGND pad connections and decoupling capacitors placement.

Pin	Label	Type	Description
11	VIN	PWR	Main input supply. Refer to the "PCB Layout Guidelines" on page 23 for the decoupling capacitors placement from VIN to PGND.
13	VSWH	PWR	Switch node. Refer to the "PCB Layout Guidelines" on page 23 for connecting VSWH pads to electrically isolated PCB copper island to dissipate internal heat.
14	VOUT	PWR	Power supply output. Range: 0.6V to 1.5V.
15, 27, 40	SGND	PWR	Controller signal ground. Refer to the "PCB Layout Guidelines" on page 23 for the SGND pad connections.
16	VDD	PWR	Input supply to digital controller. Refer to the "PCB Layout Guidelines" on page 23 for the decoupling capacitors placement from VDD to SGND.
17	EN	I	External enable input. Logic high enables the module.
18	SCL	I	Serial clock input. A pull-up resistor is required for this application.
19	SDA	I/O	Serial data. A pull-up resistor is required for this application.
20	SALRT	O	Serial alert. A pull-up resistor is required for this application.
21	SA	I	Serial bus address select pin. Refer to Table 6 for list of resistor values to set various serial bus address.
22	VMON	I	Input voltage monitoring. Use this pin to monitor input voltage. Tie to VIN through a 20kΩ resistor.
24	MGN	I	External V _{OUT} margin control pin. An active high (>2V) signal at this pin sets V _{OUT} margin high, active low (<0.8V) sets V _{OUT} margin low, and high impedance (float) will bring V _{OUT} back to nominal voltage. Factory default range for margining is nominal V _{OUT} ±5%. When using PMBus to control margin command, leave this pin as no connect.
25	VSET	I	Output voltage selection pin. Refer to Table 4 for list of resistor values to set various output voltages.
28	PG	O	Power-good output. The power-good output can be open drain that requires a pull-up resistor or push-pull output that can drive a logic input.
30	PHASE	PWR	Switch node pad for DCR sensing. Electrically shorted inside to VSWH, but for higher current sensing accuracy connect the PHASE pad to the VSWH pad externally. Refer to the "PCB Layout Guidelines" on page 23 .
35	VR6	PWR	Internal reference supply voltage. Tie to the VDDC pin.
36	VR5	PWR	Internal reference supply voltage. Tie to the VDDC pin.
37	VDDC	PWR	VDD clean. Noise at the VDD pin is filtered with ferrite bead and capacitor. Connect the VDDC pin to the VR6 and VR5 pins.
38	V25	PWR	2.5V internal reference supply voltage.
39	SYNC	I/O	The SYNC pin can be input to external clock for frequency synchronization or output to supply clock signals to other modules for synchronization. Refer to Table 5 for a list of resistor values to program various switching frequencies.
4, 5, 9, 10, 26, 29, 32, 33	NC		These are test pins and are not electrically isolated. Leave these pins as no connect.

1.5 Typical Application Circuit

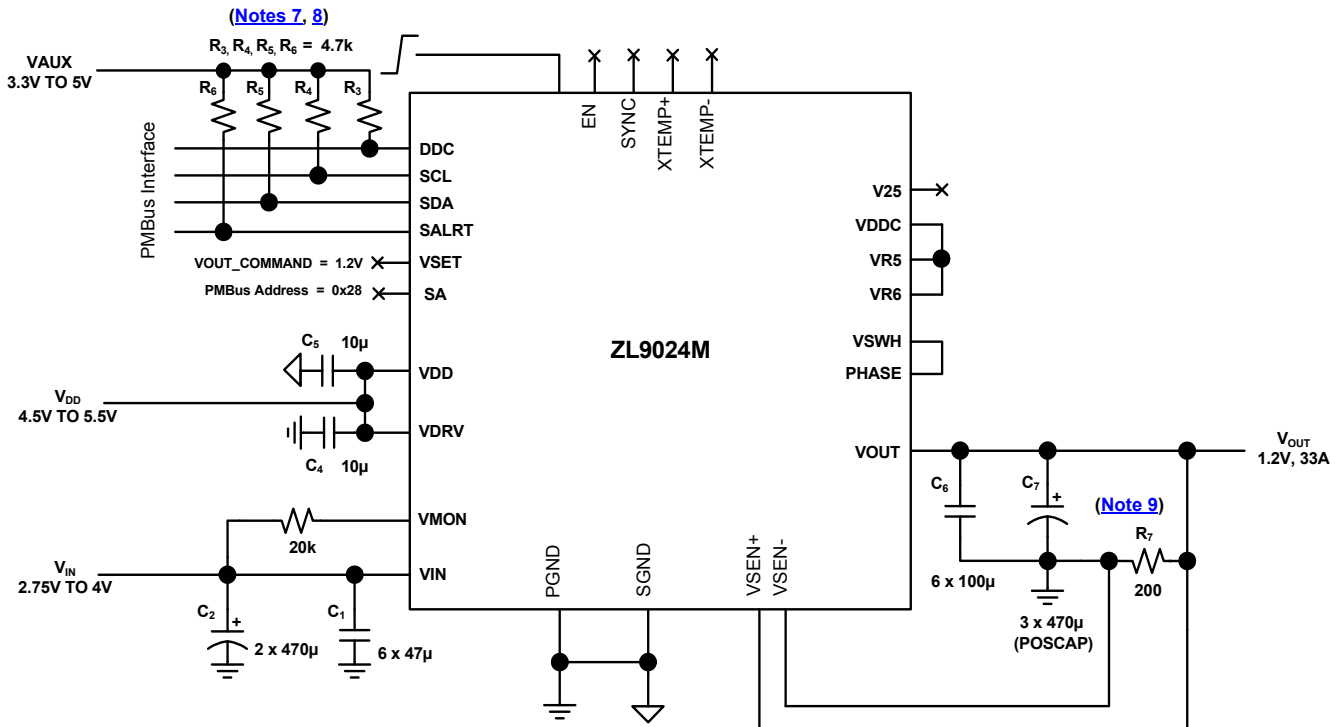

Notes:

- 7. R₄ and R₅ are not required if the PMBus host already has I²C pull-up resistors.
- 8. Only one R₃ per DDC bus is required when DDC bus is shared with other modules.
- 9. R₇ is optional but recommended to sink possible ~100µA back-flow current from the VSEN+ pin. Back-flow current is present only when the module is in a disabled state with power still available at the VDD pin.
- 10. Refer to [“PCB Layout Guidelines” on page 23](#) for more information.

Figure 4. Typical Single Phase Application Circuit for 1.2V/33A Output

Table 2. ZL9024M Design Guide Matrix and Output Voltage Response

Vout (V)	COUT_Bulk (µF)	COUT_Ceramic (µF)	ASCR Gain (Note 11)	ASCR Residual (Note 11)	Voltage Deviation (mV)	Recovery Time (µs)	Load Step (A)	Frequency (kHz) (Note 12)
0.6	5 x 470	6 x 100	300	70	53	35	0 to 16.5	320
0.6	5 x 470	6 x 100	750	70	38	20	0 to 16.5	533
1	4 x 470	6 x 100	450	80	50	20	0 to 16.5	533
1.2	4 x 470	6 x 100	500	80	55	25	0 to 16.5	533
1.5	3 x 470	5 x 100	500	80	60	20	0 to 16.5	533

Notes:

- 11. ASCR gain and residual are designed to achieve a phase margin higher than 60° and a gain margin higher than 6dB in different temperatures (ambient temperature = -40°C, 25°C, and 85°C).
- 12. Frequency is selected considering efficiency and output voltage ripple.
- 13. 100µF (GRM31CR60J107ME39L) ceramic and 470µF (4TPE470MCL) are selected for output capacitors in the evaluation board.
- 14. 3 x 470µF (6TPF470MAH) and 6 x 47µF ceramic (GRM32ER61C476KE15L) are used for input capacitors in the evaluation board.

Table 3. Recommended Input and Output Capacitors

Vendor	Value	Part Number
Panasonic, Input Cap	470 μ F, 6.3V, 2917	6TPF470MAH
Murata, Input Cap	47 μ F, 16V, 1210	GRM32ER61C476KE15L
Murata, Input Cap	47 μ F, 6.3V, 1210	GRM32ER70J476ME20
Taiyo Yuden, Input Ceramic	47 μ F, 16V, 1210	EMK325BJ476MM-T
Murata, Output Ceramic	100 μ F, 6.3V, 1210	GRM31CR60J107ME39L
TDK, Output Ceramic	100 μ F, 6.3V, 1210	C3225X5R0J107M

2. Specifications

2.1 Absolute Maximum Ratings

Parameter	Minimum	Maximum	Unit
Input Supply Voltage, VIN Pin	-0.3	17	V
Input Supply Voltage for Controller, VDD Pin	-0.3	17	V
Input Supply Gate Driver Voltage, VDRV Pin	-0.3	6	V
MOSFET Switch Node Voltage, VSWH Pin	-0.3	25	V
6V Internal Reference Supply Voltage, VR6 Pin	-0.3	6.6	V
5V Internal Reference Supply Voltage, VR5 Pin	-0.3	6.5	V
2.5V Internal Reference Supply Voltage, V25 Pin	-0.3	3	V
Logic I/O Voltage for DDC, EN, MGN, PG, SA, SCL, SDA, SALRT, SYNC, VMON, VSET	-0.3	6.0	V
Analog Input Voltages	Value		
VSEN+, XTEMP+	-0.3	6.0	V
VSEN-, XTEMP-	-0.3	0.3	V
ESD Rating	Value		Unit
Human Body Model (Tested per JESD22-A114F)	2		kV
Machine Model (Tested per JESD22-A115C)	200		V
Charged Device Model (Tested per JESD22-C110D)	750		V
Latch-Up (Tested per JESD78C; Class 2, Level A)	100		mA

CAUTION: Do not operate at or near the maximum ratings listed for extended periods of time. Exposure to such conditions may adversely impact product reliability and result in failures not covered by warranty.

2.2 Thermal Information

Thermal Resistance (Typical)	θ_{JA} (°C/W)	θ_{JC} (°C/W)
40 Ld HDA Module (Notes 15, 16)	8	2.2

Notes:

15. θ_{JA} is measured in free air with the module mounted on an evaluation board 3x4.5inch in size with 2oz surface and 1oz buried planes and multiple via interconnects. The temperature was measured inside the module at the hottest point.
16. For θ_{JC} , the "case temp" location is the center of the package underside.

Parameter	Minimum	Maximum	Unit
Maximum Junction Temperature (Plastic Package)		+125	°C
Storage Temperature Range	-55	+150	°C
Pb-Free Reflow Profile	Refer to TB493		

2.3 Recommended Operating Conditions

Parameter	Minimum	Maximum	Unit
Input Supply Voltage Range, V_{IN}	2.75	4	V
Input Supply Voltage Range for Controller, V_{DD}	4.5	5.5	V
Input Supply Gate Driver Voltage, V_{DRV}	4.5	5.5	V
Output Voltage Range, V_{OUT}	0.6	1.5	V
Output Current Range, $I_{OUT(DC)}$ (Note 19)	0	33	A
Operating Junction Temperature Range, T_J	-40	+125	°C

2.4 Electrical Specifications

$V_{IN} = 3.3V$, $V_{DD} = V_{DRV} = 5V$, $f_{SW} = 533kHz$, $C_{OUT} = 1340\mu F$, $T_A = -40^\circ C$ to $+85^\circ C$, unless otherwise noted. Typical values are at $T_A = +25^\circ C$. **Boldface limits apply across the operating temperature range, $-40^\circ C$ to $+85^\circ C$.**

Parameter	Symbol	Test Conditions	Min (Note 17)	Typ	Max (Note 17)	Unit
Input and Supply Characteristics						
Input Supply Current for Controller	I_{DD}	$V_{IN} = 3.3V$, $V_{DD} = V_{DRV} = 5V$, $V_{OUT} = 0V$, module not enabled		40	50	mA
2.5V Internal Reference Supply Voltage	V_{25}		2.25	2.50	2.75	V
Input Supply Voltage for Controller Readback Resolution	$V_{DD_READ_RES}$			± 20		mV
Input Supply Voltage for Controller Readback Total Error (Note 20)	$V_{DD_READ_ERR}$	PMBus read		± 2		%FS
Output Characteristics						
Output Voltage Adjustment Range	V_{OUT_RANGE}		0.54		2	V
Output Voltage Set-Point Range	V_{OUT_RES}	Configured using PMBus		± 0.025		% V_{OUT}
Output Voltage Set-Point Accuracy (Note 18)	V_{OUT_ACCY}	Includes line, load, and temperature	-1.2		+1.2	%FS
Output Voltage Readback Resolution (Note 20)	$V_{OUT_READ_RES}$			± 0.15		%FS
Output Voltage Readback Total Error (Note 20)	$V_{OUT_READ_ERR}$	PMBus read	-2		+2	%FS
Output Current Readback Resolution	$I_{OUT_READ_RES}$	ISENSE_CONFIG with factory default setting		0.15		A
Output Current Range (Note 19)	I_{OUT_RANGE}				33	A
Output Current Readback Total Error	$I_{OUT_READ_ERR}$	PMBus read at maximum load		± 3		A
Soft-Start and Sequencing						
Delay Time from Enable to V_{OUT} Rise	t_{ON_DELAY}	Configured using PMBus	2		300	ms
t_{ON_DELAY} Accuracy	$t_{ON_DELAY_ACCY}$			± 2		ms
Output Voltage Ramp-Up Time	t_{ON_RISE}	Configured using PMBus	1		120	ms

$V_{IN} = 3.3V$, $V_{DD} = V_{DRV} = 5V$, $f_{SW} = 533kHz$, $C_{OUT} = 1340\mu F$, $T_A = -40^\circ C$ to $+85^\circ C$, unless otherwise noted. Typical values are at $T_A = +25^\circ C$. **Boldface limits apply across the operating temperature range, $-40^\circ C$ to $+85^\circ C$.** (Continued)

Parameter	Symbol	Test Conditions	Min (Note 17)	Typ	Max (Note 17)	Unit
Output Voltage Ramp-Up Time Accuracy	$t_{ON_RISE_ACCY}$			± 250		μs
Delay Time from Disable to V_{OUT} Fall	t_{OFF_DELAY}	Configured using PMBus	2		300	ms
t_{OFF_DELAY} Accuracy	$t_{OFF_DELAY_ACCY}$			± 2		ms
Output Voltage Fall Time	t_{OFF_FALL}	Configured using PMBus	0.5		120	ms
Output Voltage Fall Time Accuracy	$t_{ON_FALL_ACCY}$			± 250		μs
Power-Good						
Power-Good Delay	V_{PG_DELAY}	Configured using PMBus	0		5000	ms
Temperature Sense						
Temperature Sense Range	T_{SENSE_RANGE}	Configurable using PMBus	-50		150	$^\circ C$
Internal Temperature Sensor Accuracy	INT_TEMP_ACCY	Tested at $+100^\circ C$	-5		+5	$^\circ C$
External Temperature Sensor Accuracy	$XTEMP_ACCY$	Using 2N3904 NPN transistor		± 5		$^\circ C$
Fault Protection						
V_{DD} Undervoltage Threshold Range	$V_{DD_UVLO_RANGE}$	Measured internally		4		V
V_{DD} Undervoltage Threshold Accuracy (Note 20)	$V_{DD_UVLO_ACCY}$			± 2		%FS
V_{DD} Undervoltage Response Time	$V_{DD_UVLO_DELAY}$			10		μs
V_{OUT} Overvoltage Threshold Range	$V_{OUT_OV_RANGE}$	Factory default		$1.15V_{OUT}$		V
		Configured using PMBus	$1.05V_{OUT}$		V_{OUT_MAX}	V
V_{OUT} Undervoltage Threshold Range	$V_{OUT_UV_RANGE}$	Factory default		$0.85V_{OUT}$		V
		Configured using PMBus	0		$0.95V_{OUT}$	V
V_{OUT} OV/UV Threshold Accuracy (Note 18)	V_{OUT_OV/UV_ACCY}		-2		+2	%
V_{OUT} OV/UV Response Time	V_{OUT_OV/UV_DELAY}			10		μs
Output Current Limit Set-Point Accuracy (Note 20)	I_{LIMIT_ACCY}	Tested at $I_{OUT_AVG_OC_FAULT_LIMIT} = 40A$		± 10		%FS
Output Current Fault Response Time (Note 21)	I_{LIMIT_DELAY}	Factory default		3		t_{sw}
Over-Temperature Protection Threshold (Controller Junction Temperature)	$T_{JUNCTION}$	Factory default		115		$^\circ C$
		Configured using PMBus	-40		115	$^\circ C$
Thermal Protection Hysteresis	$T_{JUNCTION_HYS}$			15		$^\circ C$
Oscillator and Switching Characteristics						
Switching Frequency Range	f_{SW_RANGE}		296		1067	kHz
Switching Frequency Set-Point Accuracy	f_{SW_ACCY}		-5		+5	%

$V_{IN} = 3.3V$, $V_{DD} = V_{DRV} = 5V$, $f_{SW} = 533kHz$, $C_{OUT} = 1340\mu F$, $T_A = -40^\circ C$ to $+85^\circ C$, unless otherwise noted. Typical values are at $T_A = +25^\circ C$. **Boldface limits apply across the operating temperature range, $-40^\circ C$ to $+85^\circ C$.** (Continued)

Parameter	Symbol	Test Conditions	Min (Note 17)	Typ	Max (Note 17)	Unit
Minimum Pulse Width Required from External SYNC Clock	EXT_SYNC _{PW}	Measured at 50% amplitude	150			ns
Drift Tolerance for External SYNC Clock	EXT_SYNC _{DRIFT}		-10		+10	%
Logic Input/Output Characteristics						
Bias Current at the Logic Input Pins	I _{LOGIC_BIAS}	DDC, EN, MGN, PG, SA, SCL, SDA, SALRT, SYNC, VMON, VSET	-100		+100	nA
Logic Input Low Threshold Voltage	V _{LOGIC_IN_LOW}				0.8	V
Logic Input High Threshold Voltage	V _{LOGIC_IN_HIGH}		2.0			V
Logic Output Low Threshold Voltage	V _{LOGIC_OUT_LOW}	2mA sinking			0.5	V
Logic Output High Threshold Voltage	V _{LOGIC_OUT_HIGH}	2mA sourcing	2.25			V
PMBus Interface Timing Characteristic						
PMBus Operating Frequency	f _{SMB}		100		400	kHz

Notes:

17. Compliance to datasheet limits is assured by one or more methods: production test, characterization, and/or design.
18. V_{OUT} measured at the termination of the VSEN+ and VSEN- sense points.
19. The MAX load current is determined by the thermal ["Typical Performance Curves" on page 14](#) provided with this document.
20. "FS" stands for full scale of the recommended maximum operating range.
21. "tSW" stands for time period of operation switching frequency.

3. Typical Performance Curves

Operating Conditions: $V_{IN} = 3.3V$, $V_{DD} = V_{DRV} = 5V$, $T_A = +25^\circ C$, no airflow, typical values are used unless otherwise noted. I_{OUT} derating curves were plotted at $T_J = +115^\circ C$

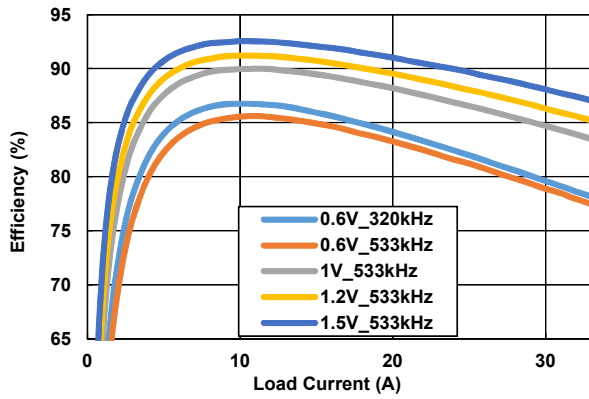

Figure 5. Efficiency vs Output Current at $V_{IN} = 3.3V$, for Various Output Voltages

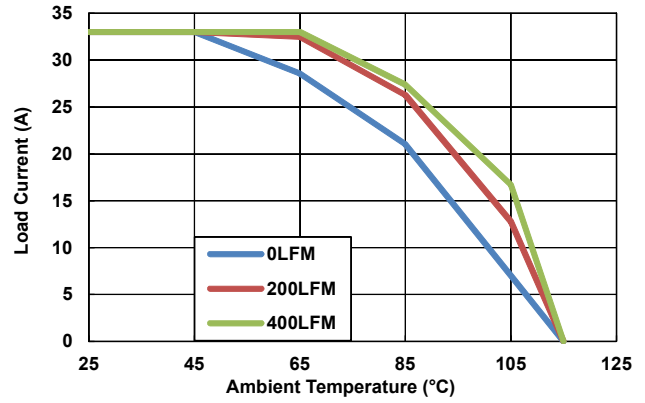

Figure 6. Derating Curve $3.3V_{IN}$ to $1.2V_{OUT}$, 533kHz

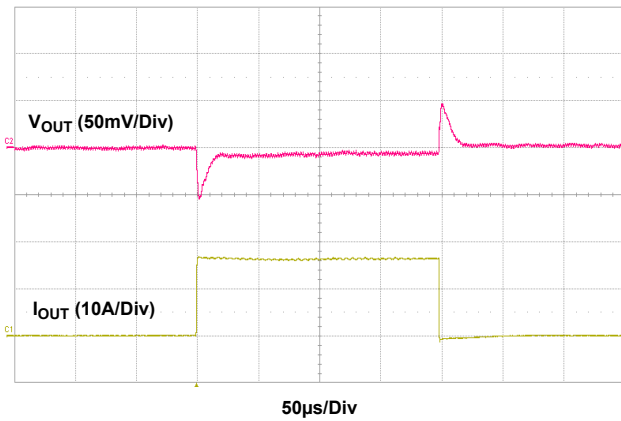

Figure 7. Transient Response (0A to 16.5A, $>15A/\mu s$), $3.3V_{IN}$ to $1.5V_{OUT}$, 533kHz

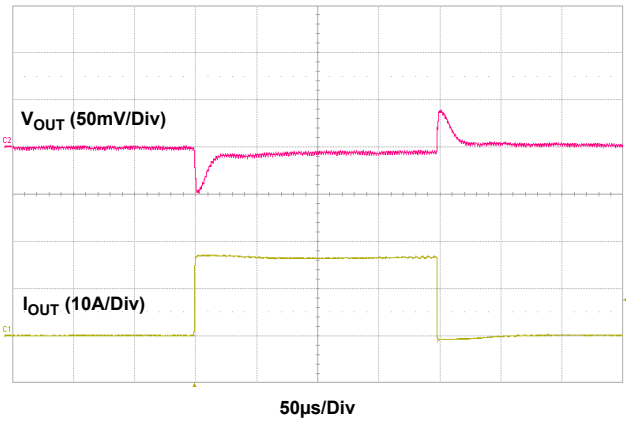

Figure 8. Transient Response (0A to 16.5A, $>15A/\mu s$), $3.3V_{IN}$ to $1.2V_{OUT}$, 533kHz

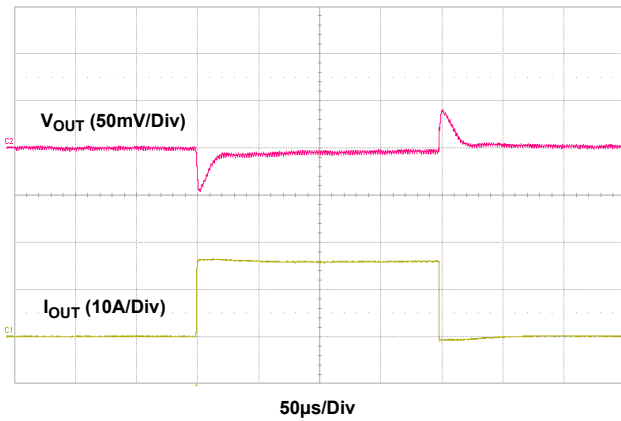

Figure 9. Transient Response (0A to 16.5A, $>15A/\mu s$), $3.3V_{IN}$ to $1.0V_{OUT}$, 533kHz

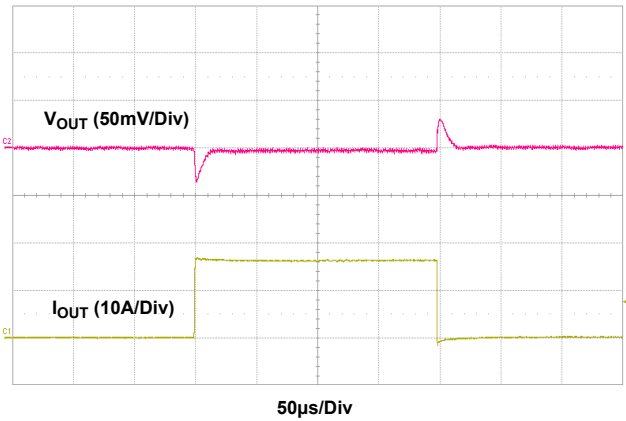

Figure 10. Transient Response (0A to 16.5A, $>15A/\mu s$), $3.3V_{IN}$ to $0.6V_{OUT}$, 533kHz

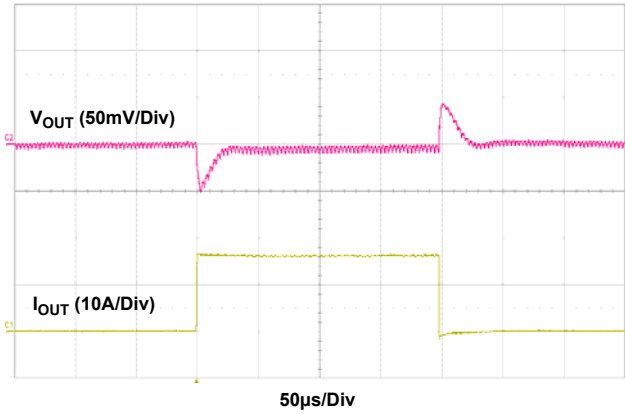

Figure 11. Transient Response (0A to 16.5A, >15A/μs), 3.3V_{IN} to 0.6V_{OUT}, 320kHz

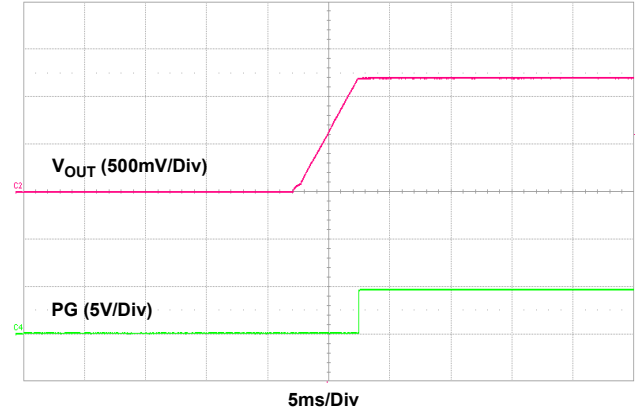

Figure 12. Startup, 3.3V_{IN} to 1.2V_{OUT}, 0A

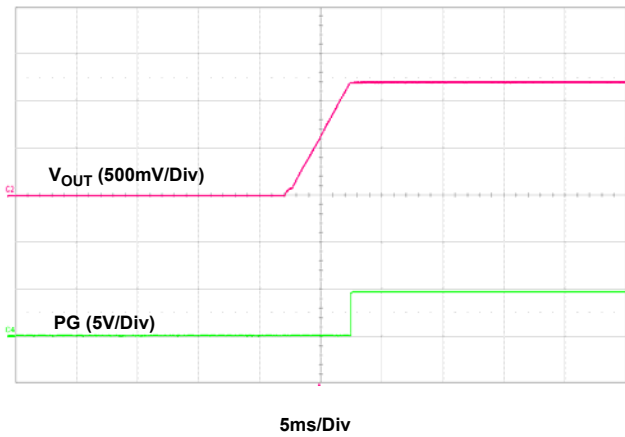

Figure 13. Startup, 3.3V_{IN} to 1.2V_{OUT}, 33A

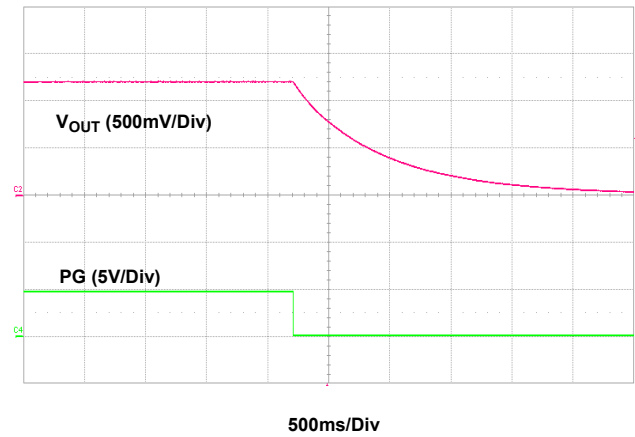

Figure 14. Immediate Shutdown, 3.3V_{IN} to 1.2V_{OUT}, 0A

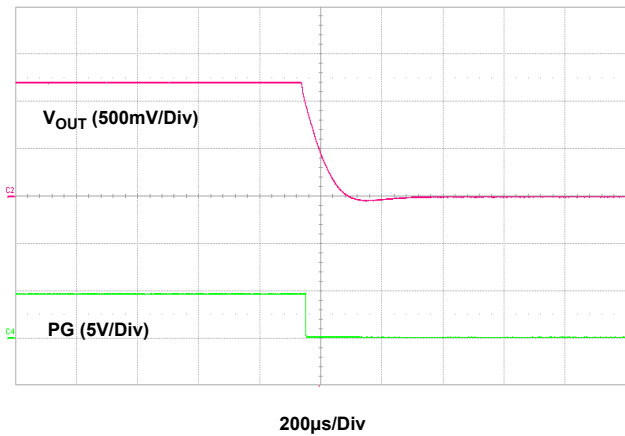

Figure 15. Immediate Shutdown, 3.3V_{IN} to 1.2V_{OUT}, 33A

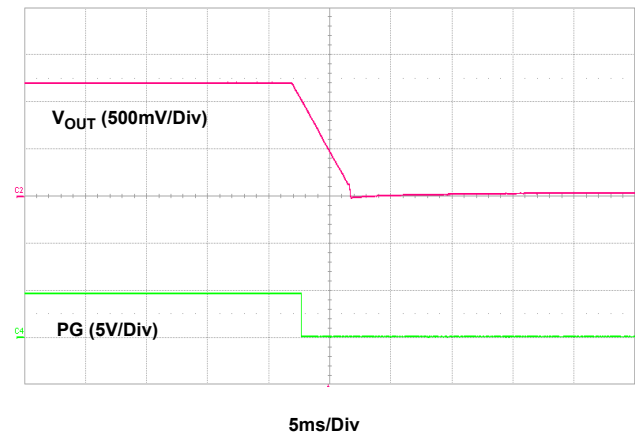

Figure 16. Soft-Off, 3.3V_{IN} to 1.2V_{OUT}, 33A

4. Functional Description

4.1 SMBus Communications

The ZL9024M provides an SMBus digital interface that enables the user to configure all aspects of the module operation as well as monitor the input and output parameters. The ZL9024M can be used with any SMBus host device. In addition, the module is compatible with PMBus Power System Management Protocol Specification Parts I and II version 1.2. The ZL9024M accepts most standard PMBus commands. When controlling the device with PMBus commands, it is recommended that the enable pin be tied to SGND.

The SMBus device address is the only parameter that must be set by external pins. All other device parameters can be set with PMBus commands.

4.2 Output Voltage Selection

The output voltage can be set to a voltage between 0.6V and 1.5V if the input voltage is higher than the desired output voltage by an amount sufficient to maintain regulation.

The VSET pin is used to set the output voltage to levels as shown in [Table 4](#). The R_{SET} resistor is placed between the VSET pin and SGND. A standard 1% resistor is recommended.

Table 4. Output Voltage Resistor Settings

V_{OUT} (V)	R_{SET} (k Ω)
0.60	10
0.65	11
0.70	12.1
0.75	13.3
0.80	14.7
0.85	16.2
0.90	17.8
0.95	19.6
1.00	21.5, or connect to SGND
1.05	23.7
1.10	26.1
1.15	28.7
1.20	31.6, or OPEN
1.25	34.8
1.30	38.3
1.40	42.2
1.50	46.4

The output voltage can also be set to any value between 0.6V and 1.5V using the PMBus command `VOUT_COMMAND`.

By default, V_{OUT_MAX} is set 110% higher than V_{OUT} set by the pin-strap resistor, which can be changed to any value up to 2V with the PMBus command `VOUT_MAX`.

4.3 Soft-Start Delay and Ramp Times

It may be necessary to set a delay from when an enable signal is received until the output voltage starts to ramp to its target value. In addition, the designer may wish to precisely set the time required for V_{OUT} to ramp to its target value after the delay period has expired. These features can be used as part of an overall inrush current management strategy or to precisely control how fast a load IC is turned on. The ZL9024M gives the system designer several options for precisely and independently controlling both the delay and ramp time periods. The soft-start delay period begins when the EN pin is asserted and ends when the delay time expires.

The soft-start delay and ramp times can be programmed to custom values with the PMBus commands TON_DELAY and TON_RISE. When the delay time is set to 0ms, the device begins its ramp-up after the internal circuitry has initialized (approximately 2ms). When the soft-start ramp period is set to 0ms, the output ramps up as quickly as the output load capacitance and loop settings allow. It is generally recommended to set the soft-start ramp to a value greater than 500 μ s to prevent inadvertent fault conditions due to excessive inrush current.

4.4 Power-Good

The ZL9024M provides a Power-Good (PG) signal that indicates the output voltage is within a specified tolerance of its target level and no fault condition exists. By default, the PG pin asserts if the output is within 10% of the target voltage. These limits and the polarity of the pin can be changed with the PMBus command POWER_GOOD_ON.

A PG delay period is defined as the time from when all conditions within the ZL9024M for asserting PG are met to when the PG pin is actually asserted. This feature is commonly used instead of using an external reset controller to control external digital logic. A PG delay can be programmed with the PMBus command POWER_GOOD_DELAY.

4.5 Switching Frequency and PLL

The device's switching frequency is set from 296kHz to 1067kHz using the pin-strap method as shown in [Table 5 on page 17](#), or by using the PMBus command FREQUENCY_SWITCH. The ZL9024M incorporates an internal Phase-Locked Loop (PLL) to clock the internal circuitry. The PLL can be driven by an external clock source connected to the SYNC pin. When using the internal oscillator, the SYNC pin can be configured as a clock source as a external sync to other modules. Refer to the SYNC_CONFIG command on [page 60](#) for more information.

Table 5. Switching Frequency Resistor Settings

f_{sw} (kHz)	R_{SET} (k Ω)
296	14.7, or connect to SGND
320	16.2
364	17.8
400	19.6
421	21.5
471	23.7
533	26.1, or OPEN
571	28.7
615	31.6
727	34.8
800	38.3
842	42.2
889	46.4
1067	51.1, or connect to V25

4.6 Loop Compensation

The module is internally compensated using the PMBus command ASCR_CONFIG. The ZL9024M uses the ChargeMode control algorithm that responds to output current changes within a single PWM switching cycle, achieving a smaller total output voltage variation with less output capacitance than traditional PWM controllers.

4.7 Undervoltage Lockout (UVLO)

The VDD Undervoltage Lockout (UVLO) prevents the ZL9024M from operating when the VDD falls below a preset threshold, indicating the driver voltage is out of its specified range. The input UVLO threshold prevents the ZL9024M from operating when the input supply voltage, V_{IN} , falls below a preset threshold, which can be changed by using the PMBus command VIN_UV_FAULT_LIMIT.

VDD needs to be higher than VDRV_UV_WARN_LIMIT for the module to start up. During startup, apply the V_{IN} supply before the VDD bias voltage. Otherwise, the device may declare an input undervoltage fault condition.

4.8 SMBus Module Address Selection

Each module must have its own unique serial address to distinguish between other devices on the bus. The module address is set by connecting a resistor between the SA pin and SGND. [Table 6](#) lists the available module addresses.

Table 6. SMBus Address Resistor Selection

R_{SA} (k Ω)	SMBus Address
10	19h
11	1Ah
12.1	1Bh
13.3	1Ch
14.7	1Dh
16.2	1Eh
17.8	1Fh
19.6	20h
21.5	21h
23.7	22h
26.1	23h
28.7	24h
31.6	25h
34.8, or connect to SGND	26h
38.3	27h
42.2, or Open	28h
46.4	29h
51.1	2Ah
56.2	2Bh
61.9	2Ch
68.1	2Dh
75	2Eh
82.5	2Fh
90.9	30h
100	31h

4.9 Output Overvoltage Protection

The ZL9024M offers an internal output overvoltage protection circuit that can be used to protect sensitive load circuitry from being subjected to a voltage higher than its prescribed limits. A hardware comparator is used to compare the actual output voltage (seen at the VSEN+, VSEN- pins) to a threshold set to 15% higher than the target output voltage (the default setting). Fault threshold can be programmed to a desired level with the PMBus command VOUT_OV_FAULT_LIMIT. If the VSEN+ voltage exceeds this threshold, the module will initiate an immediate shutdown without retry. Retry settings can be programmed with the PMBus command VOUT_OV_FAULT_RESPONSE.

Internal to the module, two 100Ω resistors are populated from VOUT to VSEN+ and SGND to VSEN- to protect from overvoltage conditions in case remote sense traces are not present or accidentally open. As long as differential remote sense traces have low resistance, V_{OUT} regulation accuracy is not sacrificed.

4.10 Output Prebias Protection

An output prebias condition exists when an externally applied voltage is present on a power supply's output before the power supply's control IC is enabled. Certain applications require that the converter not be allowed to sink current during start-up if a prebias condition exists at the output. The ZL9024M provides prebias protection by sampling the output voltage prior to initiating an output ramp.

If a prebias voltage lower than the target voltage exists after the preconfigured delay period has expired, the target voltage is set to match the existing prebias voltage, and both drivers are enabled. The output voltage is then ramped to the final regulation value at the preconfigured ramp rate.

The actual time the output takes to ramp from the prebias voltage to the target voltage varies, depending on the prebias voltage, however, the total time elapsed from when the delay period expires and when the output reaches its target value will match the preconfigured ramp time (see [Figure 17](#)).

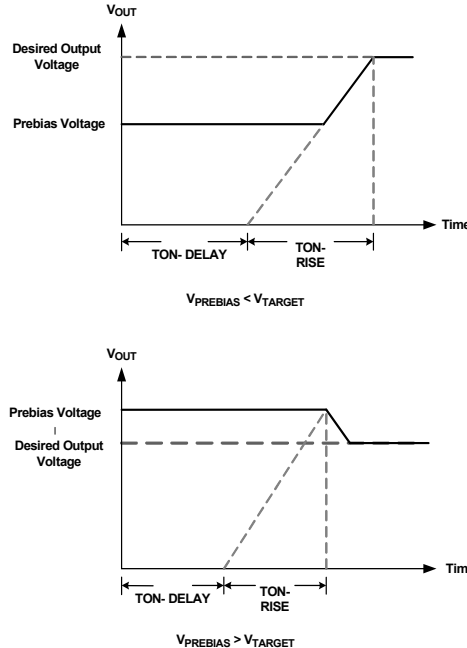

Figure 17. Output Responses to Prebias Voltages

If a prebias voltage is higher than the target voltage after the preconfigured delay period has expired, the target voltage is set to match the existing prebias voltage, and both drivers are enabled with a PWM duty cycle that would ideally create the prebias voltage.

When the preconfigured soft-start ramp period has expired, the PG pin is asserted (assuming the prebias voltage is not higher than the overvoltage limit). The PWM then adjusts its duty cycle to match the original target voltage, and the output ramps down to the preconfigured output voltage.

If a prebias voltage is higher than the overvoltage limit, the device does not initiate a turn-on sequence and declares an overvoltage fault condition. The device then responds based on the output overvoltage fault response setting programmed with the PMBus command `VOUT_OV_FAULT_RESPONSE`.

4.11 Output Overcurrent Protection

The ZL9024M is protected from damage if the output is shorted to ground or if an overload condition is imposed on the output. The average output overcurrent fault threshold can be programmed by the PMBus command `IOUT_AVG_OC_FAULT_LIMIT` while the peak output overcurrent fault threshold can be programmed by the PMBus command `IOUT_OC_FAULT_LIMIT`. The default response from an average overcurrent fault is an immediate shutdown without retry. A continuous retry can be enabled using the PMBus command `MFR_IOUT_OC_FAULT_RESPONSE`.

4.12 Thermal Overload Protection

The ZL9024M includes a thermal sensor that continuously measures the internal temperature of the module and shuts down the controller when the temperature exceeds the preset limit. The default temperature limit is set to +115°C in the factory, but can be changed with the PMBus command `OT_FAULT_LIMIT`. Note that the temperature reading from the PMBus command is the temperature of the internal controller, which is lower than the junction temperature of the module.

The default response from an over-temperature fault is an immediate shutdown without retry. Retry settings can be programmed with the PMBus command `OT_FAULT_RESPONSE`.

If the user has configured the module to retry, the controller waits the preset delay period (if configured to do so) and then checks the module temperature. If the temperature has dropped below a threshold that is approximately +15°C lower than the selected temperature fault limit, the controller attempts to restart. If the temperature still exceeds the fault limit, the controller waits the preset delay period and retries again.

4.13 Digital-DC Bus

The Digital-DC Communications (DDC) bus is used to communicate between Renesas digital power modules and digital controllers. This dedicated bus provides the communication channel between devices for features such as sequencing and fault spreading. The DDC pin on all Digital-DC devices in an application should be connected together. A pull-up resistor is required on the DDC bus in order to guarantee the rise time, as shown in [Equation 1](#):

$$(EQ. 1) \quad \text{Rise Time} = R_{PU} * C_{LOAD} \approx 1 \mu\text{s}$$

Where R_{PU} is the DDC bus pull-up resistance and C_{LOAD} is the bus loading. The pull-up resistor can be tied to an external 3.3V or 5V supply as long as this voltage is present prior to or during device power-up. In principle, each device connected to the DDC bus presents approximately 10pF of capacitive loading, and each inch of FR4 PCB trace introduces approximately 2pF. The ideal design uses a central pull-up resistor that is well-matched to the total load capacitance.

4.14 Phase Spreading

When multiple point-of-load converters share a common DC input supply, it is desirable to adjust the clock phase offset of each device, such that not all devices start to switch simultaneously. Setting each converter to start its switching cycle at a different point in time, can dramatically reduce input capacitance requirements and efficiency losses. Because the peak current drawn from the input supply is effectively spread out over a period of time, the peak current drawn at any given moment is reduced, and the power losses proportional to the I_{RMS}^2 are reduced dramatically.

To enable phase spreading, all converters must be synchronized to the same switching clock. The phase offset of each device can also be set to any value between 0° and 360° in 22.5° increments with the PMBus command INTERLEAVE.

4.15 Output Sequencing

A group of Digital-DC modules or devices can be configured to power-up in a predetermined sequence. This feature is especially useful when powering advanced processors, (FPGAs and ASICs that require one supply to reach its operating voltage) prior to another supply reaching its operating voltage in order to avoid latch-up. Multidevice sequencing can be achieved by configuring each device with the PMBus command SEQUENCE. Multiple device sequencing is configured by issuing PMBus commands to assign the preceding device in the sequencing chain as well as the device that follows in the sequencing chain.

The Enable pins of all devices in a sequencing group must be tied together and driven high to initiate a sequenced turn-on of the group. Enable must be driven low to initiate a sequenced turnoff of the group.

4.16 Fault Spreading

Digital DC modules and devices can be configured to broadcast a fault event over the DDC bus to the other devices in the group with the PMBus command DDC_GROUP. When a non-destructive fault occurs and the device is configured to shut down on a fault, the device shuts down and broadcasts the fault event over the DDC bus. The other devices on the DDC bus shut down simultaneously, if configured to do so, and attempt to restart in their prescribed order.

4.17 Temperature Monitoring Using the XTEMP Pin

The ZL9024M supports measurement of an external device temperature using either a thermal diode integrated in a processor, FPGA or ASIC, or using a discrete diode-connected 2N3904 NPN transistor. [Figure 18](#) illustrates the typical connections required. The external temperature sensors can be used to provide the temperature reading for over-temperature and under-temperature faults. These options for the external temperature sensors are enabled using the USER_CONFIG PMBus command.



Figure 18. External Temperature Monitoring

4.18 Monitoring Using SMBus

A system controller can monitor a wide variety of different ZL9024M system parameters with PMBus commands:

- READ_VIN
- READ_VOUT
- READ_IOUT
- READ_TEMPERATURE_1
- READ_TEMPERATURE_2
- READ_DUTY_CYCLE
- READ_FREQUENCY
- READ_VDRV

4.19 Snapshot Parameter Capture

The ZL9024M offers a special feature that enables the user to capture parametric data and some fault statuses during normal operation or following a fault. A detailed description is provided in [“PMBus Commands Description” on page 33](#) under the PMBus command SNAPSHOT and SNAPSHOT_CONTROL.

4.20 Non-Volatile Memory

The ZL9024M has internal non-volatile memory that stores user configurations. Integrated security measures ensure that the user can only restore the module to a level that has been made available to them. During the initialization process, the ZL9024M checks for stored values contained in its internal non-volatile memory.

Modules are shipped with factory defaults configuration and most settings can be overwritten with PMBus Commands and can be stored in non-volatile memory with the PMBus command STORE_USER_ALL.

5. PCB Layout Guidelines

To achieve stable operation, low losses, and good thermal performance, some layout considerations are necessary.

- Establish separate SGND and PGND planes, then connect SGND to the PGND plane as shown in [Figure 20 on page 24](#) in the middle layer. For making connections between SGND/PGND on the top layer and other layers, use multiple vias for each pin to connect to the inner SGND/PGND layer. Do not connect SGND directly to PGND on a top layer. Connecting SGND directly to PGND without establishing an SGND plane will bypass the decoupling capacitor at internal reference supplies, making the controller susceptible to noise.
- Place enough ceramic capacitors between VIN and PGND, VOUT and PGND, and bypass capacitors between VDD and the ground plane, as close to the module as possible to minimize high frequency noise.
- Use large copper areas for the power path (VIN, PGND, VOUT) to minimize conduction loss and thermal stress. Also, use multiple vias to connect the power planes in different layers. Extra ceramic capacitors at VIN and VOUT can be placed on the bottom layer under the VIN and VOUT pads when multiple vias are used for connecting copper pads on top and bottom layers.
- Connect differential remote sensing traces to the regulation point to achieve a tight output voltage regulation. Route a trace from VSEN+ to the point-of-load where the tight output voltage is desired. Avoid routing any sensitive signal traces, such as the VSENSE signal near the VSWH pads.
- Connect differential remote sensing traces to the external temperature sensing point. Keep the traces as short as possible. If applicable, place the trace in the inner layer with the ground plane on the layer immediately below and on top of the traces.
- For noise sensitive applications, it is recommended to connect VSWH pads only on the top layer; however, thermal performance is sacrificed. External airflow might be required to keep module heat at the desired level. For applications in which switching noise is less critical, an excellent thermal performance can be achieved in the ZL9024M module by increasing copper mass attached to the VSWH pad. To increase copper mass on the VSWH node, create copper islands in the middle and bottom layers under the VSWH pad and connect them to the top layer with multiple vias. Shield those copper islands with a PGND layer to avoid any interference to noise sensitive signals.

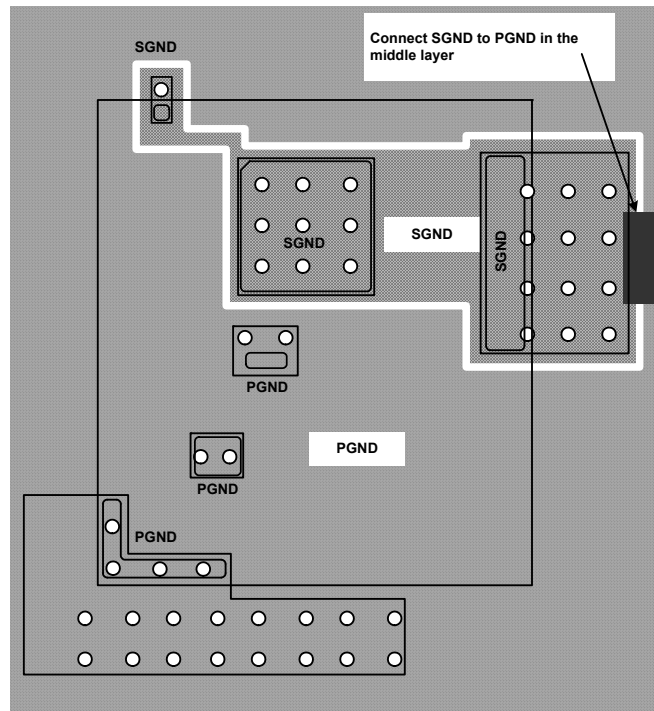
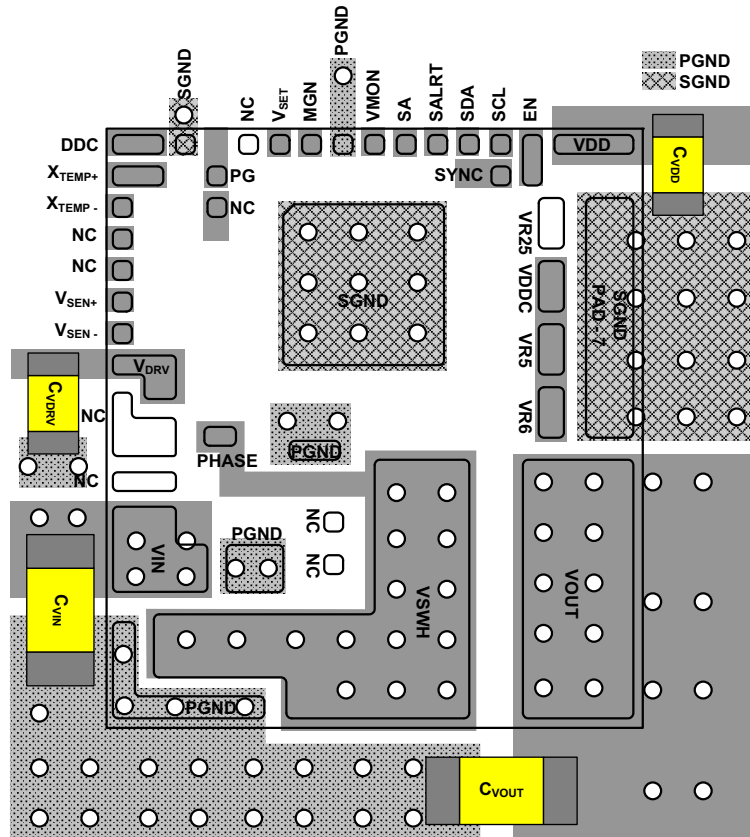

Figure 20. Recommended Layout - Connect SGND to PGND in the Middle PCB Layer After Establishing Separate SGND and PGND

6. Thermal Considerations

Experimental power loss curves along with θ_{JA} from thermal modeling analysis can be used to evaluate the thermal consideration for the module. The derating curves are derived from the maximum power allowed while maintaining the temperature below the maximum junction temperature of +125°C. In actual application, other heat sources and design margin should be considered.

The READ_INTERNAL_TEMP command value in PowerNavigator is the temperature reading value of the internal controller. The junction temperature of the power stage in the module may be higher than the READ_INTERNAL_TEMP command value. The temperature difference depends on the operating conditions; in some extreme cases, the junction temperature of the power stage can be 30°C higher than the READ_INTERNAL_TEMP command value.

6.1 Package Description

The structure of the ZL9024M belongs to the High Density Array (HDA) no-lead package. This kind of package has advantages such as good thermal and electrical conductivity, low weight, and small size. The HDA package is applicable for surface mounting technology and is being more readily used in the industry. The ZL9024M contains several types of devices, including resistors, capacitors, inductors, and control ICs. The ZL9024M is a copper lead-frame based package with exposed copper thermal pads, which have good electrical and thermal conductivity. The copper lead frame and multicomponent assembly is over-molded with polymer mold compound to protect these devices.

The package outline, a typical PCB land pattern design and a typical stencil opening edge position are shown on pages 65, 68, and 70 respectively. The module has a small size of 17mmx19mmx3.55mm. [Figure 21 on page 26](#) shows typical reflow profile parameters. These guidelines are general design rules. Users can modify parameters according to their application.

6.2 PCB Layout Pattern Design

The bottom of the ZL9024M is a lead-frame footprint, which is attached to the PCB by a surface mounting process. The PCB layout pattern is shown starting on [page 65](#). The PCB layout pattern is an array of solder mask defined PCB lands which align with the perimeters of the HDA exposed pads and I/O termination dimensions. The thermal lands on the PCB layout also feature an array of solder mask defined lands and should match 1:1 with the package exposed die pad perimeters. The exposed solder mask defined PCB land area should be 50-80% of the available module I/O area.

6.3 Thermal Vias

A grid of 1.0mm to 1.2mm pitch thermal vias, which drops down and connects to buried copper plane(s), should be placed under the thermal land. The vias should be about 0.3mm to 0.33mm in diameter with the barrel plated to about 1.0 ounce copper. Although adding more vias (by decreasing via pitch) will improve the thermal performance, diminishing returns will be seen as more and more vias are added. Simply use as many vias as practical for the thermal land size and your board design rules allow.

6.4 Stencil Pattern Design

Reflowed solder joints on the perimeter I/O lands should have about a 50µm to 75µm (2 mil to 3 mil) standoff height. The solder paste stencil design is the first step in developing optimized, reliable solder joints.

Stencil aperture size to solder mask defined PCB land size ratio should typically be 1:1. The aperture width can be reduced slightly to help prevent solder bridging between adjacent I/O lands. A typical solder stencil pattern is shown in the [Package Outline Drawing](#) section starting on [page 65](#). The user should consider the symmetry of the whole stencil pattern when designing its pads. A laser cut, stainless steel stencil with electropolished trapezoidal walls is recommended. Electropolishing “smooths” the aperture walls resulting in reduced surface friction and better paste release, which reduces voids. Using a Trapezoidal Section Aperture (TSA) also promotes paste release and forms a “brick like” paste deposit that assists in firm component placement. A 0.1mm to 0.15mm stencil thickness is recommended for this large pitch HDA.

6.5 Reflow Parameters

Due to the low mount height of the HDA, "No Clean" Type 3 solder paste per ANSI/J-STD-005 is recommended. Nitrogen purge is also recommended during reflow. A system board reflow profile depends on the thermal mass of the entire populated board, thus it is not practical to define a specific soldering profile just for the HDA. The profile given in [Figure 21](#) is provided as a guideline, to be customized for varying manufacturing practices and applications.

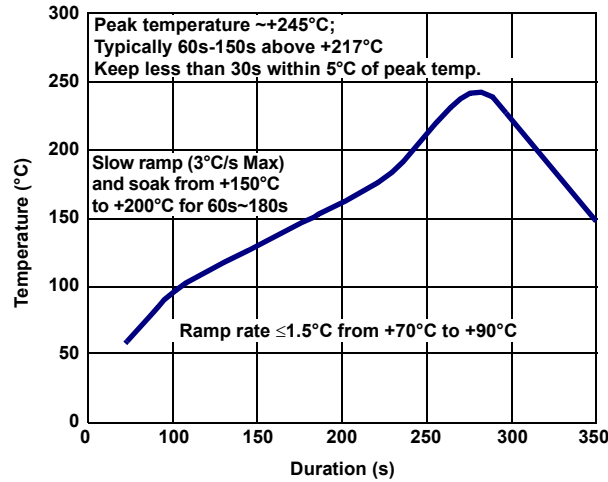

Figure 21. Typical Reflow Profile

7. PMBus Command Summary

Command Code	Command Name	Description	Type	Data Format	Default Value	Default Setting	Page
01h	OPERATION	Sets Enable, Disable, and V_{OUT} Margin modes.	R/W Byte	BIT			33
02h	ON_OFF_CONFIG	Configures the EN pin and PMBus commands to turn the unit ON/OFF	R/W Byte	BIT	17h	Hardware Enable, Immediate Off	33
03h	CLEAR_FAULTS	Clears fault indications.	SEND Byte				33
15h	STORE_USER_ALL	Stores all PMBus values written since last restore at user level.	SEND Byte				34
16h	RESTORE_USER_ALL	Restores PMBus settings that were stored using STORE_USER_ALL.	SEND Byte				34
20h	VOUT_MODE	Preset to defined data format of V_{OUT} commands.	READ Byte	BIT	13h	Linear Mode, Exponent = -13	34
21h	VOUT_COMMAND	Sets the nominal value of the output voltage.	R/W Word	L16u		Pin-Strap	34
23h	VOUT_CAL_OFFSET	Applies a fixed offset voltage to the VOUT_COMMAND.	R/W Word	L16s	0000h	0V	35
24h	VOUT_MAX	Sets the maximum possible value of V_{OUT} . 110% of pin-strap V_{OUT} .	R/W Word	L16u		1.1 * VOUT Pin-Strap	35
25h	VOUT_MARGIN_HIGH	Sets the value of the V_{OUT} during a margin high.	R/W Word	L16u		1.05 * VOUT Pin-Strap	35
26h	VOUT_MARGIN_LOW	Sets the value of the V_{OUT} during a margin low.	R/W Word	L16u		0.95 * VOUT Pin-Strap	35
27h	VOUT_TRANSITION_RATE	Sets the transition rate during margin or other change of V_{OUT} .	R/W Word	L11	BA00h	1V/ms	36
28h	VOUT_DROOP	Sets the loadline (V/I Slope) resistance for the rail.	R/W Word	L11	0000h	0mV/A	36
33h	FREQUENCY_SWITCH	Sets the switching frequency.	R/W Word	L11		Pin-Strap	36
37h	INTERLEAVE	Configures a phase offset between devices sharing a SYNC clock.	R/W Word	BIT		Set based on PMBus Address	37
38h	IOUT_CAL_GAIN	Sense resistance for inductor DCR current sensing.	R/W Word	L11	B29Ah	0.65m Ω	37
39h	IOUT_CAL_OFFSET	Sets the current-sense offset.	R/W Word	L11	0000h	0A	37
40h	VOUT_OV_FAULT_LIMIT	Sets the V_{OUT} overvoltage fault threshold.	R/W Word	L16u		1.15 * VOUT Pin-Strap	38
41h	VOUT_OV_FAULT_RESPONSE	Configures the V_{OUT} overvoltage fault response.	R/W Byte	BIT	80h	Disable and No Retry	38
42h	VOUT_OV_WARN_LIMIT	Sets the V_{OUT} overvoltage warn threshold.	R/W Word	L16u		1.10 * VOUT Pin-Strap	38
43h	VOUT_UV_WARN_LIMIT	Sets the V_{OUT} undervoltage warn threshold.	R/W Word	L16u		0.90 * VOUT Pin-Strap	39
44h	VOUT_UV_FAULT_LIMIT	Sets the V_{OUT} undervoltage fault threshold.	R/W Word	L16u		0.85 * VOUT Pin-Strap	39

Command Code	Command Name	Description	Type	Data Format	Default Value	Default Setting	Page
45h	VOUT_UV_FAULT_RESPONSE	Configures the V_{OUT} undervoltage fault response.	R/W Byte	BIT	80h	Disable and No Retry	39
46h	IOOUT_OC_FAULT_LIMIT	Sets the I_{OUT} peak overcurrent fault threshold.	R/W Word	L11	E341h	52.062A	40
4Bh	IOOUT_UC_FAULT_LIMIT	Sets the I_{OUT} peak undercurrent fault threshold.	R/W Word	L11	E58Fh	-39.062A	40
4Fh	OT_FAULT_LIMIT	Sets the over-temperature fault threshold.	R/W Word	L11	EB98h	+115°C	40
50h	OT_FAULT_RESPONSE	Configures the over-temperature fault response.	R/W Byte	BIT	80h	Disable and No Retry	41
51h	OT_WARN_LIMIT	Sets the over-temperature warning limit.	R/W Word	L11	EB48h	105°C	41
52h	UT_WARN_LIMIT	Sets the under-temperature warning limit.	R/W Word	L11	E580h	-40°C	41
53h	UT_FAULT_LIMIT	Sets the under-temperature fault threshold.	R/W Word	L11	E4E0h	-50°C	42
54h	UT_FAULT_RESPONSE	Configures the under-temperature fault response.	R/W Byte	BIT	80h	Disable and No Retry	42
55h	VDRV_OV_FAULT_LIMIT	Sets the VDRV overvoltage fault threshold.	READ Word	L11	CB00h	6V	42
56h	VDRV_OV_FAULT_RESPONSE	Configures the VDRV overvoltage fault response.	READ Byte	BIT	80h	Disable and No Retry	42
57h	VDRV_OV_WARN_LIMIT	Sets the VDRV overvoltage warning limit.	READ Word	L11	CAC0h	5.5V	43
58h	VDRV_UV_WARN_LIMIT	Sets the VDRV undervoltage warning limit.	READ Word	L11	CA40h	4.5V	43
59h	VDRV_UV_FAULT_LIMIT	Sets the VDRV undervoltage fault threshold.	READ Word	L11	CA00h	4V	43
5Ah	VDRV_UV_FAULT_RESPONSE	Configures the VDRV undervoltage fault response.	READ Byte	BIT	80h	Disable and No Retry	43
5Eh	POWER_GOOD_ON	Sets the voltage threshold for Power-Good indication.	R/W Word	L16u		$0.9 * V_{OUT}$ Pin-Strap	44
60h	TON_DELAY	Sets the delay time from ENABLE to start of V_{OUT} rise.	R/W Word	L11	CA80h	5ms	44
61h	TON_RISE	Sets the rise time of V_{OUT} after ENABLE and TON_DELAY.	R/W Word	L11	CA80h	5ms	44
64h	TOFF_DELAY	Sets the delay time from DISABLE to start of V_{OUT} fall.	R/W Word	L11	CA80h	5ms	44
65h	TOFF_FALL	Sets the fall time for V_{OUT} after DISABLE and TOFF_DELAY.	R/W Word	L11	CA80h	5ms	45
78h	STATUS_BYTE	Returns an abbreviated status for fast reads.	READ Byte	BIT	00h	No Faults	45
79h	STATUS_WORD	Returns information with a summary of the unit's fault condition.	READ Word	BIT	0000h	No Faults	46

Command Code	Command Name	Description	Type	Data Format	Default Value	Default Setting	Page
7Ah	STATUS_VOUT	Returns the V_{OUT} specific status.	READ Byte	BIT	00h	No Faults	47
7Bh	STATUS_IOUT	Returns the I_{OUT} specific status.	READ Byte	BIT	00h	No Faults	47
7Ch	STATUS_VDRV	Returns specific status specific to the VDRV.	READ Byte	BIT	00h	No Faults	48
7Dh	STATUS_TEMPERATURE	Returns the temperature specific status.	READ Byte	BIT	00h	No Faults	48
7Eh	STATUS_CML	Returns the Communication, Logic and Memory specific status.	READ Byte	BIT	00h	No Faults	49
80h	STATUS_INPUT	Returns the V_{IN} and External Sync clock specific status.	READ Byte	BIT	00h	No Faults	49
88h	READ_VDRV	Returns the driver voltage reading.	READ Word	L11			50
8Bh	READ_VOUT	Returns the output voltage reading.	READ Word	L16u			50
8Ch	READ_IOUT	Returns the output current reading.	READ Word	L11			50
8Dh	READ_TEMPERATURE_1	Returns the temperature reading internal to the device.	READ Word	L11			50
8Eh	READ_TEMPERATURE_2	Returns the temperature reading from external monitor source.	READ Word	L11			50
94h	READ_DUTY_CYCLE	Returns the duty cycle reading during the ENABLE state.	READ Word	L11			50
95h	READ_FREQUENCY	Returns the measured operating switch frequency.	READ Word	L11			50
99h	MFR_ID	Sets a user defined identification.	R/W Block	ASC		Null	51
9Ah	MFR_MODEL	Sets a user defined model.	R/W Block	ASC		Null	51
9Bh	MFR_REVISION	Sets a user defined revision.	R/W Block	ASC		Null	51
9Ch	MFR_LOCATION	Sets a user defined location identifier.	R/W Block	ASC		Null	52
9Dh	MFR_DATE	Sets a user defined date.	R/W Block	ASC		Null	52
9Eh	MFR_SERIAL	Sets a user defined serialized identifier.	R/W Block	ASC		Null	52
A8h	LEGACY_FAULT_GROUP	Sets rail IDs of legacy devices for fault spreading.	R/W Block	BIT	0000000h	No rail ID specified	52
ADh	IC_DEVICE_ID	Reports device identification information	READ Block	CUS	49B01500h	Renesas ZL9024M	53
B0h	USER_DATA_00	Sets a user defined data.	R/W Block	ASC		Null	53
D0h	ISENSE_CONFIG	Configures ISENSE related features.	R/W Byte	BIT	25h	256ns Blanking Time, Mid Range	53
D1h	USER_CONFIG	Configures several user-level features.	R/W Byte	BIT	00h	Open Drain PG, XTEMP Disabled	54

Command Code	Command Name	Description	Type	Data Format	Default Value	Default Setting	Page
D3h	DDC_CONFIG	Configures the DDC bus.	R/W Word	BIT	0000h	Set based on PMBus Address	54
D4h	POWER_GOOD_DELAY	Sets the delay between $V_{OUT} > PG$ threshold and asserting the PG pin.	R/W Word	L11	BA00h	1ms	55
DFh	ASCR_CONFIG	Configures ASCR control loop.	R/W Block	CUS	01500258h	Residual = 80 Gain = 600	55
E0h	SEQUENCE	Identifies the rail DDC ID to perform multi-rail sequencing.	R/W Word	BIT	0000h	Prequel and Sequel Disabled	56
E1h	TRACK_CONFIG	Configures the voltage tracking modes of the device.	READ Byte	BIT	00h	Tracking Disabled	56
E2h	DDC_GROUP	Sets rail DDC IDs to obey faults and margining spreading information.	R/W Block	BIT	00000000h	Broadcast Disabled	57
E4h	DEVICE_ID	Returns the 16-byte (character) device identifier string.	READ Block	ASC		Reads Device Version	57
E5h	MFR_IOUT_OC_FAULT_RESPONSE	Configures the I_{OUT} overcurrent fault response.	R/W Byte	BIT	80h	Disable and No Retry	58
E6h	MFR_IOUT_UC_FAULT_RESPONSE	Configures the I_{OUT} undercurrent fault response.	R/W Byte	BIT	80h	Disable and No Retry	58
E7h	IOUT_AVG_OC_FAULT_LIMIT	Sets the I_{OUT} average overcurrent fault threshold.	R/W Byte	L11	E280h	40A	59
E8h	IOUT_AVG_UC_FAULT_LIMIT	Sets the I_{OUT} average undercurrent fault threshold.	R/W Byte	L11	DC40h	-30A	59
E9h	SYNC_CONFIG	Configures the SYNC pin.	R/W Byte	BIT	00h	Pin-Strap	60
EAh	SNAPSHOT	Returns 32-byte read-back of parametric and status values.	READ Block	BIT			60
EBh	BLANK_PARAMS	Returns recently changed parameter values.	READ Block	BIT	FF...FFh		61
F3h	SNAPSHOT_CONTROL	Snapshot feature control command.	WRITE Byte	BIT			61
F4h	RESTORE_FACTORY	Restores device to the factory default values.	SEND Byte				61
F5h	VIN_OV_FAULT_LIMIT	Returns the V_{IN} overvoltage threshold.	R/W Word	L11	CA40h	4.5V	61
F6h	VIN_UV_FAULT_LIMIT	Returns the V_{IN} undervoltage threshold.	R/W Word	L11	C266h	2.4V	62
F7h	READ_VIN	Returns the V_{IN} voltage reading.	READ Word	L11			62
F8h	VIN_OV_FAULT_RESPONSE	Returns the V_{IN} overvoltage response.	R/W Byte	BIT	80h	Disable and No Retry	62
F9h	VIN_UV_FAULT_RESPONSE	Returns the V_{IN} undervoltage response.	R/W Byte	BIT	80h	Disable and No Retry	63

8. PMBus Data Formats

Linear-11 (L11)

The L11 data format uses 5-bit two's complement exponent (N) and 11-bit two's complement mantissa (Y) to represent real world decimal value (X).

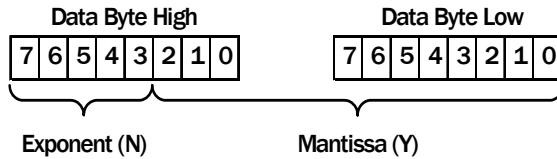

The relation between real world decimal value (X), N and Y is: $X = Y \cdot 2^N$

Linear-16 Unsigned (L16u)

The L16u data format uses a fixed exponent (hard-coded to $N = -13$) and a 16-bit unsigned integer mantissa (Y) to represent real world decimal value (X). Relation between real world decimal value (X), N and Y is: $X = Y \cdot 2^{-13}$

Linear-16 Signed (L16s)

The L16s data format uses a fixed exponent (hard-coded to $N = -13$) and a 16-bit two's complement mantissa (Y) to represent real world decimal value (X).

Relation between real world decimal value (X), N and Y is: $X = Y \cdot 2^{-13}$

Bit Field (BIT)

A description of the Bit Field format is provided in the [“PMBus Commands Description” on page 33](#).

Custom (CUS)

A description of the Custom data format is provided in the [“PMBus Commands Description” on page 33](#). A combination of Bit Field and integer are common type of Custom data format.

ASCII (ASC)

A variable length string of text characters that uses the ASCII data format.

9. PMBus Use Guidelines

PMBus is a powerful tool that allows the user to optimize circuit performance by configuring devices for their application. When configuring a device in a circuit, the device should be disabled whenever most settings are changed with PMBus commands. Some exceptions to this recommendation are OPERATION, ON_OFF_CONFIG, CLEAR_FAULTS, VOUT_COMMAND, VOUT_MARGIN_HIGH, VOUT_MARGIN_LOW, and ASCR_CONFIG. While the device is enabled any command can be read. Many commands do not take effect until after the device has been re-enabled, hence the recommendation that commands that change device settings are written while the device is disabled.

When sending the STORE_DEFAULT_ALL, STORE_USER_ALL, RESTORE_DEFAULT_ALL, and RESTORE_USER_ALL commands, it is recommended that no other commands are sent to the device for 100ms after sending STORE or RESTORE commands.

In addition, there should be a 2ms delay between repeated READ commands sent to the same device. When sending any other command, a 5ms delay is recommended between repeated commands sent to the same device. Commands not listed in the PMBus command summary (including EFh, DBh, E3h, and F1h) are not allowed for customer use, and are reserved for factory use only. Issuing reserved commands may result in unexpected operation.

9.1 Summary

All commands can be read at any time.

Always disable the device when writing commands that change device settings. Exceptions to this rule are commands intended to be written while the device is enabled, for example, VOUT_MARGIN_HIGH.

To be sure a change to a device setting has taken effect, write the STORE_USER_ALL command, then cycle input power and re-enable.

10. PMBus Commands Description

OPERATION (01h)

Definition: Sets Enable, Disable, and V_{OUT} margin settings. Data values of OPERATION that force margin high or low take effect only when the MGN pin is left open (that is, in the NOMINAL margin state).

Data Length in Bytes: 1

Data Format: BIT

Type: R/W

Default Value:

Units: N/A

Settings	Actions
04h	Immediate off (no sequencing)
44h	Soft off (with sequencing)
84h	On - Nominal
94h	On - Margin low
A4h	On - Margin high

ON_OFF_CONFIG (02h)

Definition: Configures the interpretation and coordination of the OPERATION command and the ENABLE pin (EN).

Data Length in Bytes: 1

Data Format: BIT

Type: R/W

Default Value: 17h (Device starts from ENABLE pin with immediate off)

Units: N/A

Settings	Actions
00h	Device starts any time power is present regardless of ENABLE pin or OPERATION command states.
16h	Device starts from ENABLE pin with soft off.
17h	Device starts from ENABLE pin with immediate off.
1Ah	Device starts from OPERATION command.

CLEAR_FAULTS (03h)

Definition: Clears all fault bits in all registers and releases the SALRT pin (if asserted) simultaneously. If a fault condition still exists, the bit will reassert immediately. This command will not restart a device if it has shut down, it will only clear the faults.

Data Length in Bytes: 0 Byte

Data Format: N/A

Type: Write only

Default Value: N/A

Units: N/A

Reference: N/A

STORE_USER_ALL (15h)

Definition: Stores all PMBus settings from the operating memory to the non-volatile USER store memory. To clear the USER store, perform a RESTORE_FACTORY then STORE_USER_ALL. To add to the USER store, perform a RESTORE_USER_ALL, write commands to be added, then STORE_USER_ALL. This command can be used during device operation, but the device will be unresponsive for 20ms while storing values.

Data Length in Bytes: 0

Data Format: N/A

Type: Write Only

Default Value: N/A

Units: N/A

RESTORE_USER_ALL (16h)

Definition: Restores all PMBus settings from the USER store memory to the operating memory. Command performed at power-up. Security level is changed to Level 1 following this command. This command can be used during device operation, but the device will be unresponsive for 20ms while storing values.

Data Length in Bytes: 0

Data Format: N/A

Type: Write Only

Default Value: N/A

Units: N/A

VOUT_MODE (20h)

Definition: Reports the V_{OUT} mode and provides the exponent used in calculating several V_{OUT} settings. Fixed with linear mode with default exponent (N) = -13

Data Length in Bytes: 1

Data Format: BIT

Type: Read Only

Default Value: 13h (Linear Mode, N = -13)

Units: N/A

VOUT_COMMAND (21h)

Definition: This command sets or reports the target output voltage. This command cannot set a value higher than either VOUT_MAX or 110% of the pin-strap V_{OUT} setting.

Data Length in Bytes: 2

Data Format: L16u

Type: R/W

Default Value: Pin-strap setting

Units: Volts

Range: 0V to VOUT_MAX

VOUT_CAL_OFFSET (23h)

Definition: The VOUT_CAL_OFFSET command is used to apply a fixed offset voltage to the output voltage command value. This command is typically used by the user to calibrate a device in the application circuit.

Data Length in Bytes: 2

Data Format: L16s

Type: R/W

Default Value: 0000h

Units: Volts

VOUT_MAX (24h)

Definition: The VOUT_MAX command sets an upper limit on the output voltage the unit can command regardless of any other commands or combinations. The intent of this command is to provide a safeguard against a user accidentally setting the output voltage to a possibly destructive level rather than to be the primary output overprotection. Default value can be changed via PMBus.

Data Length in Bytes: 2

Data Format: L16u

Type: R/W

Default Value: 1.10 x VOUT_COMMAND pin-strap setting

Units: Volts

Range: 0V to 4V

VOUT_MARGIN_HIGH (25h)

Definition: Sets the value of the V_{OUT} during a margin high. This VOUT_MARGIN_HIGH command loads the unit with the voltage to which the output is to be changed when the OPERATION command is set to “Margin High”.

Data Length in Bytes: 2

Data Format: L16u

Type: R/W Word

Default value: 1.05 x VOUT_COMMAND pin-strap setting

Units: V

Range: 0V to VOUT_MAX

VOUT_MARGIN_LOW (26h)

Definition: Sets the value of the V_{OUT} during a margin low. This VOUT_MARGIN_LOW command loads the unit with the voltage to which the output is to be changed when the OPERATION command is set to “Margin Low”.

Data Length in Bytes: 2

Data Format: L16u

Type: R/W

Default value: 0.95 x VOUT_COMMAND pin-strap setting

Units: V

Range: 0V to VOUT_MAX

VOUT_TRANSITION_RATE (27h)

Definition: This command sets the rate at which the output should change voltage when the device receives an OPERATION command (Margin High, Margin Low) that causes the output voltage to change. The maximum possible positive value of the two data bytes indicates that the device should make the transition as quickly as possible.

Data Length in Bytes: 2

Data Format: L11

Type: R/W

Default value: BA00h (1.0 V/ms)

Units: V/ms

Range: 0.1V/ms to 4V/ms

VOUT_DROOP (28h)

Definition: The VOUT_DROOP sets the effective load line (V/I slope) for the rail in which the device is used. It is the rate, in mV/A at which the output voltage decreases (or increases) with increasing (or decreasing) output current for use with Adaptive Voltage Positioning requirements and passive current sharing schemes.

Data Length in Bytes: 2

Data Format: L11

Type: R/W

Default value: 0000h (0mV/A)

Units: mV/A

Range: 0mV/A to 40mV/A

FREQUENCY_SWITCH (33h)

Definition: Sets the switching frequency of the device. Initial default value is defined by a pin strap and this value can be overridden by writing this command with PMBus. If an external SYNC is used, this value should be set as close as possible to the external clock value. The output must be disabled when writing this command.

Data Length in Bytes: 2

Data Format: L11

Type: R/W

Default Value: Pin-strap setting

Units: kHz

Range: 300kHz to 1066MHz

INTERLEAVE (37h)

Definition: Configures the phase offset of a device that is sharing a common SYNC clock with other devices. A value of 0 for the Number in Group field is interpreted as 16, to allow for phase spreading groups of up to 16 devices. The current share devices then automatically distribute their phase relative to the INTERLEAVE setting.

Data Length in Bytes: 2

Data Format: BIT

Type: R/W

Default Value:

Default Group Number: 0 (00h)

Default Number in Group: 16 (00h)

Default Position in Group: Four LSBs of SMBus address

Units: kHz

Bits	Purpose	Value	Description
15:12	Reserved	0	Reserved
11:8	Group Number	0 to 15	Not used
7:4	Number in Group	0 to 15	Sets the number of rails in the group A value of 0 is interpreted as 16
3:0	Position in Group	0 to 15	Sets position of the device's rail within the group

IOUT_CAL_GAIN (38h)

Definition: Sets the effective impedance across the current sense circuit for use in calculating output current at +25°C.

Data Length in Bytes: 2

Data Format: L11

Type: R/W

Default Value: B29Ah (0.65mΩ)

Units: mΩ

IOUT_CAL_OFFSET (39h)

Definition: Used to null out any offsets in the output current sensing circuit, and to compensate for delayed measurements of current ramp due to I_{SENSE} blanking time.

Data Length in Bytes: 2

Data Format: 11

Type: R/W

Default Value: 0000h (0A)

Units: A

VOUT_OV_FAULT_LIMIT (40h)

Definition: Sets the V_{OUT} overvoltage fault threshold.

Data Length in Bytes: 2

Data Format: L16u

Type: R/W

Default Value: 1.15 x VOUT_COMMAND pin-strap setting

Units: V

Range: 0V to VOUT_MAX

VOUT_OV_FAULT_RESPONSE (41h)

Definition: Configures the V_{OUT} overvoltage fault response. Note that the device cannot be set to ignore this fault mode.

Data Length in Bytes: 1

Data Format: BIT

Type: R/W

Default Value: 80h (Disable and no retry)

Units: N/A

Bit	Field Name	Value	Description
7:6	Reserved	10	
5:3	Retry Setting	000	No retry. The output remains disabled until the fault is cleared.
		001-110	Not used.
		111	Attempts to restart continuously, without checking if the fault is still present, until it is commanded OFF (by the CONTROL pin or OPERATION command), bias power is removed, or another fault condition causes the unit to shut down.
2:0	Retry Delay	000-111	Retry delay time = (Value + 1) * 35ms. Sets the time between retries in 35ms

VOUT_OV_WARNING_LIMIT (42h)

Definition: Sets the V_{OUT} overvoltage warning threshold. The Power-Good signal is pulled low when output voltage goes higher than this threshold.

Data Length in Bytes: 2

Data Format: L16u

Type: R/W

Default Value: 1.1xVOUT_COMMAND pin-strap setting

Units: V

Range: 0V to VOUT_MAX

VOUT_UV_WARNING_LIMIT (43h)

Definition: Sets the V_{OUT} undervoltage warning threshold. The Power-Good signal is pulled low when output voltage goes lower than this threshold.

Data Length in Bytes: 2

Data Format: L16u

Type: R/W

Default Value: 0.9 x VOUT_COMMAND pin-strap setting

Units: V

Range: 0V to VOUT_MAX

VOUT_UV_FAULT_LIMIT (44h)

Definition: Sets the V_{OUT} undervoltage fault threshold. This fault is masked during ramp or when disabled.

Data Length in Bytes: 2

Data Format: L16u

Type: R/W

Default Value: 0.85 x VOUT_COMMAND pin-strap setting

Units: V

Range: 0V to VOUT_MAX

VOUT_UV_FAULT_RESPONSE (45h)

Definition: Configures the V_{OUT} undervoltage fault response.

Data Length in Bytes: 1

Data Format: BIT

Type: R/W

Default Value: 80h (Disable, no retry)

Units: N/A

Bit	Field Name	Value	Description
7:6	Reserved	10	
5:3	Retry Setting	000	No retry. The output remains disabled until the fault is cleared.
		001-110	Not used.
		111	Attempts to restart continuously, without checking if the fault is still present, until it is commanded OFF (by the CONTROL pin or OPERATION command), bias power is removed, or another fault condition causes the unit to shut down.
2:0	Retry Delay	000-111	Retry delay time = (Value + 1) * 35ms. Sets the time between retries in 35ms

IOUT_OC_FAULT_LIMIT (46h)

Definition: Sets the I_{OUT} peak overcurrent fault threshold. This limit is applied to current measurement samples taken after the Current Sense Blanking Time has expired. A fault occurs after this limit is exceeded. The recommended peak OCP limit is determined by [\(EQ. 2\)](#).

$$(EQ. 2) \quad IOUT_OC_FAULT_LIMIT = (IOUT_AVG_OC_FAULT_LIMIT + 0.5 \cdot IRIPPLE_{P_P}) \cdot 130\%$$

This feature shares the OC fault bit operation (in STATUS_IOUT) and OC fault response with the IOUT_AVG_OC_FAULT_LIMIT.

Data Length in Bytes: 2

Data Format: L11

Type: R/W

Default Value: E341h (52.062A)

Units: A

Range: -100A to 100A

IOUT_UC_FAULT_LIMIT (4Bh)

Definition: Sets the I_{OUT} peak undercurrent fault threshold. The device has a default peak UCP limit. Its value can be overridden by writing to the IOUT_UC_FAULT_LIMIT register.

Data Length in Bytes: 2

Data Format: L11

Type: R/W

Default Value: E58Fh (-39.062A)

Units: A

Range: -100A to 100A

OT_FAULT_LIMIT (4Fh)

Definition: The OT_FAULT_LIMIT command sets the temperature at which the device should indicate an over-temperature fault. Note that the temperature must drop below OT_WARN_LIMIT to clear this fault.

Data Length in Bytes: 2

Data Format: L11

Type: R/W

Default Value: EB98h (+115°C)

Units: Celsius

Range: 0°C to +175°C

OT_FAULT_RESPONSE (50h)

Definition: The OT_FAULT_RESPONSE command instructs the device on what action to take in response to an over-temperature fault.

Data Length in Bytes: 1

Data Format: BIT

Type: R/W

Fault Value: 80h (Disable and no retry)

Units: N/A

Bit	Field Name	Value	Description
7:6	Reserved	10	
5:3	Retry Setting	000	No retry. The output remains disabled until the fault is cleared.
		001-110	Not used.
		111	Attempts to restart continuously, without checking if the fault is still present, until it is commanded OFF (by the CONTROL pin or OPERATION command), bias power is removed, or another fault condition causes the unit to shut down.
2:0	Retry Delay	000-111	Retry delay time = (Value + 1) * 35ms. Sets the time between retries in 35ms

OT_WARN_LIMIT (51h)

Definition: The OT_WARN_LIMIT command sets the temperature at which the device should indicate an over-temperature warning alarm. In response to the OT_WARN_LIMIT being exceeded, the device sets the TEMPERATURE bit in STATUS_WORD, sets the OT_WARNING bit in STATUS_TEMPERATURE, and notifies the host.

Data Length in Bytes: 2

Data Format: Linear-11

Type: R/W

Default Value: EB48h (+105°C)

Units: Celsius

Range: 0°C to +175°C

UT_WARN_LIMIT (52h)

Definition: The UT_WARN_LIMIT command set the temperature at which the device should indicate an under-temperature Warning alarm. In response to the UT_WARN_LIMIT being exceeded, the device sets the TEMPERATURE bit in STATUS_WORD, sets the UT_WARNING bit in STATUS_TEMPERATURE, and notifies the host.

Data Length in Bytes: 2

Data Format: L11

Type: R/W

Default Value: E580h (-40°C)

Units: Celsius

Range: -55°C to +25°C

UT_FAULT_LIMIT (53h)

Definition: Sets the temperature, in degrees Celsius, of the unit where it should indicate an under-temperature fault. Note that the temperature must rise above UT_WARN_LIMIT to clear this fault.

Data Length in Bytes: 2

Data Format: L11

Type: R/W

Default Value: E4E0h (-50°C)

Units: Celsius

Range: -55°C to +25°C

UT_FAULT_RESPONSE (54h)

Definition: Configures the under-temperature fault response as defined by the following table. The delay time is the time between restart attempts.

Data Length in Bytes: 1

Data Format: BIT

Type: R/W

Default Value: 80h (Disable, no retry)

Units: N/A

Bit	Field Name	Value	Description
7:6	Reserved	10	
5:3	Retry Setting	000	No retry. The output remains disabled until the fault is cleared.
		001-110	Not used.
		111	Attempts to restart continuously, without checking if the fault is still present, until it is commanded OFF (by the CONTROL pin or OPERATION command), bias power is removed, or another fault condition causes the unit to shut down.
2:0	Retry Delay	000-111	Retry delay time = (Value + 1) * 35ms. Sets the time between retries in 35ms

VDRV_OV_FAULT_LIMIT (55h)

Definition: Sets the VDRV overvoltage fault threshold.

Data Length in Bytes: 2

Data Format: L11

Type: Read Only

Default Value: CB00h (6V)

Units: V

Range: 0V to 6V

VDRV_OV_FAULT_RESPONSE (56h)

Definition: Reads the VDRV and VDD OV fault response.

Data Length in Bytes: 1

Data Format: BIT

Type: READ ONLY

Default Value: 80h (Disable and no retry)

Units: N/A

VDRV_OV_WARN_LIMIT (57h)

Definition: Sets the VDRV overvoltage warning threshold as defined by the table below. In response to the OV_WARN_LIMIT being exceeded, the device sets the NONE OF THE ABOVE and INPUT bits in STATUS_WORD, sets the VDRV_OV_WARNING bit in STATUS_VDRV, and notifies the host.

Data Length in Bytes: 2

Data Format: L11

Type: Read Only

Protectable: Yes

Default Value: CAC0h (5.5V)

Units: V

Range: 0V to 6V

VDRV_UV_WARN_LIMIT (58h)

Definition: Sets the VDRV undervoltage warning threshold. If a VDRV_UV_FAULT occurs, the input voltage must rise above VDRV_UV_WARN_LIMIT to clear the fault, which provides hysteresis to the fault threshold. In response to the UV_WARN_LIMIT being exceeded, the device sets the NONE OF THE ABOVE and VDRV bits in STATUS_WORD, sets the VDRV_UV_WARNING bit in STATUS_VDRV, and notifies the host.

Data Length in Bytes: 2

Data Format: Linear-11

Type: Read Only

Default Value: CA40h (4.5V)

Units: V

Range: 0V to 6V

VDRV_UV_FAULT_LIMIT (59h)

Definition: Sets the VDRV undervoltage fault threshold.

Data Length in Bytes: 2

Data Format: L11

Type: Read Only

Default Value: CA00h (4V)

Units: V

Range: 0V to 6V

VDRV_UV_FAULT_RESPONSE (5Ah)

Definition: Reads the VDRV and VDD UV fault response.

Data Length in Bytes: 1

Data Format: BIT

Type: READ ONLY

Default Value: 80h (Disable and no retry)

Units: N/A

POWER_GOOD_ON (5Eh)

Definition: Sets the voltage threshold for Power-Good indication. Power-Good asserts when the output voltage exceeds POWER_GOOD_ON and de-asserts when the output voltage is less than VOUT_UV_FAULT_LIMIT.

Data Length in Bytes: 2

Data Format: L16u

Type: R/W

Default Value: 0.9 x VOUT_COMMAND pin-strap setting

Units: V

TON_DELAY (60h)

Definition: Sets the delay time from when the device is enabled to the start of V_{OUT} rise.

Data Length in Bytes: 2

Data Format: L11

Type: R/W

Default Value: 5

Units: ms

Range: 0 to 255ms

TON_RISE (61h)

Definition: Sets the rise time of V_{OUT} after ENABLE and TON_DELAY.

Data Length in Bytes: 2

Data Format: L11

Type: R/W

Default Value: 5

Units: ms

Range: 0 to 200ms

TOFF_DELAY (64h)

Definition: Sets the delay time from DISABLE to start of V_{OUT} fall.

Data Length in Bytes: 2

Data Format: L11

Type: R/W

Default Value: 5

Units: ms

Range: 0 to 255ms

TOFF_FALL (65h)

Definition: Sets the fall time for V_{OUT} after DISABLE and TOFF_DELAY.

Data Length in Bytes: 2

Data Format: L11

Type: R/W

Default Value: 5

Units: ms

Range: 0 to 200ms

STATUS_BYTE (78h)

Definition: Returns one byte of information with a summary of the most critical faults.

Data Length in Bytes: 1

Data Format: BIT

Type: Read Only

Default Value: 00h

Units: N/A

Bit Number	Status Bit Name	Meaning
7	BUSY	A fault was declared because the device was busy and unable to respond.
6	OFF	This bit is asserted if the unit is not providing power to the output, regardless of the reason, including simply not being enabled.
5	VOUT_OV_FAULT	An output overvoltage fault has occurred.
4	IOUT_OC_FAULT	An output overcurrent fault has occurred.
3	VDRV_UV_FAULT	A VDRV undervoltage fault has occurred.
2	TEMPERATURE	A temperature fault or warning has occurred.
1	CML	A communications, memory or logic fault has occurred.
0	NONE OF THE ABOVE	A fault or warning not listed in Bits 7:1 has occurred.

STATUS_WORD (79h)

Definition: Returns two bytes of information with a summary of the unit's fault condition. Based on the information in these bytes, the host can get more information by reading the appropriate status registers. The low byte of the STATUS_WORD is the same register as the STATUS_BYTE (78h) command.

Data Length in Bytes: 2

Data Format: BIT

Type: Read Only

Default Value: 0000h

Units: N/A

Bit Number	Status Bit Name	Meaning
15	VOUT	An output voltage fault or warning has occurred.
14	IOUT/POUT	An output current or output power fault or warning has occurred.
13	VDRV	A VDRV fault or warning has occurred.
12	INPUT	An input voltage fault or warning has occurred.
11	POWER_GOOD#	The POWER_GOOD signal, if present, is negated.
10	FANS	A fan or airflow fault or warning has occurred.
9	OTHER	A bit in STATUS_OTHER is set.
8	UNKNOWN	A fault type not given in bits 15:1 of the STATUS_WORD has been detected.
7	BUSY	A fault was declared because the device was busy and unable to respond.
6	OFF	This bit is asserted if the unit is not providing power to the output, regardless of the reason, including simply not being enabled.
5	VOUT_OV_FAULT	An output overvoltage fault has occurred.
4	IOUT_OC_FAULT	An output overcurrent fault has occurred.
3	VDRV_UV_FAULT	A VDRV undervoltage fault has occurred.
2	TEMPERATURE	A temperature fault or warning has occurred.
1	CML	A communications, memory or logic fault has occurred.
0	NONE OF THE ABOVE	A fault or warning not listed in Bits 7:1 has occurred.

STATUS_VOUT (7Ah)**Definition:** Returns one data byte with the status of the output voltage.**Data Length in Bytes:** 1**Data Format:** BIT**Type:** Read Only**Default Value:** 00h**Units:** N/A

Bit Number	Status Bit Name	Meaning
7	VOUT_OV_FAULT	Indicates an output overvoltage fault.
6	VOUT_OV_WARNING	Indicates an output overvoltage warning.
5	VOUT_UV_WARNING	Indicates an output undervoltage warning.
4	VOUT_UV_FAULT	Indicates an output undervoltage fault.
3:0	N/A	These bits are not used.

STATUS_IOUT (7Bh)**Definition:** Returns one data byte with the status of the output current.**Data Length in Bytes:** 1**Data Format:** BIT**Type:** Read Only**Default Value:** 00h**Units:** N/A

Bit Number	Status Bit Name	Meaning
7	IOUT_OC_FAULT	An output overcurrent fault has occurred.
6	IOUT_OC_LV_FAULT	An output overcurrent and low voltage fault has occurred.
5	IOUT_OC_WARNING	An output overcurrent warning has occurred.
4	IOUT_UC_FAULT	An output undercurrent fault has occurred.
3:0	N/A	These bits are not used.

STATUS_VDRV (7Ch)**Definition:** Returns input voltage and input current status information.**Data Length in Bytes:** 1**Data Format:** BIT**Type:** Read Only**Default Value:** 00h**Units:** N/A

Bit Number	Status Bit Name	Meaning
7	VDRV_OV_FAULT	A VDRV overvoltage fault has occurred.
6	VDRV_OV_WARNING	A VDRV overvoltage warning has occurred.
5	VDRV_UV_WARNING	A VDRV undervoltage warning has occurred.
4	VDRV_UV_FAULT	A VDRV undervoltage fault has occurred.
3:0	N/A	These bits are not used.

STATUS_TEMP (7Dh)**Definition:** Returns one byte of information with a summary of any temperature related faults or warnings.**Data Length in Bytes:** 1**Data Format:** BIT**Type:** Read Only**Default Value:** 00h**Units:** N/A

Bit Number	Status Bit Name	Meaning
7	OT_FAULT	An over-temperature fault has occurred.
6	OT_WARNING	An over-temperature warning has occurred.
5	UT_WARNING	An under-temperature warning has occurred.
4	UT_FAULT	An under-temperature fault has occurred.
3:0	N/A	These bits are not used.

STATUS_CML (7Eh)

Definition: Returns one byte of information with a summary of any communications, logic, and/or memory errors.

Data Length in Bytes: 1

Data Format: BIT

Type: Read Only

Default Value: 00h

Units: N/A

Bit Number	Meaning
7	Invalid or unsupported PMBus command was received.
6	The PMBus command was sent with invalid or unsupported data.
5	A packet error was detected in the PMBus command.
4:2	Not Used.
1	A PMBus command tried to write to a read only or protected command, or a communication fault other than the ones listed in this table has occurred.
0	Not Used.

STATUS_INPUT (80h)

Definition: Returns one byte of information providing the status of the device's voltage monitoring and clock synchronization faults.

Data Length in Bytes: 1

Data Format: BIT

Type: Read Only

Default value: 00h

Units: N/A

Bit Number	Field Name	Meaning
7:6	Reserved	
5	VIN UV Warning	The voltage on the VMON pin has dropped below the level set by VIN_UV_FAULT_LIMIT.
4	VIN OV Warning	The voltage on the VMON pin has risen above the level set by VIN_OV_FAULT_LIMIT.
3	External Switching Period Fault	Loss of external clock synchronization has occurred.
2	Reserved	
1	VIN UV Fault	The voltage on the VMON pin has dropped below the level set by VIN_UV_FAULT_LIMIT.
0	VIN OV Fault	The voltage on the VMON pin has risen above the level set by VIN_OV_FAULT_LIMIT.

READ_VDRV (88h)

Definition: Returns the VDRV voltage reading.

Data Length in Bytes: 2

Data Format: L11

Type: Read Only

Units: V

READ_VOUT (8Bh)

Definition: Returns the output voltage reading.

Data Length in Bytes: 2

Data Format: L16u

Type: Read Only

Units: V

READ_IOUT (8Ch)

Definition: Returns the output current reading.

Data Length in Bytes: 2

Data Format: L11

Type: Read Only

Default Value: N/A

Units: A

READ_TEMPERATURE_1 (8Dh)

Definition: Returns the controller junction temperature reading from internal temperature sensor.

Data Length in Bytes: 2

Data Format: L11

Type: Read Only

Units: °C

READ_TEMPERATURE_2 (8Eh)

Definition: Returns the temperature reading from the external temperature device connected to the XTEMP pins.

Data Length in Bytes: 2

Data Format: L11

Type: Read Only

Units: °C

READ_DUTY_CYCLE (94h)

Definition: Reports the actual duty cycle of the converter during the enable state.

Data Length in Bytes: 2

Data Format: L11

Type: Read Only

Units: %

READ_FREQUENCY (95h)

Definition: Reports the actual switching frequency of the converter during the enable state.

Data Length in Bytes: 2

Data Format: L11

Type: Read Only

Units: kHz

MFR_ID (99h)

Definition: Sets a user defined manufacturer identification. The sum total of characters in MFR_ID, MFR_MODEL, MFR_REVISION, MFR_LOCATION, MFR_DATE, MFR_SERIAL and USER_DATA_00 plus one byte per command cannot exceed 128 characters. This limitation includes multiple writes of this command before a STORE command. To clear multiple writes, perform a RESTORE, write this command, then perform a STORE/RESTORE.

Data Length in Bytes: User defined

Data Format: ASCII

Type: Block R/W

Default Value: null

Units: N/A

MFR_MODEL (9Ah)

Definition: Sets a user defined model. The sum total of characters in MFR_ID, MFR_MODEL, MFR_REVISION, MFR_LOCATION, MFR_DATE, MFR_SERIAL and USER_DATA_00 plus one byte per command cannot exceed 128 characters. This limitation includes multiple writes of this command before a STORE command. To clear multiple writes, perform a RESTORE, write this command, then perform a STORE/RESTORE.

Data Length in Bytes: User defined

Data Format: ASC

Type: Block R/W

Default Value: null

Units: N/A

MFR_REVISION (9Bh)

Definition: Sets a user defined revision. The sum total of characters in MFR_ID, MFR_MODEL, MFR_REVISION, MFR_LOCATION, MFR_DATE, MFR_SERIAL and USER_DATA_00 plus one byte per command cannot exceed 128 characters. This limitation includes multiple writes of this command before a STORE command. To clear multiple writes, perform a RESTORE, write this command, then perform a STORE/RESTORE.

Data Length in Bytes: User defined

Data Format: ASC

Type: Block R/W

Default Value: null

Units: N/A

MFR_LOCATION (9Ch)

Definition: Sets a user defined location identifier. The sum total of characters in MFR_ID, MFR_MODEL, MFR_REVISION, MFR_LOCATION, MFR_DATE, MFR_SERIAL and USER_DATA_00 plus one byte per command cannot exceed 128 characters. This limitation includes multiple writes of this command before a STORE command. To clear multiple writes, perform a RESTORE, write this command, then perform a STORE/RESTORE.

Data Length in Bytes: User defined

Data Format: ASC

Type: Block R/W

Default Value: null

Units: N/A

MFR_DATE (9Dh)

Definition: Sets a user defined date. The sum total of characters in MFR_ID, MFR_MODEL, MFR_REVISION, MFR_LOCATION, MFR_DATE, MFR_SERIAL and USER_DATA_00 plus one byte per command cannot exceed 128 characters. This limitation includes multiple writes of this command before a STORE command. To clear multiple writes, perform a RESTORE, write this command, then perform a STORE/RESTORE.

Data Length in Bytes: User defined

Data Format: ASC

Type: Block R/W

Default Value: null

Units: N/A

Reference: N/A

MFR_SERIAL (9Eh)

Definition: Sets a user defined serialized identifier. The sum total of characters in MFR_ID, MFR_MODEL, MFR_REVISION, MFR_LOCATION, MFR_DATE, MFR_SERIAL and USER_DATA_00 plus one byte per command cannot exceed 128 characters. This limitation includes multiple writes of this command before a STORE command. To clear multiple writes, perform a RESTORE, write this command, then perform a STORE/RESTORE.

Data Length in Bytes: User defined

Data Format: ASC

Type: Block R/W

Default Value: null

Units: N/A

LEGACY_FAULT_GROUP (A8h)

Definition: Sets rail IDs of legacy devices for fault spreading.

Data Format: BIT

Type: Block R/W

Default Value: 00000000h

Units: N/A

IC_DEVICE_ID (ADh)**Definition:** Reports device identification information**Data Length in Bytes:** 4**Data Format:** CUS**Type:** Block Read**Default Value:** 49B01500h (Renesas ZL9024M)**Units:** N/A**USER_DATA_00 (B0h)****Definition:** Sets a user defined data. The sum total of characters in MFR_ID, MFR_MODEL, MFR_REVISION, MFR_LOCATION, MFR_DATE, MFR_SERIAL and USER_DATA_00 plus one byte per command cannot exceed 128 characters. This limitation includes multiple writes of this command before a STORE command. To clear multiple writes, perform a RESTORE, write this command, then perform a STORE/RESTORE.**Data Length in Bytes:** User defined**Data Format:** ASCII**Type:** Block R/W**Default Value:** null**Units:** N/A**ISENSE_CONFIG (D0h)****Definition:** Configures current sense circuitry.**Data Length in Bytes:** 1**Data Format:** BIT**Type:** R/W Byte**Default Value:** 25h**Units:** N/A

Bit	Field Name	Value	Setting	Description
7:4	Reserved	00100101		
3:2	Current Sense Blanking Time	00	192ns	Sets the blanking time current sense blanking time.
		01	256ns	
		10	412ns	
		11	640ns	
1:0	Current Sense Range	00	Low Range	±25mV
		01	Mid Range	±35mV
		10	High Range	±50mV
		11	Not Used	

USER_CONFIG (D1h)

Definition: Configures several user-level features. This command overrides the CONFIG pin settings.

Data Length in Bytes: 1

Data Format: BIT

Type: R/W

Default Value: 00h

Units: N/A

Bit	Field Name	Value	Setting	Description
7:5	Reserved	0		Reserved.
4:3	Ramp-Up and Ramp-Down Minimum Duty Cycle	00	0.39%	Sets the minimum duty-cycle during start-up and shutdown ramp. Must be enabled with Bit 10.
		01	0.78%	
		10	1.17%	
		11	1.56%	
2	Minimum Duty Cycle Control	0	Disable	Control for minimum duty cycle.
		1	Enable	
1	Power-Good Pin Configuration	0	Open Drain	0 = PG is open drain output. 1 = PG is push-pull output.
		1	Push-Pull	
0	XTEMP Enable	0	Disable	Enables external temperature monitoring.
		1	Enable	

DDC_CONFIG (D3h)

Definition: Configures DDC addressing and current sharing.

Data Length in Bytes: 2

Data Format: BIT

Type: R/W

Default Value: 0000h

Units: N/A

Bit	Field Name	Value	Setting	Description
15:13	Phase ID	0 to 7	0	Sets the output's phase position within the group.
12:8	Rail ID	0 to 31 (00 to 1Fh)	0	Identifies the device as part of a current sharing rail (shared output).
7:3	Reserved	00	Reserved	Reserved.
2:0	Devices In Rail	0 to 7	0	Identifies the number of devices on the same rail (+1).

POWER_GOOD_DELAY (D4h)

Definition: Sets the delay applied between the output exceeding the PG threshold (POWER_GOOD_ON) and asserting the PG pin. The delay time can range from 0ms up to 5000ms, in steps of 125ns. A 1ms minimum configured value is recommended to apply proper de-bounce to this signal.

Data Length in Bytes: 2

Data Format: L11

Type: R/W

Default Value: 1ms

Units: ms

Range: 0 to 5000ms

ASCR_CONFIG (DFh)

Definition: Allows user configuration of ASCR settings.

Data Length in Bytes: 4

Data Format: CUS

Type: R/W

Default Value: 01500258h

Bit	Purpose	Data Format	Value	Description
31:25	Unused		0000000h	Unused
24	ASCR Enable	BIT	1	Enable
			0	Disable
23:16	ASCR Residual Setting	Integer		
15:0	ASCR Gain Setting	Integer		

SEQUENCE (E0h)

Definition: Identifies the Rail DDC ID of the prequel and sequel rails when performing multi-rail sequencing. The device will enable its output when its EN or OPERATION enable states, as defined by ON_OFF_CONFIG, is set and the prequel device has issued a Power-Good event on the DDC bus. The device will disable its output (using the programmed delay values) when the sequel device has issued a Power-Down event on the DDC bus.

The data field is a two-byte value. The most-significant byte contains the 5-bit Rail DDC ID of the prequel device. The least-significant byte contains the 5-bit Rail DDC ID of the sequel device. The most significant bit of each byte contains the enable of the prequel or sequel mode. This command overrides the corresponding sequence configuration set by the CONFIG pin settings.

Data Length in Bytes: 2

Data Format: BIT

Type: R/W

Default Value: 0000h (Prequel and Sequel disabled)

Bit	Field Name	Value	Setting	Description
15	Prequel Enable	0	Disable	Disable, no prequel preceding this rail.
		1	Enable	Enable, prequel to this rail is defined by Bits 12:8.
14:13	Reserved	0	Reserved	Reserved.
12:8	Prequel Rail DDC ID	0-31	DDC ID	Set to the DDC ID of the prequel rail.
7	Sequel Enable	0	Disable	Disable, no sequel following this rail.
		1	Enable	Enable, sequel to this rail is defined by Bits 4:0.
6:5	Reserved	0	Reserved	Reserved.
4:0	Sequel Rail DDC ID	0-31	DDC ID	Set to the DDC ID of the sequel rail.

TRACK_CONFIG (E1h)

Definition: Configures the voltage tracking modes of the device. Tracking is not supported when the ZL9024M is in current sharing configuration.

Data Length in Bytes: 1

Data Format: BIT

Type: Read Only

Default Value: 00h (Tracking Disabled)

DDC_GROUP (E2h)

Definition: Configures fault spreading group ID and enable, broadcast OPERATION group ID and enable, and broadcast VOUT_COMMAND group ID and enable.

Data Length in Bytes: 4

Data Format: BIT

Type: R/W

Default Value: 00000000h (Ignore BROADCAST VOUT_COMMAND and OPERATION, Sequence shutdown on POWER_FAIL event)

Bits	Purpose	Value	Description
31:22	Reserved	0	Reserved
21	BROADCAST_VOUT_COMMAND Response	1	Responds to BROADCAST_VOUT_COMMAND with same Group ID.
		0	Ignores BROADCAST_VOUT_COMMAND.
20:16	BROADCAST_VOUT_COMMAND Group ID	0-31d	Group ID sent as data for broadcast BROADCAST_VOUT_COMMAND events.
15:14	Reserved	0	Reserved.
13	BROADCAST_OPERATION Response	1	Responds to BROADCAST_OPERATION with same Group ID.
		0	Ignores BROADCAST_OPERATION.
12:8	BROADCAST_OPERATION Group ID	0-31d	Group ID sent as data for broadcast BROADCAST_OPERATION events.
7:6	Reserved	0	Reserved.
5	POWER_FAIL Response	1	Responds to POWER_FAIL events with same Group ID by shutting down immediately.
		0	Responds to POWER_FAIL events with same Group ID with sequenced shutdown.
4:0	POWER_FAIL group ID	0-31d	Group ID sent as data for broadcast POWER_FAIL events.

DEVICE_ID (E4h)

Definition: Returns the 16-byte (character) device identifier string.

Data Length in Bytes: 16

Data Format: ASCII

Type: Block Read

Default Value: Part number/Die revision/Firmware revision

MFR_IOUT_OC_FAULT_RESPONSE (E5h)

Definition: Configures the I_{OUT} overcurrent fault response as defined by the following table. The command format is the same as the PMBus standard fault responses except that it sets the overcurrent status bit in STATUS_IOUT.

Data Length in Bytes: 1

Data Format: BIT

Type: R/W

Default Value: 80h (Disable, and no retry)

Units: N/A

Bit	Field Name	Value	Description
7:6	Reserved	10	
5:3	Retry Setting	000	No retry. The output remains disabled until the fault is cleared.
		001-110	Not used.
		111	Attempts to restart continuously, without checking if the fault is still present, until it is commanded OFF (by the CONTROL pin or OPERATION command), bias power is removed, or another fault condition causes the unit to shut down.
2:0	Retry Delay	000-111	Retry delay time = (Value + 1) * 35ms. Sets the time between retries in 35ms increments. Range is 35ms to 280ms.

MFR_IOUT_UC_FAULT_RESPONSE (E6h)

Definition: Configures the I_{OUT} undercurrent fault response as defined by the following table. The command format is the same as the PMBus standard fault responses except that it sets the undercurrent status bit in STATUS_IOUT.

Data Length in Bytes: 1

Data Format: BIT

Type: R/W

Default Value: 80h (Disable and no retry)

Units: N/A

Bit	Field Name	Value	Description
7:6	Reserved	10	
5:3	Retry Setting	000	No retry. The output remains disabled until the fault is cleared.
		001-110	Not used.
		111	Attempts to restart continuously, without checking if the fault is still present, until it is commanded OFF (by the CONTROL pin or OPERATION command), bias power is removed, or another fault condition causes the unit to shut down.
2:0	Retry Delay	000-111	Retry delay time = (Value + 1) * 35ms. Sets the time between retries in 35ms increments. Range is 35ms to 280ms.

IOUT_AVG_OC_FAULT_LIMIT (E7h)

Definition: Sets the I_{OUT} average overcurrent fault threshold. For down-slope sensing, this corresponds to the average of all the current samples taken during the (1-D) time interval, excluding the current sense blanking time (which occurs at the beginning of the 1-D interval). For up-slope sensing, this corresponds to the average of all the current samples taken during the D time interval, excluding the current sense blanking time (which occurs at the beginning of the D interval). This feature shares the OC fault bit operation (in STATUS_IOUT) and OC fault response with IOUT_OC_FAULT_LIMIT.

Paged or Global: Paged

Data Length in Bytes: 2

Data Format: L11

Type: R/W

Protectable: Yes

Default Value: E280h

Units: A

Equation: $IOUT_AVG_OC_FAULT_LIMIT = Y \times 2N$

Range: -100A to 100A

IOUT_AVG_UC_FAULT_LIMIT (E8h)

Definition: Sets the I_{OUT} average undercurrent fault threshold. For down-slope sensing, this corresponds to the average of all the current samples taken during the (1-D) time interval, excluding the current sense blanking time (which occurs at the beginning of the 1-D interval). For up-slope sensing, this corresponds to the average of all the current samples taken during the D time interval, excluding the current sense blanking time (which occurs at the beginning of the D interval). This feature shares the UC fault bit operation (in STATUS_IOUT) and UC fault response with IOUT_UC_FAULT_LIMIT.

Paged or Global: Paged

Data Length in Bytes: 2

Data Format: L11

Type: R/W

Protectable: Yes

Default Value: DC40h

Units: A

Equation: $IOUT_AVG_UC_FAULT_LIMIT = Y \times 2N$

Range: -100A to 100A

SYNC_CONFIG (E9h)

Definition: Sets options for SYNC output configurations.

Data Length in Bytes: 1

Data Format: BIT

Type: R/W

Default Value: 00h

Settings	Actions
00h	Use Internal clock. Clock frequency is set by pin strap or PMBus command.
02h	Use internal clock and output internal clock.
04h	Use external clock.

SNAPSHOT (EAh)

Definition: A 32-byte read-back of parametric and status values. It allows monitoring and status data to be stored to flash either during a fault condition or via a system-defined time using the SNAPSHOT_CONTROL command. In case of a fault, last updated values are stored to the flash memory. Use SNAPSHOT_CONTROL command to read stored values.

Data Length in Bytes: 32

Data Format: Bit field

Type: Block Read

Byte Number	Value	PMBus Command	Format
31:22	NVM Status Byte	Reserved	00h
21	Input Status Byte	STATUS_INPUT (80h)	Byte
20	CML Status Byte	STATUS_CML (7Eh)	Byte
19	Temperature Status Byte	STATUS_TEMPERATURE (7Dh)	Byte
18	VDRV Status Byte	STATUS_VDRV (7Ch)	Byte
17	I _{OUT} Status Byte	STATUS_IOUT (7Bh)	Byte
16	V _{OUT} Status Byte	STATUS_VOUT (7Ah)	Byte
15:14	Switching Frequency	READ_FREQUENCY (95h)	L11
13:12	External Temperature	READ_TEMPERATURE_2 (8Eh)	L11
11:10	Internal Temperature	READ_TEMPERATURE_1 (8Dh)	L11
9:8	Duty Cycle	READ_DUTY_CYCLE (94h)	L11
7:6	Peak Current	N/A	L11
5:4	Load Current	READ_IOUT (8Ch)	L11
3:2	V _{OUT}	READ_VOUT (8Bh)	L16u
1:0	V _{DRV}	READ_VDRV (88h)	L11

BLANK_PARAMS (EBh)

Definition: Returns a 16-byte string indicating which parameter values were either retrieved by the last RESTORE operation or have been written since that time. Reading BLANK_PARAMS immediately after a restore operation allows the user to determine which parameters are stored in that store. A 1 indicates the parameter is not present in the store and has not been written since the RESTORE operation.

Data Length in Bytes: 16

Data Format: BIT

Type: Block Read

Default Value: FF...FFh

SNAPSHOT_CONTROL (F3h)

Definition: Using SNAPSHOT_CONTROL command stored parametric and status values in SNAPSHOT command can be moved from flash to RAM for a read, store latest parametric and status values from RAM to flash, or erase parametric and status values store in the flash. When parametric and status values is updated to the snapshot, it overwrites stored parametric and status values.

Data Length in Bytes: 1

Data Format: Bit field

Type: R/W

Value	Description
01h	Move parametric and status values from Flash to the RAM.
02h	Move latest parametric and status values from RAM to the Flash.
03h	Erase parametric and status values stored in SNAPSHOT.

RESTORE_FACTORY (F4h)

Definition: Restores the device to the hard-coded factory default values and pin-strap definitions. The device retains the DEFAULT and USER stores for restoring. Security level is changed to Level 1 following this command.

Data Length in Bytes: 0

Data Format: N/A

Type: Write Only

Default Value: N/A

Units: N/A

VIN_OV_FAULT_LIMIT (F5h)

Definition: Reads the VIN OV fault threshold.

Data Length in Bytes: 2

Data Format: L11

Type: R/W

Default Value: 4.5V

Units: V

Range: 0V to 5V

VIN_UV_FAULT_LIMIT (F6h)**Definition:** Reads the VIN UV fault threshold**Data Length in Bytes:** 2**Data Format:** L11**Type:** R/W**Default Value:** 2.4V**Units:** V**Range:** 0V to 5V**READ_VIN (F7h)****Definition:** Reads the VDRV voltage.**Data Length in Bytes:** 2**Data Format:** L11**Type:** Read Only**Default Value:** N/A**Units:** V**Range:** 0V to 4.5V**VIN_OV_FAULT_RESPONSE (F8h)****Definition:** Configures the V_{IN} overvoltage fault response as defined by the following table. The delay time is the time between restart attempts.**Data Length in Bytes:** 1**Data Format:** BIT**Type:** R/W**Default Value:** 80h (Disable and no retry)**Units:** N/A

Bit	Field Name	Value	Description
7:6	Reserved	10	
5:3	Retry Setting	000	No retry. The output remains disabled until the fault is cleared.
		001-110	Not used.
		111	Attempts to restart continuously, without checking if the fault is still present, until it is commanded OFF (by the CONTROL pin or OPERATION command), bias power is removed, or another fault condition causes the unit to shut down.
2:0	Retry Delay	000-111	Retry delay time = (Value + 1) * 35ms. Sets the time between retries in 35ms increments. Range is 35ms to 280ms.

VIN_UV_FAULT_RESPONSE (F9h)

Definition: Configures the V_{IN} undervoltage fault response as defined by the following table. The delay time is the time between restart attempts.

Data Length in Bytes: 1

Data Format: BIT

Type: R/W

Default Value: 80h (Disable and no retry)

Units: N/A

Bit	Field Name	Value	Description
7:6	Reserved	10	
5:3	Retry Setting	000	No retry. The output remains disabled until the fault is cleared.
		001-110	Not used.
		111	Attempts to restart continuously, without checking if the fault is still present, until it is commanded OFF (by the CONTROL pin or OPERATION command), bias power is removed, or another fault condition causes the unit to shut down.
2:0	Retry Delay	000-111	Retry delay time = (Value + 1) * 35ms. Sets the time between retries in 35ms increments. Range is 35ms to 280ms.

11. Firmware Revision History

Firmware Revision Code	Change Description	Note
ZL9024M-0-G0100	Initial Release	

12. Package Outline Drawing

For the most recent package outline drawing, see [Y40.17x19](#).

Y40.17x19
 40 I/O 17.0mm x 19.0mm x 3.55mm HDA MODULE
 Rev 3, 4/17

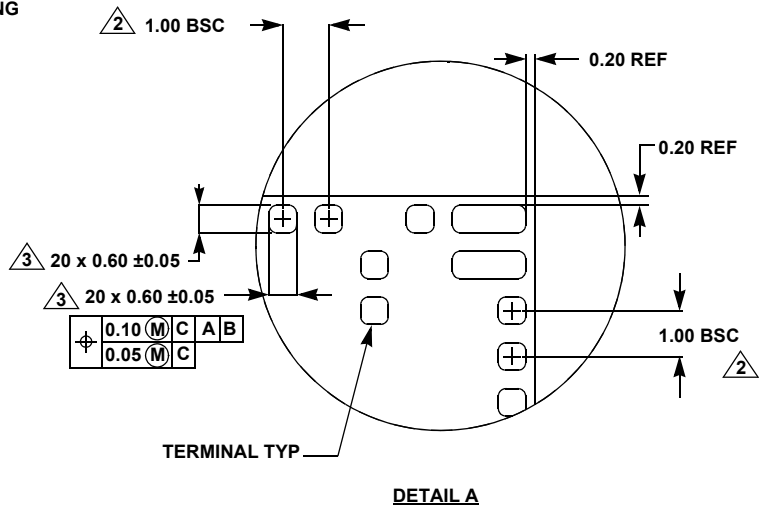
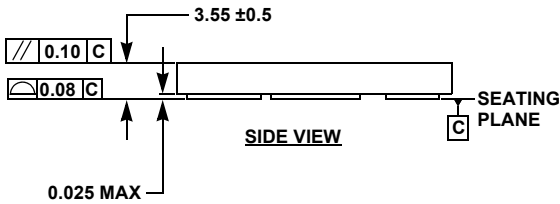
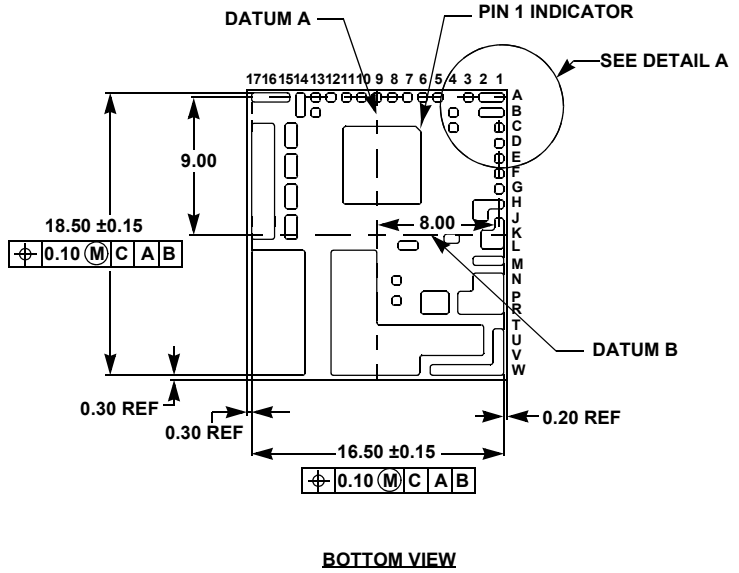
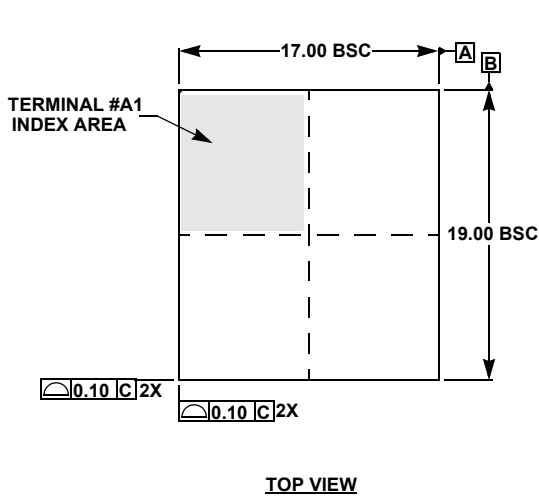

NOTES:

1. ALL DIMENSIONS ARE IN MILLIMETERS.
2. REPRESENTS THE BASIC LAND GRID PITCH.
3. THE TOTAL NUMBER OF I/O (EXCLUDING DUMMY PADS)
4. UNLESS OTHERWISE SPECIFIED, TOLERANCE: DECIMAL ±0.10
5. DIMENSIONING AND TOLERANCING PER ASME Y14.M-2009
6. THE CONFIGURATION OF THE PIN#1 IDENTIFIER IS OPTIONAL, BUT MUST BE LOCATED WITHIN THE ZONE INDICATED. THE PIN #1 IDENTIFIER MAY BE EITHER A MOLD OR MARK FEATURE.

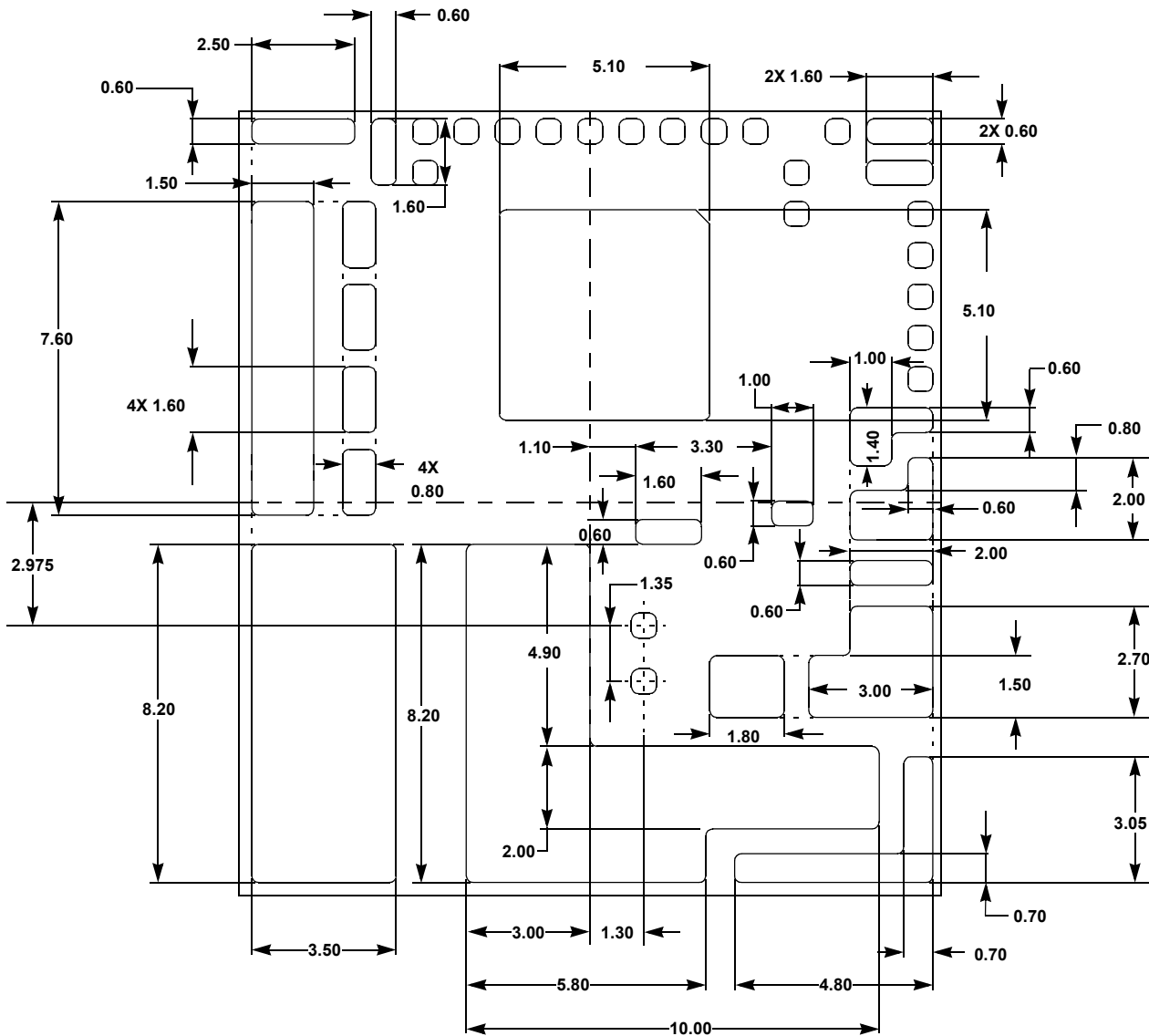

SIZE DETAILS FOR THE 16 EXPOSED DAPS

BOTTOM VIEW

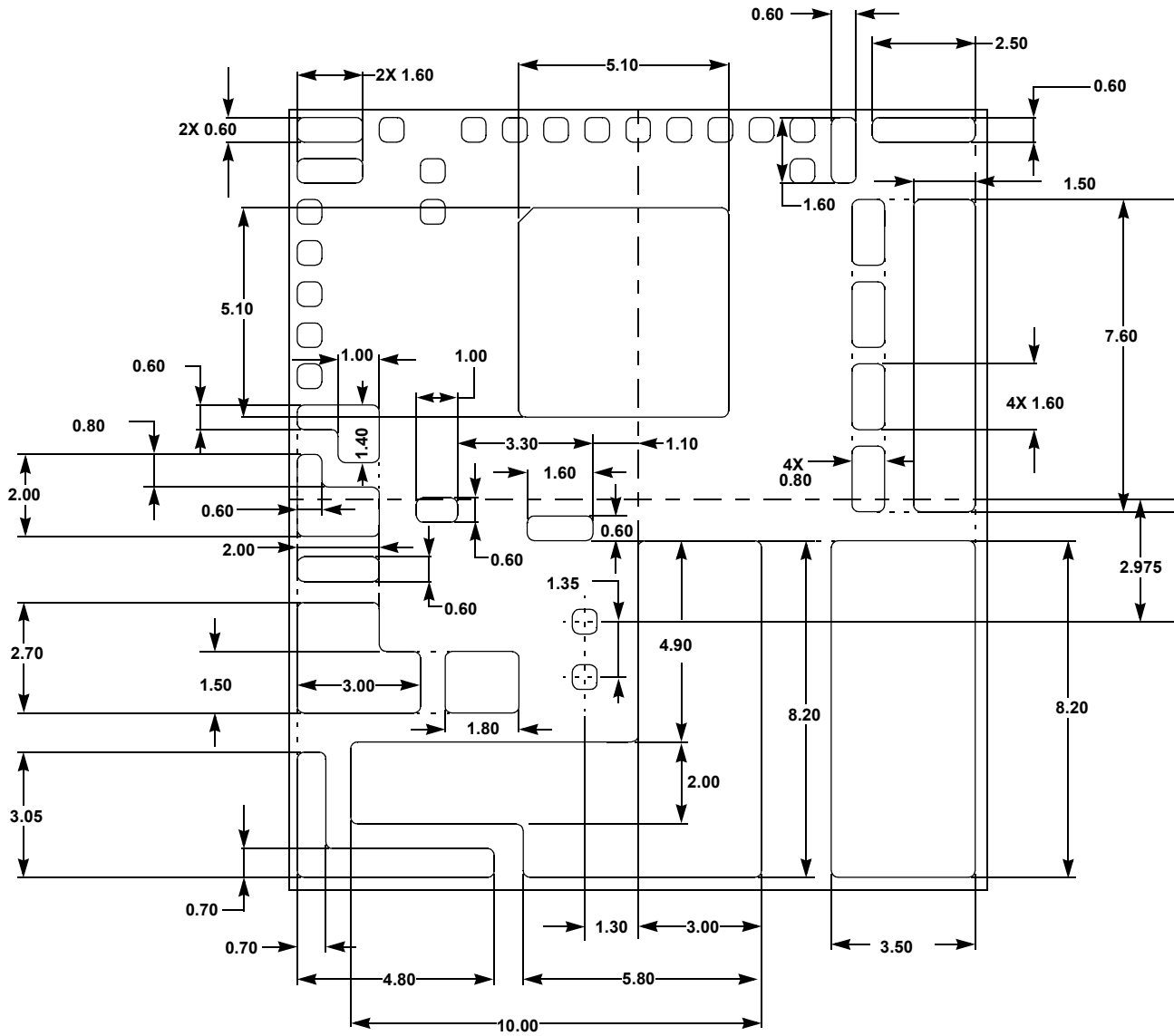

SIZE DETAILS FOR THE 16 EXPOSED DAPS

TOP VIEW

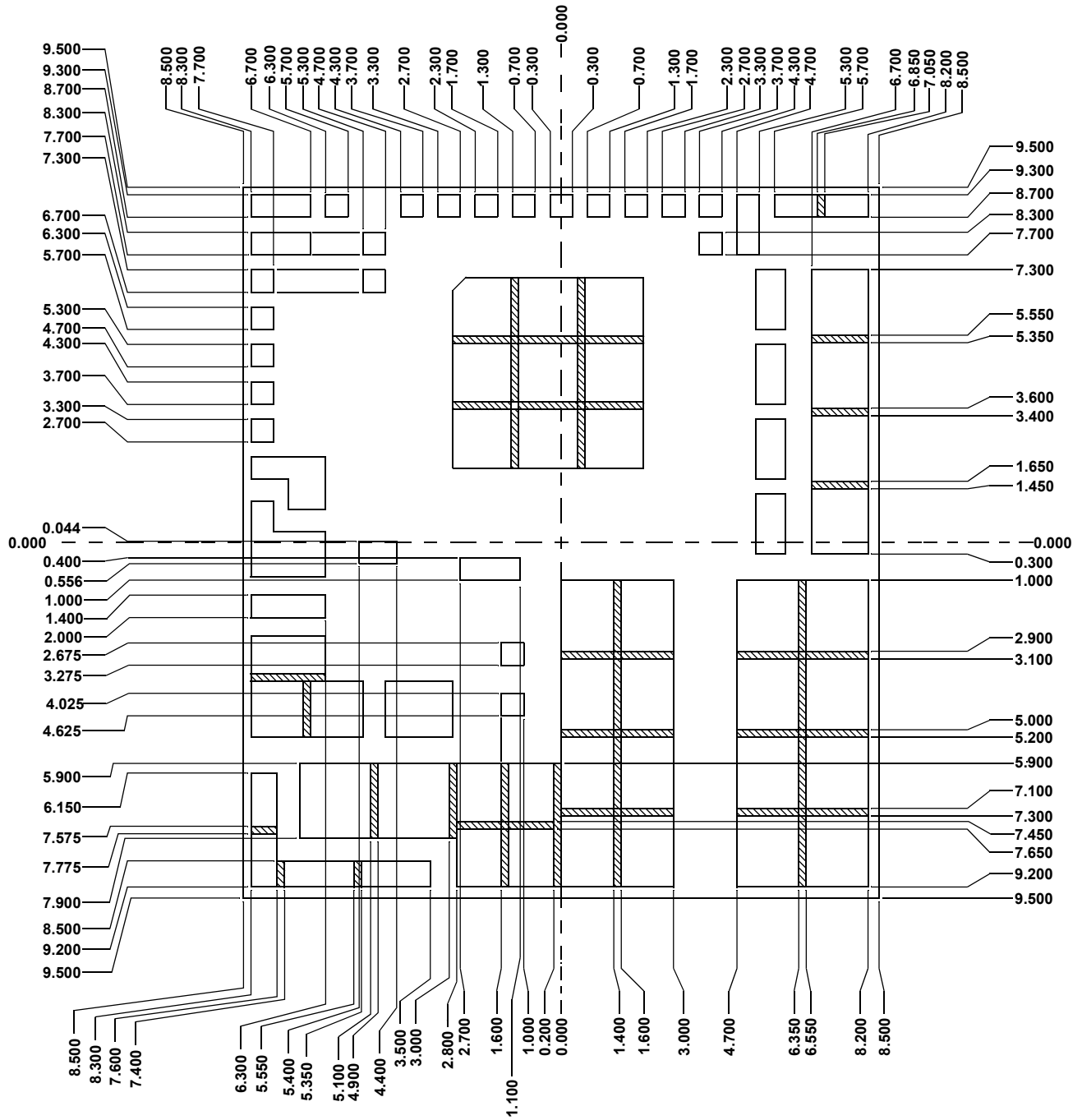

RECOMMENDED SOLDER MASK DEFINED PCB LAND PATTERN (SHEET 1 OF 2)

TOP VIEW

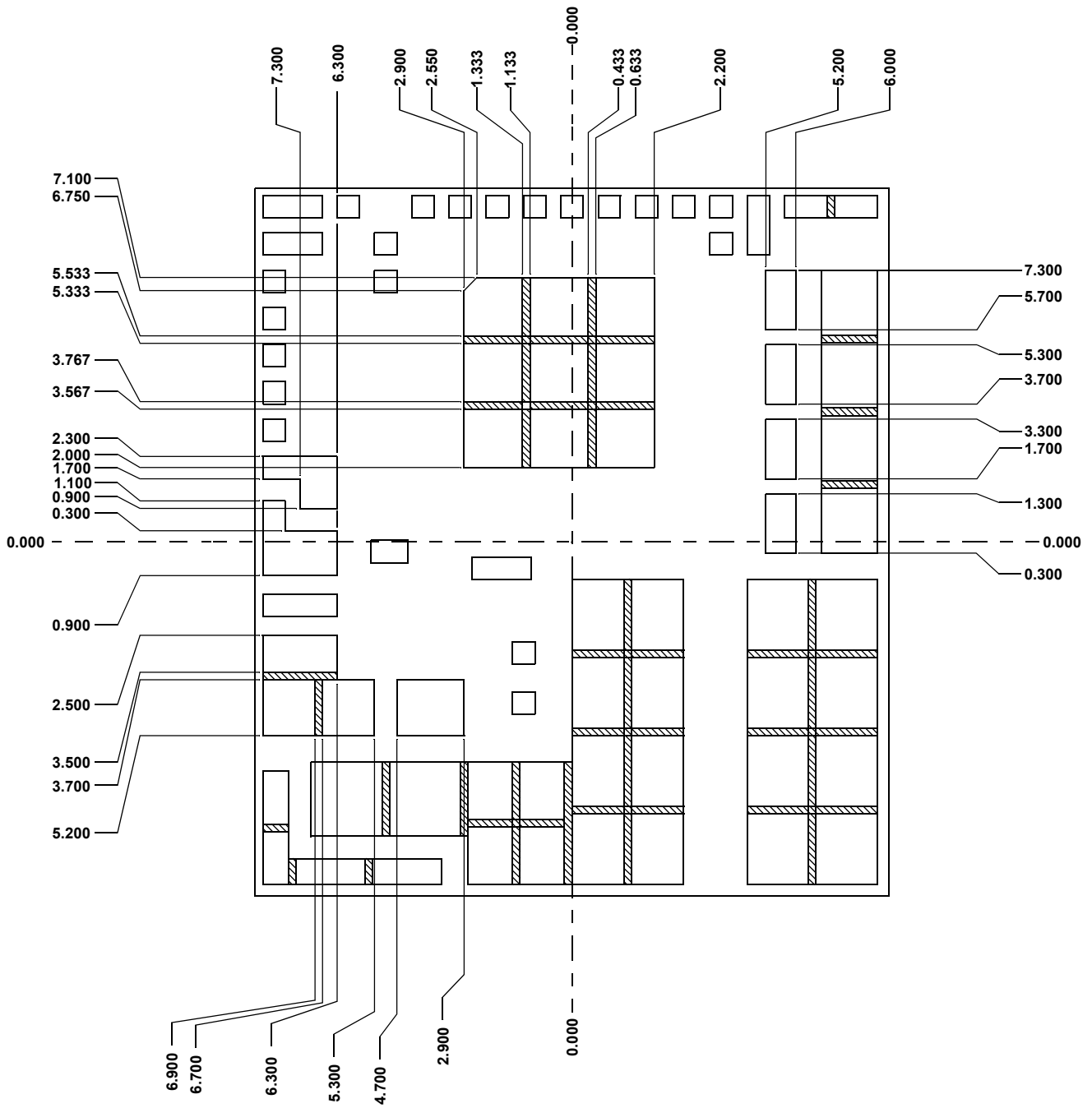

RECOMMENDED SOLDER MASK DEFINED PCB LAND PATTERN (SHEET 2 OF 2)

TOP VIEW



RECOMMENDED STENCIL PATTERN (90% PASTE TO PAD) (SHEET 1 OF 2)

TOP VIEW

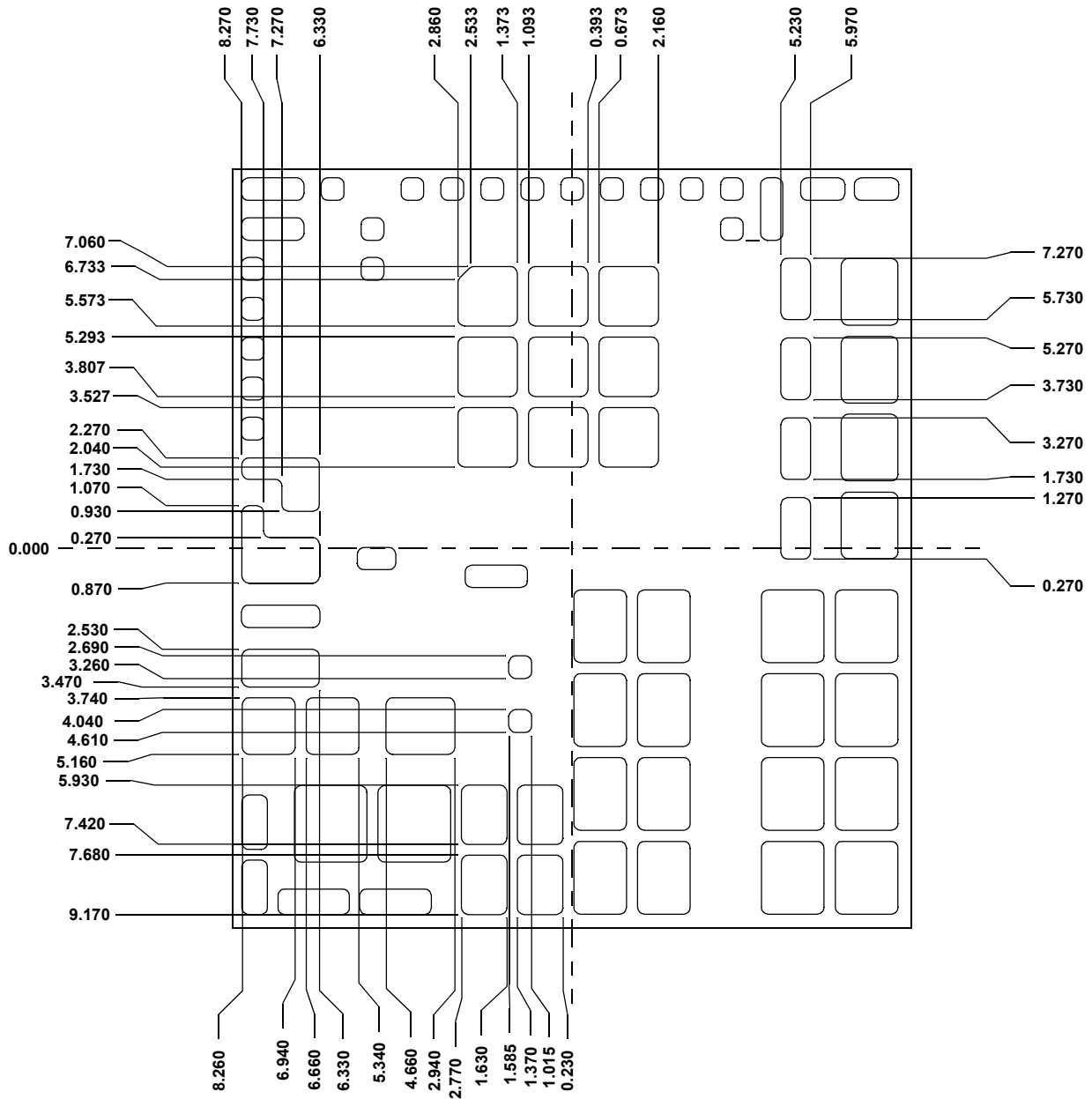

RECOMMENDED STENCIL PATTERN (90% PASTE TO PAD) (SHEET 2 OF 2)

TOP VIEW

13. Revision History

Rev.	Date	Change
2.00	Jan 29, 2018	Updated Ordering Information table, added ZL9024MEVAL1Z. Changed the UVLO pin to NC on page 6. Added a row describing the VMON pin (22) on page 7. Removed the UVLO pin description on page 7. Added pin 29 to NC row on page 7. Removed the UVLO pin from the Typical Application Circuit on page 8. Removed UVLO from the Logic I/O Voltage list on page 10. Changed the UVLO pin to NC in Figure 19 on page 24. Added Renesas disclaimer.
1.00	Dec 20, 2017	Added Table 1 (Key Differences Between Family of Parts) to page 5.
0.00	Dec 13, 2017	Initial release

Notice

1. Descriptions of circuits, software and other related information in this document are provided only to illustrate the operation of semiconductor products and application examples. You are fully responsible for the incorporation or any other use of the circuits, software, and information in the design of your product or system. Renesas Electronics disclaims any and all liability for any losses and damages incurred by you or third parties arising from the use of these circuits, software, or information.
2. Renesas Electronics hereby expressly disclaims any warranties against and liability for infringement or any other claims involving patents, copyrights, or other intellectual property rights of third parties, by or arising from the use of Renesas Electronics products or technical information described in this document, including but not limited to, the product data, drawings, charts, programs, algorithms, and application examples.
3. No license, express, implied or otherwise, is granted hereby under any patents, copyrights or other intellectual property rights of Renesas Electronics or others.
4. You shall not alter, modify, copy, or reverse engineer any Renesas Electronics product, whether in whole or in part. Renesas Electronics disclaims any and all liability for any losses or damages incurred by you or third parties arising from such alteration, modification, copying or reverse engineering.
5. Renesas Electronics products are classified according to the following two quality grades: "Standard" and "High Quality". The intended applications for each Renesas Electronics product depends on the product's quality grade, as indicated below.
"Standard": Computers; office equipment; communications equipment; test and measurement equipment; audio and visual equipment; home electronic appliances; machine tools; personal electronic equipment; industrial robots; etc.
"High Quality": Transportation equipment (automobiles, trains, ships, etc.); traffic control (traffic lights); large-scale communication equipment; key financial terminal systems; safety control equipment; etc.
Unless expressly designated as a high reliability product or a product for harsh environments in a Renesas Electronics data sheet or other Renesas Electronics document, Renesas Electronics products are not intended or authorized for use in products or systems that may pose a direct threat to human life or bodily injury (artificial life support devices or systems; surgical implantations; etc.), or may cause serious property damage (space system; undersea repeaters; nuclear power control systems; aircraft control systems; key plant systems; military equipment; etc.). Renesas Electronics disclaims any and all liability for any damages or losses incurred by you or any third parties arising from the use of any Renesas Electronics product that is inconsistent with any Renesas Electronics data sheet, user's manual or other Renesas Electronics document.
6. When using Renesas Electronics products, refer to the latest product information (data sheets, user's manuals, application notes, "General Notes for Handling and Using Semiconductor Devices" in the reliability handbook, etc.), and ensure that usage conditions are within the ranges specified by Renesas Electronics with respect to maximum ratings, operating power supply voltage range, heat dissipation characteristics, installation, etc. Renesas Electronics disclaims any and all liability for any malfunctions, failure or accident arising out of the use of Renesas Electronics products outside of such specified ranges.
7. Although Renesas Electronics endeavors to improve the quality and reliability of Renesas Electronics products, semiconductor products have specific characteristics, such as the occurrence of failure at a certain rate and malfunctions under certain use conditions. Unless designated as a high reliability product or a product for harsh environments in a Renesas Electronics data sheet or other Renesas Electronics document, Renesas Electronics products are not subject to radiation resistance design. You are responsible for implementing safety measures to guard against the possibility of bodily injury, injury or damage caused by fire, and/or danger to the public in the event of a failure or malfunction of Renesas Electronics products, such as safety design for hardware and software, including but not limited to redundancy, fire control and malfunction prevention, appropriate treatment for aging degradation or any other appropriate measures. Because the evaluation of microcomputer software alone is very difficult and impractical, you are responsible for evaluating the safety of the final products or systems manufactured by you.
8. Please contact a Renesas Electronics sales office for details as to environmental matters such as the environmental compatibility of each Renesas Electronics product. You are responsible for carefully and sufficiently investigating applicable laws and regulations that regulate the inclusion or use of controlled substances, including without limitation, the EU RoHS Directive, and using Renesas Electronics products in compliance with all these applicable laws and regulations. Renesas Electronics disclaims any and all liability for damages or losses occurring as a result of your noncompliance with applicable laws and regulations.
9. Renesas Electronics products and technologies shall not be used for or incorporated into any products or systems whose manufacture, use, or sale is prohibited under any applicable domestic or foreign laws or regulations. You shall comply with any applicable export control laws and regulations promulgated and administered by the governments of any countries asserting jurisdiction over the parties or transactions.
10. It is the responsibility of the buyer or distributor of Renesas Electronics products, or any other party who distributes, disposes of, or otherwise sells or transfers the product to a third party, to notify such third party in advance of the contents and conditions set forth in this document.
11. This document shall not be reprinted, reproduced or duplicated in any form, in whole or in part, without prior written consent of Renesas Electronics.
12. Please contact a Renesas Electronics sales office if you have any questions regarding the information contained in this document or Renesas Electronics products.
(Note 1) "Renesas Electronics" as used in this document means Renesas Electronics Corporation and also includes its directly or indirectly controlled subsidiaries.
(Note 2) "Renesas Electronics product(s)" means any product developed or manufactured by or for Renesas Electronics.

(Rev.4.0-1 November 2017)



SALES OFFICES

Renesas Electronics Corporation

<http://www.renesas.com>

Refer to "<http://www.renesas.com/>" for the latest and detailed information.

Renesas Electronics America Inc.
1001 Murphy Ranch Road, Milpitas, CA 95035, U.S.A.
Tel: +1-408-432-8888, Fax: +1-408-434-5351

Renesas Electronics Canada Limited
9251 Yonge Street, Suite 8309 Richmond Hill, Ontario Canada L4C 9T3
Tel: +1-905-237-2004

Renesas Electronics Europe Limited
Dukes Meadow, Millboard Road, Bourne End, Buckinghamshire, SL8 5FH, U.K
Tel: +44-1628-651-700, Fax: +44-1628-651-804

Renesas Electronics Europe GmbH
Arcadiastrasse 10, 40472 Düsseldorf, Germany
Tel: +49-211-6503-0, Fax: +49-211-6503-1327

Renesas Electronics (China) Co., Ltd.
Room 1709 Quantum Plaza, No.27 ZhichunLu, Haidian District, Beijing, 100191 P. R. China
Tel: +86-10-8235-1155, Fax: +86-10-8235-7679

Renesas Electronics (Shanghai) Co., Ltd.
Unit 301, Tower A, Central Towers, 555 Langao Road, Putuo District, Shanghai, 200333 P. R. China
Tel: +86-21-2226-0888, Fax: +86-21-2226-0999

Renesas Electronics Hong Kong Limited
Unit 1601-1611, 16/F., Tower 2, Grand Century Place, 193 Prince Edward Road West, Mongkok, Kowloon, Hong Kong
Tel: +852-2265-6688, Fax: +852-2886-9022

Renesas Electronics Taiwan Co., Ltd.
13F, No. 363, Fu Shing North Road, Taipei 10543, Taiwan
Tel: +886-2-8175-9600, Fax: +886-2-8175-9670

Renesas Electronics Singapore Pte. Ltd.
80 Bendemeer Road, Unit #06-02 Hyflux Innovation Centre, Singapore 339949
Tel: +65-6213-0200, Fax: +65-6213-0300

Renesas Electronics Malaysia Sdn.Bhd.
Unit 1207, Block B, Menara Amcorp, Amcorp Trade Centre, No. 18, Jln Persiaran Barat, 46050 Petaling Jaya, Selangor Darul Ehsan, Malaysia
Tel: +60-3-7955-9390, Fax: +60-3-7955-9510

Renesas Electronics India Pvt. Ltd.
No.777C, 100 Feet Road, HAL 2nd Stage, Indiranagar, Bangalore 560 038, India
Tel: +91-80-67208700, Fax: +91-80-67208777

Renesas Electronics Korea Co., Ltd.
17F, KAMCO Yangjae Tower, 262, Gangnam-daero, Gangnam-gu, Seoul, 06265 Korea
Tel: +82-2-558-3737, Fax: +82-2-558-5338



Компания «ЭлектроПласт» предлагает заключение долгосрочных отношений при поставках импортных электронных компонентов на взаимовыгодных условиях!

Наши преимущества:

- Оперативные поставки широкого спектра электронных компонентов отечественного и импортного производства напрямую от производителей и с крупнейших мировых складов;
- Поставка более 17-ти миллионов наименований электронных компонентов;
- Поставка сложных, дефицитных, либо снятых с производства позиций;
- Оперативные сроки поставки под заказ (от 5 рабочих дней);
- Экспресс доставка в любую точку России;
- Техническая поддержка проекта, помощь в подборе аналогов, поставка прототипов;
- Система менеджмента качества сертифицирована по Международному стандарту ISO 9001;
- Лицензия ФСБ на осуществление работ с использованием сведений, составляющих государственную тайну;
- Поставка специализированных компонентов (Xilinx, Altera, Analog Devices, Intersil, Interpoint, Microsemi, Aeroflex, Peregrine, Syfer, Eurofarad, Texas Instrument, Miteq, Cobham, E2V, MA-COM, Hittite, Mini-Circuits, General Dynamics и др.);

Помимо этого, одним из направлений компании «ЭлектроПласт» является направление «Источники питания». Мы предлагаем Вам помощь Конструкторского отдела:

- Подбор оптимального решения, техническое обоснование при выборе компонента;
- Подбор аналогов;
- Консультации по применению компонента;
- Поставка образцов и прототипов;
- Техническая поддержка проекта;
- Защита от снятия компонента с производства.



Как с нами связаться

Телефон: 8 (812) 309 58 32 (многоканальный)

Факс: 8 (812) 320-02-42

Электронная почта: org@eplast1.ru

Адрес: 198099, г. Санкт-Петербург, ул. Калинина, дом 2, корпус 4, литера А.