



Main

Range of product	OsiSense XC
Series name	Standard format
Product or component type	Wireless limit switch
Device short name	XCKW
Body type	Fixed
Head type	Plunger head

Complementary

Body material	Plastic
Head material	Plastic
Lever material	Metal
Fixing mode	By 4 screws
Type of operator	Metal spring return roller plunger
Switch actuation	By 30° cam
Type of approach	2 directions lateral approach
Communication network type	ZigBee green power 2.4 GHz conforming to IEEE 802.15.4
Electrical composition code	PW1
Emission power	3 mW
Response time	<= 2 ms
Maximum sensing distance	328.08 ft (100 m) in free field 82.02 ft (25 m) in industrial environment 300 m with external antenna
Contact operation	Snap action
Number of steps	1
Maximum force for tripping	50 N
Maximum actuation speed	1.64 ft/s (0.5 m/s)
Operating rate	<= 60 cyc/mn
Mechanical durability	400000 cycles
Switching operation per year	3600
Width	1.57 in (40 mm)
Height	4.92 in (125 mm)
Depth	1.61 in (41 mm)
Product weight	0.49 lb(US) (0.22 kg)

Environment

electromagnetic compatibility	Immunity for industrial environments Radiated emission Susceptibility to electromagnetic fields: 3 V/m, 80...2700 MHz, distance = 20 m Susceptibility to electromagnetic fields: 10 V/m, 80...2000 MHz Electrostatic discharge immunity test: 6 kV, on contact (on metal parts) Electrostatic discharge immunity test: 8 kV, in free air (in insulating parts)
shock resistance	50 gn (duration = 11 ms) conforming to IEC 60068-2-27
vibration resistance	+/- 10 mm (vibration frequency: 2...11 Hz) conforming to IEC 60068-2-6 25 gn (vibration frequency: 10...500 Hz) conforming to IEC 60068-2-6
IP degree of protection	IP66 conforming to IEC 60529 IP67 conforming to IEC 60529
IK degree of protection	IK05 conforming to EN 50102
ambient air temperature for operation	-13...131 °F (-25...55 °C)

ambient air temperature for storage	-40...158 °F (-40...70 °C)
directives	2004/108/EC - electromagnetic compatibility 1999/5/EC - R&TTE directive
standards	EN/IEC 60947-1 EN/IEC 60947-5-1
radio agreement	IC RSS FCC RCM

Offer Sustainability

Not Green Premium product	Not Green Premium product
Compliant - since 1545 - Schneider Electric declaration of conformity	Compliant - since 1545 - Schneider Electric declaration of conformity
Reference not containing SVHC above the threshold	Reference not containing SVHC above the threshold
WARNING: This product can expose you to chemicals including:	WARNING: This product can expose you to chemicals including:
Diisononyl phthalate (DINP), which is known to the State of California to cause cancer, and	Diisononyl phthalate (DINP), which is known to the State of California to cause cancer, and
Di-isodecyl phthalate (DIDP), which is known to the State of California to cause birth defects or other reproductive harm.	Di-isodecyl phthalate (DIDP), which is known to the State of California to cause birth defects or other reproductive harm.
For more information go to www.p65warnings.ca.gov	For more information go to www.p65warnings.ca.gov

Dimensions

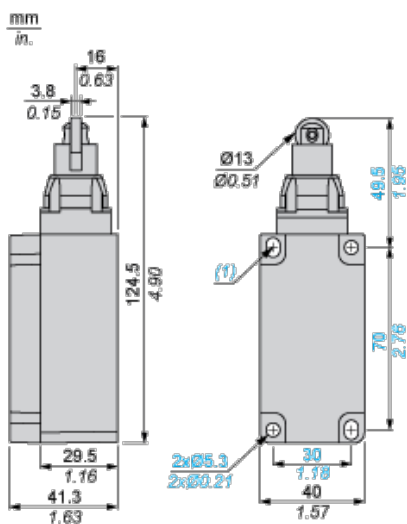

(1) 2 elongated holes 5.3 x 7.3 mm / 0.21 x 0.29 in.

Mounting with Rotary Head and Roller Lever

Recommended Mounting

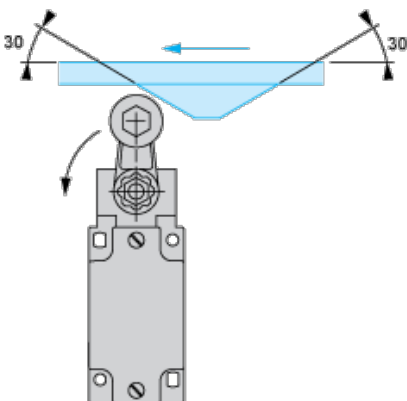

Mounting to be Avoided

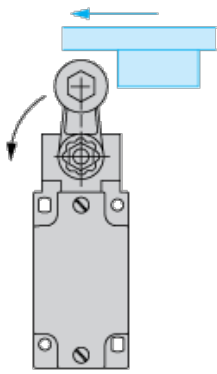

Mounting

Head Orientation

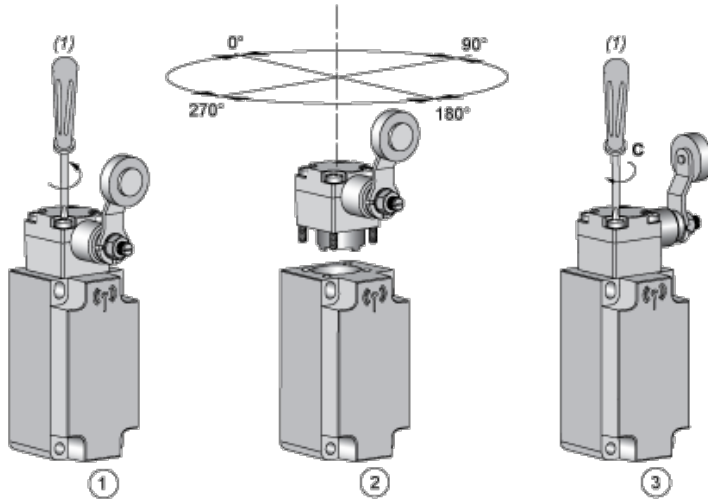

- (1) PZ1, pozidriv screwdriver, size 1
 C : 1 Nm ($\pm 20\%$) / 8.85 lb-in ($\pm 20\%$)

Mounting

Characteristics of Actuation

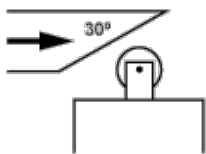

Technical Description

Functionnal Diagram, Travel Distance

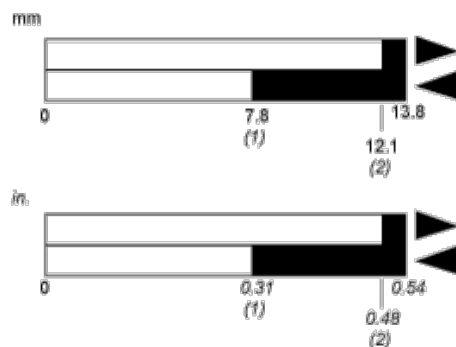

- (1) Reset
 (2) Set



Компания «ЭлектроПласт» предлагает заключение долгосрочных отношений при поставках импортных электронных компонентов на взаимовыгодных условиях!

Наши преимущества:

- Оперативные поставки широкого спектра электронных компонентов отечественного и импортного производства напрямую от производителей и с крупнейших мировых складов;
- Поставка более 17-ти миллионов наименований электронных компонентов;
- Поставка сложных, дефицитных, либо снятых с производства позиций;
- Оперативные сроки поставки под заказ (от 5 рабочих дней);
- Экспресс доставка в любую точку России;
- Техническая поддержка проекта, помощь в подборе аналогов, поставка прототипов;
- Система менеджмента качества сертифицирована по Международному стандарту ISO 9001;
- Лицензия ФСБ на осуществление работ с использованием сведений, составляющих государственную тайну;
- Поставка специализированных компонентов (Xilinx, Altera, Analog Devices, Intersil, Interpoint, Microsemi, Aeroflex, Peregrine, Syfer, Eurofarad, Texas Instrument, Miteq, Cobham, E2V, MA-COM, Hittite, Mini-Circuits, General Dynamics и др.);

Помимо этого, одним из направлений компании «ЭлектроПласт» является направление «Источники питания». Мы предлагаем Вам помощь Конструкторского отдела:

- Подбор оптимального решения, техническое обоснование при выборе компонента;
- Подбор аналогов;
- Консультации по применению компонента;
- Поставка образцов и прототипов;
- Техническая поддержка проекта;
- Защита от снятия компонента с производства.



Как с нами связаться

Телефон: 8 (812) 309 58 32 (многоканальный)

Факс: 8 (812) 320-02-42

Электронная почта: org@eplast1.ru

Адрес: 198099, г. Санкт-Петербург, ул. Калинина, дом 2, корпус 4, литера А.