

Figure 1

### 1. INTRODUCTION

AMP\* Die Assemblies 90230-1 and 90231-2 (shown in Figure 1) are used with Hand Crimping Tool 69710-1 or 626 Pneumatic Tooling Assembly 189721-1 to crimp screw machine Type II pin and socket contacts onto *stranded* wire sizes 32 through 14 AWG with an insulation diameter range of 0.76 through 1.91 mm [.030 through .075 in.].

For contact part numbers, refer to AMP Catalog 65910, or call Product Information at the number listed at the bottom of this page.

For specific information concerning the hand tool, refer to AMP Instruction Sheet 408-2095; and for the pneumatic tooling assembly, refer to Customer Manual 409-5862. Read these instructions and referenced materials before crimping the contacts.

**NOTE**

*Dimensions on this sheet are in millimeters [with inches in brackets]. Figures are not drawn to scale.*

Reasons for reissue of this instruction sheet are provided in Section 6, REVISION SUMMARY.

### 2. DESCRIPTION

The die assembly consists of a stationary die and a movable die. The stationary die has chamfered corners and features a locator and wire size color dot

code. The moving die has square corners and features an alignment plate and wire size range marking. Each die is held in the tooling by a die holding screw. The screws are color coded to correspond with the color code on the contact shoulder. When mated, the die assembly forms a crimping chamber with a wire barrel section and an insulation barrel section.

**NOTE**

*The color code on the contact wire barrel or insulation barrel designates the wire size range for the contact.*

### 3. CRIMPING PROCEDURE

Select wire of specified size and insulation diameter and applicable contact. Strip the insulation from the wire to the length indicated in Figure 2. Be careful not to nick or cut the wire strands.

#### Typical Screw Machine Type II Contacts

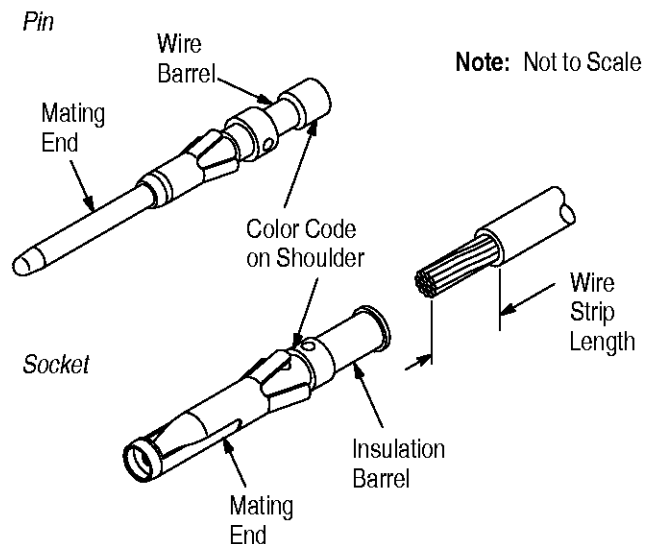

WIRE			DIE ASSEMBLY	
SIZE (AWG)	INSULATION DIAMETER	STRIP LENGTH ( $\pm 0.13$ [ $\pm .005$ ])	PART NUMBER	SCREW COLOR CODE
32-20	0.76-1.91 [.030-.075]	5.16 [.203]	90230-1	Red
18-14	—	6.35 [.250]	90231-2	Blue
(2) 18	—			

— Wire used with contacts without an insulation barrel.

Figure 2

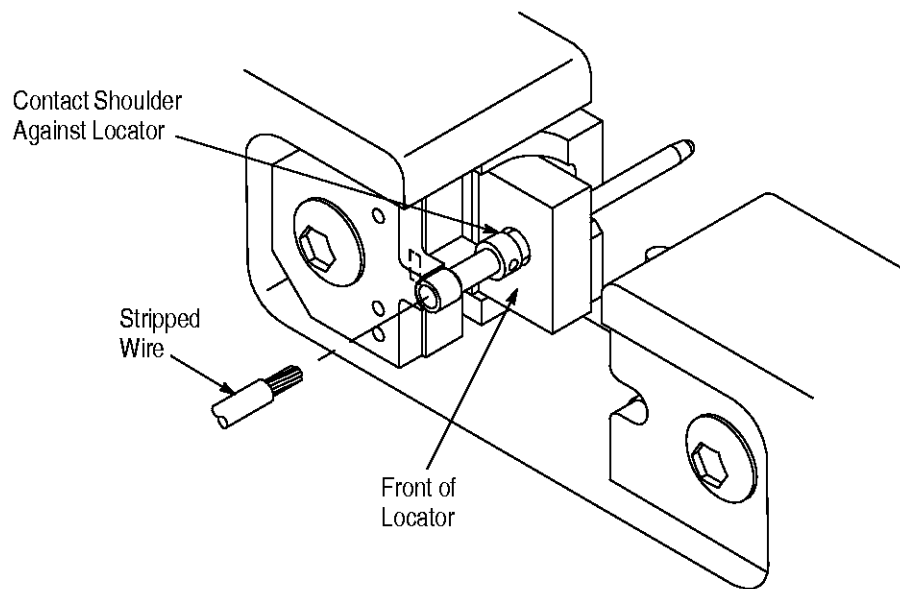

Figure 3

Make sure that the color code on the die assembly corresponds with the contact shoulder color code. Install the die assembly in the tooling according to the instructions packaged with the tooling. Then proceed as follows:

1. Insert the contact (mating end first) into the **FRONT** of the locator until the contact shoulder butts against the locator. See Figure 3.
2. Hold the contact in position and close the dies just enough to hold the contact in place without deforming the contact.
3. Insert a properly stripped wire into the contact insulation barrel or wire barrel until it bottoms.
4. Hold the wire in place and actuate the tooling through a complete cycle.
5. Allow the dies to open **FULLY**, then remove the crimped contact. Inspect the crimped contact according to Figure 4.

**NOTE**

For detailed information on inspection requirements, refer to Application Specification 114-10026.

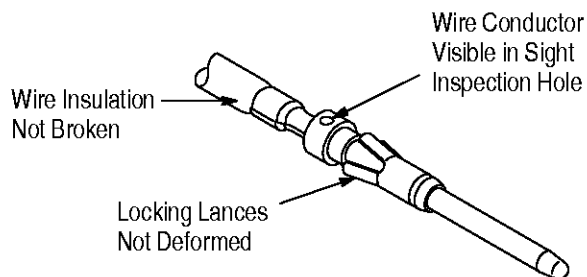

Figure 4

**4. MAINTENANCE AND INSPECTION****4.1. Daily Maintenance**

It is recommended that each operator of the die assembly be made aware of, and responsible for, the following steps of daily maintenance:

1. Remove all foreign particles from the dies with a clean, soft brush, or a clean, soft, lint-free cloth. Do not use objects that could damage the dies.
2. Make sure that the proper die holding screws are in place and are secured with the proper retaining rings. Check die alignment and tighten die holding screws (twice daily is recommended for production use).
3. Make certain that the dies are protected with a thin coat of any good SAE 20 motor oil. Do NOT oil excessively.
4. When dies are not in use, store them in a clean, dry area.

**4.2. Periodic Inspection**

Regular inspections should be performed by quality control personnel with a record of scheduled inspection remaining with the die assembly or supplied to personnel responsible for them. Though recommendations call for at least one inspection per month, inspection frequency should be based upon amount of use, working conditions, operator training and skill, and established company standards. The inspections should be performed in the following sequence.

1. Remove all lubrication and accumulated film by immersing the dies in a suitable commercial degreaser that will not affect paint or plastic material.

2. Make sure that all die holding screws, retaining rings, and die components are in place.
3. Check all bearing surfaces for wear. Replace worn components.
4. Inspect the crimping chamber for flattened, chipped, cracked, worn, or broken areas. If damage is evident, the dies must be repaired before returning them to service.

**4.3. Gaging the Crimping Chamber**

This inspection requires the use of plug gages conforming to the dimensions provided in Figure 5. AMP does not manufacture or market these gages. To gage the crimping chamber, proceed as follows:

1. Remove traces of oil or dirt from the crimping chamber and plug gage.
2. Mate the dies until the crimping surfaces have bottomed; then hold in this position. Do NOT force beyond initial contact.
3. Insert GO element into the crimping chamber; but do not force it. For the wire barrel section of the crimping chamber, the GO element must pass completely through the crimping chamber. For the insulation barrel section, the GO element must pass through the length of the section but will stop against the wire barrel section.
4. In the same manner, try to insert the NO-GO element into the crimping chamber. The NO-GO element may enter partially, but must not pass completely through the length of the crimping chamber.

If the crimping chamber conforms to the gage inspection, the dies may be considered dimensionally correct and should be lubricated with a THIN coat of any good SAE 20 motor oil. If the crimping chamber does NOT conform to the gage inspection, the dies must be returned to AMP for further evaluation and repair.

For additional information regarding the use of a plug gage, refer to 408-7424.

**5. REPLACEMENT AND REPAIR**

Customer-replaceable parts are listed in Figure 6. A complete inventory should be stocked and controlled to prevent lost time when replacement of parts is necessary. Order replacement parts or additional die assemblies through your AMP representative, or call 1-800-526-5142, or send a facsimile of your purchase order to 717-986-7605 or write to:

CUSTOMER SERVICE (038-035)  
 AMP INCORPORATED  
 PO BOX 3608  
 HARRISBURG PA 17105-3608

**Suggested Plug Gage Design for Wire Barrel Section**

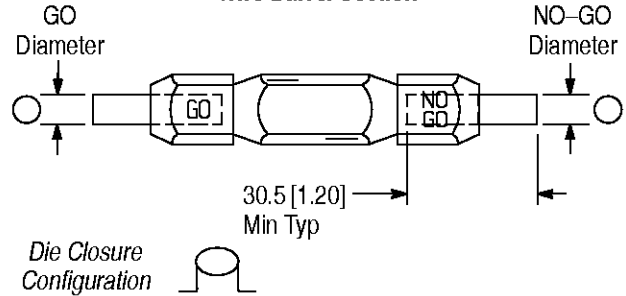

DIE ASSEMBLY	GAGE ELEMENT DIAMETER	
	GO	NO-GO
90230-1	1.003-1.011 [.0395-.0398]	1.072-1.080 [.0422-.0425]
90231-2	1.537-1.544 [.0605-.0608]	1.605-1.613 [.0632-.0635]

**Suggested Plug Gage Design for Insulation Barrel Section**

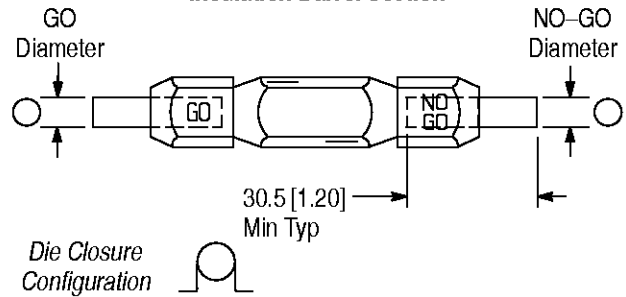

DIE ASSEMBLY	GAGE ELEMENT DIAMETER	
	GO	NO-GO
90230-1	1.753-1.760 [.0690-.0693]	2.000-2.007 [.0787-.0790]
90231-2	2.921-2.929 [.1150-.1153]	3.167-3.175 [.1247-.1250]

**Inspection of Crimping Chamber**

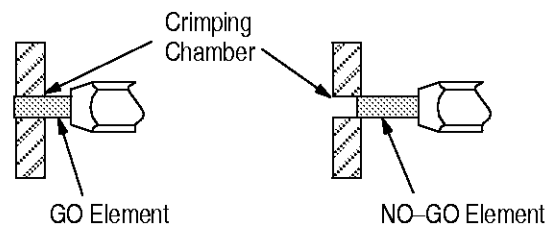

Wire barrel GO element must pass completely through the crimping chamber.  
 Insulation barrel GO element must pass through the length of the section, then stop.

NO-GO element may enter partially, but must not pass completely through the crimping chamber.

Figure 5

Die assemblies may be returned to AMP for evaluation and repair. For repairs, send die assembly, with a written description of the problem, to:

CUSTOMER REPAIR (01-12)  
 AMP INCORPORATED  
 1523 NORTH 4TH STREET  
 HARRISBURG PA 17102-1604

- Removed Die Assembly 90111
- Replaced tooling information in Section 1
- Replaced previous Figure 1 with reference to catalog
- Replaced previous Sections 3 and 6 with reference to instructions packaged with tooling
- Added information to Step 5 in Section 3
- Added Paragraph 4.3
- Added Section 5

**6. REVISION SUMMARY**

Revisions to this instruction sheet per EC 0990-0751-97 include:

- Replaced "AMP-INCERT" with "screw machine Type II"

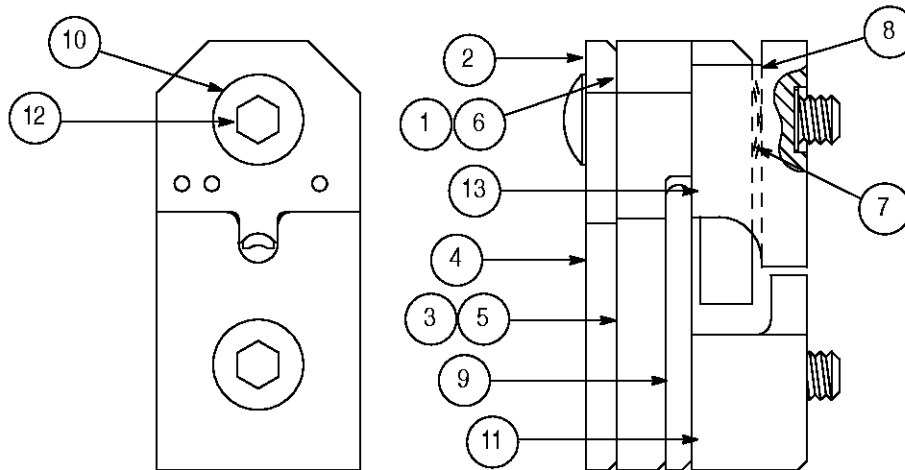

**CUSTOMER REPLACEMENT PARTS**

ITEM	PART NUMBER FOR DIE ASSEMBLY		DESCRIPTION	QTY PER ASSEMBLY
	90230-1	90231-2		
1	125399-1	125399-5	ANVIL, Wire	1
2	45284	125402-2	ANVIL, Insulation	1
3	125398-1	125398-4	CRIMPER, Wire	1
4	45283	125401-2	CRIMPER, Insulation	1
5	—	125398-4	WIRE, Crimper	1
6	—	125399-5	WIRE, Anvil	1
7	24088-8		WASHER, Curved	1
8	125704-1		LOCATOR	1
9	125180-2		PLATE, Alignment	1
10	1-21046-3		RING, Retaining	2
11	125702-1		SPACER, Support	1
12	2-306131-9		SCREW, Die Holding, Special	2
13	125703-1		HOUSING, Locator	1

Figure 6



Компания «ЭлектроПласт» предлагает заключение долгосрочных отношений при поставках импортных электронных компонентов на взаимовыгодных условиях!

Наши преимущества:

- Оперативные поставки широкого спектра электронных компонентов отечественного и импортного производства напрямую от производителей и с крупнейших мировых складов;
- Поставка более 17-ти миллионов наименований электронных компонентов;
- Поставка сложных, дефицитных, либо снятых с производства позиций;
- Оперативные сроки поставки под заказ (от 5 рабочих дней);
- Экспресс доставка в любую точку России;
- Техническая поддержка проекта, помощь в подборе аналогов, поставка прототипов;
- Система менеджмента качества сертифицирована по Международному стандарту ISO 9001;
- Лицензия ФСБ на осуществление работ с использованием сведений, составляющих государственную тайну;
- Поставка специализированных компонентов (Xilinx, Altera, Analog Devices, Intersil, Interpoint, Microsemi, Aeroflex, Peregrine, Syfer, Eurofarad, Texas Instrument, Miteq, Cobham, E2V, MA-COM, Hittite, Mini-Circuits, General Dynamics и др.);

Помимо этого, одним из направлений компании «ЭлектроПласт» является направление «Источники питания». Мы предлагаем Вам помощь Конструкторского отдела:

- Подбор оптимального решения, техническое обоснование при выборе компонента;
- Подбор аналогов;
- Консультации по применению компонента;
- Поставка образцов и прототипов;
- Техническая поддержка проекта;
- Защита от снятия компонента с производства.



#### Как с нами связаться

**Телефон:** 8 (812) 309 58 32 (многоканальный)

**Факс:** 8 (812) 320-02-42

**Электронная почта:** [org@eplast1.ru](mailto:org@eplast1.ru)

**Адрес:** 198099, г. Санкт-Петербург, ул. Калинина, дом 2, корпус 4, литера А.