

NB3U1548C

3.3V/2.5V/1.8V/1.5V 160 MHz 1:4 LVC MOS/LVTTL Low Skew Over Voltage Tolerant Fanout Buffer

Description

The NB3U1548C is an LVC MOS, overvoltage tolerant clock fanout buffer targeted for clock generation in high performance telecommunication, networking and computing applications. The device is optimized for low skew clock distribution in low voltage applications. The input overvoltage tolerance enables using this device in mixed mode voltage applications. An output enable pin controls whether the outputs are in the active or high impedance state. Guaranteed output skew characteristics make the NB3U1548C ideal for those applications demanding well defined performance and repeatability. The NB3U1548C is packaged in a small SOIC-8 and in a TSSOP-8 package.

Features

- Low skew 1:4 Fanout Buffer
- Supports 3.3 V, 2.5 V, 1.8 V and 1.5 V Power Supplies
- LVC MOS Input and Output Levels
- 3.6 V Overvoltage Tolerance at the Clock and Control Inputs
- Supports Clock Frequencies up to 160 MHz
- LVC MOS Compatible Control Input for Output Disable
- Output Disabled to a High Impedance State
- -40°C to 85°C Ambient Operating Temperature
- Available in Pb-Free RoHS Compliant Packages (SOIC-8, TSSOP-8)
- These Devices are Pb-Free and are RoHS Compliant

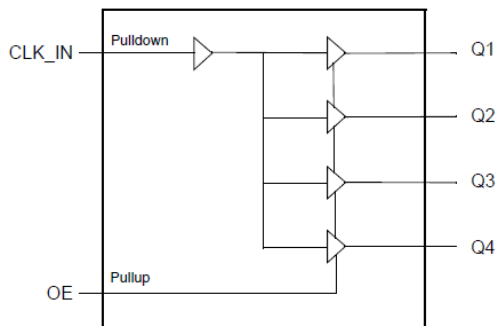

Figure 1. Block Diagram



ON Semiconductor®

www.onsemi.com

MARKING DIAGRAMS



SOIC-8
D SUFFIX
CASE 751

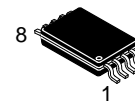
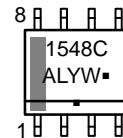

TSSOP-8
DT SUFFIX
CASE 948S

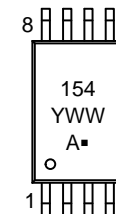

A = Assembly Location
L = Wafer Lot
Y = Year
W, WW = Work Week
▪ = Pb-Free Package

(Note: Microdot may be in either location)

ORDERING INFORMATION

See detailed ordering and shipping information on page 9 of this data sheet.

NB3U1548C

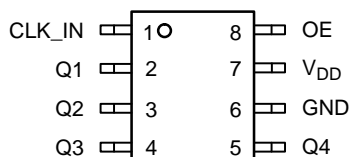

Figure 2. Pin Configuration (Top View)

Table 1. PIN DESCRIPTIONS

Number	Name	Type		Description
1	CLK_IN	Input	Pulldown	Single-ended clock input. LVCMOS interface levels.
2	Q1	Output		Single-ended clock output. LVCMOS interface levels.
3	Q2	Output		Single-ended clock output. LVCMOS interface levels.
4	Q3	Output		Single-ended clock output. LVCMOS interface levels.
5	Q4	Output		Single-ended clock output. LVCMOS interface levels.
6	GND	Power		Power supply ground.
7	VDD	Power		Power supply pin.
8	OE	Input	Pullup	Output enable pin. See Table 3. LVCMOS interface levels.

NOTE: Pullup and Pulldown refer to internal input resistors. See Table 2, Pin Characteristics, for typical values.

Table 2. PIN CHARACTERISTICS

Symbol	Parameter	Test Conditions	Min	Typ	Max	Units
CIN	Input Capacitance			4		pF
CPD	Power Dissipation Capacitance	$V_{DD} = 3.465\text{ V}$		14		pF
		$V_{DD} = 2.375\text{ V}$		13		pF
		$V_{DD} = 1.95\text{ V}$		13		pF
		$V_{DD} = 1.6\text{ V}$		12		pF
RPULLUP	Input Pullup Resistor			51		k Ω
RPULLDOWN	Input Pulldown Resistor			51		k Ω
ROUT	Output Impedance	$V_{DD} = 3.3\text{ V} \pm 5\%$		9		Ω
		$V_{DD} = 2.5\text{ V} \pm 5\%$		10		Ω
		$V_{DD} = 1.8\text{ V} \pm 0.15\text{ V}$		12		Ω
		$V_{DD} = 1.5 \pm 0.1\text{ V}$		15		Ω

Function Table

Table 3. OE CONFIGURATION TABLE

Input	Operation
OE	
0	Q[4:1] disabled (high-impedance)
1 (default)	Q[4:1] enabled

NOTE: OE is an asynchronous control.

NB3U1548C

Table 4. ABSOLUTE MAXIMUM RATINGS

Item	Rating
Supply Voltage, V_{DD}	4.6 V
Inputs, V_I	3.6 V
Outputs, V_O	-0.5 V to $V_{DD} + 0.5$ V
Package Thermal Impedance, θ_{JA} 8 Lead SOIC 8 Lead TSSOP	102.5°C/W (0 mps) 151.2°C/W (0 mps)
Storage Temperature, T_{STG}	-65°C to 150°C

Stresses exceeding those listed in the Maximum Ratings table may damage the device. If any of these limits are exceeded, device functionality should not be assumed, damage may occur and reliability may be affected.

1. JEDEC standard multilayer board – 2S2P (2 signal, 2 power) with 6 cm² copper area.
2. For additional information, see Application Note AND8003/D.

Table 5. DC ELECTRICAL CHARACTERISTICS

Symbol	Parameter	Test Conditions	Min	Typ	Max	Units
--------	-----------	-----------------	-----	-----	-----	-------

POWER SUPPLY DC CHARACTERISTICS, $V_{DD} = 3.3$ V \pm 5%, $T_A = -40^\circ\text{C}$ to 85°C

V_{DD}	Power Supply Voltage		3.135	3.3	3.465	V
I_{DDQ}	Quiescent Power Supply Current	Inputs Open, Outputs Unloaded			1	mA

POWER SUPPLY DC CHARACTERISTICS, $V_{DD} = 2.5$ V \pm 5%, $T_A = -40^\circ\text{C}$ to 85°C

V_{DD}	Power Supply Voltage		2.375	2.5	2.625	V
I_{DDQ}	Quiescent Power Supply Current	Inputs Open, Outputs Unloaded			1	mA

POWER SUPPLY DC CHARACTERISTICS, $V_{DD} = 1.8$ V \pm 0.15 V, $T_A = -40^\circ\text{C}$ to 85°C

V_{DD}	Power Supply Voltage		1.65	1.8	1.95	V
I_{DDQ}	Quiescent Power Supply Current	Inputs Open, Outputs Unloaded			1	mA

POWER SUPPLY DC CHARACTERISTICS, $V_{DD} = 1.5$ V \pm 0.1 V, $T_A = -40^\circ\text{C}$ to 85°C

V_{DD}	Power Supply Voltage		1.4	1.5	1.6	V
I_{DDQ}	Quiescent Power Supply Current	Inputs Open, Outputs Unloaded			1	mA

LVC MOS DC CHARACTERISTICS, $V_{DD} = 3.3$ V \pm 5%, $T_A = -40^\circ\text{C}$ to 85°C

V_{IH}	Input High Voltage		$0.65 * V_{DD}$		3.6	V
V_{IL}	Input Low Voltage		-0.3		$0.35 * V_{DD}$	V
I_{IH}	Input High Current	CLK_IN	$V_{DD} = V_{IN} = 3.465$ V		165	μA
		OE	$V_{DD} = V_{IN} = 3.465$ V		5	μA
I_{IL}	Input Low Current	CLK_IN	$V_{DD} = 3.465$ V, $V_{IN} = 0$ V	-5		μA
		OE	$V_{DD} = 3.465$ V, $V_{IN} = 0$ V	-150		μA
V_{OH}	Output High Voltage	Q[4:1]	$I_{OH} = -12$ mA	2.6		V
V_{OL}	Output Low Voltage	Q[4:1]	$I_{OL} = 12$ mA		0.5	V

LVC MOS DC CHARACTERISTICS, $V_{DD} = 2.5$ V \pm 5%, $T_A = -40^\circ\text{C}$ to 85°C

V_{IH}	Input High Voltage		$0.65 * V_{DD}$		3.6	V
V_{IL}	Input Low Voltage		-0.3		$0.35 * V_{DD}$	V
I_{IH}	Input High Current	CLK_IN	$V_{DD} = V_{IN} = 2.625$ V		165	μA
		OE	$V_{DD} = V_{IN} = 2.625$ V		5	μA
I_{IL}	Input Low Current	CLK_IN	$V_{DD} = 2.625$ V, $V_{IN} = 0$ V	-5		μA
		OE	$V_{DD} = 2.625$ V, $V_{IN} = 0$ V	-150		μA

NB3U1548C

Table 5. DC ELECTRICAL CHARACTERISTICS

Symbol	Parameter	Test Conditions	Min	Typ	Max	Units
LVC MOS DC CHARACTERISTICS, $V_{DD} = 2.5\text{ V} \pm 5\%$, $T_A = -40^\circ\text{C}$ to 85°C						
V_{OH}	Output High Voltage	Q[4:1]	$I_{OH} = -12\text{ mA}$	1.8		V
V_{OL}	Output Low Voltage	Q[4:1]	$I_{OL} = 12\text{ mA}$		0.5	V
LVC MOS DC CHARACTERISTICS, $V_{DD} = 1.8\text{ V} \pm 0.15\text{ V}$, $T_A = -40^\circ\text{C}$ to 85°C						
V_{IH}	Input High Voltage			$0.65 * V_{DD}$	3.6	V
V_{IL}	Input Low Voltage			-0.3	$0.35 * V_{DD}$	V
I_{IH}	Input High Current	CLK_IN	$V_{DD} = V_{IN} = 1.95\text{ V}$		165	μA
		OE			5	μA
I_{IL}	Input Low Current	CLK_IN	$V_{DD} = 1.95\text{ V}, V_{IN} = 0\text{ V}$	-5		μA
		OE	$V_{DD} = 1.95\text{ V}, V_{IN} = 0\text{ V}$	-150		μA
V_{OH}	Output High Voltage	Q[4:1]	$I_{OH} = -6\text{ mA}$	$V_{DD} - 0.45$		V
V_{OL}	Output Low Voltage	Q[4:1]	$I_{OL} = 6\text{ mA}$		0.45	V
LVC MOS DC CHARACTERISTICS, $V_{DD} = 1.5\text{ V} \pm 0.1\text{ V}$, $T_A = -40^\circ\text{C}$ to 85°C						
V_{IH}	Input High Voltage			$0.65 * V_{DD}$	3.6	V
V_{IL}	Input Low Voltage			-0.3	$0.35 * V_{DD}$	V
I_{IH}	Input High Current	CLK_IN	$V_{DD} = V_{IN} = 1.6\text{ V}$		165	μA
		OE	$V_{DD} = V_{IN} = 1.6\text{ V}$		5	μA
I_{IL}	Input Low Current	CLK_IN	$V_{DD} = 1.6\text{ V}, V_{IN} = 0\text{ V}$	-5		μA
		OE	$V_{DD} = 1.6\text{ V}, V_{IN} = 0\text{ V}$	-150		μA
V_{OH}	Output High Voltage	Q[4:1]	$I_{OH} = -4\text{ mA}$	$0.75 * V_{DD}$		V
V_{OL}	Output Low Voltage	Q[4:1]	$I_{OL} = 4\text{ mA}$		$0.25 * V_{DD}$	V

Product parametric performance is indicated in the Electrical Characteristics for the listed test conditions, unless otherwise noted. Product performance may not be indicated by the Electrical Characteristics if operated under different conditions.

NB3U1548C

Table 6. AC ELECTRICAL CHARACTERISTICS

Symbol	Parameter	Test Conditions	Min	Typ	Max	Units
AC CHARACTERISTICS, $V_{DD} = 3.3\text{ V} \pm 5\%$, $T_A = -40^\circ\text{C}$ to 85°C						
f_{OUT}	Output Frequency				160	MHz
t_{PLH}	Propagation Delay (low to high transition); (Notes 4, 8)		0.7		2.1	ns
t_{PHL}	Propagation Delay (high to low transition); (Notes 4, 8)		0.7		2.1	ns
t_{PLZ} , t_{PHZ}	Disable Time, (active to high-impedance)				10	ns
t_{PZL} , t_{PZH}	Enable Time, (high-impedance to active)				10	ns
$tsk(o)$	Output Skew; (Notes 5, 6)				250	ps
$tsk(pp)$	Part-to-Part Skew; (Notes 5, 7)				800	ps
t_{jit}	Buffer Additive Phase Jitter, RMS	25 MHz, Integration Range: 12 kHz – 5 MHz		0.094		ps
t_R / t_F	Output Rise/Fall Time	10% to 90%	0.33		1.2	ns
odc	Output Duty Cycle		48		53	%

AC CHARACTERISTICS, $V_{DD} = 2.5\text{ V} \pm 5\%$, $T_A = -40^\circ\text{C}$ to 85°C						
f_{OUT}	Output Frequency				160	MHz
t_{PLH}	Propagation Delay (low to high transition); (Notes 4, 8)		0.8		2.0	ns
t_{PHL}	Propagation Delay (high to low transition); (Notes 4, 8)		0.8		2.0	ns
t_{PLZ} , t_{PHZ}	Disable Time (active to high-impedance)				10	ns
t_{PZL} , t_{PZH}	Enable Time (high-impedance to active)				10	ns
$tsk(o)$	Output Skew; (Notes 5, 6)				250	ps
$tsk(pp)$	Part-to-Part Skew; (Notes 5, 7)				800	ps
t_{jit}	Buffer Additive Phase Jitter, RMS	25 MHz, Integration Range: 12 kHz – 5 MHz		0.076		ps
t_R / t_F	Output Rise/Fall Time	10% to 90%	0.33		1.2	ns
odc	Output Duty Cycle		45		53	%

AC CHARACTERISTICS, $V_{DD} = 1.8\text{ V} \pm 0.15\text{ V}$, $T_A = -40^\circ\text{C}$ to 85°C						
f_{OUT}	Output Frequency				160	MHz
t_{PLH}	Propagation Delay (low to high transition); (Notes 4, 8)		1.1		2.8	ns
t_{PHL}	Propagation Delay (high to low transition); (Notes 4, 8)		1.1		2.8	ns
t_{PLZ} , t_{PHZ}	Disable Time (active to high-impedance)				10	ns
t_{PZL} , t_{PZH}	Enable Time (high-impedance to active)				10	ns
$tsk(o)$	Output Skew; (Notes 5, 6)				250	ps
$tsk(pp)$	Part-to-Part Skew; (Notes 5, 7)				800	ps
t_{jit}	Buffer Additive Phase Jitter, RMS	25 MHz, Integration Range: 12 kHz – 5MHz		0.193		ps

NOTE: Device will meet the specifications after thermal equilibrium has been established when mounted in a test socket or printed circuit board with maintained transverse airflow greater than 500 lfm.

3. Characterized up to $F_{OUT} \leq 150\text{ MHz}$.
4. Measured from the $V_{DD}/2$ of the input to $V_{DD}/2$ of the output.
5. This parameter is defined in accordance with JEDEC Standard 65.
6. Defined as skew between outputs at the same supply voltage and with equal load conditions. Measured at $V_{DD}/2$.
7. Defined as skew between outputs on different devices operating at the same supply voltage, same temperature, same frequency and with equal load conditions. Using the same type of inputs on each device, the outputs are measured at $V_{DD}/2$.
8. With rail to rail input clock.

NB3U1548C

Table 6. AC ELECTRICAL CHARACTERISTICS

Symbol	Parameter	Test Conditions	Min	Typ	Max	Units
AC CHARACTERISTICS, $V_{DD} = 1.8\text{ V} \pm 0.15\text{ V}$, $T_A = -40^\circ\text{C}$ to 85°C						
t_R / t_F	Output Rise/Fall Time	0.63 V to 1.17 V	0.11		0.6	ns
odc	Output Duty Cycle		47		53	%
AC CHARACTERISTICS, $V_{DD} = 1.5\text{ V} \pm 0.1\text{ V}$, $T_A = -40^\circ\text{C}$ to 85°C						
f_{OUT}	Output Frequency				160	MHz
t_{PLH}	Propagation Delay (low to high transition); (Notes 4, 8)		1.5		3.5	ns
t_{PHL}	Propagation Delay (high to low transition); (Notes 4, 8)		1.5		3.5	ns
t_{PLZ} , t_{PHZ}	Disable Time (active to high-impedance)				10	ns
t_{PZL} , t_{PZH}	Enable Time (high-impedance to active)				10	ns
tsk(o)	Output Skew; (Notes 5, 6)				250	ps
tsk(pp)	Part-to-Part Skew; (Notes 5, 7)				800	ps
tjit	Buffer Additive Phase Jitter, RMS	25 MHz, Integration Range: 12 kHz – 5 MHz		0.266		ps
t_R / t_F	Output Rise/Fall Time	0.525 V to 0.975 V	0.11		0.6	ns
odc	Output Duty Cycle		47		53	%

NOTE: Device will meet the specifications after thermal equilibrium has been established when mounted in a test socket or printed circuit board with maintained transverse airflow greater than 500 lfpm.

3. Characterized up to $F_{OUT} \leq 150\text{ MHz}$.
4. Measured from the $V_{DD}/2$ of the input to $V_{DD}/2$ of the output.
5. This parameter is defined in accordance with JEDEC Standard 65.
6. Defined as skew between outputs at the same supply voltage and with equal load conditions. Measured at $V_{DD}/2$.
7. Defined as skew between outputs on different devices operating at the same supply voltage, same temperature, same frequency and with equal load conditions. Using the same type of inputs on each device, the outputs are measured at $V_{DD}/2$.
8. With rail to rail input clock.

Parameter Measurement Information

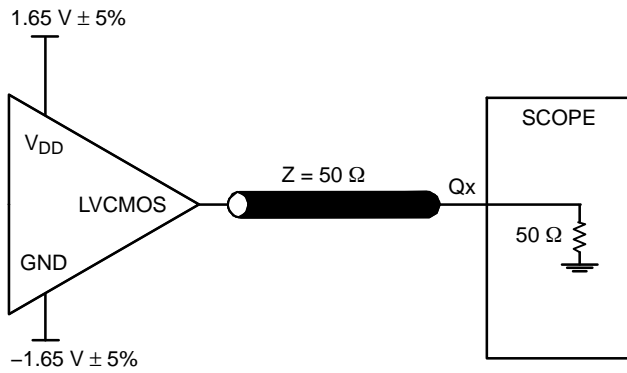

Figure 3. 3.3 V Output Load AC Test Circuit

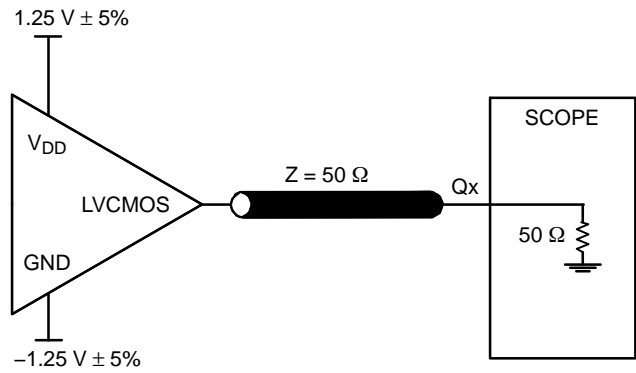

Figure 4. 2.5 V Output Load AC Test Circuit

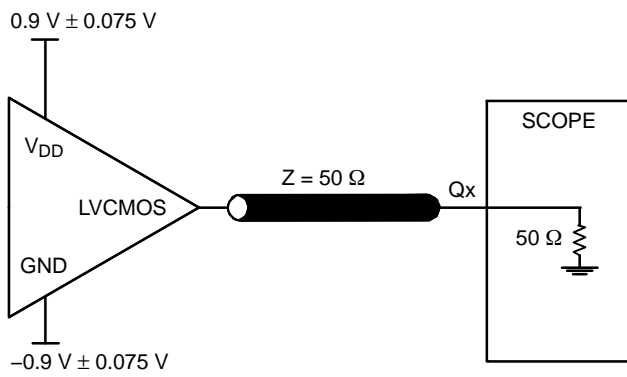

Figure 5. 1.8 V Output Load AC Test Circuit

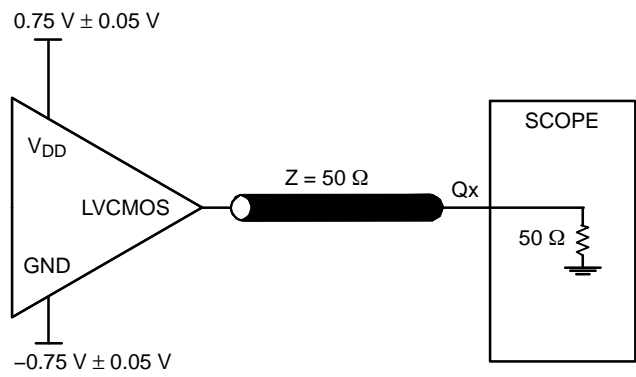

Figure 6. 1.5 V Output Load AC Test Circuit

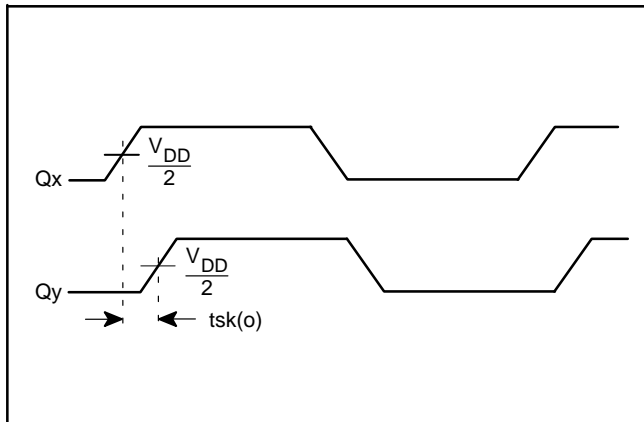

Figure 7. Output Skew

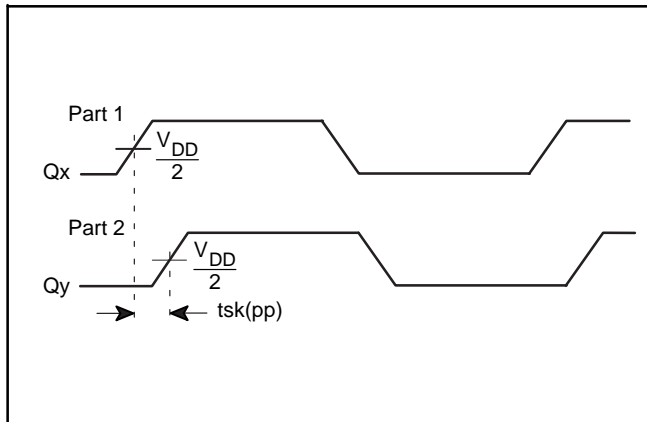

Figure 8. Part-to-Part Skew

Parameter Measurement Information, (continued)

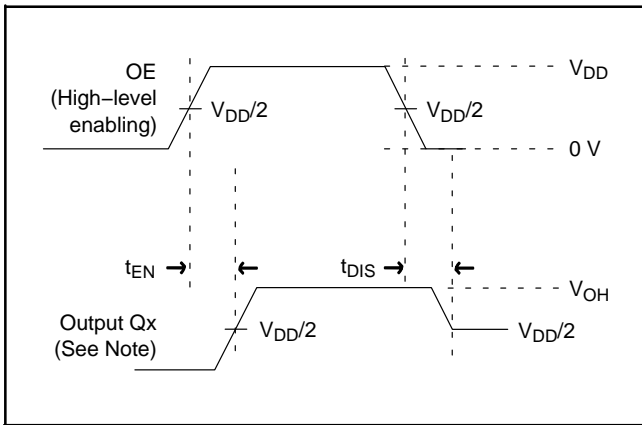

Figure 9. Output Enable/Disable Time

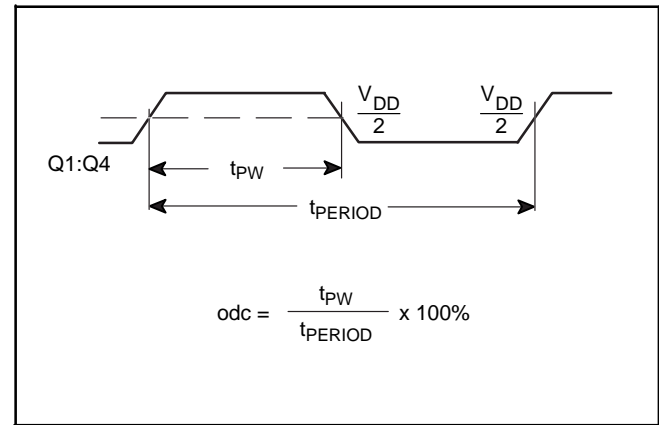

Figure 10. Output Duty Cycle/Pulse Width/Period

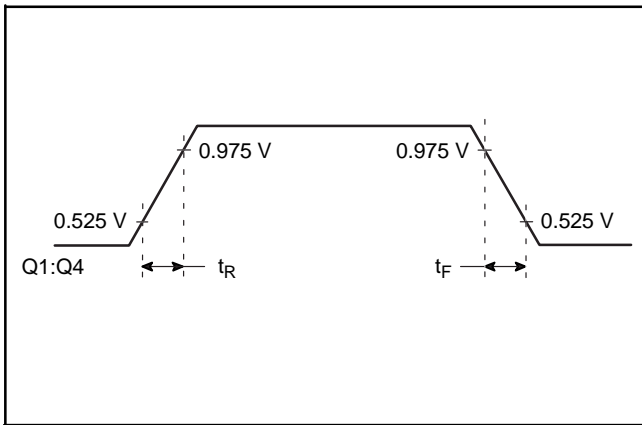

Figure 11. 1.5 V Output Rise/Fall Time

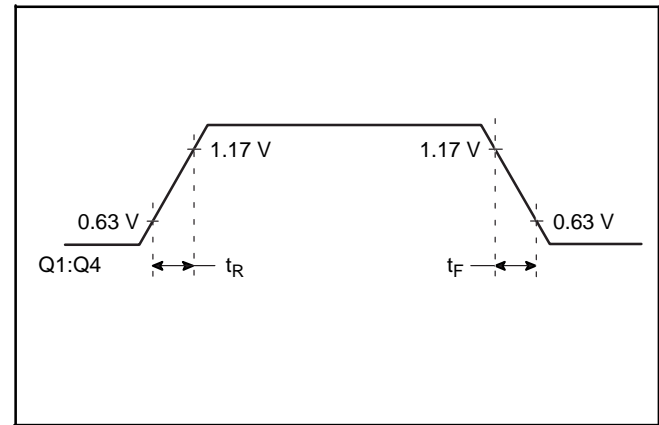

Figure 12. 1.8 V Output Rise/Fall Time

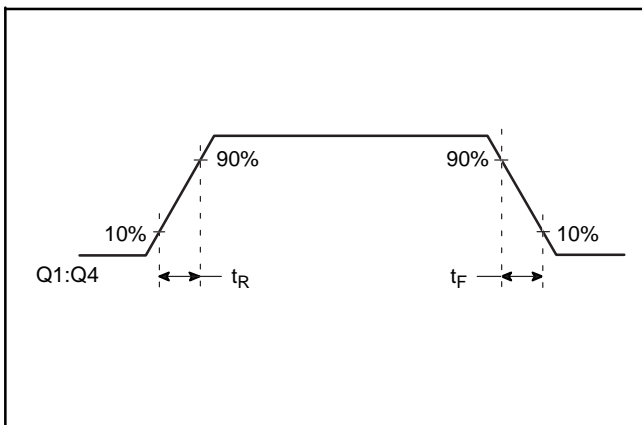

Figure 13. 2.5 V and 3.3 V Output Rise/Fall Time

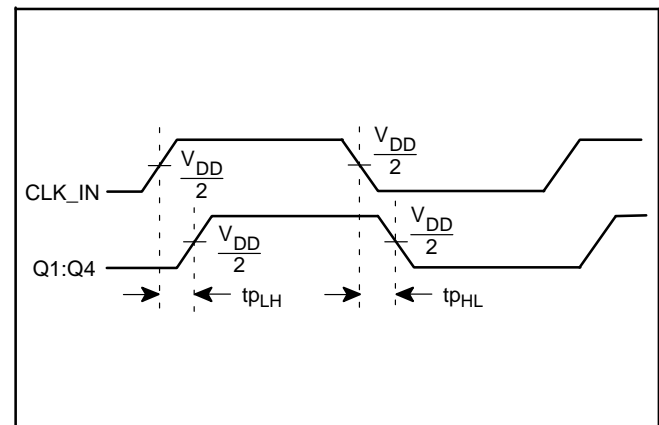

Figure 14. Propagation Delay

NB3U1548C

Table 7. THERMAL RESISTANCE θ_{JA}

θ_{JA} by Velocity			
FOR 8 LEAD SOIC, FORCED CONVECTION			
Meters per Second	0	1	2.5
Multi-Layer PCB, JEDEC Standard Test Boards	102.5°C/W	93.5°C/W	88.6°C/W
FOR 8 LEAD TSSOP, FORCED CONVECTION			
Meters per Second	0	1	2.5
Multi-Layer PCB, JEDEC Standard Test Boards	151.2°C/W	145.9°C/W	143.3°C/W
θ_{JA} by Velocity			

Table 8. ORDERING INFORMATION

Device	Package	Shipping [†]
NB3U1548CDG	SOIC-8 (Pb-Free)	96 Units / Tube
NB3U1548CDR2G	SOIC-8 (Pb-Free)	3000 / Tape & Reel
NB3U1548CDTR2G	TSSOP-8 (Pb-Free)	2500 / Tape & Reel

[†]For information on tape and reel specifications, including part orientation and tape sizes, please refer to our Tape and Reel Packaging Specification Brochure, BRD8011/D.

NB3U1548C

PACKAGE DIMENSIONS

SOIC-8 NB
CASE 751-07
ISSUE AK

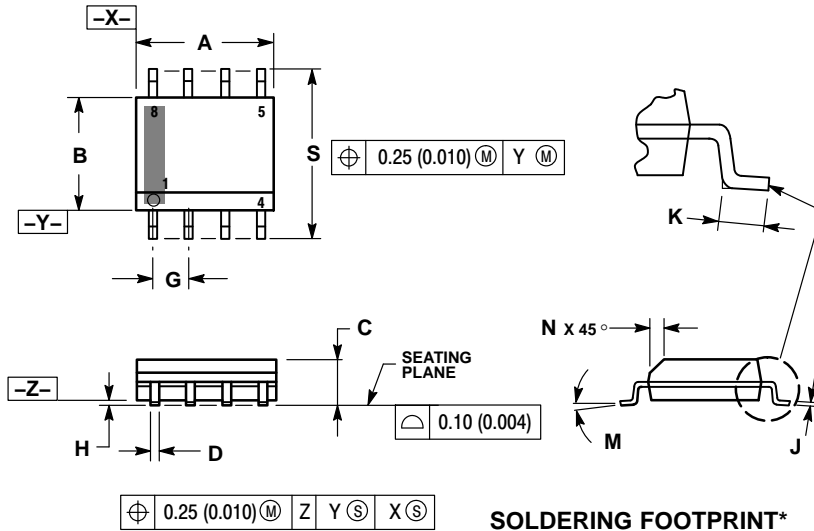

NOTES:

1. DIMENSIONING AND TOLERANCING PER ANSI Y14.5M, 1982.
2. CONTROLLING DIMENSION: MILLIMETER.
3. DIMENSION A AND B DO NOT INCLUDE MOLD PROTRUSION.
4. MAXIMUM MOLD PROTRUSION 0.15 (0.006) PER SIDE.
5. DIMENSION D DOES NOT INCLUDE DAMBAR PROTRUSION. ALLOWABLE DAMBAR PROTRUSION SHALL BE 0.127 (0.005) TOTAL IN EXCESS OF THE D DIMENSION AT MAXIMUM MATERIAL CONDITION.
6. 751-01 THRU 751-06 ARE OBSOLETE. NEW STANDARD IS 751-07.

DIM	MILLIMETERS		INCHES	
	MIN	MAX	MIN	MAX
A	4.80	5.00	0.189	0.197
B	3.80	4.00	0.150	0.157
C	1.35	1.75	0.053	0.069
D	0.33	0.51	0.013	0.020
G	1.27 BSC		0.050 BSC	
H	0.10	0.25	0.004	0.010
J	0.19	0.25	0.007	0.010
K	0.40	1.27	0.016	0.050
M	0°	8°	0°	8°
N	0.25	0.50	0.010	0.020
S	5.80	6.20	0.228	0.244

SOLDERING FOOTPRINT*

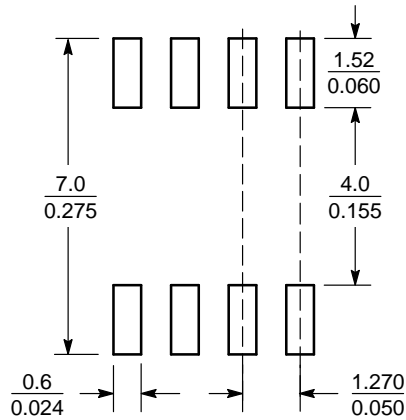

SCALE 6:1 $\left(\frac{\text{mm}}{\text{inches}}\right)$

*For additional information on our Pb-Free strategy and soldering details, please download the ON Semiconductor Soldering and Mounting Techniques Reference Manual, SOLDERRM/D.

NB3U1548C

PACKAGE DIMENSIONS

TSSOP-8
CASE 948S
ISSUE C

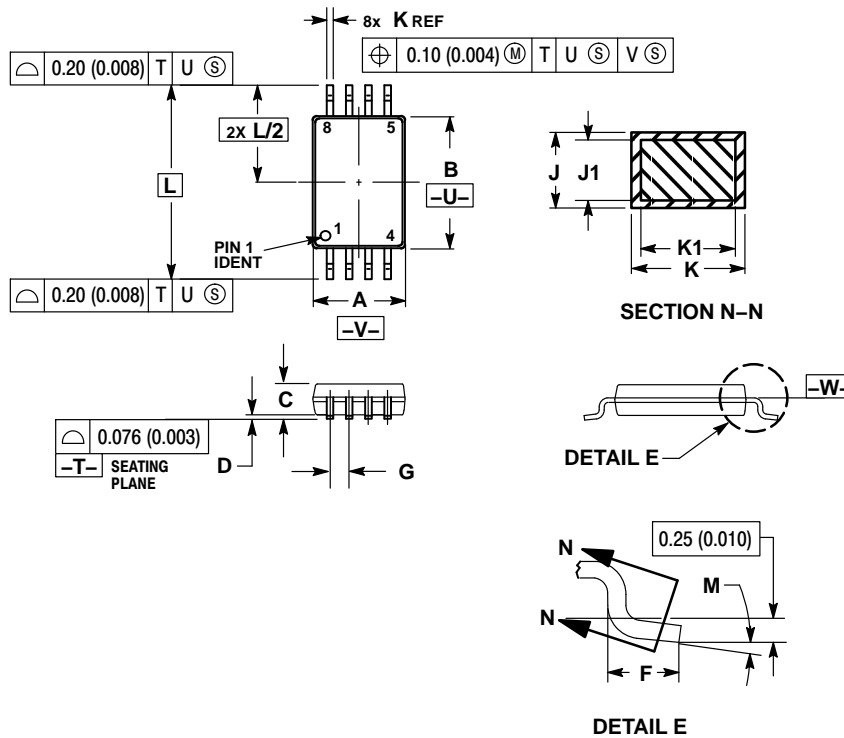

NOTES:

1. DIMENSIONING AND TOLERANCING PER ANSI Y14.5M, 1982.
2. CONTROLLING DIMENSION: MILLIMETER.
3. DIMENSION A DOES NOT INCLUDE MOLD FLASH, PROTRUSIONS OR GATE BURRS. MOLD FLASH OR GATE BURRS SHALL NOT EXCEED 0.15 (0.006) PER SIDE.
4. DIMENSION B DOES NOT INCLUDE INTERLEAD FLASH OR PROTRUSION. INTERLEAD FLASH OR PROTRUSION SHALL NOT EXCEED 0.25 (0.010) PER SIDE.
5. TERMINAL NUMBERS ARE SHOWN FOR REFERENCE ONLY.
6. DIMENSION A AND B ARE TO BE DETERMINED AT DATUM PLANE -W-.

DIM	MILLIMETERS		INCHES	
	MIN	MAX	MIN	MAX
A	2.90	3.10	0.114	0.122
B	4.30	4.50	0.169	0.177
C	---	1.10	---	0.043
D	0.05	0.15	0.002	0.006
F	0.50	0.70	0.020	0.028
G	0.65 BSC		0.026 BSC	
J	0.09	0.20	0.004	0.008
J1	0.09	0.16	0.004	0.006
K	0.19	0.30	0.007	0.012
K1	0.19	0.25	0.007	0.010
L	6.40 BSC		0.252 BSC	
M	0°	8°	0°	8°

ON Semiconductor and are trademarks of Semiconductor Components Industries, LLC dba ON Semiconductor or its subsidiaries in the United States and/or other countries. ON Semiconductor owns the rights to a number of patents, trademarks, copyrights, trade secrets, and other intellectual property. A listing of ON Semiconductor's product/patent coverage may be accessed at www.onsemi.com/site/pdf/Patent-Marking.pdf. ON Semiconductor reserves the right to make changes without further notice to any products herein. ON Semiconductor makes no warranty, representation or guarantee regarding the suitability of its products for any particular purpose, nor does ON Semiconductor assume any liability arising out of the application or use of any product or circuit, and specifically disclaims any and all liability, including without limitation special, consequential or incidental damages. Buyer is responsible for its products and applications using ON Semiconductor products, including compliance with all laws, regulations and safety requirements or standards, regardless of any support or applications information provided by ON Semiconductor. "Typical" parameters which may be provided in ON Semiconductor data sheets and/or specifications can and do vary in different applications and actual performance may vary over time. All operating parameters, including "Typicals" must be validated for each customer application by customer's technical experts. ON Semiconductor does not convey any license under its patent rights nor the rights of others. ON Semiconductor products are not designed, intended, or authorized for use as a critical component in life support systems or any FDA Class 3 medical devices or medical devices with a same or similar classification in a foreign jurisdiction or any devices intended for implantation in the human body. Should Buyer purchase or use ON Semiconductor products for any such unintended or unauthorized application, Buyer shall indemnify and hold ON Semiconductor and its officers, employees, subsidiaries, affiliates, and distributors harmless against all claims, costs, damages, and expenses, and reasonable attorney fees arising out of, directly or indirectly, any claim of personal injury or death associated with such unintended or unauthorized use, even if such claim alleges that ON Semiconductor was negligent regarding the design or manufacture of the part. ON Semiconductor is an Equal Opportunity/Affirmative Action Employer. This literature is subject to all applicable copyright laws and is not for resale in any manner.

PUBLICATION ORDERING INFORMATION

LITERATURE FULFILLMENT:

Literature Distribution Center for ON Semiconductor
19521 E. 32nd Pkwy, Aurora, Colorado 80011 USA
Phone: 303-675-2175 or 800-344-3860 Toll Free USA/Canada
Fax: 303-675-2176 or 800-344-3867 Toll Free USA/Canada
Email: orderlit@onsemi.com

N. American Technical Support: 800-282-9855 Toll Free
USA/Canada
Europe, Middle East and Africa Technical Support:
Phone: 421 33 790 2910
Japan Customer Focus Center
Phone: 81-3-5817-1050

ON Semiconductor Website: www.onsemi.com

Order Literature: <http://www.onsemi.com/orderlit>

For additional information, please contact your local Sales Representative



Компания «ЭлектроПласт» предлагает заключение долгосрочных отношений при поставках импортных электронных компонентов на взаимовыгодных условиях!

Наши преимущества:

- Оперативные поставки широкого спектра электронных компонентов отечественного и импортного производства напрямую от производителей и с крупнейших мировых складов;
- Поставка более 17-ти миллионов наименований электронных компонентов;
- Поставка сложных, дефицитных, либо снятых с производства позиций;
- Оперативные сроки поставки под заказ (от 5 рабочих дней);
- Экспресс доставка в любую точку России;
- Техническая поддержка проекта, помощь в подборе аналогов, поставка прототипов;
- Система менеджмента качества сертифицирована по Международному стандарту ISO 9001;
- Лицензия ФСБ на осуществление работ с использованием сведений, составляющих государственную тайну;
- Поставка специализированных компонентов (Xilinx, Altera, Analog Devices, Intersil, Interpoint, Microsemi, Aeroflex, Peregrine, Syfer, Eurofarad, Texas Instrument, Miteq, Cobham, E2V, MA-COM, Hittite, Mini-Circuits, General Dynamics и др.);

Помимо этого, одним из направлений компании «ЭлектроПласт» является направление «Источники питания». Мы предлагаем Вам помощь Конструкторского отдела:

- Подбор оптимального решения, техническое обоснование при выборе компонента;
- Подбор аналогов;
- Консультации по применению компонента;
- Поставка образцов и прототипов;
- Техническая поддержка проекта;
- Защита от снятия компонента с производства.



Как с нами связаться

Телефон: 8 (812) 309 58 32 (многоканальный)

Факс: 8 (812) 320-02-42

Электронная почта: org@eplast1.ru

Адрес: 198099, г. Санкт-Петербург, ул. Калинина, дом 2, корпус 4, литера А.