

NAIS

PRECISION SEMICONDUCTOR PRESSURE SENSOR

PF PRESSURE SENSOR

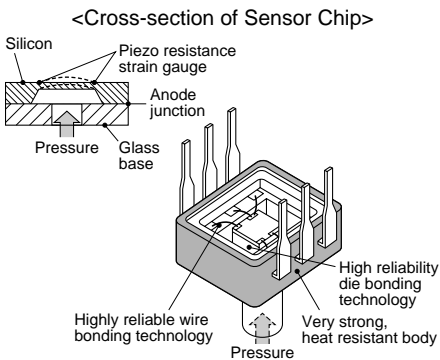
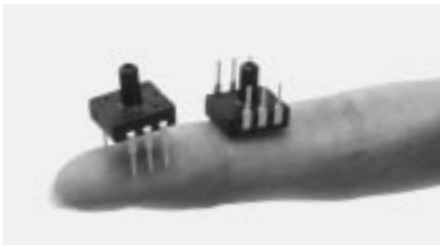

- **A wide range of rated pressure, including a minute pressure**
There are 10 types of sensors covering a wide range of rated pressure from a minute pressure between 4.9 kPa {0.05 kgf/cm²}, to a maximum pressure of 980.7 kPa {10 kgf/cm²}.
- **Realization of highly accurate, linear characteristics**
This sensor employs a semiconductor strain gauge method, ensuring accurate and linear detection characteristics. It also has excellent repeatability of pressure characteristics.
- **Impressive line-up of models**
 - Taking their place alongside the standard 5kΩ bridge resistance models are those with a 3.3kΩ resistance which is optimally suited to 5V drive circuits.
 - Economy model (no glass base) gives outstanding value for consumer appliances
40 kPa (0.4 kgf/cm²) and 49 kPa (0.5 kgf/cm²) units are also available.

Example of pressure characteristics
(when the rated pressure is between 98.1 kPa {1.0 kgf/cm²})
Drive current: 1.5 mA rated current; ambient temperature: 25°C 77°F

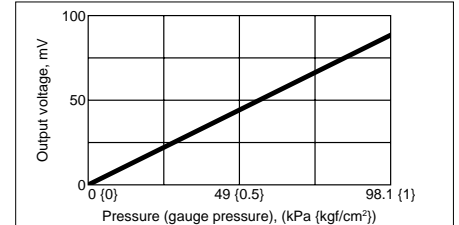

TYPICAL APPLICATIONS

- Medical equipment: Electronic hemodynamometer
- Home appliance: Vacuum cleaner
- Gas equipment: Microprocessor gas meter, gas leakage detector
- Industrial equipment: Absorption device, etc.

ORDERING INFORMATION

Ex. ADP 1

Part No.	Terminal profile and direction	Rated pressure	Type	Bridge resistance
ADP1: PF pressure sensor	1: DIP terminal: Direction opposite the pressure inlet direction 2: DIP terminal: Pressure inlet direction 	0: 4.9 kPa {approx. 0.05 kgf/cm ² } 1: 14.7 kPa {approx. 0.15 kgf/cm ² } 2: 34.3 kPa {approx. 0.35 kgf/cm ² } 3: 49.0 kPa {approx. 0.5 kgf/cm ² } 4: 98.1 kPa {approx. 1.0 kgf/cm ² } 5: 196.1 kPa {approx. 2.0 kgf/cm ² } 6: 343.2 kPa {approx. 3.5 kgf/cm ² } 7: 490.3 kPa {approx. 5.0 kgf/cm ² } 8: 833.6 kPa {approx. 8.5 kgf/cm ² } 9: 980.7 kPa {approx. 10.0 kgf/cm ² } A: 40.0 kPa {approx. 0.4 kgf/cm ² }	1: Standard type (With glass base) 2: Economy type (Without glass base)	Nil : 5.0kΩ 3 : 3.3kΩ

Pressure	Bridge resistance		5.0kΩ		3.3kΩ	
	Terminal		DIP terminal: Direction opposite the pressure inlet direction	DIP terminal: Pressure inlet direction	DIP terminal: Direction opposite the pressure inlet direction	DIP terminal: Pressure inlet direction
Standard type (With glass base)	4.9kPa	approx. 0.05kgf/cm ²	ADP1101	ADP1201	—	—
	14.7kPa	approx. 0.15kgf/cm ²	ADP1111	ADP1211	—	—
	34.3kPa	approx. 0.35kgf/cm ²	ADP1121	ADP1221	—	—
	49.0kPa	approx. 0.5kgf/cm ²	ADP1131	ADP1231	—	—
	98.1kPa	approx. 1.0kgf/cm ²	ADP1141	ADP1241	—	—
	196.1kPa	approx. 2.0kgf/cm ²	ADP1151	ADP1251	—	—
	343.2kPa	approx. 3.5kgf/cm ²	ADP1161	ADP1261	—	—
	490.3kPa	approx. 5.0kgf/cm ²	ADP1171	ADP1271	—	—
	833.6kPa	approx. 8.5kgf/cm ²	ADP1181	ADP1281	—	—
	980.7kPa	approx. 10.0kgf/cm ²	ADP1191	ADP1291	—	—
Economy type (Without glass base)	40.0kPa	approx. 0.4kgf/cm ²	—	—	ADP11A23	ADP12A23
	49.0kPa	approx. 0.5kgf/cm ²	ADP1132	ADP1232	—	—

PF (ADP1)

SPECIFICATIONS

Type		Standard type (With glass base)											Economy type (Without glass base)			
Type of pressure		Gauge pressure														
Pressure medium		Air (For other medium, please consult us.)														
Rated pressure	Unit: kPa	4.9	14.7	34.3	49.0	98.1	196.1	343.2	490.3	833.6	980.7	40.0	49.0			
	Unit: kgf/cm ² (approx.)	0.05	0.15	0.35	0.5	1.0	2.0	3.5	5.0	8.5	10.0	0.4	0.5			
Max. applied pressure		Twice the rated pressure										1.5 times the rated pressure	Twice the rated pressure			
Bridge resistance		5000±1000 Ω											3300±600 Ω	5000±1000 Ω		
Ambient temperature		-20 to 100°C -4 to 212°F (no freezing or condensation)														
Storage temperature		-40 to 120°C -40 to 248°F (no freezing or condensation)											-20 to 70°C -4 to 158°F	-40 to 120°C -70 to 248°F		
Temperature compensation range		0 to 50°C 32 to 122°F											5 to 45°C 41 to 113°F	0 to 50°C 32 to 122°F		
Drive current (constant current)		1.5 mA DC														
Output span voltage		40±20 mV	100±40 mV											43.5±22.5 mV	85±45 mV	
Offset voltage		±20 mV													±15 mV	±25 mV
Linearity		±0.7%FS	±0.5%FS	±0.3%FS					±0.5%FS	±0.6%FS		±0.3%FS				
Pressure hysteresis		±0.6%FS	±0.4%FS	±0.2%FS					±0.4%FS		±0.7%FS					
Offset voltage-temperature characteristics (0 to 50°C 32 to 122°F)		±15%FS	±5.0%FS										±10%FS	±8%FS		
Sensitivity-temperature characteristics (0 to 50°C 32 to 122°F)		±10%FS	±2.5%FS										±1.3%FS	±2.5%FS		

Notes) 1. Unless otherwise specified, measurements were taken with a drive current of 1.5 mA ±0.01 mA at a temperature of 25°C 77°F and humidity ranging from 25% to 85%.
 2. Please consult us if a pressure medium other than air is to be used.
 3. This is the regulation which applies within the compensation temperature range.
 4. Please consult us if the intended use involves a negative pressure.

DATA

1. Characteristics data

1-<1> Output characteristics

ADP1141
 Drive current: 1.5 mA; temperature: 25°C 77°F

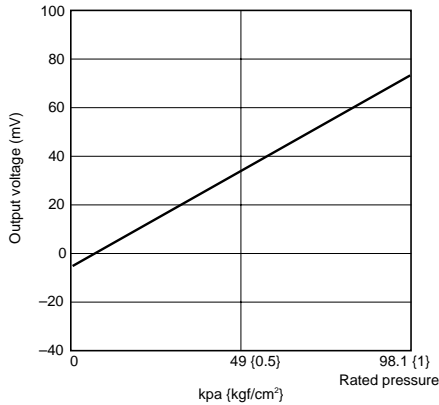

1-<2> Offset voltage – temperature characteristics

ADP1141
 Drive current: 1.5 mA; rating ±5%FS

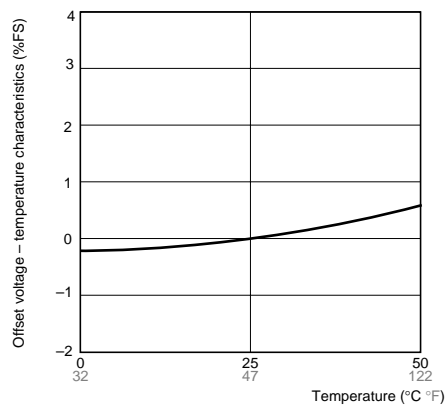

1-<3> Sensitivity – temperature characteristics (%FS)

ADP1141
 Drive current: 1.5 mA; rating ±2.5%FS

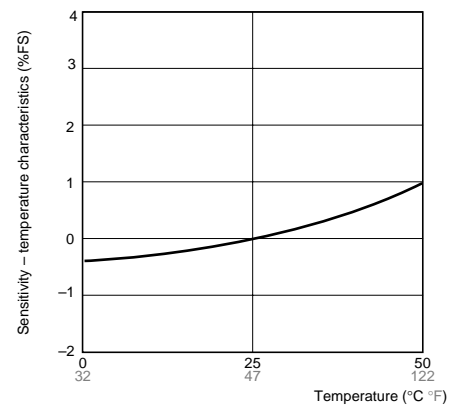

2. Pressure cycle range (0 to rated pressure)

Tested sample: ADP1131, temperature: 25°C 77°F

2-<1> Offset voltage range

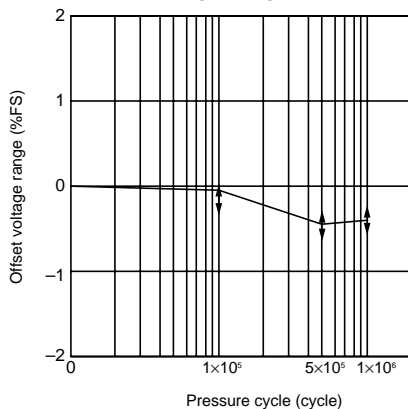

2-<2> Output span voltage range

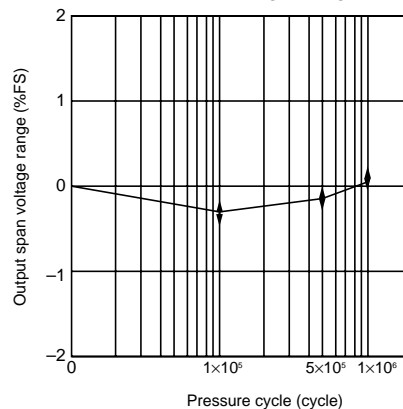

Even after testing for 1 million times, the variations in the offset voltage and output span voltage are minimal.

3. Evaluation test

Tested item	Tested condition	Result
Environmental characteristics	Storage at high temperature Temperature: Left in a 120°C 248°F constant temperature bath Time: 1,000 hrs.	Passed
	Storage at low temperature Temperature: Left in a -40°C -40°F constant temperature bath Time: 1,000 hrs.	Passed
	Humidity Temperature/humidity: Left at 40°C 104°F, 90% RH Time: 1,000 hrs.	Passed
	Temperature cycle Temperature: -40°C to 120°C -40°F to 248°F 1 cycle: 30 min. Times of cycle: 100	Passed
Endurance characteristics	High temperature/high humidity operation Temperature/humidity: 40°C 104°F, 90% RH Operation times: 10 ⁶ , rated voltage applied	Passed
Mechanical characteristics	Vibration resistance Double amplitude: 1.5 mm .059 inch Vibration: 10 to 55 Hz Applied vibration direction: X, Y, Z 3 directions Times: 2 hrs each	Passed
	Dropping resistance Dropping height: 75 cm 29.528 inch Times: 2 times	Passed
	Terminal strength Pulling strength: 9.8 N {1 kgf}, 10 sec. Bending strength: 4.9 N {0.5 kgf}, left and right 90° 1 time	Passed
Soldering Resistance	Soldered in DIP soldering bath Temperature: 230°C 446°F Time: 5 sec.	Passed
	Temperature Temperature: 260°C 500°F Time: 10 sec.	Passed

Note: For details other than listed above, please consult us.

DIMENSIONS

General tolerance: ±0.3 ±.012 mm inch

1. Terminal direction: Direction opposite the pressure inlet direction ADP11□□ (□)

2. Terminal direction: Pressure inlet direction ADP12□□ (□)

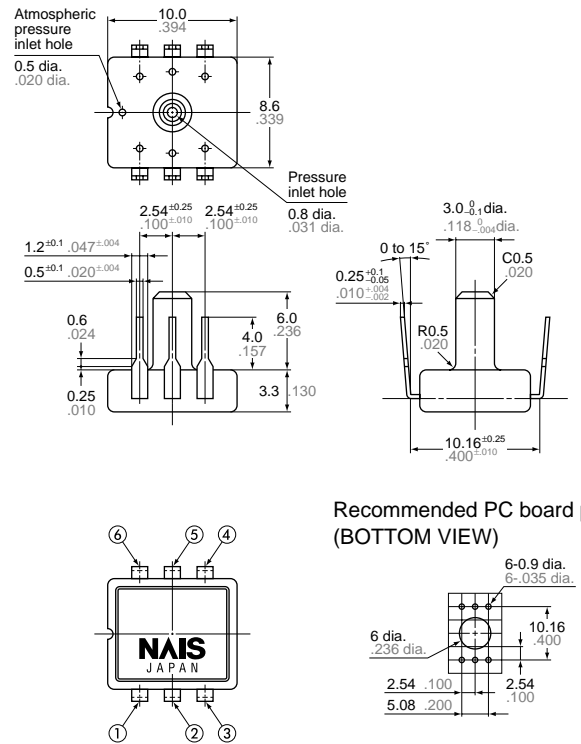
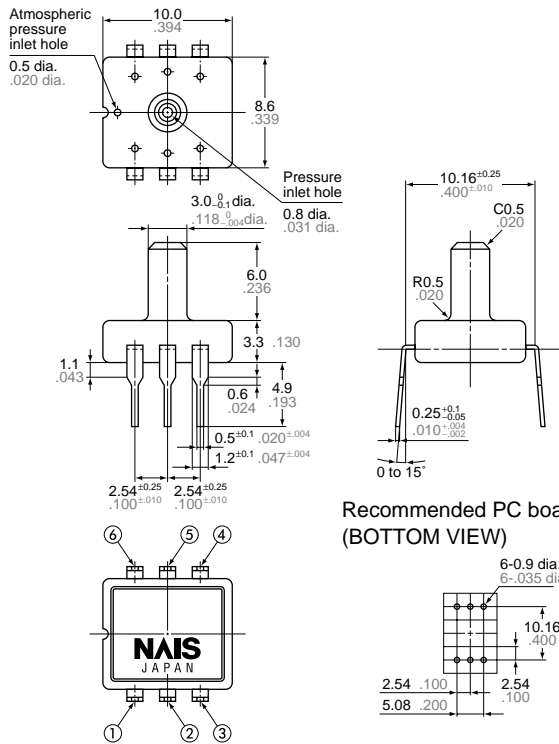

Recommended PC board pattern (BOTTOM VIEW)

Recommended PC board pattern (BOTTOM VIEW)

Tolerance: ±0.1 .004

Tolerance: ±0.1 .004

3. Terminal connection diagram

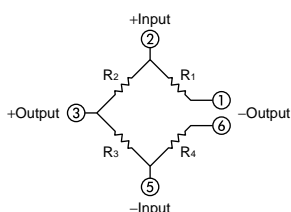

Terminal No.	Name
1	Output (-)
2	Power supply (+)
3	Output (+)
4	No connection
5	Power supply (-)
6	Output (-)

Note: Leave terminal 4 unconnected.

NOTES

1. Mounting

Use lands on the printed-circuit boards to which the sensor can be securely fixed.

2. Soldering

1) Due to its small size, the thermal capacity of the pressure sensor DIP type is low. Therefore, take steps to minimize the effects of external heat.

Dip soldering bath: Max. 260°C 500°F, 5 sec.

Soldering iron: 260 to 300°C 500 to 572°F (30W) within 5 sec.

2) Use a non-corrosive resin type of flux. Since the pressure sensor DIP type is exposed to the atmosphere, do not allow flux to enter inside.

3. Cleaning

1) Since the pressure sensor chip is exposed to the atmosphere, do not allow cleaning fluid to enter inside.

2) Avoid ultrasonic cleaning since this may cause breaks or disconnections in the wiring.

4. Environment

Consult with us before using or storing the pressure sensor chip in a place exposed to corrosive gases (such as the gases given off by organic solvents, sulfites, hydrogen sulfides, etc.) which will adversely affect the performance of the pressure sensor chip.

5. Quality check under actual loading conditions

1) To assure reliability, check the sensor under actual loading conditions. Avoid any situation that may adversely affect its performance.

2) As for test data, please contact us.

6. Other handling precautions

1) That using the wrong pressure range or mounting method may result in accidents.

2) Air can be used directly as a pressure medium. Consult with us before using a corrosive gas (such as a gas given off by an organic solvent, sulfite or hydrogen sulfide) as the pressure medium.

3) The pressure sensor chip is positioned inside the pressure inlet. Never poke wires or other foreign matter through the pressure inlet since they may damage the chip or block the inlet. Avoid use when the atmospheric pressure inlet is blocked.

4) Leave pin No. 4 unconnected since the pressure sensor chip may be damaged if a voltage is applied to this pin.

5) Use an operating pressure which is within the rated pressure range. Using a pressure beyond this range may cause damage.

6) Since this pressure sensor chip does not have a water-proof construction, consult with us if it is to be used in a location where it may be sprayed with water, etc.

7) Avoid using the pressure sensor chip in an environment where condensation may form. Furthermore, its output may fluctuate if any moisture adhering to it freezes.

8) The pressure sensor chip is constructed in such a way that its output will fluctuate when it is exposed to light.

Especially when pressure is to be applied by means of a transparent tube, take steps to prevent the pressure sensor chip from being exposed to light.

9) Avoid using the pressure sensor chip where it will be susceptible to ultrasonic or other high-frequency vibration.

10) Since static charge can damage the pressure sensor chip, bear in mind the following handling precautions.

- When storing the pressure sensor chips, use a conductive material to short the pins or wrap the entire chip in aluminum foil. Plastic containers should not be used to store or transport the chips since they readily become charged.

- When using the pressure sensor chips, all the charged articles on the bench surface and the work personnel should be grounded so that any ambient static will be safely discharged.

11) Due to the pressures involved, give due consideration to the securing of the pressure sensor DIP type and to the securing and selection of the inlet tube. Consult us if you have any queries.

APPLICATION CIRCUIT DIAGRAM (EXAMPLE)

The pressure sensor is designed to convert a voltage by means of constant current drive and then, if necessary, it amplifies the voltage for use. The circuit shown below is a typical example of a circuit in which the pressure sensor is used.

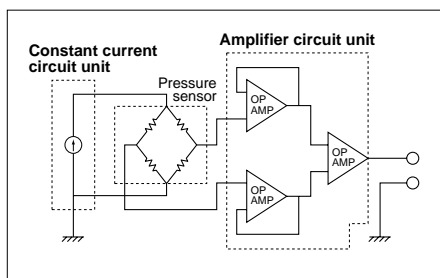

MOUNTING METHOD

The general method for transmitting air pressures differs depending on whether the pressure is low or high.

• Checkpoints for use

<1> Select a pressure inlet pipe which is sturdy enough to prevent pressure leaks.

<2> Fix the pressure inlet pipe securely so as to prevent pressure leaks.

<3> Do not block the pressure inlet pipe.

Methods of transmitting air pressures

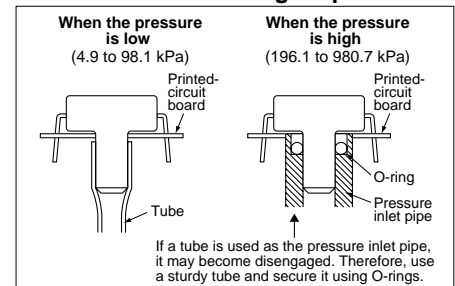



Компания «ЭлектроПласт» предлагает заключение долгосрочных отношений при поставках импортных электронных компонентов на взаимовыгодных условиях!

Наши преимущества:

- Оперативные поставки широкого спектра электронных компонентов отечественного и импортного производства напрямую от производителей и с крупнейших мировых складов;
- Поставка более 17-ти миллионов наименований электронных компонентов;
- Поставка сложных, дефицитных, либо снятых с производства позиций;
- Оперативные сроки поставки под заказ (от 5 рабочих дней);
- Экспресс доставка в любую точку России;
- Техническая поддержка проекта, помощь в подборе аналогов, поставка прототипов;
- Система менеджмента качества сертифицирована по Международному стандарту ISO 9001;
- Лицензия ФСБ на осуществление работ с использованием сведений, составляющих государственную тайну;
- Поставка специализированных компонентов (Xilinx, Altera, Analog Devices, Intersil, Interpoint, Microsemi, Aeroflex, Peregrine, Syfer, Eurofarad, Texas Instrument, Miteq, Cobham, E2V, MA-COM, Hittite, Mini-Circuits, General Dynamics и др.);

Помимо этого, одним из направлений компании «ЭлектроПласт» является направление «Источники питания». Мы предлагаем Вам помощь Конструкторского отдела:

- Подбор оптимального решения, техническое обоснование при выборе компонента;
- Подбор аналогов;
- Консультации по применению компонента;
- Поставка образцов и прототипов;
- Техническая поддержка проекта;
- Защита от снятия компонента с производства.



Как с нами связаться

Телефон: 8 (812) 309 58 32 (многоканальный)

Факс: 8 (812) 320-02-42

Электронная почта: org@eplast1.ru

Адрес: 198099, г. Санкт-Петербург, ул. Калинина, дом 2, корпус 4, литера А.