

SC16C654B/654DB

5 V, 3.3 V and 2.5 V quad UART, 5 Mbit/s (max.), with 64-byte FIFOs and infrared (IrDA) encoder/decoder

Rev. 02 — 20 June 2005

Product data sheet

1. General description

The SC16C654B/654DB is a Quad Universal Asynchronous Receiver and Transmitter (QUART) used for serial data communications. Its principal function is to convert parallel data into serial data and vice versa. The UART can handle serial data rates up to 5 Mbit/s. It comes with an Intel or Motorola interface.

The SC16C654B/654DB is pin compatible with the ST16C654 and TL16C754 and it will power-up to be functionally equivalent to the 16C454. Programming of control registers enables the added features of the SC16C654B/654DB. Some of these added features are the 64-byte receive and transmit FIFOs, automatic hardware or software flow control and infrared encoding/decoding. The selectable auto-flow control feature significantly reduces software overload and increases system efficiency while in FIFO mode by automatically controlling serial data flow using $\overline{\text{RTS}}$ output and $\overline{\text{CTS}}$ input signals. The SC16C654B/654DB also provides DMA mode data transfers through FIFO trigger levels and the $\overline{\text{TXRDY}}$ and $\overline{\text{RXRDY}}$ signals. ($\overline{\text{TXRDY}}$ and $\overline{\text{RXRDY}}$ signals are not available in the HVQFN48 package.) On-board status registers provide the user with error indications, operational status, and modem interface control. System interrupts may be tailored to meet user requirements. An internal loop-back capability allows on-board diagnostics.

The SC16C654B/654DB operates at 5 V, 3.3 V and 2.5 V, and the industrial temperature range, and is available in plastic PLCC68, LQFP64, HVQFN48 and LFBGA64 packages.

On the HVQFN48 package, only channel C has all the modem pins. Channel A and channel B have only $\overline{\text{RTS}}$ and $\overline{\text{CTS}}$ pins, and channel D does not have any modem pin.

2. Features

- 4 channel UART
- 5 V, 3.3 V and 2.5 V operation
- Industrial temperature range (−40 °C to +85 °C)
- SC16C654B is pin and software compatible with the industry-standard ST16C454/554, ST16C654, ST68C454/554, TL16C554
- SC16C654DB is pin and software compatible with ST16C654D, and software compatible with ST16C454/554, ST68C454/554, TL16C554
- Up to 5 Mbit/s data rate at 5 V and 3.3 V and 3 Mbit/s at 2.5 V
- 5 V tolerant inputs
- 64-byte transmit FIFO
- 64-byte receive FIFO with error flags
- Automatic software (Xon/Xoff)/hardware ($\overline{\text{RTS}}$ / $\overline{\text{CTS}}$) flow control
- Programmable Xon/Xoff characters

PHILIPS

- Software selectable baud rate generator
- Four selectable Receive and Transmit FIFO interrupt trigger levels
- Standard modem interface or infrared (IrDA) encoder/decoder interface
- Sleep mode
- Standard asynchronous error and framing bits (Start, Stop, and Parity Overrun Break)
- Transmit, Receive, Line Status, and Data Set interrupts independently controlled
- Fully programmable character formatting:
 - ◆ 5, 6, 7, or 8-bit characters
 - ◆ Even, Odd, or No Parity formats
 - ◆ 1, 1½, or 2-stop bit
 - ◆ Baud generation (DC to 5 Mbit/s)
- False start-bit detection
- Complete status reporting capabilities
- 3-state output TTL drive capabilities for bi-directional data bus and control bus
- Line break generation and detection
- Internal diagnostic capabilities:
 - ◆ Loop-back controls for communications link fault isolation
- Prioritized interrupt system controls
- Modem control functions ($\overline{\text{CTS}}$, $\overline{\text{RTS}}$, $\overline{\text{DSR}}$, $\overline{\text{DTR}}$, $\overline{\text{RI}}$, $\overline{\text{CD}}$).

3. Ordering information

Table 1: Ordering information

Type number	Package		
	Name	Description	Version
SC16C654BIA68	PLCC68	plastic leaded chip carrier; 68 leads	SOT188-2
SC16C654BIB64	LQFP64	plastic low profile quad flat package; 64 leads; body 10 × 10 × 1.4 mm	SOT314-2
SC16C654BIBM	LQFP64	plastic low profile quad flat package; 64 leads; body 7 × 7 × 1.4 mm	SOT414-1
SC16C654BIBS	HVQFN48	plastic thermal enhanced very thin quad flat package; no leads; 48 terminals; body 6 × 6 × 0.85 mm	SOT778-3
SC16C654BIEC	LFBGA64	plastic low profile fine-pitch ball grid array package; 64 balls; body 6 × 6 × 1.05 mm	SOT686-1
SC16C654DBIB64	LQFP64	plastic low profile quad flat package; 64 leads; body 10 × 10 × 1.4 mm	SOT314-2

4. Block diagram



Fig 1. Block diagram of SC16C654B/654DB (16 mode)

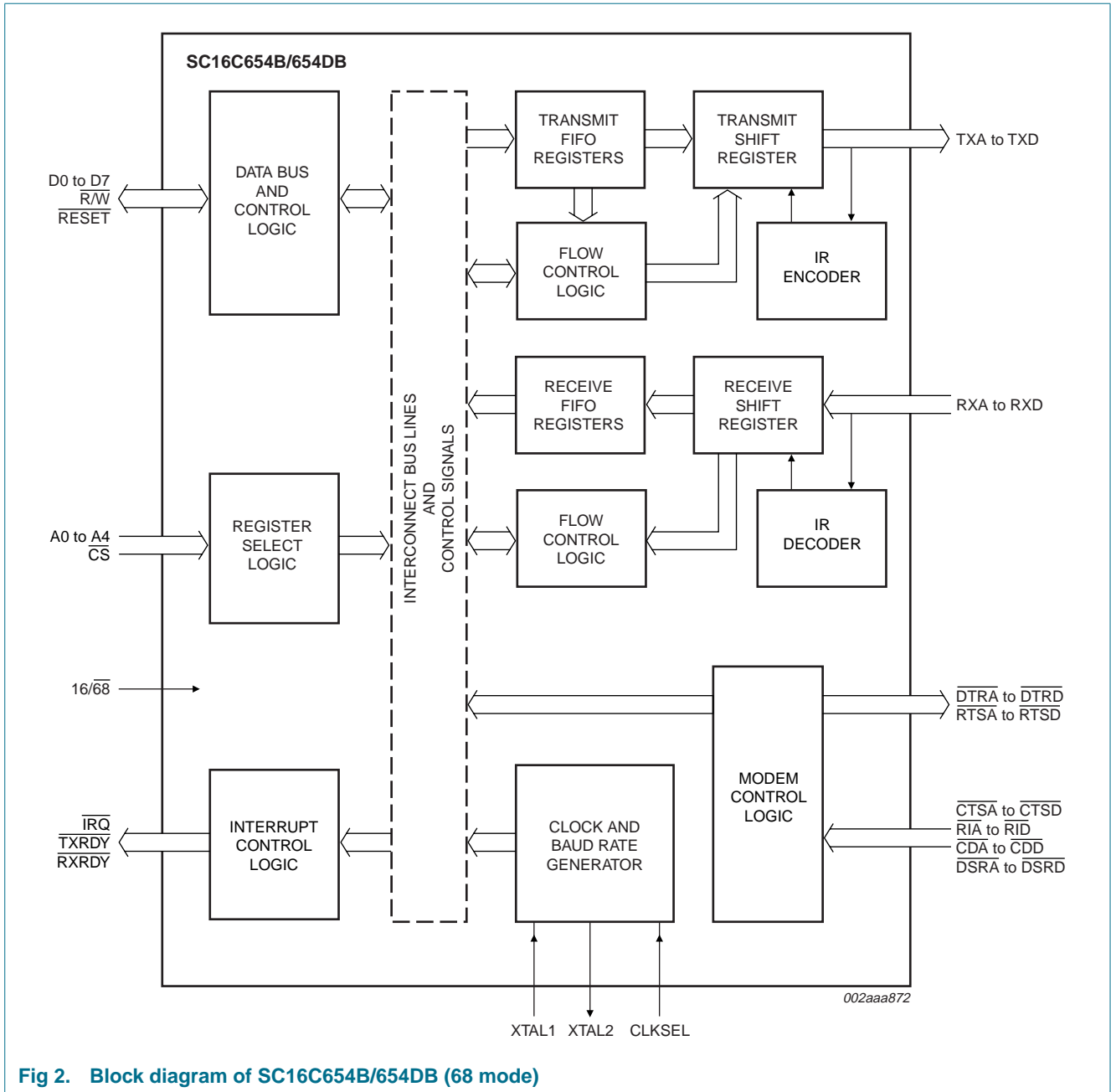

Fig 2. Block diagram of SC16C654B/654DB (68 mode)

5. Pinning information

5.1 Pinning

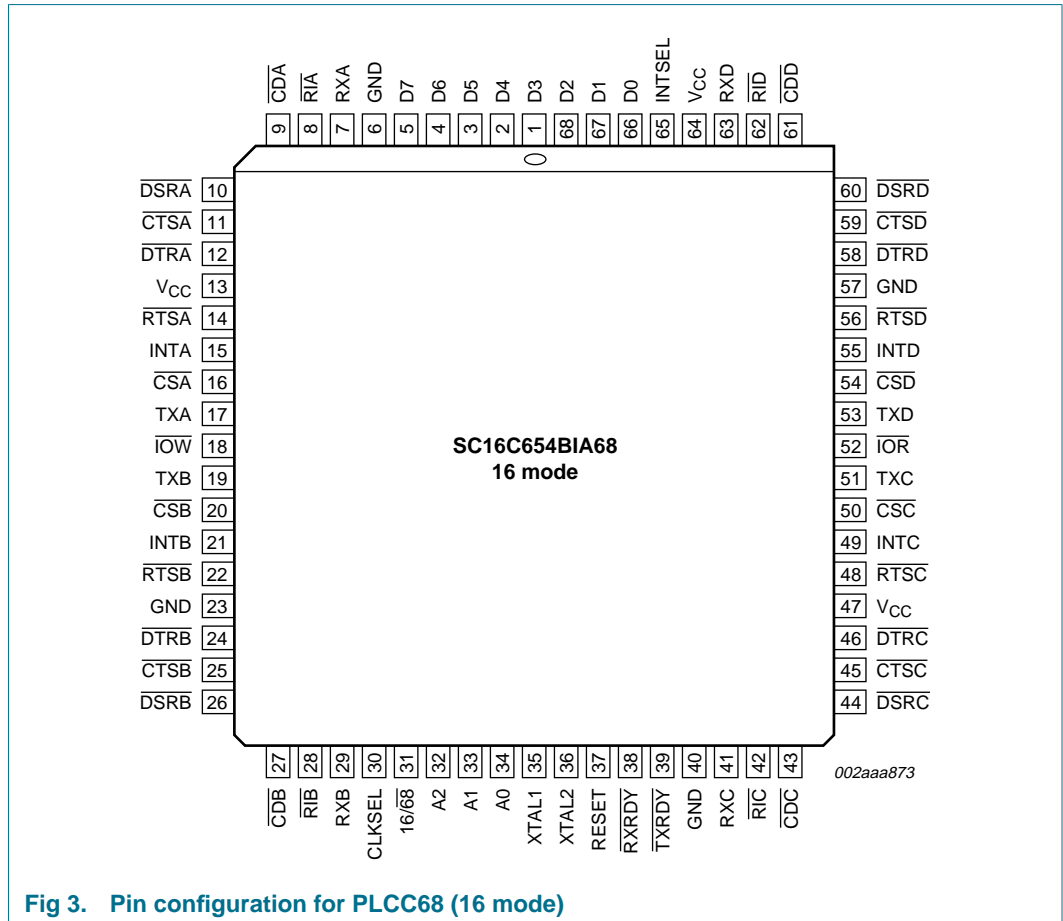

Fig 3. Pin configuration for PLCC68 (16 mode)



Fig 4. Pin configuration for PLCC68 (68 mode)



Fig 5. Pin configuration for LQFP64





Fig 8. Pin configuration for LFBGA64

	1	2	3	4	5	6	7	8	9	10
A	$\overline{\text{CDA}}$	$\overline{\text{RIA}}$	RXA	D7	D5	D3	D1	V _{CC}	$\overline{\text{RID}}$	$\overline{\text{CDD}}$
B	$\overline{\text{DSRA}}$	V _{CC}	GND	D6	D4	D2	D0	RXD	$\overline{\text{DSRD}}$	$\overline{\text{CTSD}}$
C	$\overline{\text{CTSA}}$	$\overline{\text{RTSA}}$							$\overline{\text{DTRD}}$	$\overline{\text{RTSD}}$
D	$\overline{\text{DTRA}}$	INTA							GND	INTD
E	$\overline{\text{CSA}}$	TXA							$\overline{\text{CSD}}$	TXD
F	$\overline{\text{IOW}}$	TXB							$\overline{\text{IOR}}$	TXC
G	$\overline{\text{CSB}}$	INTB							$\overline{\text{CSC}}$	INTC
H	GND	$\overline{\text{RTSB}}$							$\overline{\text{RTSC}}$	V _{CC}
J	$\overline{\text{DTRB}}$	$\overline{\text{CTSB}}$	$\overline{\text{RIB}}$	V _{CC}	A1	XTAL1	RESET	RXC	$\overline{\text{CDC}}$	$\overline{\text{DTRC}}$
K	$\overline{\text{DSRB}}$	$\overline{\text{CDB}}$	RXB	A2	A0	XTAL2	GND	$\overline{\text{RIC}}$	$\overline{\text{DSRC}}$	$\overline{\text{CTSC}}$

002aab567

Fig 9. Ball mapping for LFBGA64

5.2 Pin description

Table 2: Pin description

Symbol	Pin				Type	Description
	PLCC68	LQFP64	HVQFN48	LFPGA64		
$\overline{16/68}$	31	-	14	-	I	16/68 Interface type select (input with internal pull-up). This input provides the 16 (Intel) or 68 (Motorola) bus interface type select. The functions of \overline{IOR} , \overline{IOW} , INTA to INTD, and \overline{CSA} to \overline{CSD} are re-assigned with the logical state of this pin. When this pin is a logic 1, the 16 mode interface (16C654) is selected. When this pin is a logic 0, the 68 mode interface (68C654) is selected. When this pin is a logic 0, \overline{IOW} is re-assigned to R/\overline{W} , RESET is re-assigned to \overline{RESET} , \overline{IOR} is not used, and INTA to INTD are connected in a wire-OR configuration. The wire-OR outputs are connected internally to the open-drain IRQ signal output. This pin is not available on 64-pin packages which operate in the 16 mode only.
A0	34	24	17	K5	I	Address 0 select bit. Internal registers address selection in 16 and 68 modes.
A1	33	23	16	J5	I	Address 1 select bit. Internal registers address selection in 16 and 68 modes.
A2	32	22	15	K4	I	Address 2 select bit. Internal registers address selection in 16 and 68 modes.
A3	20	-	9	-	I	Address 3, Address 4 select bits. When the 68 mode is selected, these pins are used to address or select individual UARTs (providing \overline{CS} is a logic 0). In the 16 mode, these pins are re-assigned as chip selects, see \overline{CSB} and \overline{CSC} . These pins are not available on 64-pin packages which operate in the 16 mode only.
A4	50	-	31	-	I	
\overline{CDA}	9	64	-	A1	I	Carrier Detect (active LOW). These inputs are associated with individual UART channels A through D. A logic 0 on this pin indicates that a carrier has been detected by the modem for that channel.
\overline{CDB}	27	18	-	K2	I	
\overline{CDC}	43	31	24	J9	I	
\overline{CDD}	61	49	-	A10	I	
CLKSEL	30	-	-	-	I	Clock Select. The 1× or 4× pre-scalable clock is selected by this pin. The 1× clock is selected when CLKSEL is a logic 1 (connected to V_{CC}) or the 4× is selected when CLKSEL is a logic 0 (connected to GND). MCR[7] can override the state of this pin following reset or initialization (see MCR[7]). This pin is not available on 64-pin packages which provide MCR[7] selection only.
\overline{CS}	16	-	5	-	I	Chip Select (active LOW). In the 68 mode, this pin functions as a multiple channel chip enable. In this case, all four UARTs (A to D) are enabled when the \overline{CS} pin is a logic 0. An individual UART channel is selected by the data contents of address bits A[3:4]. when the 16 mode is selected (68-pin devices), this pin functions as \overline{CSA} (see definition under \overline{CSA} , \overline{CSB}). This pin is not available on 64-pin packages which operate in the 16 mode only.

Table 2: Pin description ...continued

Symbol	Pin				Type	Description
	PLCC68	LQFP64	HVQFN48	LFBGA64		
$\overline{\text{CSA}}$	16	7	5	E1	I	Chip Select A, B, C, D (active LOW). This function is associated with the 16 mode only, and for individual channels 'A' through 'D'. When in 16 mode, these pins enable data transfers between the user CPU and the SC16C654B/654DB for the channel(s) addressed. Individual UART sections (A, B, C, D) are addressed by providing a logic 0 on the respective CSA to CSD pin. When the 68 mode is selected, the functions of these pins are re-assigned. 68 mode functions are described under their respective name/pin headings.
$\overline{\text{CSB}}$	20	11	9	G1		
$\overline{\text{CSC}}$	50	38	31	G9		
$\overline{\text{CSD}}$	54	42	35	E9		
$\overline{\text{CTSA}}$	11	2	1	C1	I	Clear to Send (active LOW). These inputs are associated with individual UART channels A through D. A logic 0 on the $\overline{\text{CTS}}$ pin indicates the modem or data set is ready to accept transmit data from the SC16C654B/654DB. Status can be tested by reading MSR[4]. This pin only affects the transmit or receive operations when Auto CTS function is enabled via the Enhanced Feature Register EFR[7] for hardware flow control operation.
$\overline{\text{CTSB}}$	25	16	12	J2		
$\overline{\text{CTSC}}$	45	33	26	K10		
$\overline{\text{CTSD}}$	59	47	-	B10		
D0 to D2, D3 to D7	66 to 68 , 1 to 5	53 to 55, 56 to 60	39 to 41, 42 to 46	B7, A7, B6, A6, B5, A5, B4, A4	I/O	Data bus (bi-directional). These pins are the 8-bit, 3-state data bus for transferring information to or from the controlling CPU. D0 is the least significant bit and the first data bit in a transmit or receive serial data stream.
$\overline{\text{DSRA}}$	10	1	-	B1	I	Data Set Ready (active LOW). These inputs are associated with individual UART channels, A through D. A logic 0 on this pin indicates the modem or data set is powered-on and is ready for data exchange with the UART. This pin has no effect on the UART's transmit or receive operation.
$\overline{\text{DSRB}}$	26	17	-	K1		
$\overline{\text{DSRC}}$	44	32	25	K9		
$\overline{\text{DSRD}}$	60	48	-	B9		
$\overline{\text{DTRA}}$	12	3	-	D1	O	Data Terminal Ready (active LOW). These outputs are associated with individual UART channels, A through D. A logic 0 on this pin indicates that the SC16C654B/654DB is powered-on and ready. This pin can be controlled via the modem control register. Writing a logic 1 to MCR[0] will set the $\overline{\text{DTR}}$ output to logic 0, enabling the modem. This pin will be a logic 1 after writing a logic 0 to MCR[0], or after a reset. This pin has no effect on the UART's transmit or receive operation.
$\overline{\text{DTRB}}$	24	15	-	J1		
$\overline{\text{DTRC}}$	46	34	27	J10		
$\overline{\text{DTRD}}$	58	46	-	C9		
GND	6, 23, 40, 57	14, 28, 45, 61	21, 37, 47	B3, K7, H1, D9	I	Signal and power ground.
INTA	15	6	4	D2	O	Interrupt A, B, C, D (active HIGH). This function is associated with the 16 mode only. These pins provide individual channel interrupts INTA to INTD. INTA to INTD are enabled when MCR[3] is set to a logic 1, interrupts are enabled in the interrupt enable register (IER), and when an interrupt condition exists. Interrupt conditions include: receiver errors, available receiver buffer data, transmit buffer empty, or when a modem status flag is detected. When the 68 mode is selected, the functions of these pins are re-assigned. 68 mode functions are described under their respective name/pin headings.
INTB	21	12	10	G2		
INTC	49	37	30	G10		
INTD	55	43	36	D10		

Table 2: Pin description ...continued

Symbol	Pin				Type	Description
	PLCC68	LQFP64	HVQFN48	LFBGA64		
INTSEL	65	-	-	-	I	Interrupt Select (active HIGH, with internal pull-down). This function is associated with the 16 mode only. When the 16 mode is selected, this pin can be used in conjunction with MCR[3] to enable or disable the 3-state interrupts, INTA to INTD, or override MCR[3] and force continuous interrupts. Interrupt outputs are enabled continuously by making this pin a logic 1. Making this pin a logic 0 allows MCR[3] to control the 3-state interrupt output. In this mode, MCR[3] is set to a logic 1 to enable the 3-state outputs. This pin is disabled in the 68 mode. Due to pin limitations on the 64-pin packages, this pin is not available. To cover this limitation, the SC16C654DBIB64 version operates in the continuous interrupt enable mode by bonding this pin to V _{CC} internally. The SC16C654BIB64 operates with MCR[3] control by bonding this pin to GND.
$\overline{\text{IOR}}$	52	40	33	F9	I	Input/Output Read strobe (active LOW). This function is associated with the 16 mode only. A logic 0 transition on this pin will load the contents of an internal register defined by address bits A[0:2] onto the SC16C654B/654DB data bus (D[0:7]) for access by external CPU. This pin is disabled in the 68 mode.
$\overline{\text{IOW}}$	18	9	7	F1	I	Input/Output Write strobe (active LOW). This function is associated with the 16 mode only. A logic 0 transition on this pin will transfer the contents of the data bus (D[0:7]) from the external CPU to an internal register that is defined by address bits A[0:2]. When the 68 mode is selected (PLCC68), this pin functions as R/ $\overline{\text{W}}$ (see definition under R/ $\overline{\text{W}}$).
$\overline{\text{IRQ}}$	15	-	4	-	O	Interrupt Request or Interrupt 'A'. This function is associated with the 68 mode only. In the 68 mode, interrupts from UART channels A-D are wire-ORed internally to function as a single IRQ interrupt. This pin transitions to a logic 0 (if enabled by the interrupt enable register) whenever a UART channel(s) requires service. Individual channel interrupt status can be determined by addressing each channel through its associated internal register, using CS and A[3:4]. In the 68 mode, and external pull-up resistor must be connected between this pin and V _{CC} . The function of this pin changes to INTA when operating in the 16 mode (see definition under INTA).
n.c.	21, 49, 52, 54, 55, 65	-	-	-	-	not connected
$\overline{\text{RESET}}$, RESET	37	27	20	J7	I	Reset. In the 16 mode, a logic 1 on this pin will reset the internal registers and all the outputs. The UART transmitter output and the receiver input will be disabled during reset time. (See Section 7.11 "SC16C654B/654DB external reset conditions" for initialization details.) When 16/68 is a logic 0 (68 mode), this pin functions similarly, but as an inverted reset interface signal, RESET.

Table 2: Pin description ...continued

Symbol	Pin				Type	Description
	PLCC68	LQFP64	HVQFN48	LFBGA64		
$\overline{\text{RIA}}$	8	63	-	A2	I	Ring Indicator (active LOW). These inputs are associated with individual UART channels, A through D. A logic 0 on this pin indicates the modem has received a ringing signal from the telephone line. A logic 1 transition on this input pin will generate an interrupt.
$\overline{\text{RIB}}$	28	19	-	J3		
$\overline{\text{RIC}}$	42	30	23	K8		
$\overline{\text{RID}}$	62	50	-	A9		
$\overline{\text{RTSA}}$	14	5	3	C2	O	Request to Send (active LOW). These outputs are associated with individual UART channels, A through D. A logic 0 on the $\overline{\text{RTS}}$ pin indicates the transmitter has data ready and waiting to send. Writing a logic 1 in the modem control register MCR[1] will set this pin to a logic 0, indicating data is available. After a reset this pin will be set to a logic 1. This pin only affects the transmit and receive operations when Auto RTS function is enabled via the Enhanced Feature Register (EFR[6]) for hardware flow control operation.
$\overline{\text{RTSB}}$	22	13	11	H2		
$\overline{\text{RTSC}}$	48	36	29	H9		
$\overline{\text{RTSD}}$	56	44	-	C10		
$\overline{\text{R/W}}$	18	-	7	-	I	Read/Write strobe. This function is associated with the 68 mode only. This pin provides the combined functions for Read or Write strobes. Logic 1 = Read from UART register selected by $\overline{\text{CS}}$ and A[0:4]. Logic 0 = Write to UART register selected by $\overline{\text{CS}}$ and A[0:4].
RXA	7	62	48	A3	I	Receive data input RXA-RXD. These inputs are associated with individual serial channel data to the SC16C654B/654DB. The RX signal will be a logic 1 during reset, idle (no data), or when the transmitter is disabled. During the local loop-back mode, the RX input pin is disabled and TX data is connected to the UART RX input internally.
RXB	29	20	13	K3		
RXC	41	29	22	J8		
RXD	63	51	38	B8		
$\overline{\text{RXRDY}}$	38	-	-	-	O	Receive Ready (active LOW). This function is associated with 68-pin package only. $\overline{\text{RXRDY}}$ contains the wire-ORed status of all four receive channel FIFOs, RXRDYA-RXRDYD. A logic 0 indicates receive data ready status, that is, the RHR is full, or the FIFO has one or more RX characters available for unloading. This pin goes to a logic 1 when the FIFO/RHR is empty, or when there are no more characters available in either the FIFO or RHR. Individual channel RX status is read by examining individual internal registers via $\overline{\text{CS}}$ and A[0:4] pin functions.
TXA	17	8	6	E2	O	Transmit data A, B, C, D. These outputs are associated with individual serial transmit channel data from the SC16C654B/654DB. The TX signal will be a logic 1 during reset, idle (no data), or when the transmitter is disabled. During the local loop-back mode, the TX output pin is disabled and TX data is internally connected to the UART RX input.
TXB	19	10	8	F2		
TXC	51	39	32	F10		
TXD	53	41	34	E10		

Table 2: Pin description ...continued

Symbol	Pin				Type	Description
	PLCC68	LQFP64	HVQFN48	LFPGA64		
TXRDY	39	-	-	-	O	Transmit Ready (active LOW). This function is associated with the 68-pin package only. TXRDY contains the wire-ORed status of all four transmit channel FIFOs, TXRDYA-TXRDYD. A logic 0 indicates a buffer ready status, that is, at least one location is empty and available in one of the TX channels (A to D). This pin goes to a logic 1 when all four channels have no more empty locations in the TX FIFO or THR. Individual channel TX status can be read by examining individual internal registers via CS and A[0:4] pin functions.
V _{CC}	13, 47, 64	4, 21, 35, 52	2, 28	A8, B2, J4, H10	I	Power supply inputs.
XTAL1	35	25	18	J6	I	Crystal or external clock input. Functions as a crystal input or as an external clock input. A crystal can be connected between this pin and XTAL2 to form an internal oscillator circuit; see Figure 10 . Alternatively, an external clock can be connected to this pin to provide custom data rates; see Section 6.9 "Programmable baud rate generator" .
XTAL2	36	26	19	K6	O	Output of the crystal oscillator or buffered clock. (See also XTAL1.) Crystal oscillator output or buffered clock output.

6. Functional description

The SC16C654B/654DB provides serial asynchronous receive data synchronization, parallel-to-serial and serial-to-parallel data conversions for both the transmitter and receiver sections. These functions are necessary for converting the serial data stream into parallel data that is required with digital data systems. Synchronization for the serial data stream is accomplished by adding start and stop bits to the transmit data to form a data character. Data integrity is insured by attaching a parity bit to the data character. The parity bit is checked by the receiver for any transmission bit errors. The electronic circuitry to provide all these functions is fairly complex, especially when manufactured on a single integrated silicon chip. The SC16C654B/654DB represents such an integration with greatly enhanced features. The SC16C654B/654DB is fabricated with an advanced CMOS process to achieve low drain power and high speed requirements.

The SC16C654B/654DB is an upward solution that provides 64 bytes of transmit and receive FIFO memory, instead of 16 bytes provided in the 16C554, or none in the 16C454. The SC16C654B/654DB is designed to work with high speed modems and shared network environments that require fast data processing time. Increased performance is realized in the SC16C654B/654DB by the larger transmit and receive FIFOs. This allows the external processor to handle more networking tasks within a given time. For example, the SC16C554 with a 16-byte FIFO unloads 16 bytes of receive data in 1.53 ms. (This example uses a character length of 11 bits, including start/stop bits at 115.2 kbit/s.) This means the external CPU will have to service the receive FIFO at 1.53 ms intervals. However, with the 64-byte FIFO in the SC16C654B/654DB, the data buffer will not require unloading/loading for 6.1 ms. This increases the service interval, giving the external CPU additional time for other applications and reducing the overall UART interrupt servicing

time. In addition, the four selectable levels of FIFO trigger interrupt and automatic hardware/software flow control is uniquely provided for maximum data throughput performance, especially when operating in a multi-channel environment. The combination of the above greatly reduces the bandwidth requirement of the external controlling CPU, increases performance, and reduces power consumption.

The SC16C654B/654DB combines the package interface modes of the 16C454/554 and 68C454/554 series on a single integrated chip. The 16 mode interface is designed to operate with the Intel-type of microprocessor bus, while the 68 mode is intended to operate with Motorola and other popular microprocessors. Following a reset, the SC16C654B/654DB is downward compatible with the 16C454/554 or the 68C454/554, dependent on the state of the interface mode selection pin, 16/68.

The SC16C654B/654DB is capable of operation to 1.5 Mbit/s with a 24 MHz crystal and up to 5 Mbit/s with an external clock input (at 3.3 V and 5 V; at 2.5 V the max speed is 3 Mbit/s). With a crystal of 14.7464 MHz, and through a software option, the user can select data rates up to 460.8 kbit/s or 921.6 kbit/s, 8 times faster than the 16C554.

The rich feature set of the SC16C654B/654DB is available through internal registers. Automatic hardware/software flow control, selectable transmit and receive FIFO trigger levels, selectable TX and RX baud rates, infrared encoder/decoder interface, modem interface controls, and a sleep mode are all standard features. MCR[5] provides a facility for turning off (Xon) software flow control with any incoming (RX) character. In the 16 mode, INTSEL and MCR[3] can be configured to provide a software controlled or continuous interrupt capability. Due to pin limitations of the 64-pin package, this feature is offered by two different LQFP64 packages. The SC16C654DB operates in the continuous interrupt enable mode by bonding INTSEL to V_{CC} internally. The SC16C654B operates in conjunction with MCR[3] by bonding INTSEL to GND internally.

The PLCC68 SC16C654B package offers a clock select pin to allow system/board designers to preset the default baud rate table. The CLKSEL pin selects the 1× or 4× pre-scalable baud rate generator table during initialization, but can be overridden following initialization by MCR[7].

6.1 Interface options

Two user interface modes are selectable for the PLCC68 package. These interface modes are designated as the '16 mode' and the '68 mode'. This nomenclature corresponds to the early 16C454/554 and 68C454/554 package interfaces respectively.

6.1.1 The 16 mode interface

The 16 mode configures the package interface pins for connection as a standard 16 series (Intel) device and operates similar to the standard CPU interface available on the 16C454/554. In the 16 mode (pin 16/68 = logic 1), each UART is selected with individual chip select (\overline{CSx}) pins, as shown in [Table 3](#).

Table 3: Serial port channel selection, 16 mode interface

CSA	CSB	CSC	CSD	UART channel
1	1	1	1	none
0	1	1	1	A
1	0	1	1	B
1	1	0	1	C
1	1	1	0	D

6.1.2 The 68 mode interface

The 68 mode configures the package interface pins for connection with Motorola, and other popular microprocessor bus types. The interface operates similar to the 68C454/554. In this mode, the SC16C654B/654DB decodes two additional addresses, A3-A4, to select one of the four UART ports. The A[3:4] address decode function is used only when in the 68 mode (16/68 = logic 0), and is shown in [Table 4](#).

Table 4: Serial port channel selection, 68 mode interface

\overline{CS}	A4	A3	UART channel
1	n/a	n/a	none
0	0	0	A
0	0	1	B
0	1	0	C
0	1	1	D

6.2 Internal registers

The SC16C654B/654DB provides 17 internal registers for monitoring and control. These registers are shown in [Table 5](#). Twelve registers are similar to those already available in the standard 16C554. These registers function as data holding registers (THR/RHR), interrupt status and control registers (IER/ISR), a FIFO control register (FCR), line status and control registers (LCR/LSR), modem status and control registers (MCR/MSR), programmable data rate (clock) control registers (DLL/DLM), and a user accessible scratchpad register (SPR). Beyond the general 16C554 features and capabilities, the SC16C654B/654DB offers an enhanced feature register set (EFR, Xon/Xoff1-2) that provides on-board hardware/software flow control. Register functions are more fully described in the following paragraphs.

Table 5: Internal registers decoding

A2	A1	A0	Read mode	Write mode
General register set (THR/RHR, IER/ISR, MCR/MSR, FCR, LSR, SPR) [1]				
0	0	0	Receive Holding Register	Transmit Holding Register
0	0	1	Interrupt Enable Register	Interrupt Enable Register
0	1	0	Interrupt Status Register	FIFO Control Register
0	1	1	Line Control Register	Line Control Register
1	0	0	Modem Control Register	Modem Control Register
1	0	1	Line Status Register	n/a
1	1	0	Modem Status Register	n/a
1	1	1	Scratchpad Register	Scratchpad Register
Baud rate register set (DLL/DLM) [2]				
0	0	0	LSB of Divisor Latch	LSB of Divisor Latch
0	0	1	MSB of Divisor Latch	MSB of Divisor Latch
Enhanced register set (EFR, Xon/off 1-2) [3]				
0	1	0	Enhanced Feature Register	Enhanced Feature Register
1	0	0	Xon1 word	Xon1 word
1	0	1	Xon2 word	Xon2 word
1	1	0	Xoff1 word	Xoff1 word
1	1	1	Xoff2 word	Xoff2 word

[1] These registers are accessible only when LCR[7] is a logic 0.

[2] These registers are accessible only when LCR[7] is a logic 1.

[3] Enhanced Feature Register, Xon1, 2 and Xoff1, 2 are accessible only when the LCR is set to 'BFh'.

6.3 FIFO operation

The 64-byte transmit and receive data FIFOs are enabled by the FIFO Control Register (FCR) bit 0. With SC16C554 devices, the user can set the receive trigger level, but not the transmit trigger level. The SC16C654B/654DB provides independent trigger levels for both receiver and transmitter. To remain compatible with SC16C554, the transmit interrupt trigger level is set to 8 following a reset. It should be noted that the user can set the transmit trigger levels by writing to the FCR register, but activation will not take place until EFR[4] is set to a logic 1. The receiver FIFO section includes a time-out function to ensure data is delivered to the external CPU. An interrupt is generated whenever the Receive

Holding Register (RHR) has not been read following the loading of a character or the receive trigger level has not been reached. (For a description of this timing, see [Section 6.4 "Hardware flow control"](#).)

Table 6: RX trigger levels

Selected trigger level (characters)	INT pin activation	Negate $\overline{\text{RTS}}$ or send Xoff (characters)	Assert $\overline{\text{RTS}}$ or send Xon (characters)
8	8	16	0
16	16	56	8
56	56	60	16
60	60	60	56

6.4 Hardware flow control

When automatic hardware flow control is enabled, the SC16C654B/654DB monitors the $\overline{\text{CTS}}$ pin for a remote buffer overflow indication and controls the $\overline{\text{RTS}}$ pin for local buffer overflows. Automatic hardware flow control is selected by setting EFR[6] (RTS) and EFR[7] (CTS) to a logic 1. If $\overline{\text{CTS}}$ transitions from a logic 0 to a logic 1 indicating a flow control request, ISR[5] will be set to a logic 1 (if enabled via IER[6,7]), and the SC16C654B/654DB will suspend TX transmissions as soon as the stop bit of the character in process is shifted out. Transmission is resumed after the $\overline{\text{CTS}}$ input returns to a logic 0, indicating more data may be sent.

With the Auto $\overline{\text{RTS}}$ function enabled, an interrupt is generated when the receive FIFO reaches the programmed trigger level. The $\overline{\text{RTS}}$ pin will not be forced to a logic 1 (RTS off), until the receive FIFO reaches the next trigger level. However, the $\overline{\text{RTS}}$ pin will return to a logic 0 after the data buffer (FIFO) is unloaded to the next trigger level below the programmed trigger. However, under the above described conditions, the SC16C654B/654DB will continue to accept data until the receive FIFO is full.

Remark: Hardware flow control is not supported on channel D in the HVQFN48 package.

6.5 Software flow control

When software flow control is enabled, the SC16C654B/654DB compares one or two sequential receive data characters with the programmed Xon/Xoff or Xoff1,2 character value(s). If received character(s) match the programmed values, the SC16C654B/654DB will halt transmission (TX) as soon as the current character(s) has completed transmission. When a match occurs, the receive ready (if enabled via Xoff IER[5]) flags will be set and the interrupt output pin (if receive interrupt is enabled) will be activated. Following a suspension due to a match of the Xoff characters' values, the SC16C654B/654DB will monitor the receive data stream for a match to the Xon1,2 character value(s). If a match is found, the SC16C654B/654DB will resume operation and clear the flags (ISR[4]). The SC16C654B/654DB offers a special Xon mode via MCR[5]. The initialized default setting of MCR[5] is a logic 0. In this state, Xoff and Xon will operate as defined above. Setting MCR[5] to a logic 1 sets a special operational mode for the Xon function. In this case, Xoff operates normally, however, transmission (Xon) will resume with the next character received, that is, a match is declared simply by the receipt of an incoming (RX) character.

Reset initially sets the contents of the Xon/Xoff 8-bit flow control registers to a logic 0. Following reset, the user can write any Xon/Xoff value desired for software flow control. Different conditions can be set to detect Xon/Xoff characters and suspend/resume transmissions. When double 8-bit Xon/Xoff characters are selected, the SC16C654B/654DB compares two consecutive receive characters with two software flow control 8-bit values (Xon1, Xon2, Xoff1, Xoff2) and controls TX transmissions accordingly. Under the above described flow control mechanisms, flow control characters are not placed (stacked) in the user accessible RX data buffer or FIFO.

In the event that the receive buffer is overflowing and flow control needs to be executed, the SC16C654B/654DB automatically sends an Xoff message (when enabled) via the serial TX output to the remote modem. The SC16C654B/654DB sends the Xoff1,2 characters as soon as received data passes the programmed trigger level. To clear this condition, the SC16C654B/654DB will transmit the programmed Xon1,2 characters as soon as receive data drops below the programmed trigger level.

6.6 Special feature software flow control

A special feature is provided to detect an 8-bit character when EFR[5] is set. When 8-bit character is detected, it will be placed on the user-accessible data stack along with normal incoming RX data. This condition is selected in conjunction with EFR[0:3]. Note that software flow control should be turned off when using this special mode by setting EFR[0:3] to a logic 0.

The SC16C654B/654DB compares each incoming receive character with Xoff2 data. If a match exists, the received data will be transferred to the FIFO, and ISR[4] will be set to indicate detection of a special character. Although the Internal Register Table ([Table 8](#)) shows each X-Register with eight bits of character information, the actual number of bits is dependent on the programmed word length. Line Control Register bits LCR[0:1] define the number of character bits, that is, either 5 bits, 6 bits, 7 bits or 8 bits. The word length selected by LCR[0:1] also determine the number of bits that will be used for the special character comparison. Bit 0 in the X-registers corresponds with the LSB bit for the receive character.

6.7 Xon any feature

A special feature is provided to return the Xoff flow control to the inactive state following its activation. In this mode, any RX character received will return the Xoff flow control to the inactive state so that transmissions may be resumed with a remote buffer. This feature is more fully defined in [Section 6.5 “Software flow control”](#).

6.8 Hardware/software and time-out interrupts

Three special interrupts have been added to monitor the hardware and software flow control. The interrupts are enabled by IER[5:7]. Care must be taken when handling these interrupts. Following a reset, the transmitter interrupt is enabled, the SC16C654B/654DB will issue an interrupt to indicate that the Transmit Holding Register is empty. This interrupt must be serviced prior to continuing operations. The LSR register provides the current singular highest priority interrupt only. It could be noted that CTS and RTS interrupts have lowest interrupt priority. A condition can exist where a higher priority interrupt may mask the lower priority CTS/RTS interrupt(s). Only after servicing the higher pending interrupt will the lower priority CTS/TRS interrupt(s) be reflected in the status register. Servicing the interrupt without investigating further interrupt conditions can result in data errors.

When two interrupt conditions have the same priority, it is important to service these interrupts correctly. Receive Data Ready and Receive Time Out have the same interrupt priority (when enabled by IER[0]). The receiver issues an interrupt after the number of characters have reached the programmed trigger level. In this case, the SC16C654B/654DB FIFO may hold more characters than the programmed trigger level. Following the removal of a data byte, the user should re-check LSR[0] for additional characters. A Receive Time Out will not occur if the receive FIFO is empty. The time-out counter is reset at the center of each stop bit received or each time the receive holding register (RHR) is read. The actual time-out value is 4 character time.

In the 16 mode for the PLCC68 package, the system/board designer can optionally provide software controlled 3-state interrupt operation. This is accomplished by INTSEL and MCR[3]. When INTSEL interface pin is left open or made a logic 0, MCR[3] controls the 3-state interrupt outputs, INTA to INTD. When INTSEL is a logic 1, MCR[3] has no effect on the INTA to INTD outputs, and the package operates with interrupt outputs enabled continuously.

6.9 Programmable baud rate generator

The SC16C654B/654DB supports high speed modem technologies that have increased input data rates by employing data compression schemes. For example, a 33.6 kbit/s modem that employs data compression may require a 115.2 kbit/s input data rate. A 128.0 kbit/s ISDN modem that supports data compression may need an input data rate of 460.8 kbit/s.

A single baud rate generator is provided for the transmitter and receiver, allowing independent TX/RX channel control. The programmable Baud Rate Generator is capable of accepting an input clock up to 80 MHz (for 3.3 V and 5 V operation), as required for supporting a 5 Mbit/s data rate. The SC16C654B/654DB can be configured for internal or external clock operation. For internal clock oscillator operation, an industry standard microprocessor crystal (parallel resonant/22 pF to 33 pF load) is connected externally between the XTAL1 and XTAL2 pins; see [Figure 10](#). Alternatively, an external clock can be connected to the XTAL1 pin to clock the internal baud rate generator for standard or custom rates; see [Table 7](#).

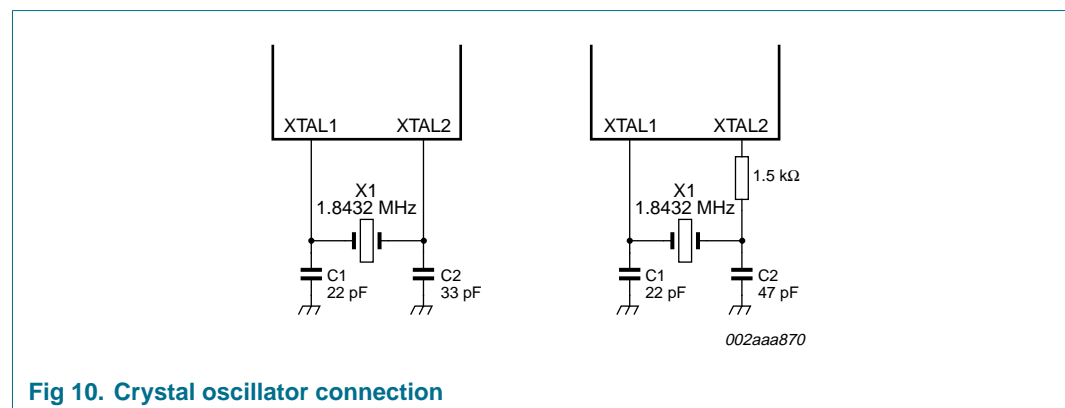

Fig 10. Crystal oscillator connection

The generator divides the input $16\times$ clock by any divisor from 1 to $(2^{16} - 1)$. The SC16C654B/654DB divides the basic external clock by 16. Further division of this $16\times$ clock provides two table rates to support low and high data rate applications using the same system design. After a hardware reset and during initialization, the

SC16C654B/654DB sets the default baud rate table according to the state of the CLKSEL pin. A logic 1 on CLKSEL will set the 1× clock default, whereas logic 0 will set the 4× clock default table. Following the default clock rate selection during initialization, the rate tables can be changed by the internal register MCR[7]. Setting MCR[7] to a logic 1 when CLKSEL is a logic 1 provides an additional divide-by-4, whereas setting MCR[7] to a logic 0 only divides by 1; see [Table 7](#) and [Figure 11](#). Customized baud rates can be achieved by selecting the proper divisor values for the MSB and LSB sections of baud rate generator.

Programming the Baud Rate Generator Registers DLM (MSB) and DLL (LSB) provides a user capability for selecting the desired final baud rate. The example in [Table 7](#) shows the two selectable baud rate tables available when using a 7.3728 MHz crystal.

Table 7: Baud rate generator programming table using a 7.3728 MHz clock

Output baud rate		User 16× clock divisor		DLM program value (HEX)	DLL program value (HEX)
MCR[7] = 1	MCR[7] = 0	Decimal	HEX		
50	200	2304	900	09	00
300	1200	384	180	01	80
600	2400	192	C0	00	C0
1200	4800	96	60	00	60
2400	9600	48	30	00	30
4800	19.2 k	24	18	00	18
9600	38.4 k	12	0C	00	0C
19.2 k	76.8 k	6	06	00	06
38.4 k	153.6 k	3	03	00	03
57.6 k	230.4 k	2	02	00	02
115.2 k	460.8 k	1	01	00	01



Fig 11. Baud rate generator circuitry

6.10 DMA operation

The SC16C654B/654DB FIFO trigger level provides additional flexibility to the user for block mode operation. LSR[5:6] provide an indication when the transmitter is empty or has an empty location(s). The user can optionally operate the transmit and receive FIFOs in the DMA mode (FCR[3]). When the transmit and receive FIFOs are enabled and the DMA mode is de-activated (DMA Mode 0), the SC16C654B/654DB activates the interrupt output pin for each data transmit or receive operation. When DMA mode is activated (DMA Mode 1), the user takes the advantage of block mode operation by loading or unloading the FIFO in a block sequence determined by the preset trigger level. In this mode, the SC16C654B/654DB sets the interrupt output pin when characters in the transmit FIFOs are below the transmit trigger level, or the characters in the receive FIFOs are above the receive trigger level.

Remark: DMA operation is not supported in the HVQFN48 package option.

6.11 Sleep mode

The SC16C654B/654DB is designed to operate with low power consumption. A special sleep mode is included to further reduce power consumption when the chip is not being used. With EFR[4] and IER[4] enabled (set to a logic 1), the SC16C654B/654DB enters the sleep mode, but resumes normal operation when a start bit is detected, a change of state on any of the modem input pins \overline{RX} , \overline{RI} , \overline{CTS} , \overline{DSR} , \overline{CD} , or a transmit data is provided by the user. If the sleep mode is enabled and the SC16C654B/654DB is awakened by one of the conditions described above, it will return to the sleep mode automatically after the last character is transmitted or read by the user. In any case, the sleep mode will not be entered while an interrupt(s) is pending. The SC16C654B/654DB will stay in the sleep mode of operation until it is disabled by setting IER[4] to a logic 0.

6.12 Loop-back mode

The internal loop-back capability allows on-board diagnostics. In the loop-back mode, the normal modem interface pins are disconnected and reconfigured for loop-back internally. MCR[0:3] register bits are used for controlling loop-back diagnostic testing. In the loop-back mode, OP1 and OP2 in the MCR register (bits 2:3) control the modem \overline{RI} and \overline{CD} inputs, respectively. MCR signals \overline{DTR} and \overline{RTS} (bits 0:1) are used to control the modem \overline{DSR} and \overline{CTS} inputs, respectively. The transmitter output (TX) and the receiver input (RX) are disconnected from their associated interface pins, and instead are connected together internally; see [Figure 12](#). The \overline{CTS} , \overline{DSR} , \overline{CD} , and \overline{RI} are disconnected from their normal modem control input pins, and instead are connected internally to \overline{RTS} , \overline{DTR} , OP2 and OP1. Loop-back test data is entered into the transmit holding register via the user data bus interface, D[0:7]. The transmit UART serializes the data and passes the serial data to the receive UART via the internal loop-back connection. The receive UART converts the serial data back into parallel data that is then made available at the user data interface D[0:7]. The user optionally compares the received data to the initial transmitted data for verifying error-free operation of the UART TX/RX circuits.

In this mode, the receiver and transmitter interrupts are fully operational. The Modem Control Interrupts are also operational. However, the interrupts can only be read using lower four bits of the Modem Status Register (MSR[0:3]) instead of the four Modem Status Register bits 4:7. The interrupts are still controlled by the IER.



Fig 12. Internal loop-back mode diagram

7. Register descriptions

[Table 8](#) details the assigned bit functions for the SC16C654B/654DB internal registers. The assigned bit functions are more fully defined in [Section 7.1](#) through [Section 7.11](#).

Table 8: SC16C654B/654DB internal registers

A2	A1	A0	Register	Default [1]	Bit 7	Bit 6	Bit 5	Bit 4	Bit 3	Bit 2	Bit 1	Bit 0
General Register Set [2]												
0	0	0	RHR	XX	bit 7	bit 6	bit 5	bit 4	bit 3	bit 2	bit 1	bit 0
0	0	0	THR	XX	bit 7	bit 6	bit 5	bit 4	bit 3	bit 2	bit 1	bit 0
0	0	1	IER	00	CTS interrupt [3]	RTS interrupt [3]	Xoff interrupt [3]	Sleep mode [3]	modem status interrupt	receive line status interrupt	transmit holding register	receive holding register
0	1	0	FCR	00	RCVR trigger (MSB)	RCVR trigger (LSB)	TX trigger (MSB) [3]	TX trigger (LSB) [3]	DMA mode select [4]	XMIT FIFO reset	RCVR FIFO reset	FIFO enable
0	1	0	ISR	01	FIFOs enabled	FIFOs enabled	INT priority bit 4	INT priority bit 3	INT priority bit 2	INT priority bit 1	INT priority bit 0	INT status
0	1	1	LCR	00	divisor latch enable	set break	set parity	even parity	parity enable	stop bits	word length bit 1	word length bit 0
1	0	0	MCR	00	Clock select [3]	IR enable [3]	Xon Any [3]	loop back	$\overline{OP2}$, INTx enable	$\overline{OP1}$	\overline{RTS}	\overline{DTR}
1	0	1	LSR	60	FIFO data error	trans. empty	trans. holding empty	break interrupt	framing error	parity error	overrun error	receive data ready
1	1	0	MSR	X0	CD	RI	DSR	CTS	$\Delta\overline{CD}$	$\Delta\overline{RI}$	$\Delta\overline{DSR}$	$\Delta\overline{CTS}$
1	1	1	SPR	FF	bit 7	bit 6	bit 5	bit 4	bit 3	bit 2	bit 1	bit 0
Special Register Set [5]												
0	0	0	DLL	XX	bit 7	bit 6	bit 5	bit 4	bit 3	bit 2	bit 1	bit 0
0	0	1	DLM	XX	bit 15	bit 14	bit 13	bit 12	bit 11	bit 10	bit 9	bit 8
Enhanced Register Set [6]												
0	1	0	EFR	00	Auto CTS	Auto RTS	Special char. select	Enable IER[4:7], ISR[4:5], FCR[4:5], MCR[5:7]	Cont-3 Tx, Rx Control	Cont-2 Tx, Rx Control	Cont-1 Tx, Rx Control	Cont-0 Tx, Rx Control
1	0	0	Xon-1	00	bit 7	bit 6	bit 5	bit 4	bit 3	bit 2	bit 1	bit 0
1	0	1	Xon-2	00	bit 15	bit 14	bit 13	bit 12	bit 11	bit 10	bit 9	bit 8
1	1	0	Xoff-1	00	bit 7	bit 6	bit 5	bit 4	bit 3	bit 2	bit 1	bit 0
1	1	1	Xoff-2	00	bit 15	bit 14	bit 13	bit 12	bit 11	bit 10	bit 9	bit 8

[1] The value shown represents the register's initialized HEX value; X = not applicable.

[2] These registers are accessible only when LCR[7] = 0.

[3] These bits are only accessible when EFR[4] is set.

[4] This function is not supported in the HVQFN48 package; \overline{TXRDY} and \overline{RXRDY} are removed.

[5] The Special Register set is accessible only when LCR[7] is set to a logic 1.

[6] Enhanced Feature Register, Xon1/Xon2 and Xoff1/Xoff2 are accessible only when LCR is set to 'BFh'.

7.1 Transmit (THR) and Receive (RHR) Holding Registers

The serial transmitter section consists of an 8-bit Transmit Hold Register (THR) and Transmit Shift Register (TSR). The status of the THR is provided in the Line Status Register (LSR). Writing to the THR transfers the contents of the data bus (D7 to D0) to the THR, providing that the THR or TSR is empty. The THR empty flag in the LSR register will be set to a logic 1 when the transmitter is empty or when data is transferred to the TSR. Note that a write operation can be performed when the THR empty flag is set (logic 0 = FIFO full; logic 1 = at least one FIFO location available).

The serial receive section also contains an 8-bit Receive Holding Register (RHR). Receive data is removed from the SC16C654B/654DB and receive FIFO by reading the RHR register. The receive section provides a mechanism to prevent false starts. On the falling edge of a start or false start bit, an internal receiver counter starts counting clocks at the 16× clock rate. After 7½ clocks, the start bit time should be shifted to the center of the start bit. At this time the start bit is sampled, and if it is still a logic 0 it is validated. Evaluating the start bit in this manner prevents the receiver from assembling a false character. Receiver status codes will be posted in the LSR.

7.2 Interrupt Enable Register (IER)

The Interrupt Enable Register (IER) masks the interrupts from receiver ready, transmitter empty, line status and modem status registers. These interrupts would normally be seen on the INTA to INTD output pins in the 16 mode, or on wire-OR IRQ output pin in the 68 mode.

Table 9: Interrupt Enable Register bits description

Bit	Symbol	Description
7	IER[7]	CTS interrupt. logic 0 = disable the CTS interrupt (normal default condition) logic 1 = enable the CTS interrupt. The SC16C654B/654DB issues an interrupt when the CTS pin transitions from a logic 0 to a logic 1.
6	IER[6]	RTS interrupt. logic 0 = disable the RTS interrupt (normal default condition) logic 1 = enable the RTS interrupt. The SC16C654B/654DB issues an interrupt when the RTS pin transitions from a logic 0 to a logic 1.
5	IER[5]	Xoff interrupt. logic 0 = disable the software flow control, receive Xoff interrupt (normal default condition) logic 1 = enable the software flow control, receive Xoff interrupt. See Section 6.5 “Software flow control” for details.
4	IER[4]	Sleep mode. logic 0 = disable Sleep mode (normal default condition) logic 1 = enable Sleep mode. See Section 6.11 “Sleep mode” for details.
3	IER[3]	Modem Status Interrupt. logic 0 = disable the modem status register interrupt (normal default condition) logic 1 = enable the modem status register interrupt

Table 9: Interrupt Enable Register bits description ...continued

Bit	Symbol	Description
2	IER[2]	Receive Line Status interrupt. logic 0 = disable the receiver line status interrupt (normal default condition) logic 1 = enable the receiver line status interrupt
1	IER[1]	Transmit Holding Register interrupt. This interrupt will be issued whenever the THR is empty, and is associated with LSR[1]. logic 0 = disable the transmitter empty interrupt (normal default condition) logic 1 = enable the transmitter empty interrupt
0	IER[0]	Receive Holding Register interrupt. This interrupt will be issued when the FIFO has reached the programmed trigger level, or is cleared when the FIFO drops below the trigger level in the FIFO mode of operation. logic 0 = disable the receiver ready interrupt (normal default condition) logic 1 = enable the receiver ready interrupt

7.2.1 IER versus Receive FIFO interrupt mode operation

When the receive FIFO (FCR[0] = logic 1), and receive interrupts (IER[0] = logic 1) are enabled, the receive interrupts and register status will reflect the following:

- The receive data available interrupts are issued to the external CPU when the FIFO has reached the programmed trigger level. It will be cleared when the FIFO drops below the programmed trigger level.
- FIFO status will also be reflected in the user accessible ISR register when the FIFO trigger level is reached. Both the ISR register status bit and the interrupt will be cleared when the FIFO drops below the trigger level.
- The data ready bit (LSR[0]) is set as soon as a character is transferred from the shift register to the receive FIFO. It is reset when the FIFO is empty.

7.2.2 IER versus Receive/Transmit FIFO polled mode operation

When FCR[0] = logic 1, resetting IER[0:3] enables the SC16C654B/654DB in the FIFO polled mode of operation. Since the receiver and transmitter have separate bits in the LSR, either or both can be used in the polled mode by selecting respective transmit or receive control bit(s).

- LSR[0] will be a logic 1 as long as there is one byte in the receive FIFO.
- LSR[1:4] will provide the type of errors encountered, if any.
- LSR[5] will indicate when the transmit FIFO is empty.
- LSR[6] will indicate when both the transmit FIFO and transmit shift register are empty.
- LSR[7] will indicate any FIFO data errors.

7.3 FIFO Control Register (FCR)

This register is used to enable the FIFOs, clear the FIFOs, set the transmit/receive FIFO trigger levels, and select the DMA mode.

7.3.1 DMA mode

7.3.1.1 Mode 0 (FCR bit 3 = 0)

Set and enable the interrupt for each single transmit or receive operation, and is similar to the 16C454 mode. Transmit Ready ($\overline{\text{TXRDY}}$) will go to a logic 0 whenever an empty transmit space is available in the Transmit Holding Register (THR). Receive Ready ($\overline{\text{RXRDY}}$) will go to a logic 0 whenever the Receive Holding Register (RHR) is loaded with a character.

7.3.1.2 Mode 1 (FCR bit 3 = 1)

Set and enable the interrupt in a block mode operation. The transmit interrupt is set when the transmit FIFO is below the programmed trigger level. $\overline{\text{TXRDY}}$ remains a logic 0 as long as one empty FIFO location is available. The receive interrupt is set when the receive FIFO fills to the programmed trigger level. However, the FIFO continues to fill regardless of the programmed level until the FIFO is full. $\overline{\text{RXRDY}}$ remains a logic 0 as long as the FIFO fill level is above the programmed trigger level.

7.3.2 FIFO mode

Table 10: FIFO Control Register bits description

Bit	Symbol	Description
7:6	FCR[7] (MSB), FCR[6] (LSB)	RCVR trigger. These bits are used to set the trigger level for the receive FIFO interrupt. An interrupt is generated when the number of characters in the FIFO equals the programmed trigger level. However, the FIFO will continue to be loaded until it is full. Refer to Table 11 .
5:4	FCR[5] (MSB), FCR[4] (LSB)	TX trigger. These bits are used to set the trigger level for the transmit FIFO interrupt. The SC16C654B/654DB will issue a transmit empty interrupt when the number of characters in FIFO drops below the selected trigger level. Refer to Table 12 .
3	FCR[3]	DMA mode select. logic 0 = set DMA mode '0' (normal default condition) logic 1 = set DMA mode '1' Transmit operation in mode '0': When the SC16C654B/654DB is in the 16C454 mode (FIFOs disabled; FCR[0] = logic 0) or in the FIFO mode (FIFOs enabled; FCR[0] = logic 1; FCR[3] = logic 0), and when there are no characters in the transmit FIFO or transmit holding register, the $\overline{\text{TXRDY}}$ pin will be a logic 0. Once active, the $\overline{\text{TXRDY}}$ pin will go to a logic 1 after the first character is loaded into the transmit holding register. Receive operation in mode '0': When the SC16C654B/654DB is in mode '0' (FCR[0] = logic 0), or in the FIFO mode (FCR[0] = logic 1; FCR[3] = logic 0) and there is at least one character in the receive FIFO, the $\overline{\text{RXRDY}}$ pin will be a logic 0. Once active, the $\overline{\text{RXRDY}}$ pin will go to a logic 1 when there are no more characters in the receiver.

Table 10: FIFO Control Register bits description ...continued

Bit	Symbol	Description
3 (cont.)	FCR[3] (continued)	<p>Transmit operation in mode '1': When the SC16C654B/654DB is in FIFO mode (FCR[0] = logic 1; FCR[3] = logic 1), the $\overline{\text{TXRDY}}$ pin will be a logic 1 when the transmit FIFO is completely full. It will be a logic 0 when the trigger level has been reached.</p> <p>Receive operation in mode '1': When the SC16C654B/654DB is in FIFO mode (FCR[0] = logic 1; FCR[3] = logic 1) and the trigger level has been reached, or a Receive Time-Out has occurred, the $\overline{\text{RXRDY}}$ pin will go to a logic 0. Once activated, it will go to a logic 1 after there are no more characters in the FIFO.</p>
2	FCR[2]	<p>XMIT FIFO reset.</p> <p>logic 0 = no FIFO transmit reset (normal default condition)</p> <p>logic 1 = clears the contents of the transmit FIFO and resets the FIFO counter logic (the transmit shift register is not cleared or altered). This bit will return to a logic 0 after clearing the FIFO.</p>
1	FCR[1]	<p>RCVR FIFO reset.</p> <p>logic 0 = no FIFO receive reset (normal default condition)</p> <p>logic 1 = clears the contents of the receive FIFO and resets the FIFO counter logic (the receive shift register is not cleared or altered). This bit will return to a logic 0 after clearing the FIFO.</p>
0	FCR[0]	<p>FIFO enable.</p> <p>logic 0 = disable the transmit and receive FIFO (normal default condition)</p> <p>logic 1 = enable the transmit and receive FIFO. This bit must be a '1' when other FCR bits are written to, or they will not be programmed.</p>

Table 11: RX trigger levels

FCR[7]	FCR[6]	RX FIFO trigger level
0	0	08
0	1	16
1	0	56
1	1	60

Table 12: TX trigger levels

FCR[5]	FCR[4]	TX FIFO trigger level (# of characters)
0	0	08
0	1	16
1	0	32
1	1	56

7.4 Interrupt Status Register (ISR)

The SC16C654B/654DB provides six levels of prioritized interrupts to minimize external software interaction. The Interrupt Status Register (ISR) provides the user with six interrupt status bits. Performing a read cycle on the ISR will provide the user with the highest pending interrupt level to be serviced. No other interrupts are acknowledged until the pending interrupt is serviced. Whenever the interrupt status register is read, the interrupt status is cleared. However, it should be noted that only the current pending interrupt is cleared by the read. A lower level interrupt may be seen after re-reading the interrupt status bits. [Table 13 “Interrupt source”](#) shows the data values (bits 0:5) for the six prioritized interrupt levels and the interrupt sources associated with each of these interrupt levels.

Table 13: Interrupt source

Priority level	ISR[5]	ISR[4]	ISR[3]	ISR[2]	ISR[1]	ISR[0]	Source of the interrupt
1	0	0	0	1	1	0	LSR (Receiver Line Status Register)
2	0	0	0	1	0	0	RXRDY (Receive Data Ready)
2	0	0	1	1	0	0	RXRDY (Receive Data time-out)
3	0	0	0	0	1	0	TXRDY (Transmitter Holding Register Empty)
4	0	0	0	0	0	0	MSR (Modem Status Register)
5	0	1	0	0	0	0	RXRDY (Received Xoff signal)/Special character
6	1	0	0	0	0	0	CTS, RTS change of state

Table 14: Interrupt Status Register bits description

Bit	Symbol	Description
7:6	ISR[7:6]	FIFOs enabled. These bits are set to a logic 0 when the FIFO is not being used. They are set to a logic 1 when the FIFOs are enabled. logic 0 or cleared = default condition
5:4	ISR[5:4]	INT priority bits 4:3. These bits are enabled when EFR[4] is set to a logic 1. ISR[4] indicates that matching Xoff character(s) have been detected. ISR[5] indicates that CTS, RTS have been generated. Note that once set to a logic 1, the ISR[4] bit will stay a logic 1 until Xon character(s) are received. logic 0 or cleared = default condition
3:1	ISR[3:1]	INT priority bits 2:0. These bits indicate the source for a pending interrupt at interrupt priority levels 1, 2, and 3; see Table 13 . Logic 0 or cleared = default condition.
0	ISR[0]	INT status. logic 0 = an interrupt is pending and the ISR contents may be used as a pointer to the appropriate interrupt service routine logic 1 = no interrupt pending (normal default condition)

7.5 Line Control Register (LCR)

The Line Control Register is used to specify the asynchronous data communication format. The word length, the number of stop bits, and the parity are selected by writing the appropriate bits in this register.

Table 15: Line Control Register bits description

Bit	Symbol	Description
7	LCR[7]	Divisor latch enable. The internal baud rate counter latch and Enhance Feature mode enable. logic 0 = divisor latch disabled (normal default condition) logic 1 = divisor latch and enhanced feature register enabled
6	LCR[6]	Set break. When enabled, the Break control bit causes a break condition to be transmitted (the TX output is forced to a logic 0 state). This condition exists until disabled by setting LCR[6] to a logic 0. logic 0 = no TX break condition (normal default condition) logic 1 = forces the transmitter output (TX) to a logic 0 for alerting the remote receiver to a line break condition
5	LCR[5]	Set parity. If the parity bit is enabled, LCR[5] selects the forced parity format. Programs the parity conditions; see Table 16 . logic 0 = parity is not forced (normal default condition) LCR[5] = logic 1 and LCR[4] = logic 0: parity bit is forced to a logical 1 for the transmit and receive data LCR[5] = logic 1 and LCR[4] = logic 1: parity bit is forced to a logical 0 for the transmit and receive data
4	LCR[4]	Even parity. If the parity bit is enabled with LCR[3] set to a logic 1, LCR[4] selects the even or odd parity format. logic 0 = odd parity is generated by forcing an odd number of logic 1s in the transmitted data. The receiver must be programmed to check the same format (normal default condition). logic 1 = even parity is generated by forcing an even number of logic 1s in the transmitted data. The receiver must be programmed to check the same format.
3	LCR[3]	Parity enable. Parity or no parity can be selected via this bit. logic 0 = no parity (normal default condition) logic 1 = a parity bit is generated during the transmission, receiver checks the data and parity for transmission errors
2	LCR[2]	Stop bits. The length of stop bit is specified by this bit in conjunction with the programmed word length; see Table 17 . logic 0 or cleared = default condition
1:0	LCR[1:0]	Word length bits 1, 0. These two bits specify the word length to be transmitted or received; see Table 18 . logic 0 or cleared = default condition

Table 16: LCR[5] parity selection

LCR[5]	LCR[4]	LCR[3]	Parity selection
X	X	0	no parity
0	0	1	odd parity
0	1	1	even parity
1	0	1	forced parity '1'
1	1	1	forced parity '0'

Table 17: LCR[2] stop bit length

LCR[2]	Word length	Stop bit length (bit times)
0	5, 6, 7, 8	1
1	5	1½
1	6, 7, 8	2

Table 18: LCR[1:0] word length

LCR[1]	LCR[0]	Word length
0	0	5
0	1	6
1	0	7
1	1	8

7.6 Modem Control Register (MCR)

This register controls the interface with the modem or a peripheral device.

Table 19: Modem Control Register bits description

Bit	Symbol	Description
7	MCR[7]	<p>Clock select.</p> <p>logic 0 = divide-by-1. The input clock (crystal or external) is divided by 16 and then presented to the Programmable Baud Rate Generator (BGR) without further modification, that is, divide-by-1. (normal default condition).</p> <p>logic 1 = divide-by-4. The divide-by-1 clock described in MCR[7] = a logic 0, if further divided by four. Also see Section 6.9 “Programmable baud rate generator”.</p>
6	MCR[6]	<p>IR enable.</p> <p>logic 0 = enable the standard modem receive and transmit input/output interface (normal default condition)</p> <p>logic 1 = enable infrared IrDA receive and transmit inputs/outputs. While in this mode, the TX/RX output/inputs are routed to the infrared encoder/decoder. The data input and output levels will conform to the IrDA infrared interface requirement. As such, while in this mode, the infrared TX output will be a logic 0 during idle data conditions.</p>
5	MCR[5]	<p>Xon Any.</p> <p>logic 0 = disable Xon Any function (for 16C554 compatibility) (normal default condition)</p> <p>logic 1 = enable Xon Any function. In this mode, any RX character received will enable Xon</p>

Table 19: Modem Control Register bits description ...continued

Bit	Symbol	Description
4	MCR[4]	<p>Loop-back. Enable the local loop-back mode (diagnostics). In this mode the transmitter output (TX) and the receiver input (RX), CTS, DSR, CD, and RI are disconnected from the SC16C654B/654DB I/O pins. Internally the modem data and control pins are connected into a loop-back data configuration; see Figure 12. In this mode, the receiver and transmitter interrupts remain fully operational. The Modem Control Interrupts are also operational, but the interrupts' sources are switched to the lower four bits of the Modem Control. Interrupts continue to be controlled by the IER register.</p> <p>logic 0 = disable loop-back mode (normal default condition) logic 1 = enable local loop-back mode (diagnostics)</p>
3	MCR[3]	<p>OP2, INTx enable. Used to control the modem CD signal in the loop-back mode.</p> <p>logic 0 = forces INTA-INTD outputs to the 3-state mode during the 16 mode (normal default condition). In the loop-back mode, sets OP2 (CD) internally to a logic 1.</p> <p>logic 1 = forces the INTA-INTD outputs to the active mode during the 16 mode. In the loop-back mode, sets OP2 (CD) internally to a logic 0.</p>
2	MCR[2]	<p>OP1. This bit is used in the Loop-back mode only. In the loop-back mode, this bit is used to write the state of the modem RI interface signal via OP1.</p>
1	MCR[1]	<p>RTS</p> <p>logic 0 = force RTS output to a logic 1 (normal default condition) logic 1 = force RTS output to a logic 0</p> <p>Automatic RTS may be used for hardware flow control by enabling EFR[6]. See Table 22.</p>
0	MCR[0]	<p>DTR</p> <p>logic 0 = force DTR output to a logic 1 (normal default condition) logic 1 = force DTR output to a logic 0</p>

7.7 Line Status Register (LSR)

This register provides the status of data transfers between the SC16C654B/654DB and the CPU.

Table 20: Line Status Register bits description

Bit	Symbol	Description
7	LSR[7]	FIFO data error. logic 0 = no error (normal default condition) logic 1 = at least one parity error, framing error or break indication is in the current FIFO data. This bit is cleared when LSR register is read.
6	LSR[6]	THR and TSR empty. This bit is the Transmit Empty indicator. This bit is set to a logic 1 whenever the transmit holding register and the transmit shift register are both empty. It is reset to logic 0 whenever either the THR or TSR contains a data character. In the FIFO mode, this bit is set to '1' whenever the transmit FIFO and transmit shift register are both empty.
5	LSR[5]	THR empty. This bit is the Transmit Holding Register Empty indicator. This bit indicates that the UART is ready to accept a new character for transmission. In addition, this bit causes the UART to issue an interrupt to CPU when the THR interrupt enable is set. The THR bit is set to a logic 1 when a character is transferred from the transmit holding register into the transmitter shift register. The bit is reset to a logic 0 concurrently with the loading of the transmitter holding register by the CPU. In the FIFO mode, this bit is set when the transmit FIFO is empty; it is cleared when at least 1 byte is written to the transmit FIFO.
4	LSR[4]	Break interrupt. logic 0 = no break condition (normal default condition) logic 1 = the receiver received a break signal (RX was a logic 0 for one character frame time). In the FIFO mode, only one break character is loaded into the FIFO.
3	LSR[3]	Framing error. logic 0 = no framing error (normal default condition) logic 1 = framing error. The receive character did not have a valid stop bit(s). In the FIFO mode, this error is associated with the character at the top of the FIFO.
2	LSR[2]	Parity error. logic 0 = no parity error (normal default condition) logic 1 = parity error. The receive character does not have correct parity information and is suspect. In the FIFO mode, this error is associated with the character at the top of the FIFO.
1	LSR[1]	Overrun error. logic 0 = no overrun error (normal default condition) logic 1 = overrun error. A data overrun error occurred in the receive shift register. This happens when additional data arrives while the FIFO is full. In this case, the previous data in the shift register is overwritten. Note that under this condition, the data byte in the receive shift register is not transferred into the FIFO, therefore the data in the FIFO is not corrupted by the error.
0	LSR[0]	Receive data ready. logic 0 = no data in receive holding register or FIFO (normal default condition) logic 1 = data has been received and is saved in the receive holding register or FIFO

7.8 Modem Status Register (MSR)

This register provides the current state of the control interface signals from the modem, or other peripheral device to which the SC16C654B/654DB is connected. Four bits of this register are used to indicate the changed information. These bits are set to a logic 1 whenever a control input from the modem changes state. These bits are set to a logic 0 whenever the CPU reads this register.

Table 21: Modem Status Register bits description

Bit	Symbol	Description
7	MSR[7]	CD (active HIGH, logical 1). Normally this bit is the complement of the \overline{CD} input. In the loop-back mode this bit is equivalent to the $\overline{OP2}$ bit in the MCR register.
6	MSR[6]	RI (active HIGH, logical 1). Normally this bit is the complement of the \overline{RI} input. In the loop-back mode this bit is equivalent to the $\overline{OP1}$ bit in the MCR register.
5	MSR[5]	DSR (active HIGH, logical 1). Normally this bit is the complement of the \overline{DSR} input. In loop-back mode this bit is equivalent to the DTR bit in the MCR register.
4	MSR[4]	CTS. \overline{CTS} functions as hardware flow control signal input if it is enabled via EFR[7]. The transmit holding register flow control is enabled/disabled by MSR[4]. Flow control (when enabled) allows starting and stopping the transmissions based on the external modem \overline{CTS} signal. A logic 1 at the \overline{CTS} pin will stop SC16C654B/654DB transmissions as soon as current character has finished transmission. Normally MSR[4] is the complement of the \overline{CTS} input. However, in the loop-back mode, this bit is equivalent to the \overline{RTS} bit in the MCR register.
3	MSR[3]	$\Delta\overline{CD}$ [1] logic 0 = no \overline{CD} change (normal default condition) logic 1 = the \overline{CD} input to the SC16C654B/654DB has changed state since the last time it was read. A modem Status Interrupt will be generated.
2	MSR[2]	$\Delta\overline{RI}$ [1] logic 0 = no \overline{RI} change (normal default condition) logic 1 = the \overline{RI} input to the SC16C654B/654DB has changed from a logic 0 to a logic 1. A modem Status Interrupt will be generated.
1	MSR[1]	$\Delta\overline{DSR}$ [1] logic 0 = no \overline{DSR} change (normal default condition) logic 1 = the \overline{DSR} input to the SC16C654B/654DB has changed state since the last time it was read. A Modem Status Interrupt will be generated.
0	MSR[0]	$\Delta\overline{CTS}$ [1] logic 0 = no \overline{CTS} change (normal default condition) logic 1 = the \overline{CTS} input to the SC16C654B/654DB has changed state since the last time it was read. A Modem Status Interrupt will be generated.

[1] Whenever any MSR bit 0:3 is set to logic 1, a Modem Status Interrupt will be generated.

7.9 Scratchpad Register (SPR)

The SC16C654B/654DB provides a temporary data register to store 8 bits of user information.

7.10 Enhanced Feature Register (EFR)

Enhanced features are enabled or disabled using this register.

Bits 0 through 4 provide single or dual character software flow control selection. When the Xon1 and Xon2 and/or Xoff1 and Xoff2 modes are selected, the double 8-bit words are concatenated into two sequential numbers.

Table 22: Enhanced Feature Register bits description

Bit	Symbol	Description
7	EFR[7]	Auto CTS. Automatic CTS Flow Control. logic 0 = automatic CTS flow control is disabled (normal default condition) logic 1 = enable Automatic CTS flow control. Transmission will stop when CTS goes to a logical 1. Transmission will resume when the CTS pin returns to a logical 0.
6	EFR[6]	Auto RTS. Automatic RTS may be used for hardware flow control by enabling EFR[6]. When Auto RTS is selected, an interrupt will be generated when the receive FIFO is filled to the programmed trigger level and RTS will go to a logic 1 at the next trigger level. RTS will return to a logic 0 when data is unloaded below the next lower trigger level. The state of this register bit changes with the status of the hardware flow control. RTS functions normally when hardware flow control is disabled. logic 0 = automatic RTS flow control is disabled (normal default condition) logic 1 = enable Automatic RTS flow control
5	EFR[5]	Special Character Detect. logic 0 = special character detect disabled (normal default condition) logic 1 = special character detect enabled. The SC16C654B/654DB compares each incoming receive character with Xoff2 data. If a match exists, the received data will be transferred to FIFO and ISR[4] will be set to indicate detection of special character. Bit-0 in the X-registers corresponds with the LSB bit for the receive character. When this feature is enabled, the normal software flow control must be disabled (EFR[3:0] must be set to a logic 0).
4	EFR[4]	Enhanced function control bit. The content of IER[7:4], ISR[5:4], FCR[5:4], and MCR[7:5] can be modified and latched. After modifying any bits in the enhanced registers, EFR[4] can be set to a logic 0 to latch the new values. This feature prevents existing software from altering or overwriting the SC16C654B/654DB enhanced functions. logic 0 = disable (normal default condition) logic 1 = enable
3:0	EFR[3:0]	Cont-3:0 Tx, Rx control. Logic 0 or cleared is the default condition. Combinations of software flow control can be selected by programming these bits. See Table 23 .

Table 23: Software flow control functions [1]

Cont-3	Cont-2	Cont-1	Cont-0	TX, RX software flow controls
0	0	X	X	no transmit flow control
1	0	X	X	transmit Xon1/Xoff1
0	1	X	X	transmit Xon2/Xoff2
1	1	X	X	transmit Xon1 and Xon2/Xoff1 and Xoff2
X	X	0	0	no receive flow control
X	X	1	0	receiver compares Xon1/Xoff1
X	X	0	1	receiver compares Xon2/Xoff2
1	0	1	1	transmit Xon1/Xoff1 receiver compares Xon1 and Xon2, Xoff1 and Xoff2
0	1	1	1	transmit Xon2/Xoff2 receiver compares Xon1 and Xon2/Xoff1 and Xoff2
1	1	1	1	transmit Xon1 and Xon2/Xoff1 and Xoff2 receiver compares Xon1 and Xon2/Xoff1 and Xoff2

[1] When using software flow control the Xon/Xoff characters cannot be used for data transfer.

7.11 SC16C654B/654DB external reset conditions

Table 24: Reset state for registers

Register	Reset state
IER	IER[7:0] = 0
ISR	ISR[7:1] = 0; ISR[0] = 1
LCR	LCR[7:0] = 0
MCR	MCR[7:0] = 0
LSR	LSR[7] = 0; LSR[6:5] = 1; LSR[4:0] = 0
MSR	MSR[7:4] = input signals; MSR[3:0] = 0
FCR	FCR[7:0] = 0
EFR	EFR[7:0] = 0

Table 25: Reset state for outputs

Output	Reset state
TXA, TXB, TXC, TXD	HIGH
RTSA, RTSB, RTSC, RTSD	HIGH
DTRA, DTRB, DTRC, DTRD	HIGH
RXRDY	HIGH
TXRDY	LOW

8. Limiting values

Table 26: Limiting values

In accordance with the Absolute Maximum Rating System (IEC 60134).

Symbol	Parameter	Conditions	Min	Max	Unit
V_{CC}	supply voltage		-	7	V
V_n	voltage at any pin		GND – 0.3	$V_{CC} + 0.3$	V
T_{amb}	ambient temperature		–40	+85	°C
T_{stg}	storage temperature		–65	+150	°C
$P_{tot(pack)}$	total power dissipation per package		-	500	mW

9. Static characteristics

Table 27: Static characteristics $T_{amb} = -40^{\circ}\text{C}$ to $+85^{\circ}\text{C}$; tolerance of $V_{CC} = \pm 10\%$, unless otherwise specified.

Symbol	Parameter	Conditions	$V_{CC} = 2.5\text{ V}$			$V_{CC} = 3.3\text{ V}$			$V_{CC} = 5.0\text{ V}$			Unit
			Min	Typ	Max	Min	Typ	Max	Min	Typ	Max	
$V_{IL(CK)}$	LOW-level clock input voltage		-0.3	-	0.45	-0.3	-	0.6	-0.5	-	0.6	V
$V_{IH(CK)}$	HIGH-level clock input voltage		1.8	-	V_{CC}	2.4	-	V_{CC}	3.0	-	V_{CC}	V
V_{IL}	LOW-level input voltage (except XTAL1 clock)		-0.3	-	0.65	-0.3	-	0.8	-0.5	-	0.8	V
V_{IH}	HIGH-level input voltage (except XTAL1 clock)		1.6	-	-	2.0	-	-	2.2	-	-	V
V_{OL}	LOW-level output voltage on all outputs [1]	$I_{OL} = 5\text{ mA}$ (data bus)	-	-	-	-	-	-	-	-	0.4	V
		$I_{OL} = 4\text{ mA}$ (other outputs)	-	-	-	-	-	0.4	-	-	-	V
		$I_{OL} = 2\text{ mA}$ (data bus)	-	-	0.4	-	-	-	-	-	-	V
		$I_{OL} = 1.6\text{ mA}$ (other outputs)	-	-	0.4	-	-	-	-	-	-	V
V_{OH}	HIGH-level output voltage	$I_{OH} = -5\text{ mA}$ (data bus)	-	-	-	-	-	-	2.4	-	-	V
		$I_{OH} = -1\text{ mA}$ (other outputs)	-	-	-	2.0	-	-	-	-	-	V
		$I_{OH} = -800\text{ }\mu\text{A}$ (data bus)	1.85	-	-	-	-	-	-	-	-	V
		$I_{OH} = -400\text{ }\mu\text{A}$ (other outputs)	1.85	-	-	-	-	-	-	-	-	V
I_{LIL}	LOW-level input leakage current		-	-	± 10	-	-	± 10	-	-	± 10	μA
I_{CL}	clock leakage		-	-	± 30	-	-	± 30	-	-	± 30	μA
I_{CC}	supply current	$f = 5\text{ MHz}$	-	-	4.5	-	-	6	-	-	6	mA
$I_{CC\text{sleep}}$	sleep current [2]		-	200	-	-	200	-	-	200	-	μA
C_i	input capacitance		-	-	5	-	-	5	-	-	5	pF
$R_{\text{pu(int)}}$	internal pull-up resistance [3]		500	-	-	500	-	-	500	-	-	$\text{k}\Omega$

[1] Except XTAL2, $V_{OL} = 1\text{ V}$ typical.

[2] When using crystal oscillator. The use of an external clock will increase the sleep current.

[3] Refer to [Table 2 "Pin description" on page 10](#) for a listing of pins having internal pull-up resistors.

10. Dynamic characteristics

Table 28: Dynamic characteristics

$T_{amb} = -40^{\circ}\text{C}$ to $+85^{\circ}\text{C}$; tolerance of $V_{CC} = \pm 10\%$, unless otherwise specified.

Symbol	Parameter	Conditions	$V_{CC} = 2.5\text{ V}$		$V_{CC} = 3.3\text{ V}$		$V_{CC} = 5.0\text{ V}$		Unit
			Min	Max	Min	Max	Min	Max	
t_{1w}, t_{2w}	clock pulse duration		10	-	6	-	6	-	ns
f_{XTAL}	oscillator/clock frequency	[1] [2]	-	48	-	80	-	80	MHz
t_{6s}	address setup time		0	-	0	-	0	-	ns
t_{6h}	address hold time		0	-	0	-	0	-	ns
t_{7d}	$\overline{\text{IOR}}$ delay from chip select		10	-	10	-	10	-	ns
t_{7w}	$\overline{\text{IOR}}$ strobe width	25 pF load	77	-	26	-	23	-	ns
t_{7h}	chip select hold time from $\overline{\text{IOR}}$		0	-	0	-	0	-	ns
t_{9d}	read cycle delay	25 pF load	20	-	20	-	20	-	ns
t_{12d}	delay from $\overline{\text{IOR}}$ to data	25 pF load	-	77	-	26	-	23	ns
t_{12h}	data disable time	25 pF load	-	15	-	15	-	15	ns
t_{13d}	$\overline{\text{IOW}}$ delay from chip select		10	-	10	-	10	-	ns
t_{13w}	$\overline{\text{IOW}}$ strobe width		20	-	20	-	15	-	ns
t_{13h}	chip select hold time from $\overline{\text{IOW}}$		0	-	0	-	0	-	ns
t_{15d}	write cycle delay		25	-	25	-	20	-	ns
t_{16s}	data setup time		20	-	20	-	15	-	ns
t_{16h}	data hold time		15	-	5	-	5	-	ns
t_{17d}	delay from $\overline{\text{IOW}}$ to output	25 pF load	-	100	-	33	-	29	ns
t_{18d}	delay to set interrupt from Modem input	25 pF load	-	100	-	24	-	23	ns
t_{19d}	delay to reset interrupt from $\overline{\text{IOR}}$	25 pF load	-	100	-	24	-	23	ns
t_{20d}	delay from stop to set interrupt		-	$1T_{RCLK}$ [3]	-	$1T_{RCLK}$ [3]	-	$1T_{RCLK}$ [3]	ns
t_{21d}	delay from $\overline{\text{IOR}}$ to reset interrupt	25 pF load	-	100	-	29	-	28	ns
t_{22d}	delay from start to set interrupt		-	100	-	45	-	40	ns
t_{23d}	delay from $\overline{\text{IOW}}$ to transmit start		$8T_{RCLK}$ [3]	$24T_{RCLK}$ [3]	$8T_{RCLK}$ [3]	$24T_{RCLK}$ [3]	$8T_{RCLK}$ [3]	$24T_{RCLK}$ [3]	ns
t_{24d}	delay from $\overline{\text{IOW}}$ to reset interrupt		-	100	-	45	-	40	ns
t_{25d}	delay from stop to set $\overline{\text{RXRDY}}$		-	$1T_{RCLK}$ [3]	-	$1T_{RCLK}$ [3]	-	$1T_{RCLK}$ [3]	ns
t_{26d}	delay from $\overline{\text{IOR}}$ to reset $\overline{\text{RXRDY}}$		-	100	-	45	-	40	ns
t_{27d}	delay from $\overline{\text{IOW}}$ to set $\overline{\text{TXRDY}}$		-	100	-	45	-	40	ns

Table 28: Dynamic characteristics ...continued

$T_{amb} = -40^{\circ}\text{C}$ to $+85^{\circ}\text{C}$; tolerance of $V_{CC} = \pm 10\%$, unless otherwise specified.

Symbol	Parameter	Conditions	$V_{CC} = 2.5\text{ V}$		$V_{CC} = 3.3\text{ V}$		$V_{CC} = 5.0\text{ V}$		Unit
			Min	Max	Min	Max	Min	Max	
t_{28d}	delay from start to reset TXRDY		-	$8T_{RCLK}$ [3]	-	$8T_{RCLK}$ [3]	-	$8T_{RCLK}$ [3]	ns
t_{30s}	address setup time		10	-	10	-	10	-	ns
t_{30w}	chip select strobe width	25 pF load	[1] 90	-	26	-	23	-	ns
t_{30h}	address hold time		15	-	15	-	15	-	ns
t_{30d}	read cycle delay	25 pF load	20	-	20	-	20	-	ns
t_{31d}	delay from \overline{CS} to data	25 pF load	-	90	-	26	-	23	ns
t_{31h}	data disable time	25 pF load	-	15	-	15	-	15	ns
t_{32s}	write strobe setup time		10	-	10	-	10	-	ns
t_{32h}	write strobe hold time		10	-	10	-	10	-	ns
t_{32d}	write cycle delay		25	-	25	-	20	-	ns
t_{33s}	data setup time		20	-	15	-	15	-	ns
t_{33h}	data hold time		15	-	5	-	5	-	ns
t_{RESET}	RESET pulse width		200	-	40	-	40	-	ns
N	baud rate divisor		1	$(2^{16} - 1)$	1	$(2^{16} - 1)$	1	$(2^{16} - 1)$	

[1] Applies to external clock, crystal oscillator max 24 MHz.

[2] Maximum frequency = $\frac{1}{t_{3w}}$

[3] RCLK is an internal signal derived from Divisor Latch LSB (DLL) and Divisor Latch MSB (DLM) divisor latches.

10.1 Timing diagrams



Fig 13. General read timing in 68 mode



Fig 14. General write timing in 68 mode

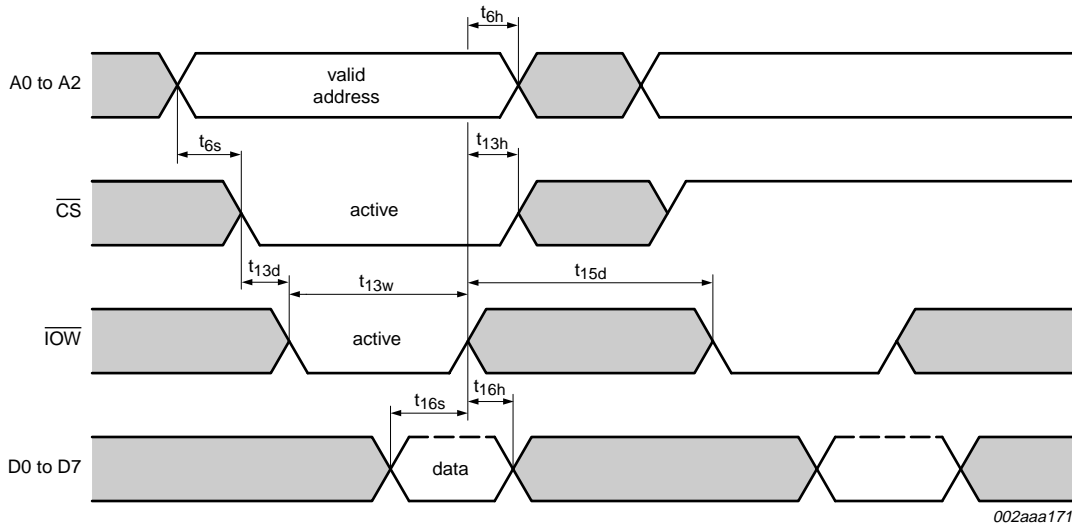

Fig 15. General write timing in 16 mode

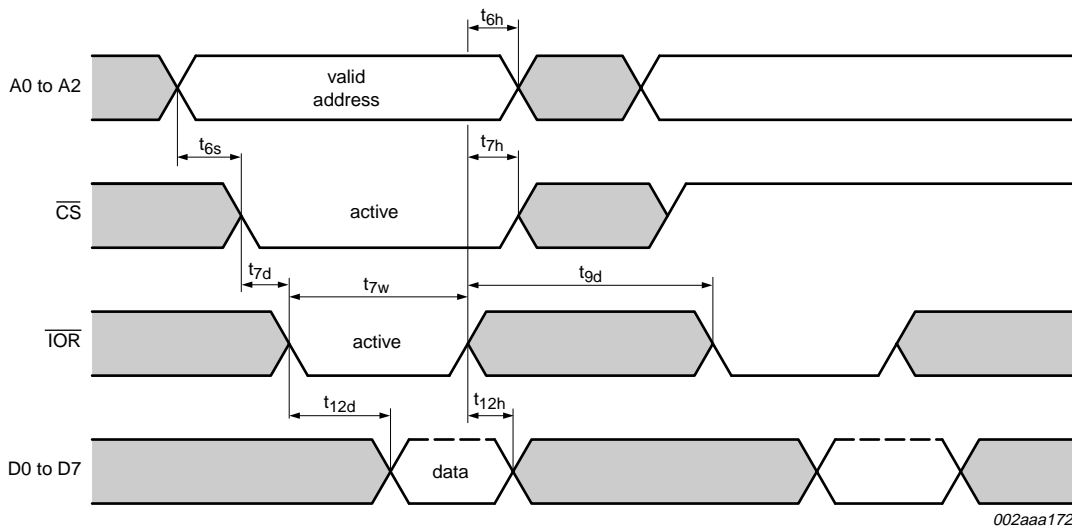

Fig 16. General read timing in 16 mode

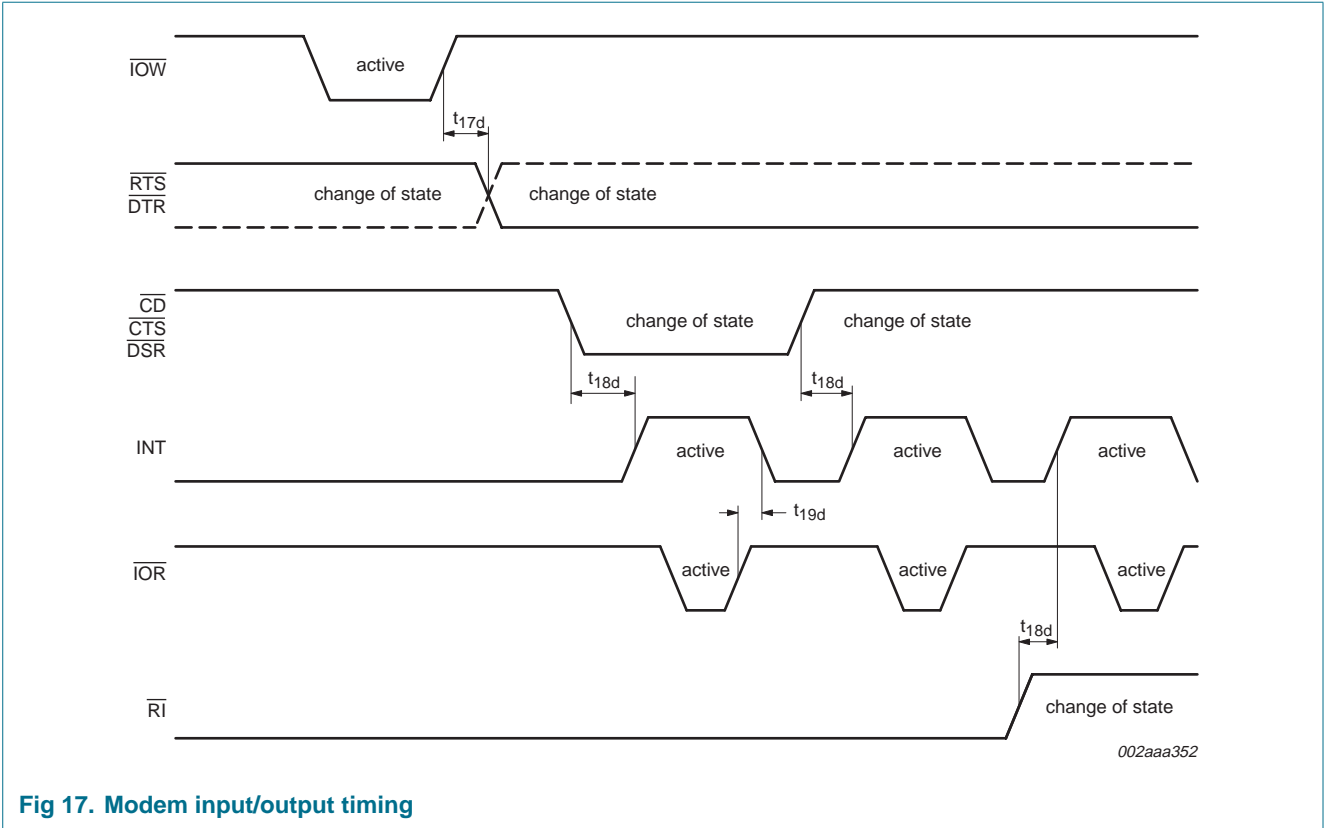

Fig 17. Modem input/output timing

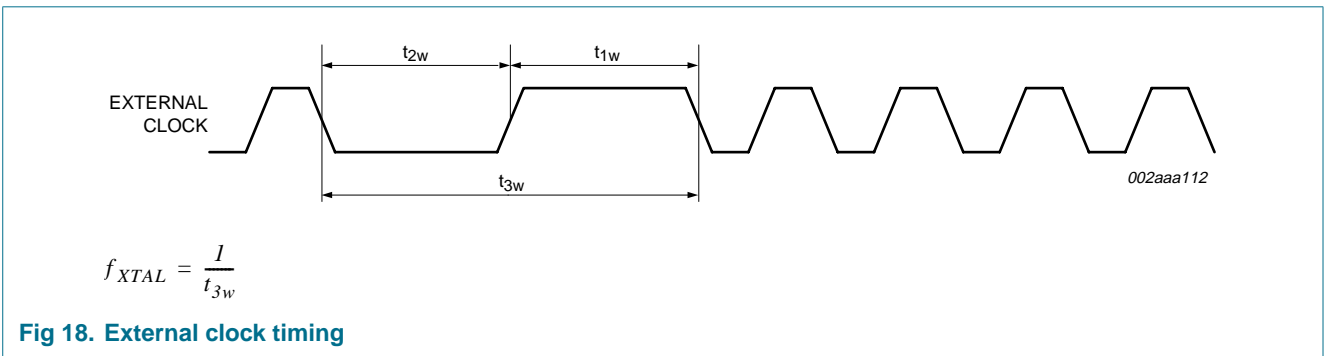

Fig 18. External clock timing



Fig 19. Receive timing



Fig 20. Receive ready timing in non-FIFO mode

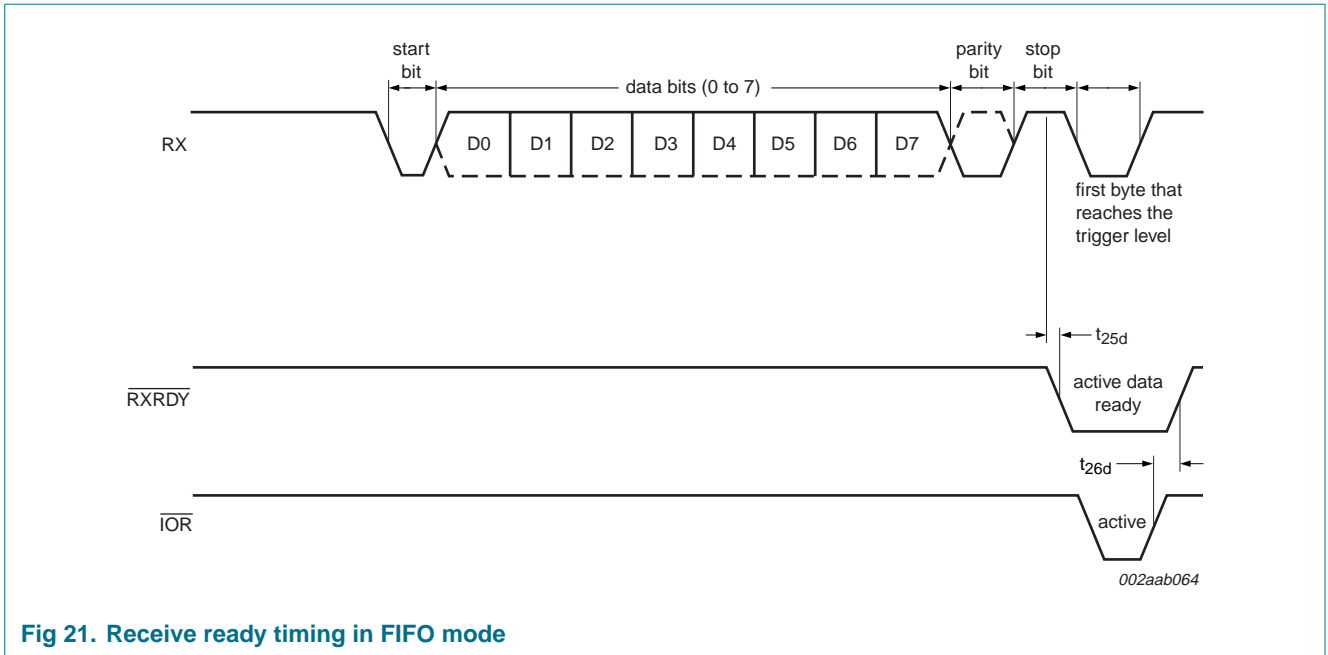

Fig 21. Receive ready timing in FIFO mode

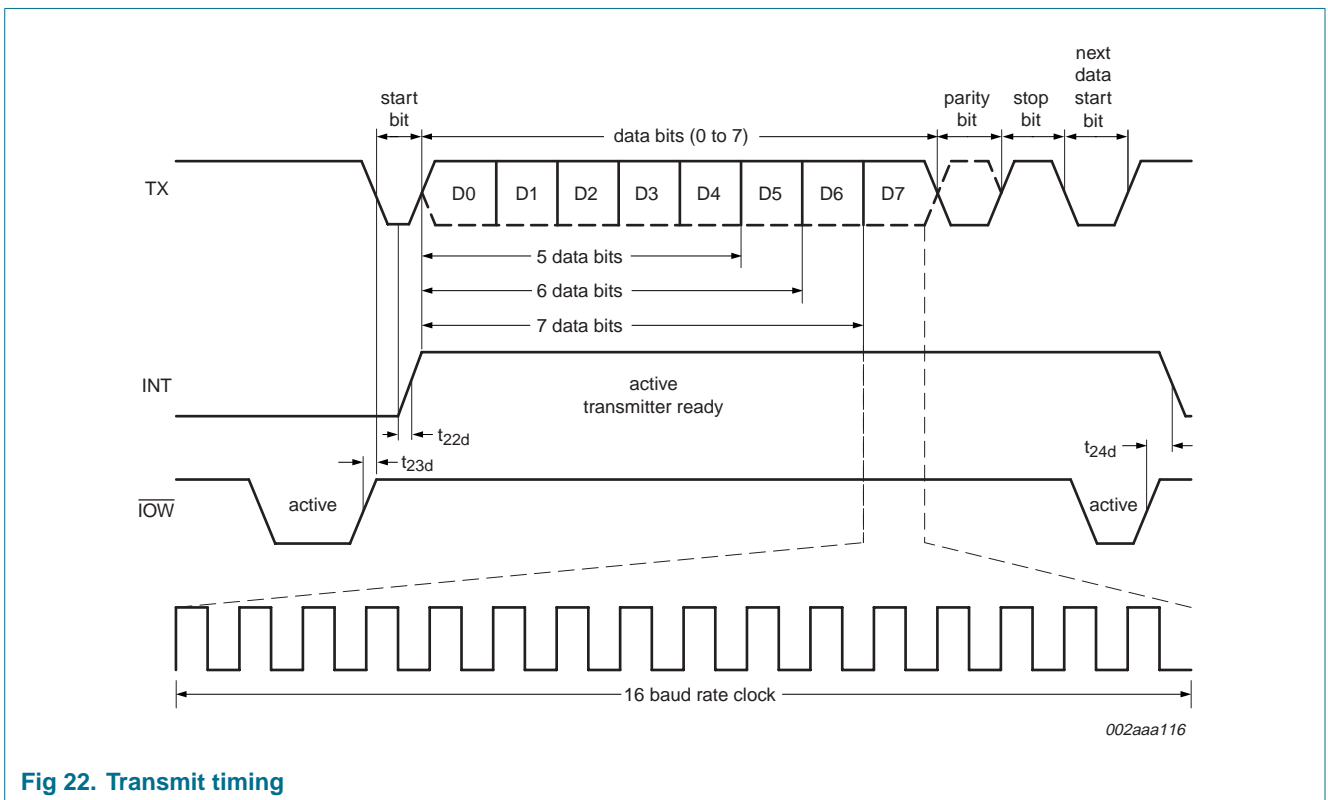
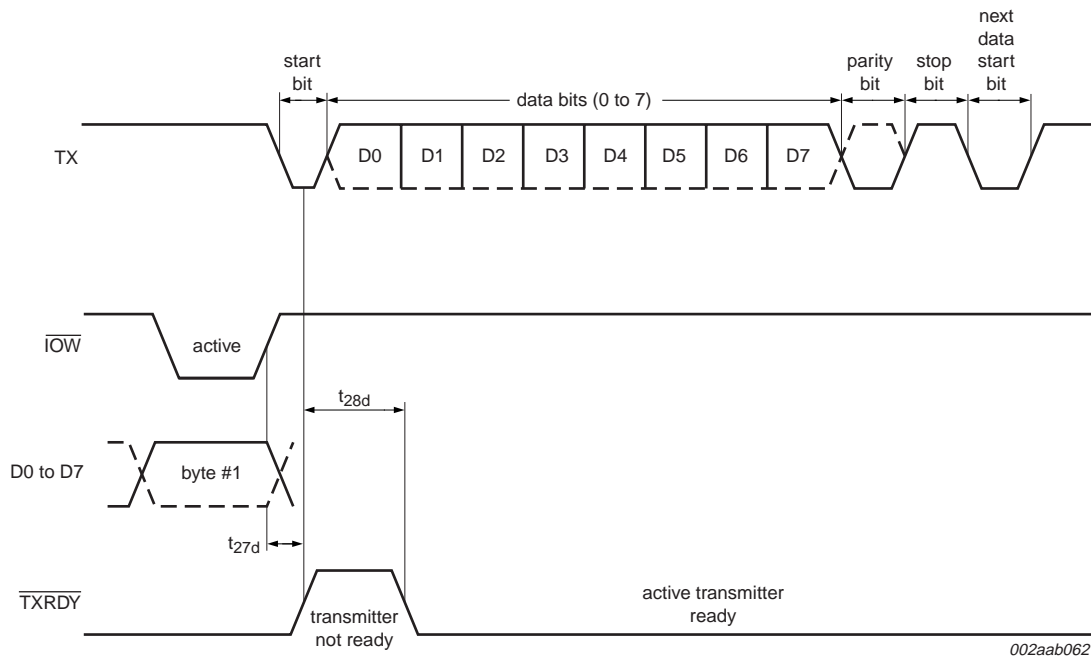
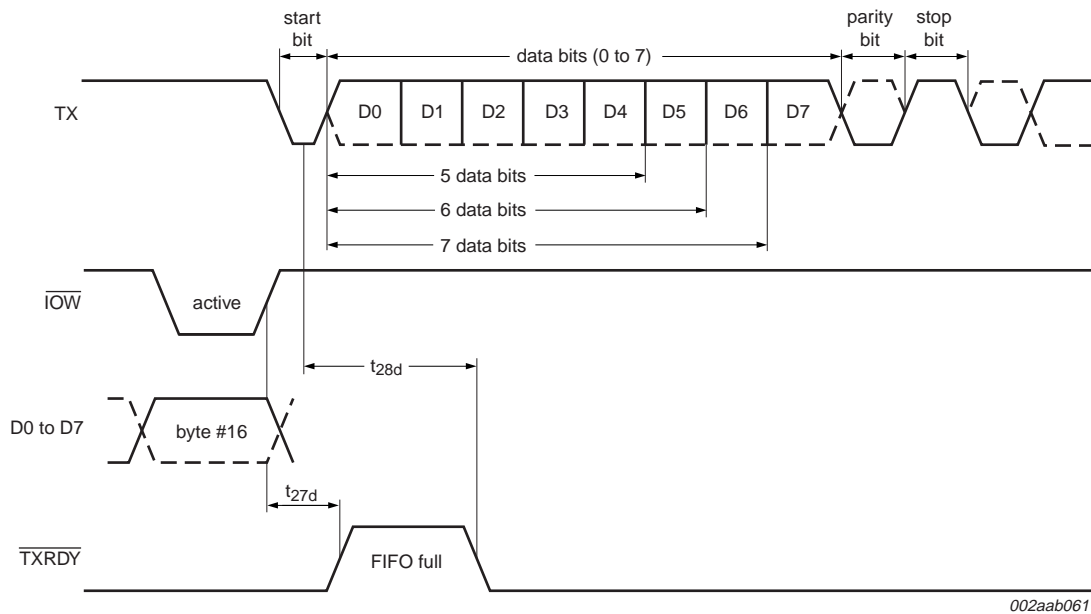

Fig 22. Transmit timing



002aab062

Fig 23. Transmit ready timing in non-FIFO mode



002aab061

Fig 24. Transmit ready timing in FIFO mode (DMA mode '1')

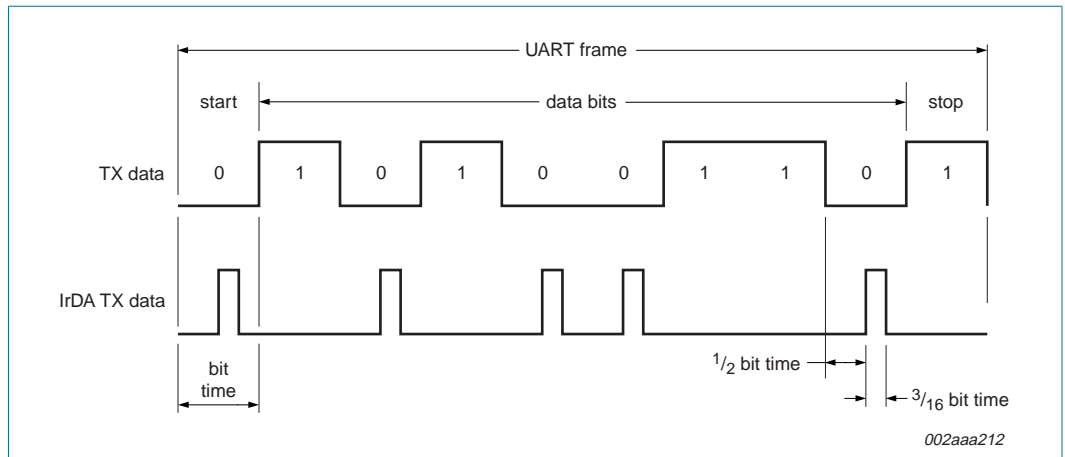

Fig 25. Infrared transmit timing

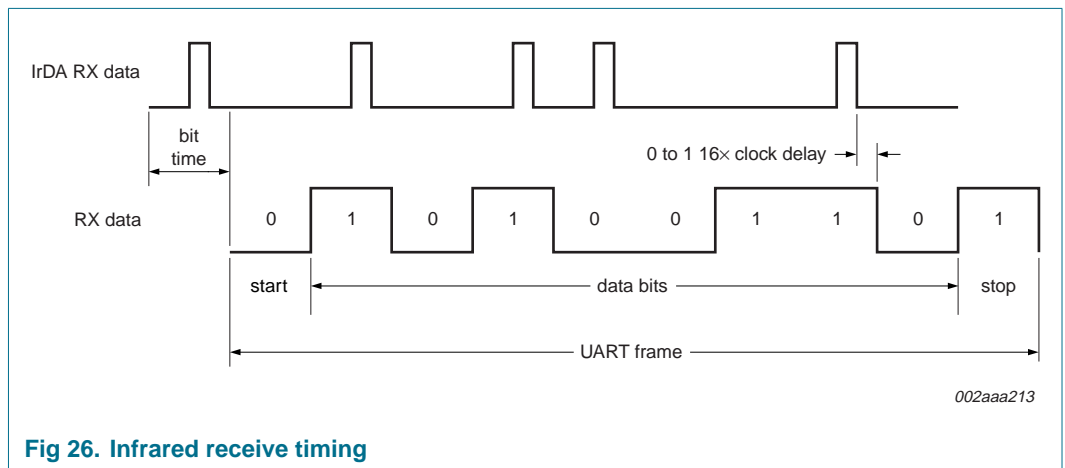

Fig 26. Infrared receive timing

11. Package outline

PLCC68: plastic leaded chip carrier; 68 leads

SOT188-2

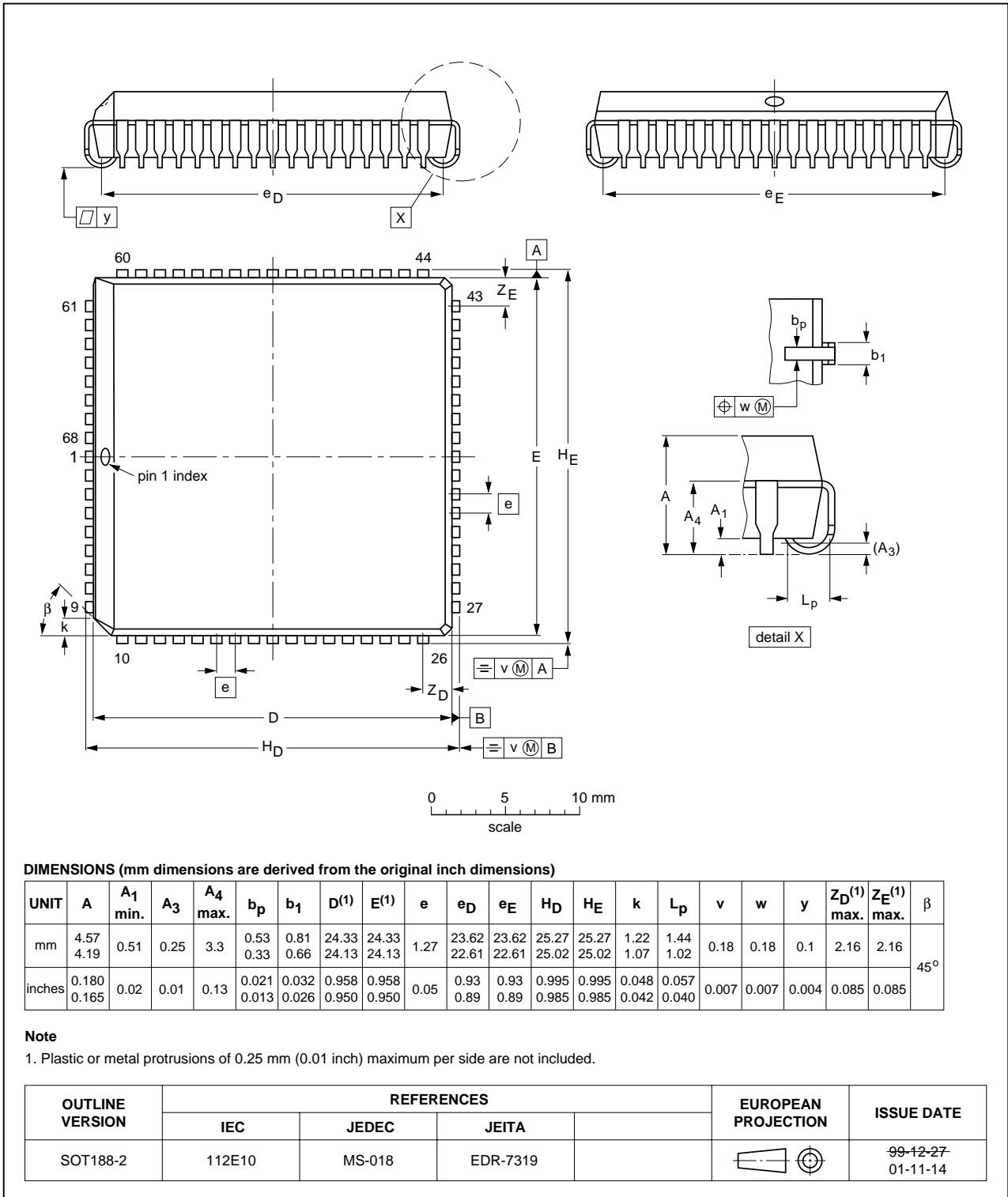

Fig 27. Package outline SOT188-2 (PLCC68)

LQFP64: plastic low profile quad flat package; 64 leads; body 10 x 10 x 1.4 mm

SOT314-2



Fig 28. Package outline SOT314-2 (LQFP64)

LQFP64: plastic low profile quad flat package; 64 leads; body 7 x 7 x 1.4 mm

SOT414-1



Fig 29. Package outline SOT414-1 (LQFP64)

HVQFN48: plastic thermal enhanced very thin quad flat package; no leads;
48 terminals; body 6 x 6 x 0.85 mm

SOT778-3



DIMENSIONS (mm are the original dimensions)

UNIT	A ⁽¹⁾ max	A ₁	b	c	D ⁽¹⁾	D _h	E ⁽¹⁾	E _h	e	e ₁	e ₂	L	v	w	y	y ₁
mm	1	0.05 0.00	0.25 0.15	0.2	6.1 5.9	3.95 3.65	6.1 5.9	3.95 3.65	0.4	4.4	4.4	0.5 0.3	0.1	0.05	0.05	0.1

Note

1. Plastic or metal protrusions of 0.075 mm maximum per side are not included

OUTLINE VERSION	REFERENCES				EUROPEAN PROJECTION	ISSUE DATE
	IEC	JEDEC	JEITA			
SOT778-3	---	---	---			04-06-16 04-06-23

Fig 30. Package outline SOT778-3 (HVQFN48)

LFBGA64: plastic low profile fine-pitch ball grid array package; 64 balls; body 6 x 6 x 1.05 mm

SOT686-1



Fig 31. Package outline SOT686-1 (LFBGA64)

12. Soldering

12.1 Introduction to soldering surface mount packages

This text gives a very brief insight to a complex technology. A more in-depth account of soldering ICs can be found in our *Data Handbook IC26; Integrated Circuit Packages* (document order number 9398 652 90011).

There is no soldering method that is ideal for all surface mount IC packages. Wave soldering can still be used for certain surface mount ICs, but it is not suitable for fine pitch SMDs. In these situations reflow soldering is recommended.

12.2 Reflow soldering

Reflow soldering requires solder paste (a suspension of fine solder particles, flux and binding agent) to be applied to the printed-circuit board by screen printing, stencilling or pressure-syringe dispensing before package placement. Driven by legislation and environmental forces the worldwide use of lead-free solder pastes is increasing.

Several methods exist for reflowing; for example, convection or convection/infrared heating in a conveyor type oven. Throughput times (preheating, soldering and cooling) vary between 100 seconds and 200 seconds depending on heating method.

Typical reflow peak temperatures range from 215 °C to 270 °C depending on solder paste material. The top-surface temperature of the packages should preferably be kept:

- below 225 °C (SnPb process) or below 245 °C (Pb-free process)
 - for all BGA, HTSSON..T and SSOP..T packages
 - for packages with a thickness ≥ 2.5 mm
 - for packages with a thickness < 2.5 mm and a volume ≥ 350 mm³ so called thick/large packages.
- below 240 °C (SnPb process) or below 260 °C (Pb-free process) for packages with a thickness < 2.5 mm and a volume < 350 mm³ so called small/thin packages.

Moisture sensitivity precautions, as indicated on packing, must be respected at all times.

12.3 Wave soldering

Conventional single wave soldering is not recommended for surface mount devices (SMDs) or printed-circuit boards with a high component density, as solder bridging and non-wetting can present major problems.

To overcome these problems the double-wave soldering method was specifically developed.

If wave soldering is used the following conditions must be observed for optimal results:

- Use a double-wave soldering method comprising a turbulent wave with high upward pressure followed by a smooth laminar wave.
- For packages with leads on two sides and a pitch (e):
 - larger than or equal to 1.27 mm, the footprint longitudinal axis is **preferred** to be parallel to the transport direction of the printed-circuit board;

- smaller than 1.27 mm, the footprint longitudinal axis **must** be parallel to the transport direction of the printed-circuit board.

The footprint must incorporate solder thieves at the downstream end.

- For packages with leads on four sides, the footprint must be placed at a 45° angle to the transport direction of the printed-circuit board. The footprint must incorporate solder thieves downstream and at the side corners.

During placement and before soldering, the package must be fixed with a droplet of adhesive. The adhesive can be applied by screen printing, pin transfer or syringe dispensing. The package can be soldered after the adhesive is cured.

Typical dwell time of the leads in the wave ranges from 3 seconds to 4 seconds at 250 °C or 265 °C, depending on solder material applied, SnPb or Pb-free respectively.

A mildly-activated flux will eliminate the need for removal of corrosive residues in most applications.

12.4 Manual soldering

Fix the component by first soldering two diagonally-opposite end leads. Use a low voltage (24 V or less) soldering iron applied to the flat part of the lead. Contact time must be limited to 10 seconds at up to 300 °C.

When using a dedicated tool, all other leads can be soldered in one operation within 2 seconds to 5 seconds between 270 °C and 320 °C.

12.5 Package related soldering information

Table 29: Suitability of surface mount IC packages for wave and reflow soldering methods

Package [1]	Soldering method	
	Wave	Reflow [2]
BGA, HTSSON..T [3], LBGA, LFBGA, SQFP, SSOP..T [3], TFBGA, VFBGA, XSON	not suitable	suitable
DHVQFN, HBCC, HBGA, HLQFP, HSO, HSOP, HSQFP, HSSON, HTQFP, HTSSOP, HVQFN, HVSON, SMS	not suitable [4]	suitable
PLCC [5], SO, SOJ	suitable	suitable
LQFP, QFP, TQFP	not recommended [5] [6]	suitable
SSOP, TSSOP, VSO, VSSOP	not recommended [7]	suitable
CWQCCN..L [8], PMFP [9], WQCCN..L [8]	not suitable	not suitable

[1] For more detailed information on the BGA packages refer to the *(LF)BGA Application Note (AN01026)*; order a copy from your Philips Semiconductors sales office.

[2] All surface mount (SMD) packages are moisture sensitive. Depending upon the moisture content, the maximum temperature (with respect to time) and body size of the package, there is a risk that internal or external package cracks may occur due to vaporization of the moisture in them (the so called popcorn effect). For details, refer to the Drypack information in the *Data Handbook IC26; Integrated Circuit Packages; Section: Packing Methods*.

[3] These transparent plastic packages are extremely sensitive to reflow soldering conditions and must on no account be processed through more than one soldering cycle or subjected to infrared reflow soldering with peak temperature exceeding 217 °C ± 10 °C measured in the atmosphere of the reflow oven. The package body peak temperature must be kept as low as possible.

- [4] These packages are not suitable for wave soldering. On versions with the heatsink on the bottom side, the solder cannot penetrate between the printed-circuit board and the heatsink. On versions with the heatsink on the top side, the solder might be deposited on the heatsink surface.
- [5] If wave soldering is considered, then the package must be placed at a 45° angle to the solder wave direction. The package footprint must incorporate solder thieves downstream and at the side corners.
- [6] Wave soldering is suitable for LQFP, QFP and TQFP packages with a pitch (e) larger than 0.8 mm; it is definitely not suitable for packages with a pitch (e) equal to or smaller than 0.65 mm.
- [7] Wave soldering is suitable for SSOP, TSSOP, VSO and VSSOP packages with a pitch (e) equal to or larger than 0.65 mm; it is definitely not suitable for packages with a pitch (e) equal to or smaller than 0.5 mm.
- [8] Image sensor packages in principle should not be soldered. They are mounted in sockets or delivered pre-mounted on flex foil. However, the image sensor package can be mounted by the client on a flex foil by using a hot bar soldering process. The appropriate soldering profile can be provided on request.
- [9] Hot bar soldering or manual soldering is suitable for PMFP packages.

13. Abbreviations

Table 30: Abbreviations

Acronym	Description
BRG	Baud Rate Generator
CPU	Central Processing Unit
DMA	Direct Memory Access
FIFO	First-In, First-Out
ISDN	Integrated Service Digital Network
LSB	Least Significant Bit
MSB	Most Significant Bit
QUART	4-channel (Quad) Universal Asynchronous Receiver and Transmitter
UART	Universal Asynchronous Receiver and Transmitter

14. Revision history

Table 31: Revision history

Document ID	Release date	Data sheet status	Change notice	Doc. number	Supersedes
SC16C654B_654DB_2	20050620	Product data sheet	-	9397 750 14965	SC16C654B_654DB_1
Modifications:					
<ul style="list-style-type: none"> • Section 1 “General description”: <ul style="list-style-type: none"> – 2nd paragraph: added 6th sentence. – 3rd paragraph: added HVQFN48 and LFBGA64 package options, and added second sentence. • Table 1 “Ordering information”: added HVQFN48, LFBGA64, and LQFP64 (SOT414-1) package options. • Figure 5 “Pin configuration for LQFP64”: added SC16C654BIBM option • Added Figure 6 “Pin configuration for HVQFN48 (16 mode)”, Figure 7 “Pin configuration for HVQFN48 (68 mode)”, Figure 8 “Pin configuration for LFBGA64” and Figure 9 “Ball mapping for LFBGA64”. • Table 2 “Pin description”: added columns for HVQFN48 and LFBGA64 package types • moved Section 6.1.1 “The 16 mode interface” (was Section 6.2) and Section 6.1.2 “The 68 mode interface” (was Section 6.3) to be sub-sections of Section 6.1 “Interface options” • Section 6.4 “Hardware flow control”: added ‘Remark’ following second paragraph. • Section 6.10 “DMA operation”: added ‘Remark’ following first paragraph. • Table 8 “SC16C654B/654DB internal registers”: added (new) Table note 4 and its reference at FCR[3]. • Table 27 “Static characteristics”: <ul style="list-style-type: none"> – descriptive line following title: changed ‘$V_{CC} = 2.5\text{ V}, 3.3\text{ V}$ or $5.0\text{ V} \pm 10\%$,’ to ‘tolerance of $V_{CC} \pm 10\%$,’ – added ‘$V_{CC} =$ ‘ to the limits’ column headings • Table 28 “Dynamic characteristics”: <ul style="list-style-type: none"> – descriptive line following title: changed ‘$V_{CC} = 2.5\text{ V}, 3.3\text{ V}$ or $5.0\text{ V} \pm 10\%$,’ to ‘tolerance of $V_{CC} \pm 10\%$,’ – added ‘$V_{CC} =$ ‘ to the limits’ column headings – baud rate divisor Max. columns: changed ‘$2^{16} - 1 T_{RCLK}$’ to ‘$(2^{16} - 1)$’; deleted ‘ns’ from Unit column (N is a number). • Section 11 “Package outline”: added Figure 29 “Package outline SOT414-1 (LQFP64)”, Figure 30 “Package outline SOT778-3 (HVQFN48)”, and Figure 31 “Package outline SOT686-1 (LFBGA64)”. • Added Section 13 “Abbreviations” on page 55 • Section 18 “Trademarks” re-written. 					
SC16C654B_654DB_1	20050209	Product data sheet	-	9397 750 13115	-

15. Data sheet status

Level	Data sheet status ^[1]	Product status ^{[2] [3]}	Definition
I	Objective data	Development	This data sheet contains data from the objective specification for product development. Philips Semiconductors reserves the right to change the specification in any manner without notice.
II	Preliminary data	Qualification	This data sheet contains data from the preliminary specification. Supplementary data will be published at a later date. Philips Semiconductors reserves the right to change the specification without notice, in order to improve the design and supply the best possible product.
III	Product data	Production	This data sheet contains data from the product specification. Philips Semiconductors reserves the right to make changes at any time in order to improve the design, manufacturing and supply. Relevant changes will be communicated via a Customer Product/Process Change Notification (CPCN).

[1] Please consult the most recently issued data sheet before initiating or completing a design.

[2] The product status of the device(s) described in this data sheet may have changed since this data sheet was published. The latest information is available on the Internet at URL <http://www.semiconductors.philips.com>.

[3] For data sheets describing multiple type numbers, the highest-level product status determines the data sheet status.

16. Definitions

Short-form specification — The data in a short-form specification is extracted from a full data sheet with the same type number and title. For detailed information see the relevant data sheet or data handbook.

Limiting values definition — Limiting values given are in accordance with the Absolute Maximum Rating System (IEC 60134). Stress above one or more of the limiting values may cause permanent damage to the device. These are stress ratings only and operation of the device at these or at any other conditions above those given in the Characteristics sections of the specification is not implied. Exposure to limiting values for extended periods may affect device reliability.

Application information — Applications that are described herein for any of these products are for illustrative purposes only. Philips Semiconductors make no representation or warranty that such applications will be suitable for the specified use without further testing or modification.

17. Disclaimers

Life support — These products are not designed for use in life support appliances, devices, or systems where malfunction of these products can reasonably be expected to result in personal injury. Philips Semiconductors

19. Contact information

For additional information, please visit: <http://www.semiconductors.philips.com>

For sales office addresses, send an email to: sales.addresses@www.semiconductors.philips.com

customers using or selling these products for use in such applications do so at their own risk and agree to fully indemnify Philips Semiconductors for any damages resulting from such application.

Right to make changes — Philips Semiconductors reserves the right to make changes in the products - including circuits, standard cells, and/or software - described or contained herein in order to improve design and/or performance. When the product is in full production (status 'Production'), relevant changes will be communicated via a Customer Product/Process Change Notification (CPCN). Philips Semiconductors assumes no responsibility or liability for the use of any of these products, conveys no license or title under any patent, copyright, or mask work right to these products, and makes no representations or warranties that these products are free from patent, copyright, or mask work right infringement, unless otherwise specified.

18. Trademarks

Notice — All referenced brands, product names, service names and trademarks are the property of their respective owners.

20. Contents

1	General description	1	10.1	Timing diagrams	41
2	Features	1	11	Package outline	48
3	Ordering information	2	12	Soldering	53
4	Block diagram	3	12.1	Introduction to soldering surface mount packages	53
5	Pinning information	5	12.2	Reflow soldering	53
5.1	Pinning	5	12.3	Wave soldering	53
5.2	Pin description	10	12.4	Manual soldering	54
6	Functional description	14	12.5	Package related soldering information	54
6.1	Interface options	16	13	Abbreviations	55
6.1.1	The 16 mode interface	16	14	Revision history	56
6.1.2	The 68 mode interface	16	15	Data sheet status	57
6.2	Internal registers	17	16	Definitions	57
6.3	FIFO operation	17	17	Disclaimers	57
6.4	Hardware flow control	18	18	Trademarks	57
6.5	Software flow control	18	19	Contact information	57
6.6	Special feature software flow control	19			
6.7	Xon any feature	19			
6.8	Hardware/software and time-out interrupts	19			
6.9	Programmable baud rate generator	20			
6.10	DMA operation	22			
6.11	Sleep mode	22			
6.12	Loop-back mode	22			
7	Register descriptions	24			
7.1	Transmit (THR) and Receive (RHR) Holding Registers	25			
7.2	Interrupt Enable Register (IER)	25			
7.2.1	IER versus Receive FIFO interrupt mode operation	26			
7.2.2	IER versus Receive/Transmit FIFO polled mode operation	26			
7.3	FIFO Control Register (FCR)	27			
7.3.1	DMA mode	27			
7.3.1.1	Mode 0 (FCR bit 3 = 0)	27			
7.3.1.2	Mode 1 (FCR bit 3 = 1)	27			
7.3.2	FIFO mode	27			
7.4	Interrupt Status Register (ISR)	29			
7.5	Line Control Register (LCR)	30			
7.6	Modem Control Register (MCR)	31			
7.7	Line Status Register (LSR)	33			
7.8	Modem Status Register (MSR)	34			
7.9	Scratchpad Register (SPR)	35			
7.10	Enhanced Feature Register (EFR)	35			
7.11	SC16C654B/654DB external reset conditions	36			
8	Limiting values	37			
9	Static characteristics	38			
10	Dynamic characteristics	39			



© Koninklijke Philips Electronics N.V. 2005

All rights are reserved. Reproduction in whole or in part is prohibited without the prior written consent of the copyright owner. The information presented in this document does not form part of any quotation or contract, is believed to be accurate and reliable and may be changed without notice. No liability will be accepted by the publisher for any consequence of its use. Publication thereof does not convey nor imply any license under patent- or other industrial or intellectual property rights.

Date of release: 20 June 2005
Document number: 9397 750 14965

Published in The Netherlands

Mouser Electronics

Authorized Distributor

Click to View Pricing, Inventory, Delivery & Lifecycle Information:

[NXP:](#)

[SC16C654BIA68,512](#) [SC16C654BIA68,529](#) [SC16C654BIA68,518](#) [SC16C654BIB64,157](#) [SC16C654BIB64,128](#)
[SC16C654BIB64,151](#) [SC16C654BIBM,157](#) [SC16C654BIBM,128](#) [SC16C654BIBM,151](#) [SC16C654BIBS,557](#)
[SC16C654BIBS,528](#) [SC16C654BIBS,551](#) [SC16C654BIEC,557](#) [SC16C654BIEC,528](#) [SC16C654BIEC,551](#)
[SC16C654DBIB64,157](#) [SC16C654DBIB64,128](#) [SC16C654DBIB64,151](#)



Компания «ЭлектроПласт» предлагает заключение долгосрочных отношений при поставках импортных электронных компонентов на взаимовыгодных условиях!

Наши преимущества:

- Оперативные поставки широкого спектра электронных компонентов отечественного и импортного производства напрямую от производителей и с крупнейших мировых складов;
- Поставка более 17-ти миллионов наименований электронных компонентов;
- Поставка сложных, дефицитных, либо снятых с производства позиций;
- Оперативные сроки поставки под заказ (от 5 рабочих дней);
- Экспресс доставка в любую точку России;
- Техническая поддержка проекта, помощь в подборе аналогов, поставка прототипов;
- Система менеджмента качества сертифицирована по Международному стандарту ISO 9001;
- Лицензия ФСБ на осуществление работ с использованием сведений, составляющих государственную тайну;
- Поставка специализированных компонентов (Xilinx, Altera, Analog Devices, Intersil, Interpoint, Microsemi, Aeroflex, Peregrine, Syfer, Eurofarad, Texas Instrument, Miteq, Cobham, E2V, MA-COM, Hittite, Mini-Circuits, General Dynamics и др.);

Помимо этого, одним из направлений компании «ЭлектроПласт» является направление «Источники питания». Мы предлагаем Вам помощь Конструкторского отдела:

- Подбор оптимального решения, техническое обоснование при выборе компонента;
- Подбор аналогов;
- Консультации по применению компонента;
- Поставка образцов и прототипов;
- Техническая поддержка проекта;
- Защита от снятия компонента с производства.



Как с нами связаться

Телефон: 8 (812) 309 58 32 (многоканальный)

Факс: 8 (812) 320-02-42

Электронная почта: org@eplast1.ru

Адрес: 198099, г. Санкт-Петербург, ул. Калинина, дом 2, корпус 4, литера А.