

## DESCRIPTION

Demonstration Circuit 1612A is a fully integrated LED driver with 750mA switch current featuring the LT<sup>®</sup>3519-1/LT3519-2. The board is optimized to drive an LED string of up to 16V at 150mA in a SEPIC topology. The high input voltage range, high-efficiency low-side integrated 45V 750mA power switch and catch diode, integrated compensation, low voltage floating current sense amplifier, high pwm dimming ratio, overvoltage protection, shutdown control pin, analog LED current dimming control, and fixed 1MHz/2.2MHz switching frequency make the LT3519-1/LT3519-2 an extremely versatile and powerful high frequency LED driving IC.

DC1612A has overvoltage protection at 18V in case the LEDs are open or not properly attached to the terminals on the PCB. The shutdown function is activated by pulling the SHDN/UVLO terminal to ground. The CTRL terminal can be used to analog dim the LED current. The CTRL terminal is pulled up with a resistor divider between PVIN and GND. As PVIN drops below 7.4V, CTRL voltage drops below its full-scale threshold and the LED current scales back.

The VIN pin is tied directly to the PVIN terminal through R8, a zero ohm resistor. The VIN pin and terminal can be separated from PVIN for some applications such as buck mode by removing R8. A few simple modifications can be made to DC1612A in order to convert the board from a SEPIC LED driver to a boost, buck mode, or buck-boost mode LED driver. Please consult the datasheet for schematic details and the factory for customization details.

The LT3519-1/-2 datasheet gives a complete description of the part, operation and applications information. The datasheet must be read in conjunction with this Quick Start Guide for Demonstration Circuit 1612A. The LT3519-1/-2 is assembled in a small 16-lead plastic MSOP package. Proper board layout is essential for maximum thermal performance. See the datasheet section 'Layout Considerations'.

**Design files for this circuit board are available. Call the LTC factory.**

 and LT are registered trademarks of Linear Technology Corporation.

**Table 1. Typical Performance Summary for DC1612A-A LT3519-1**

PARAMETER FOR DC1612A-A LT3519-1	CONDITION	VALUE (TYPICAL)
PVIN=VIN Input Voltage Range	Operating	6V-24V
PVIN=VIN Full-Scale LED Current Input Voltage Range	I <sub>LED</sub> =150mA R <sub>6</sub> =1M $\Omega$ R <sub>7</sub> =174k $\Omega$	8V-24V
Switching Frequency	LT3519-1	1MHz
LED String Current I <sub>LED</sub>	R <sub>1</sub> =1.69 $\Omega$	150mA
OVP Open LED Voltage	R <sub>2</sub> =1M $\Omega$ R <sub>3</sub> =69.8k $\Omega$	18V
Efficiency	PVIN=VIN=12V V <sub>LED</sub> =16V I <sub>LED</sub> =150mA	80.8%
Under Voltage Lockout	R <sub>4</sub> =1M $\Omega$ R <sub>5</sub> =261k $\Omega$	6.0V
Low Voltage Rising Turn-On (UVLO + V <sub>HYST</sub> )		8.1V

**Table 2. Typical Performance Summary for DC1612A-B LT3519-2**

PARAMETER FOR DC1612A-B LT3519-2	CONDITION	VALUE (TYPICAL)
PVIN=VIN Input Voltage Range	Operating	7V-24V
PVIN=VIN Full-Scale LED Current Input Voltage Range	$I_{LED}=150\text{mA}$ $R_6=1\text{M}\Omega$ $R_7=174\text{k}\Omega$	8V-24V
Switching Frequency	LT3519-2	2.2MHz
LED String Current $I_{LED}$	$R_1=1.69\Omega$	150mA
OVP Open LED Voltage	$R_2=1\text{M}\Omega$ $R_3=69.8\text{k}\Omega$	18V
Efficiency	$PVIN=VIN=12\text{V}$ $V_{LED}=16\text{V}$ $I_{LED}=150\text{mA}$	79.4%
Under Voltage Lockout	$R_4=1\text{M}\Omega$ $R_5=215\text{k}\Omega$	7.0V
Low Voltage Rising Turn-On ( $UVLO + V_{HYST}$ )		9.1V

## QUICK START PROCEDURE

DC1612A is easy to set up to evaluate the performance of the LT3519-1/LT3519-2. Follow the procedure below:

**NOTE:** Make sure that the input voltage does not exceed 24V at all times.

1. Connect a string of LEDs with forward voltage less than 16V (at 150mA) to the LED+ and LED- terminals on the PCB as shown.
2. With power off, connect a **6V\*-24V** input power supply to the VIN (or PVIN) and GND terminals on the PCB.

**NOTE:** \*6V is the minimum input voltage for DC1612A-A. 7V is the minimum input voltage for DC1612A-B. 24V is the maximum input voltage for both SEPIC applications with 16V LED and 18V OVP.

3. Connect a 5V source to PWM and GND.
4. Turn the input power on and observe the regulated LED current, the circuit efficiency, etc. without looking directly at the LEDs.
5. For PWM dimming, tie a 100Hz (or higher), 5V PWM waveform to the PWM terminal and GND and observe the PWM dimming LED current and PWM gate waveforms.
6. For shutdown, tie the  $\overline{\text{SHDN}}/UVLO$  terminal to GND and observe the IC turning off.

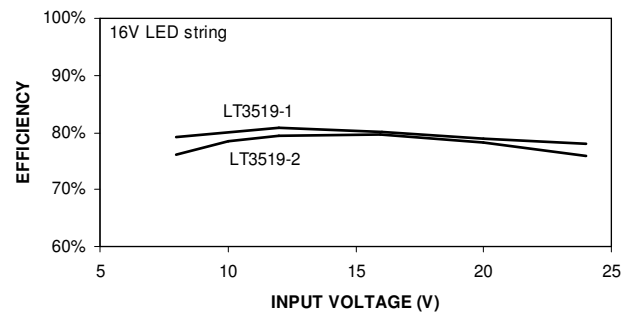

Figure 1. DC1612A Efficiency vs. PVIN 16VLED 150mA

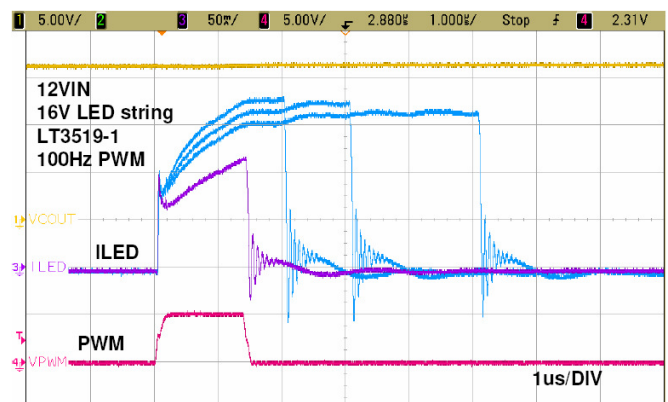

Figure 2. DC1612A-A 16VLED PWM Dimming PVIN=12V

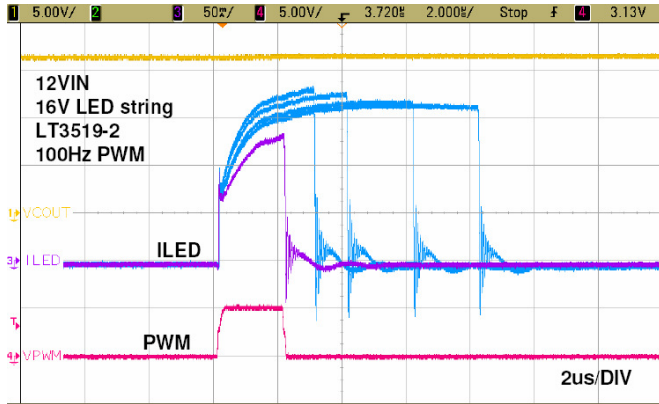

Figure 3. DC1612A-B 16VLED PWM Dimming PVIN=12V

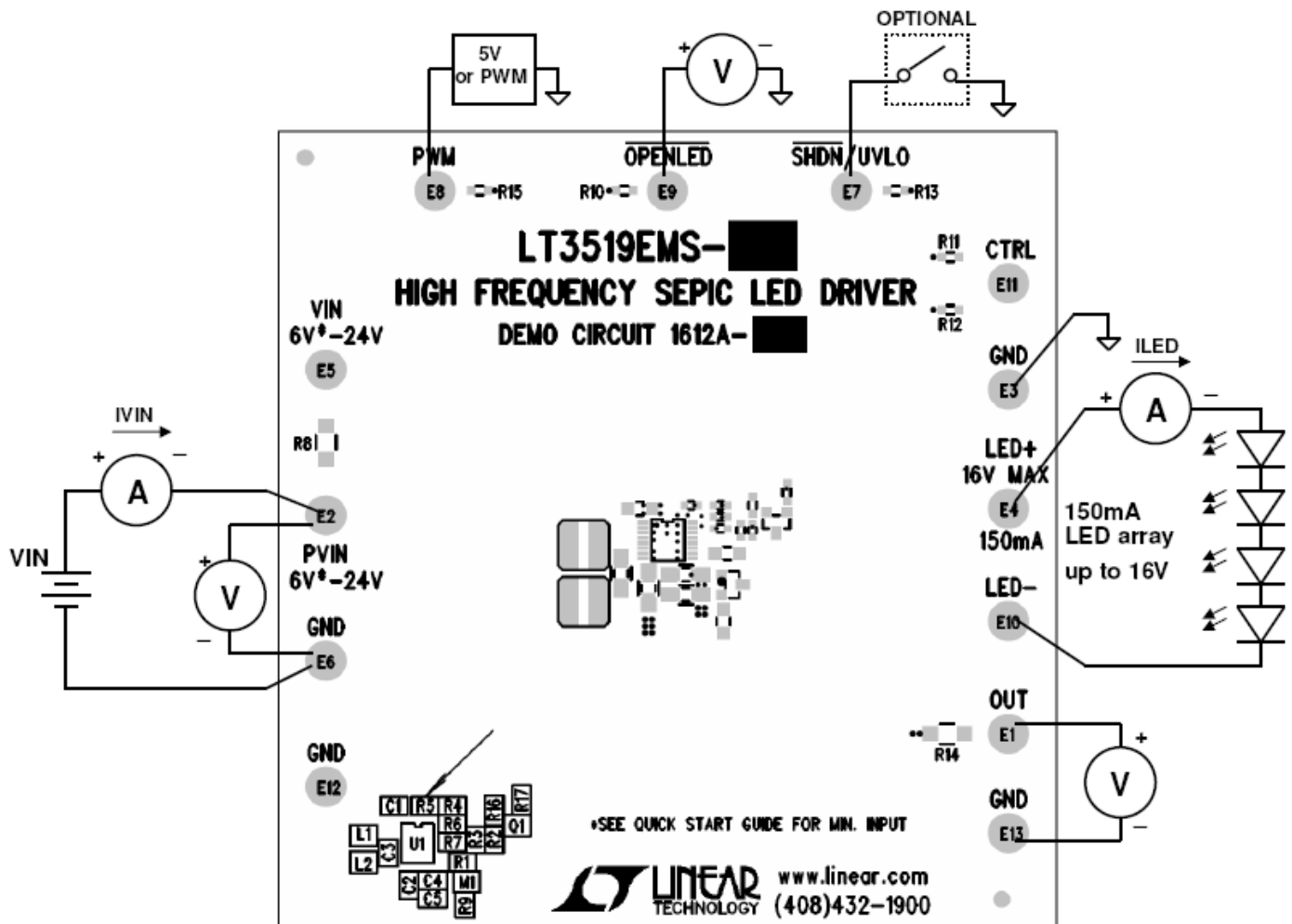

Figure 4. Proper Measurement Equipment Setup

## TERMINAL OPTIONS

**OPENLED** – The  $\overline{\text{OPENLED}}$  terminal is tied directly to the OPENLED pin. If there is a open LED condition, the terminal is pulled low. When there is no fault, the terminal is pulled up to VIN with a 100k resistor. This terminal can be monitored with a voltage meter, tied to the input of another device, or left floating.

**SHDN/UVLO** – This terminal is tied directly to the SHDN/UVLO pin. A resistor divider from PVIN to GND sets the voltage on this terminal/pin. These resistors can be easily adjusted for both the UVLO level and the amount of rising hysteresis. See the datasheet for details. The terminal can also be used to shut the IC down and turn off the LEDs. Tie the terminal directly to GND or place a voltage on the terminal below the shutdown threshold of the IC in order to place the IC in shutdown and turn off the LEDs.

**CTRL** – This terminal is tied directly to the CTRL pin. A resistor divider from PVIN to GND sets the voltage on this terminal/pin. PVIN below 8V reduces the LED current (analog dimming) below 150mA. The divider can be adjusted for different analog dimming levels. Pulling the CTRL pin to GND turns the LEDs off. An exter-

nal voltage applied to the CTRL terminal can reduce the LED current. See the datasheet for analog dimming details. It is okay to float this terminal.

**PWM** – This terminal is tied directly to the PWM pin and to the gate of the N-Channel MOSFET in series with the LED string. M1 requires a 5V gate drive for proper operation, but a lower voltage MOSFET can be used in its place. PWM dimming performance of the LT3519-1/-2 is discussed in the datasheet. Make sure to supply a proper PWM dimming voltage, frequency, and duty cycle to the LT3519-1/-2 SEPIC application. If PWM dimming is not used, the PWM terminal can be tied directly to a 5V DC source. If this terminal is left unconnected, the LEDs will not turn on.

**VIN and PVIN** – VIN is tied directly to the VIN pin of the IC. PVIN is tied directly to the inductor. The two are shorted together with a zero ohm resistor R8. R8 can be removed and VIN can be powered separately from PVIN or VIN can be tied directly to the OUT terminal for buck mode operation with resistor option R14.

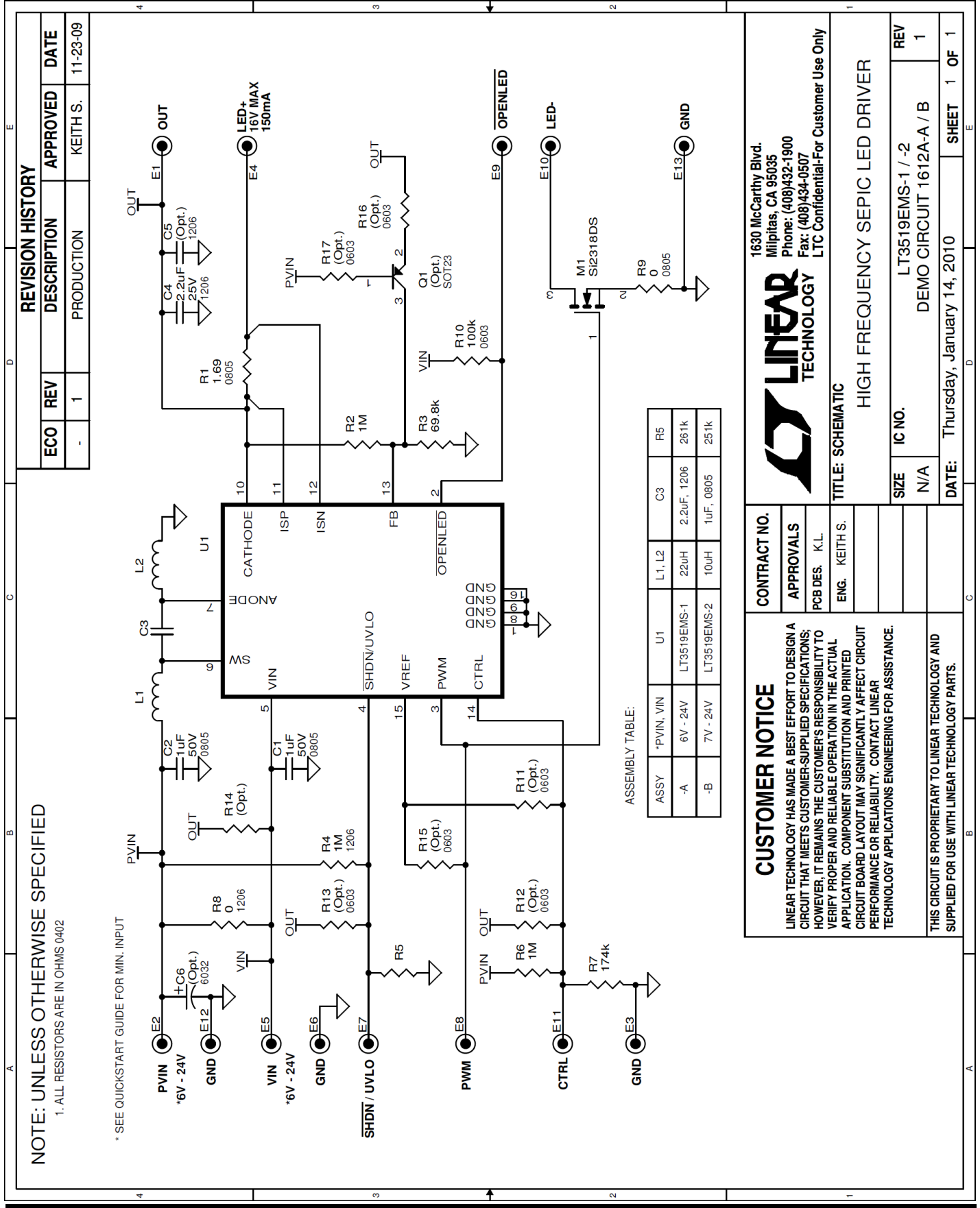



Компания «ЭлектроПласт» предлагает заключение долгосрочных отношений при поставках импортных электронных компонентов на взаимовыгодных условиях!

Наши преимущества:

- Оперативные поставки широкого спектра электронных компонентов отечественного и импортного производства напрямую от производителей и с крупнейших мировых складов;
- Поставка более 17-ти миллионов наименований электронных компонентов;
- Поставка сложных, дефицитных, либо снятых с производства позиций;
- Оперативные сроки поставки под заказ (от 5 рабочих дней);
- Экспресс доставка в любую точку России;
- Техническая поддержка проекта, помощь в подборе аналогов, поставка прототипов;
- Система менеджмента качества сертифицирована по Международному стандарту ISO 9001;
- Лицензия ФСБ на осуществление работ с использованием сведений, составляющих государственную тайну;
- Поставка специализированных компонентов (Xilinx, Altera, Analog Devices, Intersil, Interpoint, Microsemi, Aeroflex, Peregrine, Syfer, Eurofarad, Texas Instrument, Miteq, Cobham, E2V, MA-COM, Hittite, Mini-Circuits, General Dynamics и др.);

Помимо этого, одним из направлений компании «ЭлектроПласт» является направление «Источники питания». Мы предлагаем Вам помощь Конструкторского отдела:

- Подбор оптимального решения, техническое обоснование при выборе компонента;
- Подбор аналогов;
- Консультации по применению компонента;
- Поставка образцов и прототипов;
- Техническая поддержка проекта;
- Защита от снятия компонента с производства.



#### Как с нами связаться

**Телефон:** 8 (812) 309 58 32 (многоканальный)

**Факс:** 8 (812) 320-02-42

**Электронная почта:** [org@eplast1.ru](mailto:org@eplast1.ru)

**Адрес:** 198099, г. Санкт-Петербург, ул. Калинина, дом 2, корпус 4, литера А.