

REVISIONS					
REV	ECO	DESCRIPTION	DATE	BY	APPR
A1	-	RELEASE NEW DRAWING	15JUN18	SULLEN	TOMMY

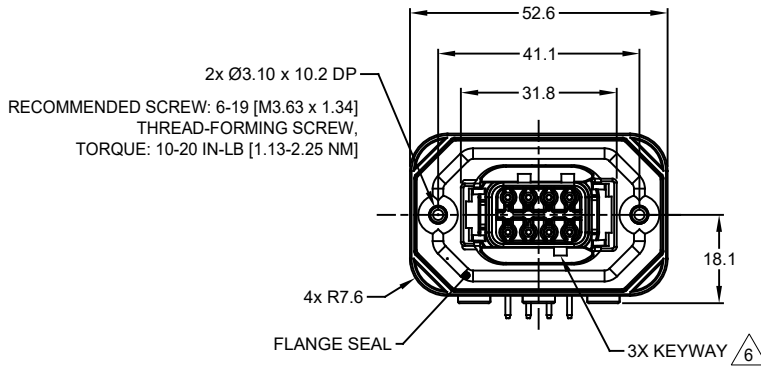

RECOMMENDED SCREW: 6-19 [M3.63 x 1.34]
 THREAD-FORMING SCREW,
 TORQUE: 10-20 IN-LB [1.13-2.25 NM]

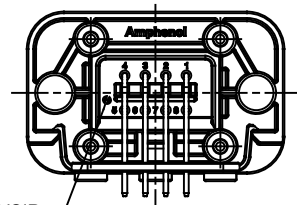
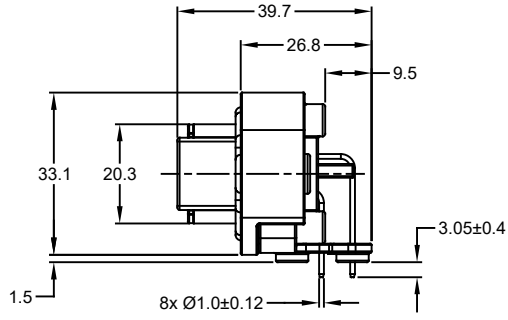

RESERVOIR

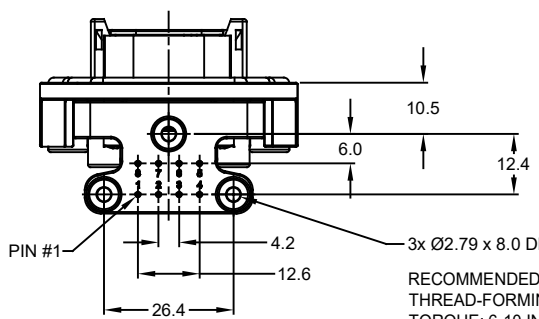
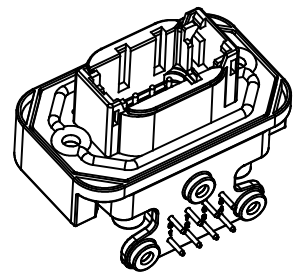

RECOMMENDED SCREW: 4-20 [M3.12 x 1.27]
 THREAD-FORMING SCREW,
 TORQUE: 6-10 IN-LB [0.68-1.13 NM]

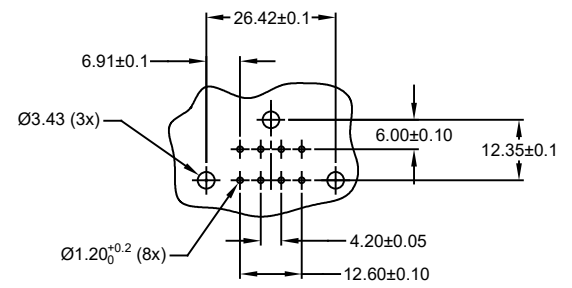

RECOMMENDED PCB LAYOUT
 VIEW FROM COMPONENTS
 SIDE OF PCB

NOTES: UNLESS OTHERWISE SPECIFIED

- MATERIAL:
 HOUSING: THERMOPLASTIC, GREY
 SEAL: SILICONE RUBBER
 CONTACT: COPPER ALLOY
- CONTACT PLATING: SEE SHEET 2
- MODIFICATIONS: FLANGE; RA PCB MOUNT
- SPECIFICATIONS:
 4.1 CURRENT RATING: 7.5 AMPS
 4.2 OPERATING TEMPERATURE: -55°C TO +125°C
 4.3 DIELECTRIC WITHSTANDING VOLTAGE: LESS THAN 2 MILLIAMPS CURRENT LEAKAGE @ 1500 VOLTS AC
 4.4 INSULATION RESISTANCE: 1000 MEGOHMS MIN @ 25°C
 4.5 MOISTURE RESISTANCE: IP67 (MATED CONDITION)
 4.6 MATING CYCLE DURABILITY: 100 CYCLES
 4.7 RoHS COMPLIANT

5. MATING PART: ATM06-08SX-
 (X = A,B,C,D KEYS ; * = MODIFICATIONS AND COLORS)

6. SEE SHEET 2 FOR OTHER KEY ARRANGEMENTS AND COLORS

7. ALL DIMENSIONS ARE FOR REFERENCE USE ONLY

ATM13-08PX-BMXX		DESCRIPTION		ITEM
QUANTITY	PART NUMBER	MATERIALS LIST		
UNLESS OTHERWISE SPECIFIED		SIGNATURES		DATE
1) All dimensions are in metric(mm).		DRAWN: SULLEN,ZHANG		15JUN18
2) Tolerances are as follows:		CHECKED: ORION,LI		15JUN18
1 PL DEC ±0.30		ENGINEER:		
2 PL DEC ±0.15		APPROVAL: TOMMY,XIE		15JUN18
3 PL DEC ±0.08		CUSTOMER:		
3) Note reference =		THIS DRAWING IS SUPPLIED FOR INFORMATION ONLY. DESIGN FEATURES, SPECIFICATIONS AND PERFORMANCE DATA SHOWN HEREON ARE THE PROPERTY OF THE AMPHENOL CORPORATION. NO RIGHTS OF REPRODUCTION ARE IMPLIED. ALL DIMENSIONS ARE SUBJECT TO NORMAL MANUFACTURING VARIATIONS.		
MATERIAL SPECIFICATIONS:		SIZE		TYPE
PROCESS SPECIFICATIONS:		B C-		
NEXT ASSY:		DWG NO:		REVISION
		ATM13-08PX-BMXX		A1
		SCALE: NONE		SHEET 1 OF 2

TITLE: PCB MOUNT RECEPTACLE RA FLANGE, ATM SERIES
 DWG NO: ATM13-08PX-BMXX
 REV: A1
 SH: 1
 OF: 2

REVISIONS					
REV	ECO	DESCRIPTION	DATE	BY	APPR
A1	-	RELEASE NEW DRAWING	15JUN18	SULLEN	TOMMY

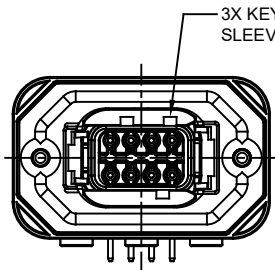

ATM13-08PA-BMXX
KEY A

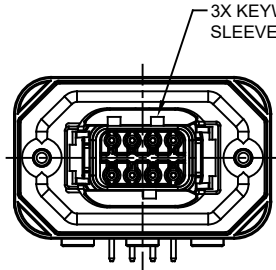

ATM13-08PB-BMXX
KEY B

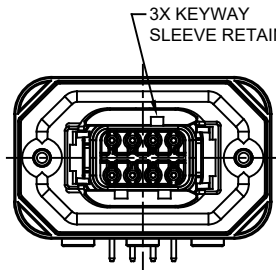

ATM13-08PC-BMXX
KEY C

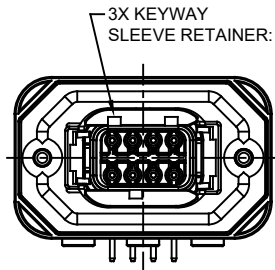

ATM13-08PD-BMXX
KEY D

ATM13-08PA-BMXX VARIANTS		
CONTACT PLATING	POTTING OR NOT IN RESERVOIR	PART NUMBER
GOLD	NO POTTING	ATM13-08PA-BM01
GOLD	POTTING	ATM13-08PA-BM02
TIN	NO POTTING	ATM13-08PA-BM03
TIN	POTTING	ATM13-08PA-BM04

ATM13-08PB-BMXX VARIANTS		
CONTACT PLATING	POTTING OR NOT IN RESERVOIR	PART NUMBER
GOLD	NO POTTING	ATM13-08PB-BM01
GOLD	POTTING	ATM13-08PB-BM02
TIN	NO POTTING	ATM13-08PB-BM03
TIN	POTTING	ATM13-08PB-BM04

ATM13-08PC-BMXX VARIANTS		
CONTACT PLATING	POTTING OR NOT IN RESERVOIR	PART NUMBER
GOLD	NO POTTING	ATM13-08PC-BM01
GOLD	POTTING	ATM13-08PC-BM02
TIN	NO POTTING	ATM13-08PC-BM03
TIN	POTTING	ATM13-08PC-BM04

ATM13-08PD-BMXX VARIANTS		
CONTACT PLATING	POTTING OR NOT IN RESERVOIR	PART NUMBER
GOLD	NO POTTING	ATM13-08PD-BM01
GOLD	POTTING	ATM13-08PD-BM02
TIN	NO POTTING	ATM13-08PD-BM03
TIN	POTTING	ATM13-08PD-BM04

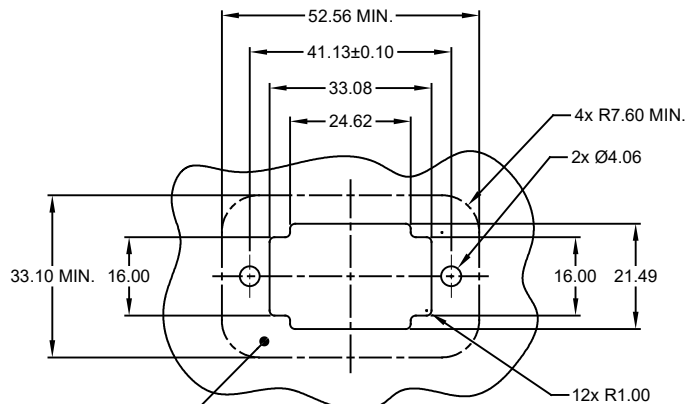

INTERNAL SEALING SURFACE FINISH TO BE 3.2/ OR BETTER $\sqrt{10.13}$

RECOMMENDED PANEL CUTOUT

ATM13-08PX-BMXX		DESCRIPTION		ITEM
QUANTITY	PART NUMBER	MATERIALS LIST		
UNLESS OTHERWISE SPECIFIED		SIGNATURES		DATE
1) All dimensions are in metric (mm).		DRAWN: SULLEN,ZHANG		15JUN18
2) Tolerances are as follows:		CHECKED: ORION,LI		15JUN18
1 PL DEC ±0.30 Fractions ±1/64		ENGINEER:		
2 PL DEC ±0.15 Angles ±1°		APPROVAL: TOMMY,XIE		15JUN18
3 PL DEC ±0.08		CUSTOMER:		
3) Note reference = Δ		THIS DRAWING IS SUPPLIED FOR INFORMATION ONLY. DESIGN FEATURES, SPECIFICATIONS AND PERFORMANCE DATA SHOWN HEREON ARE THE PROPERTY OF THE AMPHENOL CORPORATION. NO RIGHTS OF REPRODUCTION ARE IMPLIED. ALL DIMENSIONS ARE SUBJECT TO NORMAL MANUFACTURING VARIATIONS.		
MATERIAL SPECIFICATIONS:		SIZE		TYPE
PROCESS SPECIFICATIONS:		B C-		ATM13-08PX-BMXX
NEXT ASSY:		SCALE: NONE		REVISION A1
		SHEET 2 OF 2		

TITLE: PCB MOUNT RECEPTACLE 8PIN, RA FLANGE, ATM SERIES
DWG NO: ATM13-08PX-BMXX
REV: A1
SH: 2
OF: 2



Компания «ЭлектроПласт» предлагает заключение долгосрочных отношений при поставках импортных электронных компонентов на взаимовыгодных условиях!

Наши преимущества:

- Оперативные поставки широкого спектра электронных компонентов отечественного и импортного производства напрямую от производителей и с крупнейших мировых складов;
- Поставка более 17-ти миллионов наименований электронных компонентов;
- Поставка сложных, дефицитных, либо снятых с производства позиций;
- Оперативные сроки поставки под заказ (от 5 рабочих дней);
- Экспресс доставка в любую точку России;
- Техническая поддержка проекта, помощь в подборе аналогов, поставка прототипов;
- Система менеджмента качества сертифицирована по Международному стандарту ISO 9001;
- Лицензия ФСБ на осуществление работ с использованием сведений, составляющих государственную тайну;
- Поставка специализированных компонентов (Xilinx, Altera, Analog Devices, Intersil, Interpoint, Microsemi, Aeroflex, Peregrine, Syfer, Eurofarad, Texas Instrument, Miteq, Cobham, E2V, MA-COM, Hittite, Mini-Circuits, General Dynamics и др.);

Помимо этого, одним из направлений компании «ЭлектроПласт» является направление «Источники питания». Мы предлагаем Вам помощь Конструкторского отдела:

- Подбор оптимального решения, техническое обоснование при выборе компонента;
- Подбор аналогов;
- Консультации по применению компонента;
- Поставка образцов и прототипов;
- Техническая поддержка проекта;
- Защита от снятия компонента с производства.



Как с нами связаться

Телефон: 8 (812) 309 58 32 (многоканальный)

Факс: 8 (812) 320-02-42

Электронная почта: org@eplast1.ru

Адрес: 198099, г. Санкт-Петербург, ул. Калинина, дом 2, корпус 4, литера А.