

Headphone Amplifier with Electronic Volume

■ GENERAL DESCRIPTION

The **NJW1109** is a headphone amplifier with electronic volume. It includes widely gain adjustable volume, +20 to -80 dB, and mute function. These are controlled by I²C bus. The **NJW1109** is suitable for headphone output on TV set.

■ PACKAGE OUTLINE

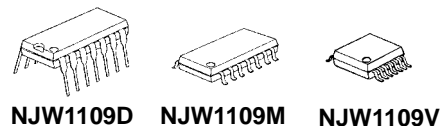

■ FEATURES

- Operating Voltage 7.5 to 10 V
- Electronic Volume +20dB to -80dB / 0.5dB step, Mute
- I²C Bus Interface
- Bi-CMOS Technology
- Package Outline DIP14, DMP14, SSOP14

■ BLOCK DIAGRAM

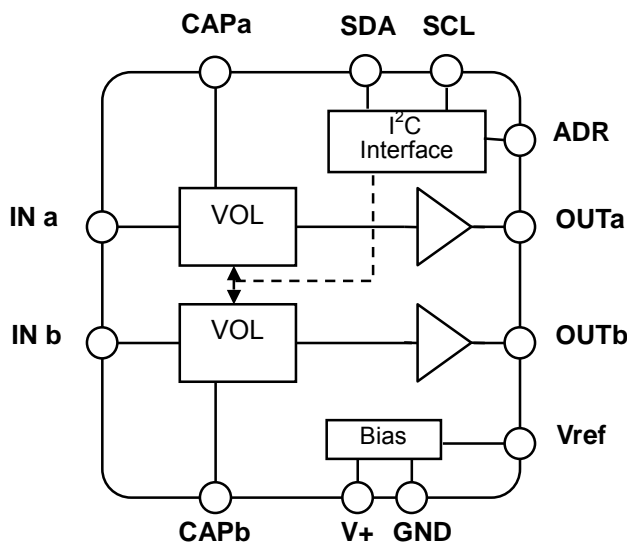

■ PIN FUNCTION

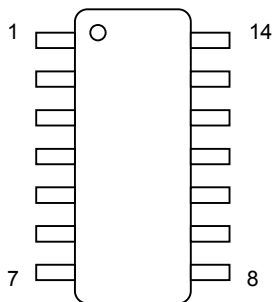

No.	SYMBOL	FUNCTION	No.	SYMBOL	FUNCTION
1	V+	Power Supply	8	SCL	I ² C Bus Clock Input
2	OUTb	Bch Output	9	Vref	Reference voltage stabilized capacitor connect terminal
3	N.C.	No Connect	10	INa	Ach Input
4	CAPb	Balance control click noise absorbing capacitor connect terminal	11	CAPa	Volume control click noise absorbing capacitor connect terminal
5	INb	Bch Input	12	N.C.	No Connect
6	ADR	I ² C Bus Slave Address Select	13	OUTa	Ach Output
7	SDA	I ² C Bus Data Input	14	GND	Ground

■ ABSOLUTE MAXIMUM RATING (Ta=25°C)

PARAMETER	SYMBOL	RATING	UNIT
Supply Voltage	V ⁺	12	V
Power Dissipation	P _D	500 (DIP14) 500* (DMP14) 440* (SSOP14)	mW
Operating Temperature Range	Topr	-20 to +75	°C
Storage Temperature Range	Tstg	-40 to +125	°C

*(Note) EIA/JEDEC STANDARD Test board(76.2 x 114.3 x 1.6mm, 2layers, FR-4)mounting

■ ELECTRICAL CHARACTERISTICS

(V⁺=9V, V_{IN}=-20dBV, f=1kHz, R_L=100Ω, VOL = 0dB, Ta=25°C)

●POWER SUPPLY

PARAMETER	SYMBOL	TEST CONDITION	MIN.	TYP.	MAX.	UNIT
Operating Voltage	V ⁺		7.5	9	10	V
Operating Current	I _{CC}	No Signal	-	5	8	mA
Reference Voltage	V _{REF}		4.0	4.5	5.0	V

●AMPLIFIER

PARAMETER	SYMBOL	TEST CONDITION	MIN.	TYP.	MAX.	UNIT
Volume Maximum Gain	G _{VMAX}	VOL = +20dB setting	18	20	22	dB
Volume Minimum Gain	G _{VMIN}	VOL = -80dB setting		-80		
Voltage Gain Channel Balance	ΔGv	VOL = 0dB setting	-1.5	0	1.5	dB
Maximum Input Voltage	V _{IM}	VOL = -10dB setting THD=3%	8.9 (2.8)	9.5 (3.0)	-	dBV (V _{rms})
Output Power	P _O	VOL = 10dB, THD=10%	70	100	-	mW
Total Harmonic Distortion	THD	VOL = 0dB setting	-	0.1	1	%
Channel Separation	CS	Rg=600Ω, Vin = 0dBV	70	80	-	dB
Mute Level	Mute	VOL = Mute, Vin = 0dBV	-	-100	-90	dB
Output Noise Voltage 1	V _{NO1}	Rg=0Ω, A-Weighted	-	-95 (18)	-85 (56)	dBV (μV _{rms})
Output Noise Voltage 2	V _{NO2}	VOL = Mute Rg=0Ω, A-Weighted	-	-105 (5.6)	-95 (18)	dBV (μV _{rms})
Power Supply Ripple Rejection	PSRR	Vripple=-20dBV, Rg=0Ω	-	70	-	dB

●CONTROL

PARAMETER	SYMBOL	TEST CONDITION	MIN.	TYP.	MAX.	UNIT
High Level Input Voltage	V _{ADRH}	High : Slave Address 84H	V ⁺ /2	-	-	V
Low Level Input Voltage	V _{ADRL}	Low : Slave Address 80H	-	-	1.0	V

■TIMING ON THE I²C BUS (SDA,SCL)

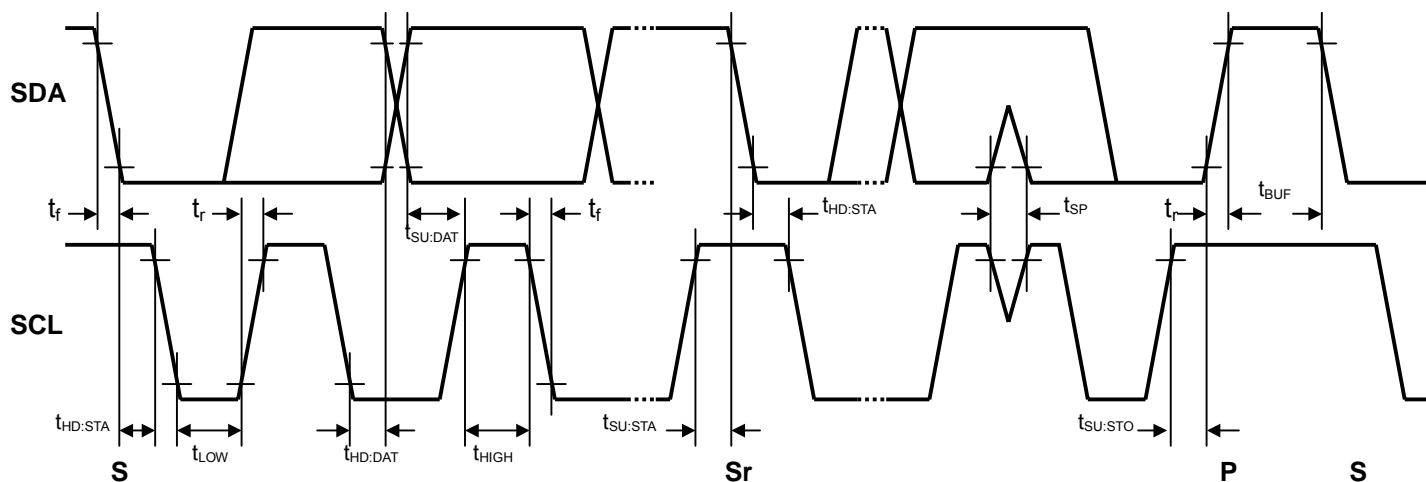

■CHARACTERISTICS OF I/O STAGES FOR I²C BUS (SDA,SCL)

I²C BUS Load Conditions

STANDARD MODE : Pull up resistance 4k Ω (Connected to +5V), Load capacitance 200pF (Connected to GND)

FAST MODE : Pull up resistance 4k Ω (Connected to +5V), Load capacitance 50pF (Connected to GND)

PARAMETER	SYMBOL	Standard mode			Fast mode			UNIT
		MIN.	TYP.	MAX.	MIN.	TYP.	MAX.	
Low Level Input Voltage	V_{IL}	0.0	-	1.5	0.0	-	1.5	V
High Level Input Voltage	V_{IH}	2.5	-	5.0	2.5	-	5.0	V
Low level output voltage (3mA at SDA pin)	V_{OL}	0	-	0.4	0	-	0.4	V
Input current each I/O pin with an input voltage between 0.1V _{DD} and 0.9V _{DDmax}	I_i	-10	-	10	-10	-	10	μ A

■CHARACTERISTICS OF BUS LINES (SDA,SCL) FOR I²C-BUS DEVICES

PARAMETER	SYMBOL	Standard mode			Fast mode			UNIT
		MIN.	TYP.	MAX.	MIN.	TYP.	MAX.	
SCL clock frequency	f _{SCL}	-	-	100	-	-	400	kHz
Hold time (repeated) START condition.	t _{HD:STA}	4.0	-	-	0.6	-	-	μs
Low period of the SCL clock	t _{LOW}	4.7	-	-	1.3	-	-	μs
High period of the SCL clock	t _{HIGH}	4.0	-	-	0.6	-	-	μs
Set-up time for a repeated START condition	t _{SU:STA}	4.7	-	-	0.6	-	-	μs
Data hold time ^(NOTE)	t _{HD:DAT}	0	-	-	0	-	-	μs
Data set-up time	t _{SU:DAT}	250	-	-	100	-	-	ns
Rise time of both SDA and SCL signals	t _r	-	-	1000	-	-	300	ns
Fall time of both SDA and SCL signals	t _f	-	-	300	-	-	300	ns
Set-up time for STOP condition	t _{SU:STO}	4.0	-	-	0.6	-	-	μs
Bus free time between a STOP and START condition	t _{BUF}	4.7	-	-	1.3	-	-	μs
Capacitive load for each bus line	C _b	-	-	400	-	-	400	pF
Noise margin at the Low level	V _{nL}	0.5	-	-	0.5	-	-	V
Noise margin at the High level	V _{nH}	1	-	-	1	-	-	V

C_b ; total capacitance of one bus line in pF.

NOTE). Data hold time : t_{HD:DAT}

Please hold the Data Hold Time (t_{HD:DAT}) to 300ns or more to avoid status of unstable at SCL falling edge.

The SDA block in the NJW1109 does not hold data. Add external data-delay-circuit of the SDA terminal, in case of not providing a hold time of at least 300nsec for the SDA in the master device.

The time-consists of the data-delay-circuit of the SDA terminal are as follows.

- (a) Low level → High level : $T_{LH} \approx R_p * C_D$
- (b) High level → Low level : $T_{HL} \approx R_D * C_D$

In addition, Schottky barrier diode (SBD) influences a Low level at the Acknowledge. Therefore choose the low forward voltage (V_f) as much as possible.

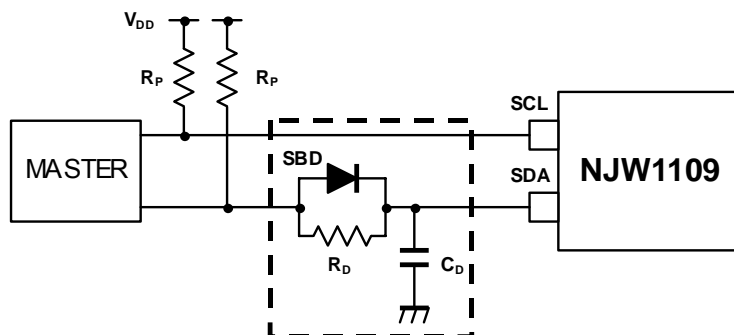

■ TERMINAL DESCRIPTION

No.	SYMBOL	FUNCTION	EQUIVALENT CIRCUIT	VOLTAGE
5	INb	Bch Input		V+/2
10	INa	Ach Input		V+/2
2	OUTb	Bch Output		V+/2
13	OUTa	Ach Output		3.8V
4	CAPb	Balance control click noise absorbing capacitor connect terminal		3.8V
11	CAPa	Volume control click noise absorbing capacitor connect terminal		3.1V

■TERMINAL DESCRIPTION

No.	SYMBOL	FUNCTION	EQUIVALENT CIRCUIT	VOLTAGE
6	ADR	I ² C Bus Slave Address Select		-
7 8	SDA SCL	I ² C Bus Data Input I ² C Bus Clock Input		-
9	Vref	Reference voltage stabilized capacitor connect terminal		V+/2
1	V+	Power Supply	-	-
14	GND	Ground	-	-

■ TEST CIRCUIT

TEST CIRCUIT 1 (G_{VMAX} , G_{VMIN} , ΔG_V , V_{IM} , P_O , THD, Mute)

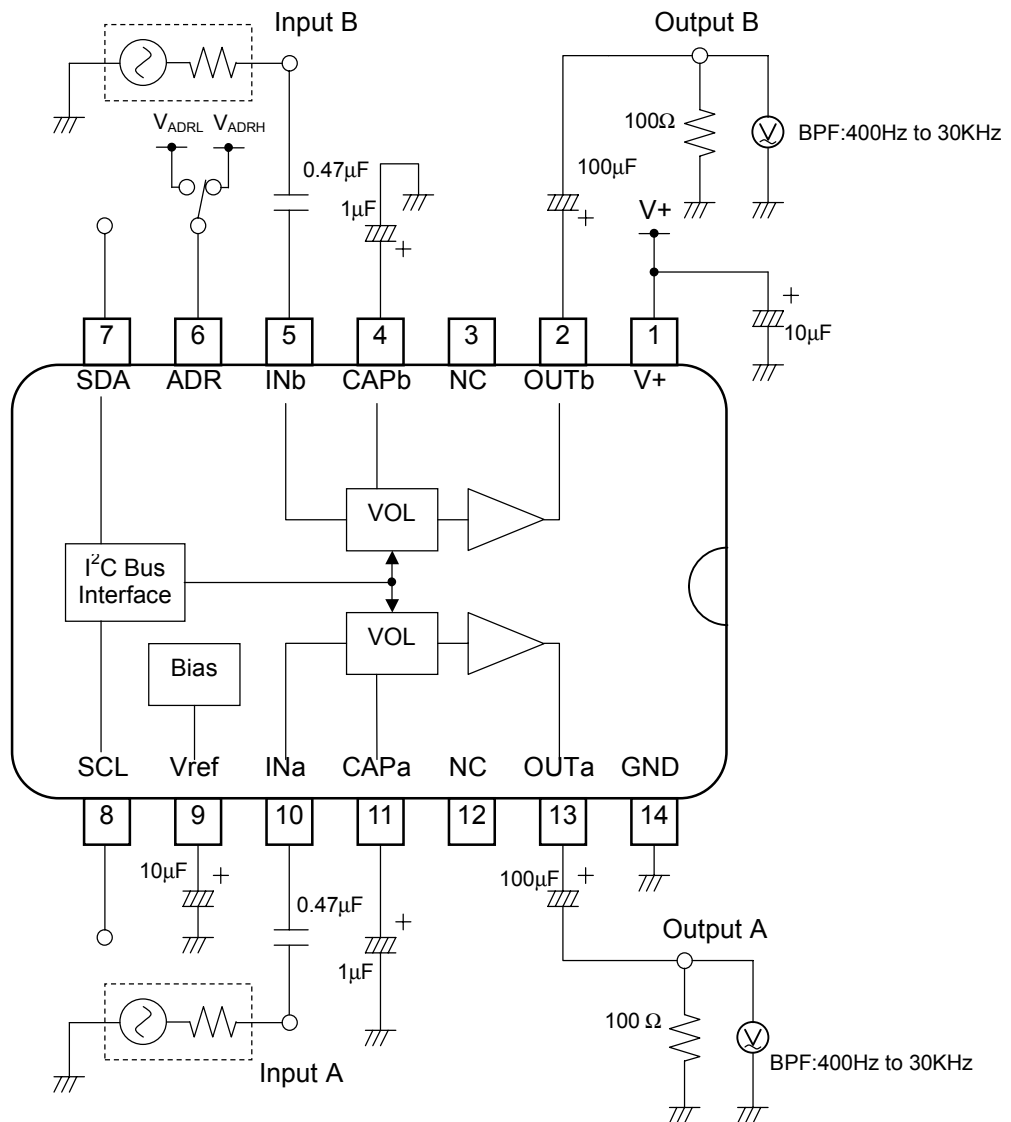

TEST CIRCUIT 2 (I_{CC}, V_{REF}, V_{NO1}, V_{NO2})

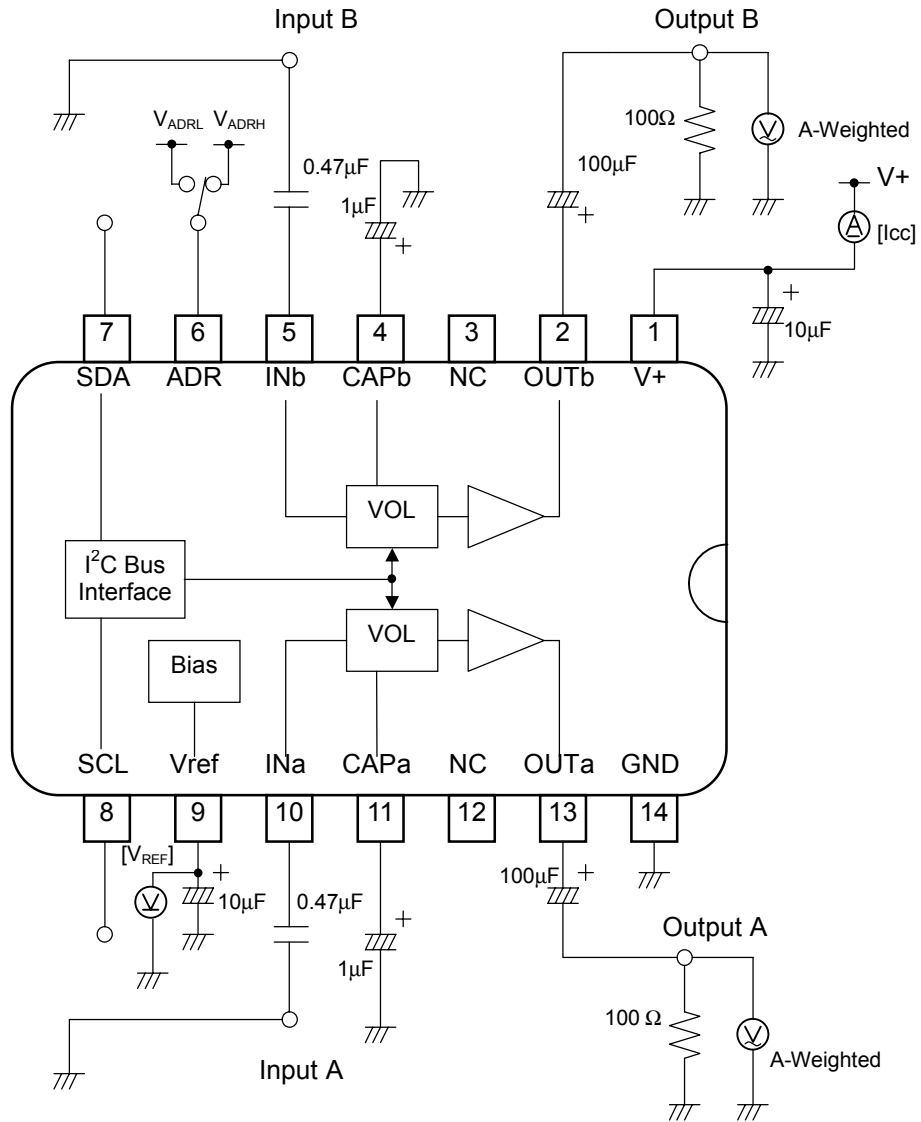

TEST CIRCUIT 3 (CS)

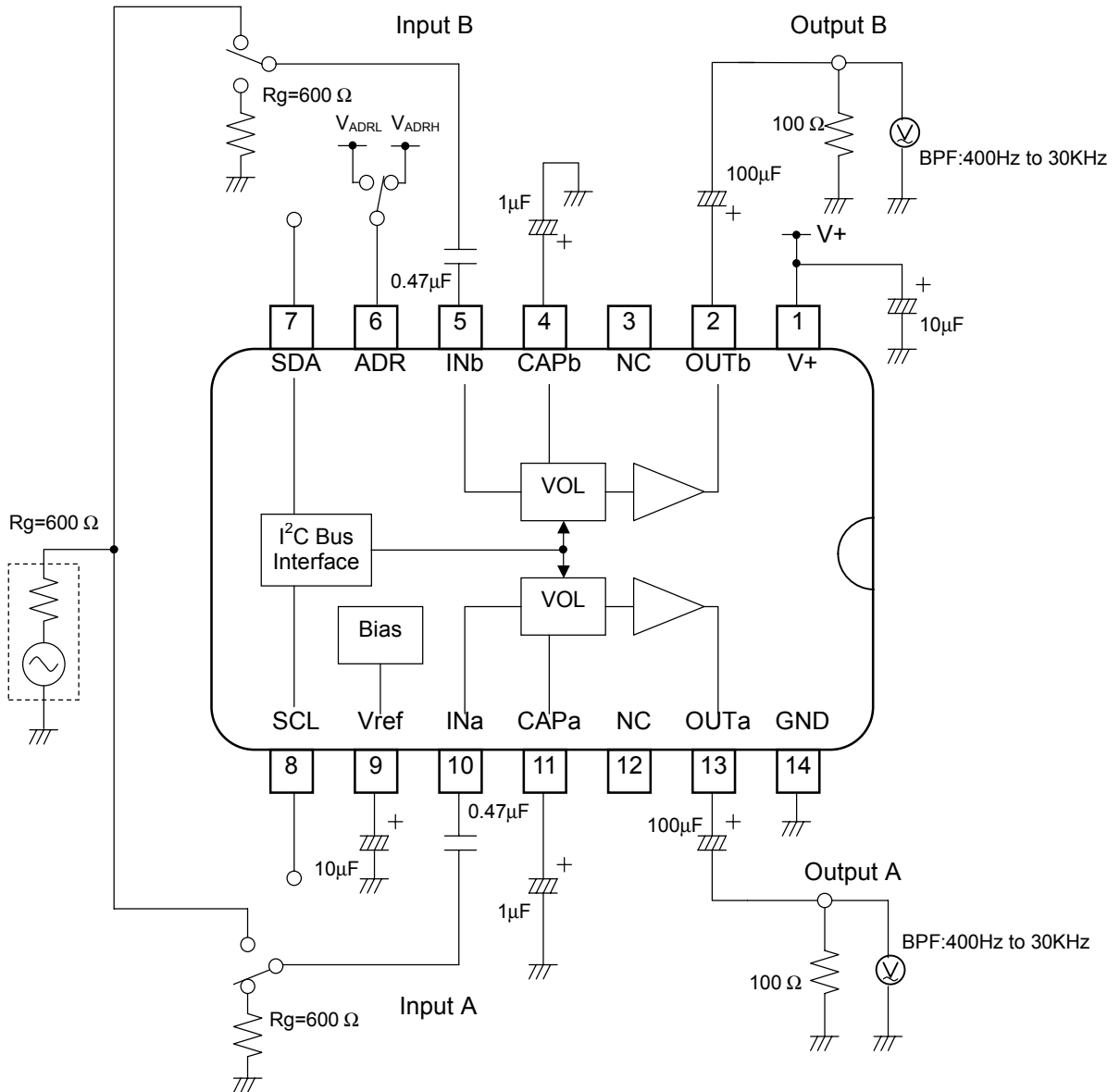

APPLICATION CIRCUIT

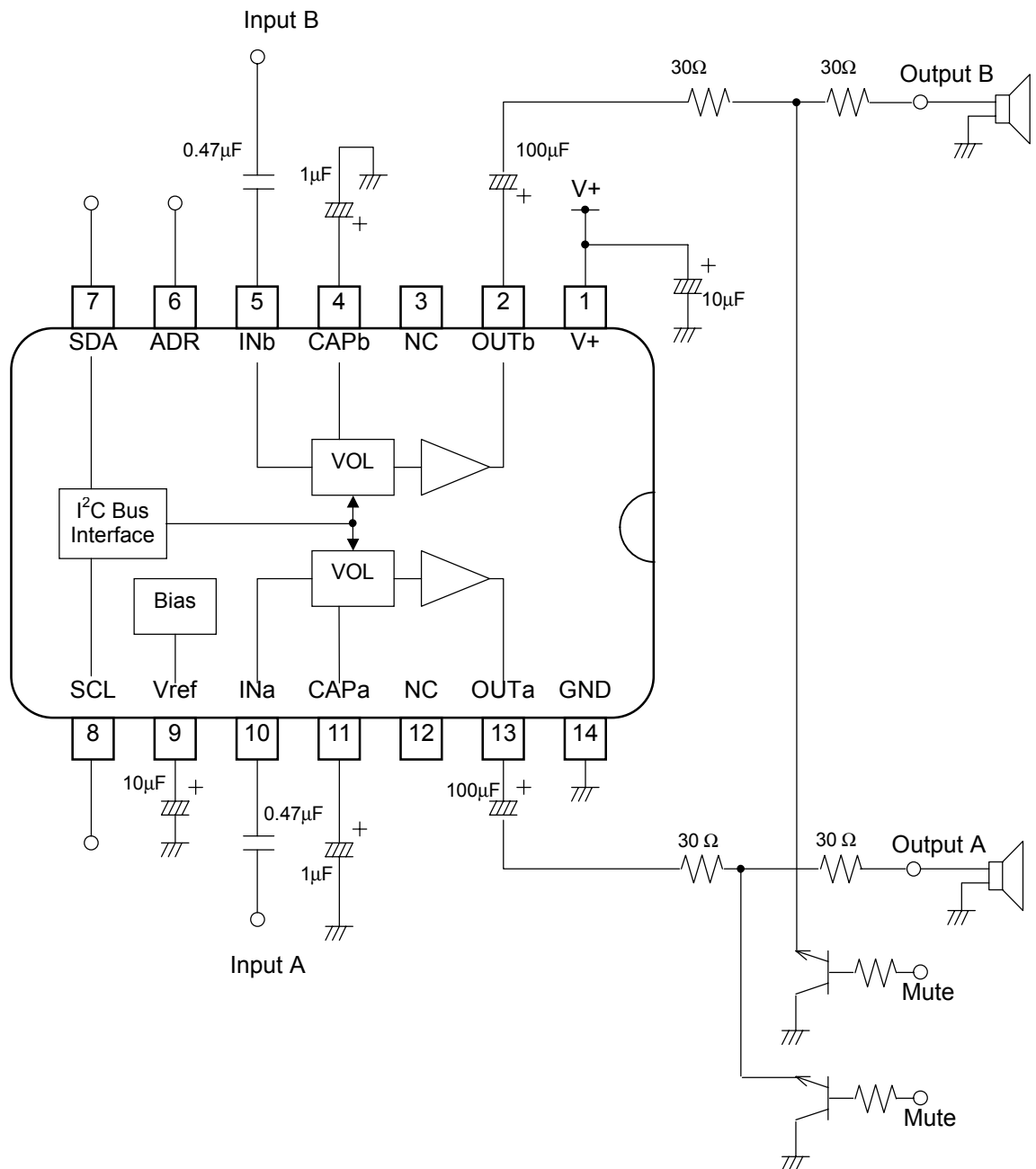

■ DEFINITION OF I²C REGISTER

● I²C BUS FORMAT

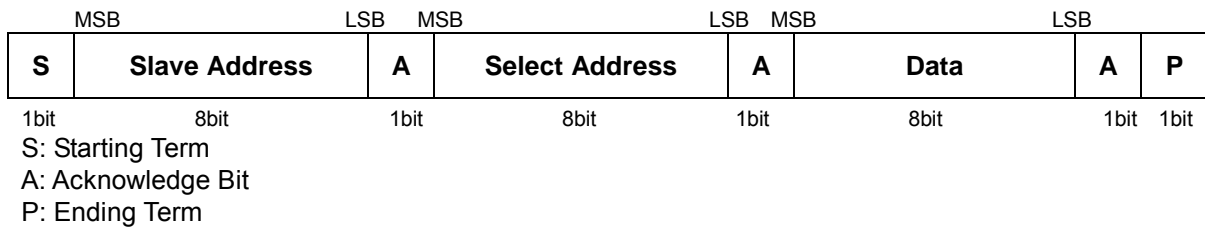

● SLAVE ADDRESS

	MSB							LSB
1	0	0	0	0	0	0	0	0
1	0	0	0	0	1	0	0	0

80H (ADR = Low)
84H (ADR = High)

● SELECT ADDRESS

The auto-increment function cycles the select address as follows.
00H→01H→00H

Select Address	BIT							
	D7	D6	D5	D4	D3	D2	D1	D0
00H	VOL							
01H	CHS	BAL					Don't Care	

■ CONTROL REGISTER DEFAULT VALUE

Control register default value is all "0".

Select Address	BIT							
	D7	D6	D5	D4	D3	D2	D1	D0
00H	0	0	0	0	0	0	0	0
01H	0	0	0	0	0	0	0	0

■ CONTROL COMMAND TABLE

a) Master Volume

Select Address	BIT							
	D7	D6	D5	D4	D3	D2	D1	D0
00H	VOL							

●VOL : Master Volume

Attenuation level : +20 to -80dB(0.5dB/step), MUTE

b) Balance

Select Address	BIT							
	D7	D6	D5	D4	D3	D2	D1	D0
01H	CHS	BAL					Don't Care	

●CHS : Balance channel select

"0" : Ach "Bch is attenuated" "1" : Bch "Ach is attenuated"

●BAL : Ach and Bch Ach and Bch Balance

Balance Level : 0 to -30dB (1dB/Step) , MUTE

■CONTROL COMMAND TABLE

a) Master Volume (Select Address: 00H) Volume level : +20 to -80dB(0.5dB/step), MUTE

		VOL							
Gain(dB)	HEX	D7	D6	D5	D4	D3	D2	D1	D0
20	FF	1	1	1	1	1	1	1	1
19.5	FE	1	1	1	1	1	1	1	0
19	FD	1	1	1	1	1	1	0	1
18.5	FC	1	1	1	1	1	1	0	0
18	FB	1	1	1	1	1	0	1	1
17.5	FA	1	1	1	1	1	0	1	0
17	F9	1	1	1	1	1	0	0	1
16.5	F8	1	1	1	1	1	0	0	0
16	F7	1	1	1	1	0	1	1	1
15.5	F6	1	1	1	1	0	1	1	0
15	F5	1	1	1	1	0	1	0	1
14.5	F4	1	1	1	1	0	1	0	0
14	F3	1	1	1	1	0	0	1	1
13.5	F2	1	1	1	1	0	0	1	0
13	F1	1	1	1	1	0	0	0	1
12.5	F0	1	1	1	1	0	0	0	0
12	EF	1	1	1	0	1	1	1	1
11.5	EE	1	1	1	0	1	1	1	0
11	ED	1	1	1	0	1	1	0	1
10.5	EC	1	1	1	0	1	1	0	0
10	EB	1	1	1	0	1	0	1	1
9.5	EA	1	1	1	0	1	0	1	0
9	E9	1	1	1	0	1	0	0	1
8.5	E8	1	1	1	0	1	0	0	0
8	E7	1	1	1	0	0	1	1	1
7.5	E6	1	1	1	0	0	1	1	0
7	E5	1	1	1	0	0	1	0	1
6.5	E4	1	1	1	0	0	1	0	0
6	E3	1	1	1	0	0	0	1	1
5.5	E2	1	1	1	0	0	0	1	0
5	E1	1	1	1	0	0	0	0	1
4.5	E0	1	1	1	0	0	0	0	0
4	DF	1	1	0	1	1	1	1	1
3.5	DE	1	1	0	1	1	1	1	0
3	DD	1	1	0	1	1	1	0	1
...
-79.5	38	0	0	1	1	1	0	0	0
-80	37	0	0	1	1	0	1	1	1
...
Mute	00	0	0	0	0	0	0	0	0

b) Balance (Select Address: 01H) Balance level : 0 to -30dB(1dB/step), MUTE

Channel Setting (CHS)	D7
Attenuated Bch Gain	0
Attenuated Ach Gain	1

Gain(dB)	BAL				
	D6	D5	D4	D3	D2
0	0	0	0	0	0
-1	0	0	0	0	1
-2	0	0	0	1	0
-3	0	0	0	1	1
-4	0	0	1	0	0
-5	0	0	1	0	1
-6	0	0	1	1	0
-7	0	0	1	1	1
-8	0	1	0	0	0
-9	0	1	0	0	1
-10	0	1	0	1	0
-11	0	1	0	1	1
-12	0	1	1	0	0
-13	0	1	1	0	1
-14	0	1	1	1	0
-15	0	1	1	1	1
-16	1	0	0	0	0
-17	1	0	0	0	1
-18	1	0	0	1	0
-19	1	0	0	1	1
-20	1	0	1	0	0
-21	1	0	1	0	1
-22	1	0	1	1	0
-23	1	0	1	1	1
-24	1	1	0	0	0
-25	1	1	0	0	1
-26	1	1	0	1	0
-27	1	1	0	1	1
-28	1	1	1	0	0
-29	1	1	1	0	1
-30	1	1	1	1	0
MUTE	1	1	1	1	1

[CAUTION]

The specifications on this data book are only given for information, without any guarantee as regards either mistakes or omissions. The application circuits in this data book are described only to show representative usages of the product and not intended for the guarantee or permission of any right including the industrial rights.

Mouser Electronics

Authorized Distributor

Click to View Pricing, Inventory, Delivery & Lifecycle Information:

[NJR:](#)

[NJW1109V-TE1](#)



Компания «ЭлектроПласт» предлагает заключение долгосрочных отношений при поставках импортных электронных компонентов на взаимовыгодных условиях!

Наши преимущества:

- Оперативные поставки широкого спектра электронных компонентов отечественного и импортного производства напрямую от производителей и с крупнейших мировых складов;
- Поставка более 17-ти миллионов наименований электронных компонентов;
- Поставка сложных, дефицитных, либо снятых с производства позиций;
- Оперативные сроки поставки под заказ (от 5 рабочих дней);
- Экспресс доставка в любую точку России;
- Техническая поддержка проекта, помощь в подборе аналогов, поставка прототипов;
- Система менеджмента качества сертифицирована по Международному стандарту ISO 9001;
- Лицензия ФСБ на осуществление работ с использованием сведений, составляющих государственную тайну;
- Поставка специализированных компонентов (Xilinx, Altera, Analog Devices, Intersil, Interpoint, Microsemi, Aeroflex, Peregrine, Syfer, Eurofarad, Texas Instrument, Miteq, Cobham, E2V, MA-COM, Hittite, Mini-Circuits, General Dynamics и др.);

Помимо этого, одним из направлений компании «ЭлектроПласт» является направление «Источники питания». Мы предлагаем Вам помощь Конструкторского отдела:

- Подбор оптимального решения, техническое обоснование при выборе компонента;
- Подбор аналогов;
- Консультации по применению компонента;
- Поставка образцов и прототипов;
- Техническая поддержка проекта;
- Защита от снятия компонента с производства.



Как с нами связаться

Телефон: 8 (812) 309 58 32 (многоканальный)

Факс: 8 (812) 320-02-42

Электронная почта: org@eplast1.ru

Адрес: 198099, г. Санкт-Петербург, ул. Калинина, дом 2, корпус 4, литера А.