

**Applications**

- Automotive
- Instrumentation
- White goods
- Telecommunications

**Benefits**

- RoHS Compliant
- Halogen and Lead Free
- Sharp detection feeling
- Compact Size

**JJ Series – Detector Switches**



TE Connectivity is pleased to introduce its JJ Series of Detector Switches, suitable for a wide variety of applications given their several presentations ranging from horizontal or vertical actuated options as well as Gull-winged, J-leaded and Through-Hole mounting possibilities.

The Detector Switches will be offered in a wide range of sizes giving the possibility for countless applications going from automotive to telecommunications.

**JJ Series – Family Classification**

| Series | Body Size                    |
|--------|------------------------------|
| JJA    | 3.5x2.8 mm                   |
| JJB    | 3.5x2.98 mm                  |
| JJC    | 3.5x3.3 mm                   |
| JJD    | 4.2x3.6 mm                   |
| JJE    | 4.7x3.5 mm                   |
| JJF    | 4.7x3.8 mm                   |
| JJG    | 5.7x4.0 mm (High-Rating)     |
| JJH    | 5.7x4.0 mm (Standard-Rating) |
| JJI    | 5.0x4.4 mm                   |
| JJJ    | 6.0x4.85 mm / 5.5x4.7 mm     |
| JJK    | 6.3x3.0 mm                   |
| JJL    | 6.5x3.9 mm                   |
| JJM    | 5.7x4.0 mm                   |
| JJN    | 5.7x4.0 mm (Wedge)           |
| JJO    | 10.0x3.8 mm                  |
| JJP    | 10.6x10.0 mm                 |

**JJE Family – 4.7x3.5 mm**

| JJE --- NOH   |                       |                 |
|---|-----------------------|-----------------|
|  | Contact Rating        | 10mA, 5VDC Max. |
|   | Contact Resistance    | 1Ω Max.         |
|   | Insulation Resistance | 100MΩ Min.      |
|   | Dielectric Strength   | 100VAC/1 minute |
|   | Operating Force       | 36gF Max.       |
|   | Travel                | 2.5mm           |
|   | Operating Life        | 100,000 cycles  |
|   | Operating Temperature | -40°C to 85°C   |
|   | Storage Temperature   | -40°C to 85°C   |

| Features  | Applications  |
|---|---|
| <ul style="list-style-type: none"> <li>Guiding post for easy orientation</li> <li>Long travel type</li> </ul> | <ul style="list-style-type: none"> <li>Consumer electronics</li> <li>Medical devices</li> </ul> |

**Circuit**

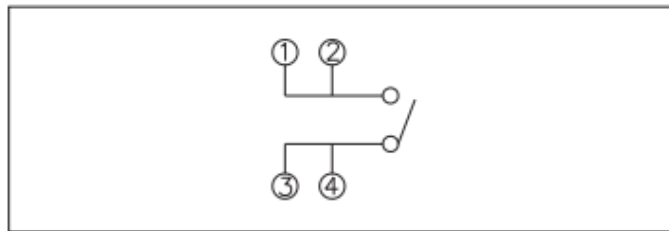

**Diagram**

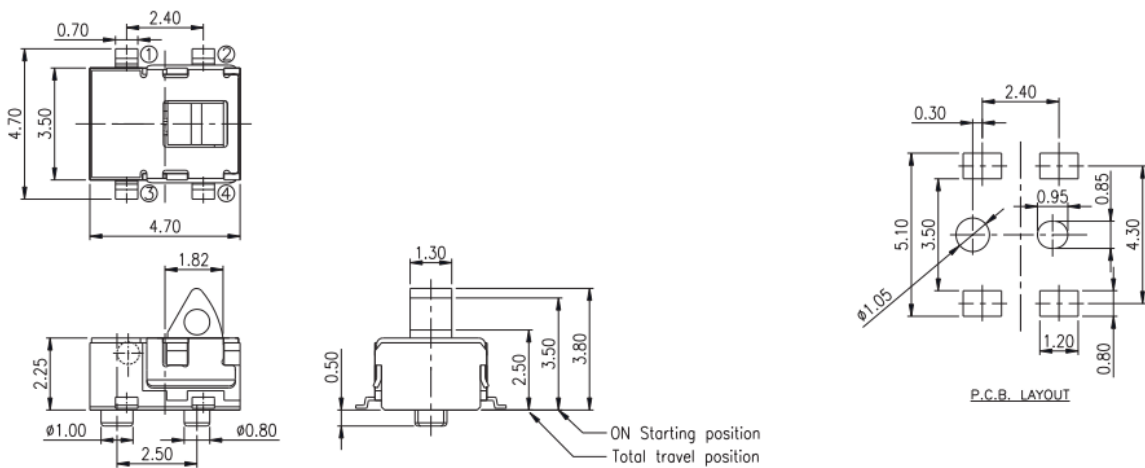

**1. Style**

“Detector Switches” are mainly used as signal switches of electric devices, with the general requirements of mechanical and electrical characteristic.

1.1 Operating Temperature Range: -40°C to 85°C

1.2 Storage Temperature Range: -40°C to 85°C

1.3 The shelf life of product is within 6 months.

**2. Current Range:** 10mA, 5VDC Max.

**3. Type of Actuation:** Momentary

**4. Test Sequence:**

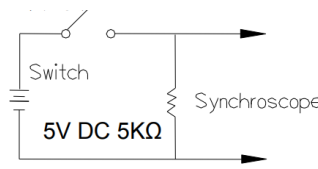
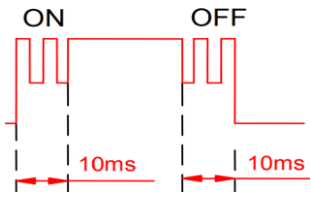
|                      | Item | Description                     | Test Conditions   | Requirements   |
|----------------------|------|---------------------------------|---|--|
| Appearance           | 1    | Visual Examination              | Physical inspection without applying any external forces.   | There shall be no defects that affect the serviceability of the product.                                   |
| Electric Performance | 2    | Contact Resistance              | Actuate the switch (2.80) and measure contact resistance using a micro-Ohmmeter.  | 1Ω Max.  |
|                      | 3    | Insulation Resistance           | Measurements shall be made at 100 VDC potential between terminals and cover.  | 100MΩ Min  |
|                      | 4    | Dielectric Withstanding Voltage | 100 VAC (50Hz or 60Hz) shall be applied across terminals and cover for 1 minute   | There shall be no breakdown or flashover   |
|                      | 5    | Bounce                          | 3 to 4 operations at a rate of 1 cycles per second Bounce<br> | 10 m seconds Max.<br> |

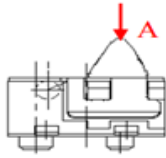
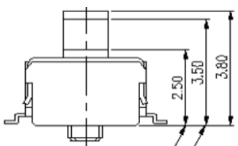
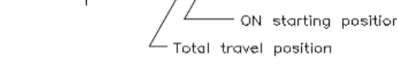
|                         |    |                        |  |  |
|-------------------------|----|------------------------|--|--|
| Mechanical Performance  | 6  | Operating Force        | As the specification shows operating force is measured<br>  | 36gf (0.35N) Max.  |
|                         | 7  | Contact (On) point     |   | 3.5±0.20mm   |
|                         | 8  | Stroke                 |    | 1.30mm   |
|                         | 9  | Stop Strength          | Operation direction:<br>1kg (9.8N) static operation force applies on the center of the actuator for 15 seconds.  | As shown in items 2 through 7.   |
|                         | 10 | Solder Heat Resistance | (See chart below)  | Shall be free from pronounced backlash and falling-off or breakage terminals (As shown in item 2 to7)  |
|                         | 11 | Solderability          | 1) Soldering Temperature : 245±3°C<br>Lead-Free solder : M705E JIS Z 3282 A (Tin 96.5%, Silver 3%, Copper 0.5%)<br>2) Flux: 5-10 sec.<br>3) Duration of solder mmerion:5±1sec  | No anti-soldering and the coverage of dipping into solder must more than 90% was requested   |
| Durability              | 12 | Operating Life         | Tested as follows:<br>1) 1mA,5 VDC resistive load<br>2) Applying a static load the operating force to the center of the stem in the direction of operation Static Load = OF Max.<br>3) Rate of Operation:15~20 operation per minute.<br>4) Cycle of Operation: 100,000 cycles Min. | 1) As shown in item 4 to 5<br>2) Operating force: ±50% of initial force.<br>3) Contact Resistance: 10Ω Max<br>4) Insulation Resistance: 10MΩ Min |
| Environmental Endurance | 13 | Vibration              | Test per Method IEC 60068-2-6:<br>1) Swing distance=1.5mm)<br>2) Frequency: 10-55Hz in 9.81-minute/10cycle.<br>3) Direction: 3 vertical directions including the directions of operation<br>4) Test time: 98.1 minute each direction   | 1) As shown in item 4 to 7<br>2)Contact Resistance: 10Ω Max<br>3)Insulation Resistance: 10MΩ Min   |

|                         |    |                     |  |  |
|-------------------------|----|---------------------|--|--|
| Environmental Endurance | 14 | Shock               | Test per Method IEC60068-2-27<br>1) Acceleration; 50G<br>2) Action time: 11±1m seconds<br>3) Testing Direction: 6 sides<br>4) Test Cycle: 3 times in each direction  | 1) As shown in item 4 to 7<br>2) Contact Resistance: 10Ω Max<br>3) Insulation Resistance: 10MΩ Min |
|                         | 15 | Cold Resistance     | Following the test set forth below the sample shall be left in normal temperature and humidity conditions for 1 hour before the measurements are made:<br>1) Temperature: -40±2°C<br>2) Time: 96hours                                    | 1) As shown in item 4 to 7<br>2) Contact Resistance: 10Ω Max<br>3) Insulation Resistance: 10MΩ Min |
|                         | 16 | Heat Resistance     | Following the test set forth below the sample shall be left in normal temperature and humidity conditions for 1 hour before the measurements are made:<br>1) Temperature: 85±2°C<br>2) Time: 96 hours                                    | 1) As shown in item 4 to 7<br>2) Contact Resistance: 10Ω Max<br>3) Insulation Resistance: 10MΩ Min |
|                         | 17 | Humidity Resistance | Following the test set forth below the sample shall be left in normal temperature and humidity conditions for 1 hour before the measurements are made:<br>1) Temperature: 40±2°C<br>2) Relative Humidity: 90 to 95%<br>3) Time: 96 hours | 1) As shown in item 4 to 7<br>2) Contact Resistance: 10Ω Max<br>3) Insulation Resistance: 10MΩ Min |

**5. Soldering Conditions:**

■ Recommended Soldering Profile for the JJE Series

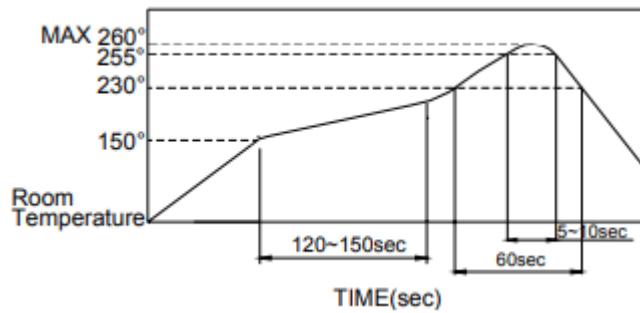

■ The condition mentioned above is the temperature on the Cu foil of the PCB surface. There are cases where board's temperature greatly differs from switch's surface be used not to allow switch's surface temperature to exceed 260°C.

■ Manual Soldering

Soldering Temperature: 350°C Max.  
Continuous Soldering Time: 5 second Max.

■ Precautions in Handling

1. Care must be taken to ensure excess flux on the top surface of the printed circuit board does not adhere to the switch.
2. Do not wash the switch.

■ Recommended storage conditions:

Store the products in the original packaging material. After opening the package, the remaining products must be stored in the appropriate moisture-proof & airtight environment.

Do not store the switch in the following environment or it may affect performance and solderability:

1. temperatures below -10° C to 40°C & humidity at 85% (min)
2. environment with corrosive gas
3. storage over 6 months
4. place in direct sunlight

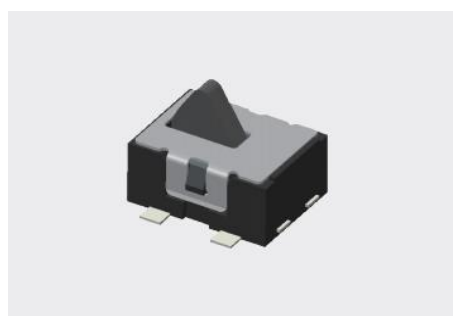
| JJE --- NO  |                       |                 |
|---|-----------------------|-----------------|
|  | Contact Rating        | 1mA, 5VDC Max.  |
|   | Contact Resistance    | 1Ω Max.         |
|   | Insulation Resistance | 50MΩ Min.       |
|   | Dielectric Strength   | 250VAC/1 minute |
|   | Operating Force       | 60gF Max.       |
|   | Travel                | 2.5mm           |
|   | Operating Life        | 100,000 cycles  |
|   | Operating Temperature | -40°C to 85°C   |
|   | Storage Temperature   | -40°C to 85°C   |

**Circuit**

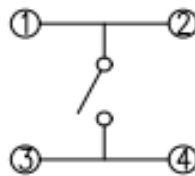

**Diagrams**

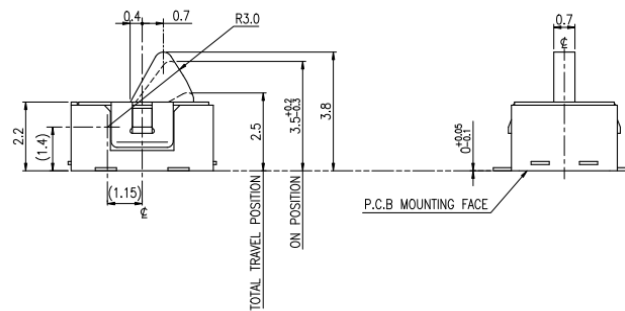
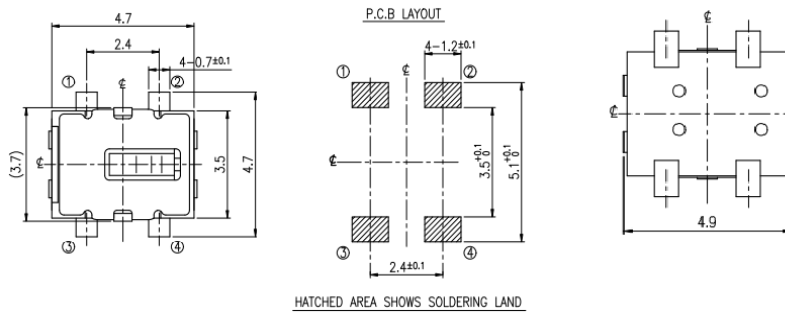



**1. Style**

“Detector Switches” are mainly used as signal switches of electric devices, with the general requirements of mechanical and electrical characteristic.

1.1 Operating Temperature Range: -40°C to 85°C

1.2 Storage Temperature Range: -40°C to 85°C

1.3 The shelf life of product is within 6 months.

**2. Current Range:** 1mA, 5VDC Max.

**3. Type of Actuation:** Momentary

**4. Test Sequence:**

|                      | Item | Description                     | Test Conditions   | Requirements   |
|----------------------|------|---------------------------------|---|--|
| Appearance           | 1    | Visual Examination              | Physical inspection without applying any external forces.   | There shall be no defects that affect the serviceability of the product. |
| Electric Performance | 2    | Contact Resistance              | Applying a static load twice the operating force to the measure position of the slider.<br>Shall be measured at 1KHz ± 200Hz (Max. 20mV, Max. 50mA.) or 1A, 5VDC. By voltage drop method. | 1Ω Max.  |
|                      | 3    | Insulation Resistance           | Measurements shall be made at 250 VDC potential between terminals and cover.  | 50MΩ Min.  |
|                      | 4    | Dielectric Withstanding Voltage | Apply 250 VAC (50Hz or 60Hz) between terminals and cover for 1 minute.  | There shall be no breakdown or flashover                                 |

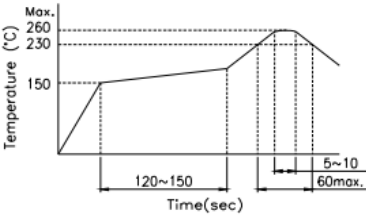

|                        |    |                           |  |   |
|------------------------|----|---------------------------|--|---|
| Mechanical Performance | 5  | Operating Force           | Applying force to the center of the stem for 1.60±0.2mm (0.063±.008in.)  | 50gF Max. (0.49N Max.)  |
|                        | 6  | Terminal Strength         | A static load of 300gf shall be applied to the tip of terminal in the desired direction for 1 minute. The number of tests shall be once per terminal.  | Shall be free from terminal looseness and damage and breakage of terminal Holding portion.  |
|                        | 7  | Control Strength          | 1) A static load of 500gf shall be applied in the operating direction of the slider for 1 minute.<br>2) A static load of 150gf shall be applied to the slider in the vertical direction of operation for 1 minute.   | 1) Contact resistance: 10Ω Max.<br>2) Insulation resistance: 10MΩ Min.<br>3) Withstand voltage: 250VAC for 1 minute<br>4) Operating force: within ±30% of initial Value.<br>5) Appearance: every part should not defect in appearance |
|                        | 8  | Solderability             | Switch shall be checked after following test:<br>1) Soldering temperature: 260±5°C<br>2) Dipping time: 3±0.5 sec.  | More than 90% of Immersed part shall be covered with Solder. Excluding the cutting surface.   |
|                        | 9  | Soldering Heat Resistance | Switch shall be measured after following test.<br>1) Hand soldering temperature: 350°C Max.<br>Time: 3 seconds Max.<br>2) Reflow soldering: 2 times or less<br><br>Above mentions time-temperature Chart is based on the temperature on The parts-mounting surface of PCB. | 1) Contact resistance: 10Ω Max.<br>2) Insulation resistance: 10MΩ Min.<br>3) Withstand voltage: 250VAC for 1 minute<br>4) Operating force: within ±30% of initial Value.<br>5) Appearance: every part should not defect in appearance |
| Durability             | 10 | Operating Life            | Tested as follows:<br>1) Rate of operation: 15 to 20 operations per minute.<br>2) Cycle of operation: 100,000 cycles Min.  | 1) Contact resistance: 10Ω Max.<br>2) Insulation resistance: 10MΩ Min.<br>3) Withstand voltage: 250VAC for 1 minute<br>4) Operating force: within ±30% of initial Value.<br>5) Appearance: every part should not defect in appearance |

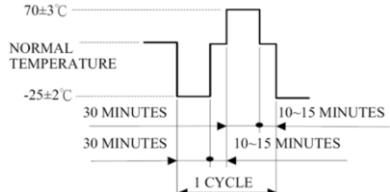
|                     |    |                        |  |  |
|---------------------|----|------------------------|--|--|
| Weather Performance | 11 | Humidity Resistance    | Testing switch being kept in the conditions at $65\pm 2^{\circ}\text{C}$ and 90 to 95% RH for 96 hours, then in a normal ambient condition for 1 hour, then to be measured within 1 hour.  | 1) Contact resistance: $10\Omega$ Max.<br>2) Insulation resistance: $10\text{M}\Omega$ Min.<br>3) Withstand voltage: 250VAC for 1 minute<br>4) Operating force: within $\pm 30\%$ of initial Value.<br>5) Appearance: every part should not defect in appearance |
|                     | 12 | Heat Resistance        | Testing switch being kept in the Conditions at $80\pm 2^{\circ}\text{C}$ in temperature for 96 hours, then in a normal ambient condition for 1 hour, then to be measured within 1 hour.  |  |
|                     | 13 | Cold Resistance        | Testing switch being kept in the conditions at $-40\pm 2^{\circ}\text{C}$ in temperature for 96 hours, then in a normal ambient condition for 1 hour, then to be measured within 1 hour. Water drops shall be removed.   |  |
|                     | 14 | Temperature Cycle Test | After 5 cycles of following conditions, the Switch shall be allowed to stand under Normal temperature and humidity conditions for 1 hour, and water drops Shall be removed.<br> |  |

■ Precautions in Handling

1. Care must be taken to ensure excess flux on the top surface of the printed circuit board does not adhere to the switch.
2. Do not wash the switch.

■ Recommended storage conditions:

Store the products in the original packaging material. After opening the package, the remaining products must be stored in the appropriate moisture-proof & airtight environment.

Do not store the switch in the following environment or it may affect performance and solderability:

1. temperatures below  $-10^{\circ}\text{C}$  to  $40^{\circ}\text{C}$  & humidity at 85% (min)
2. environment with corrosive gas
3. storage over 6 months
4. place in direct sunlight

## How to order

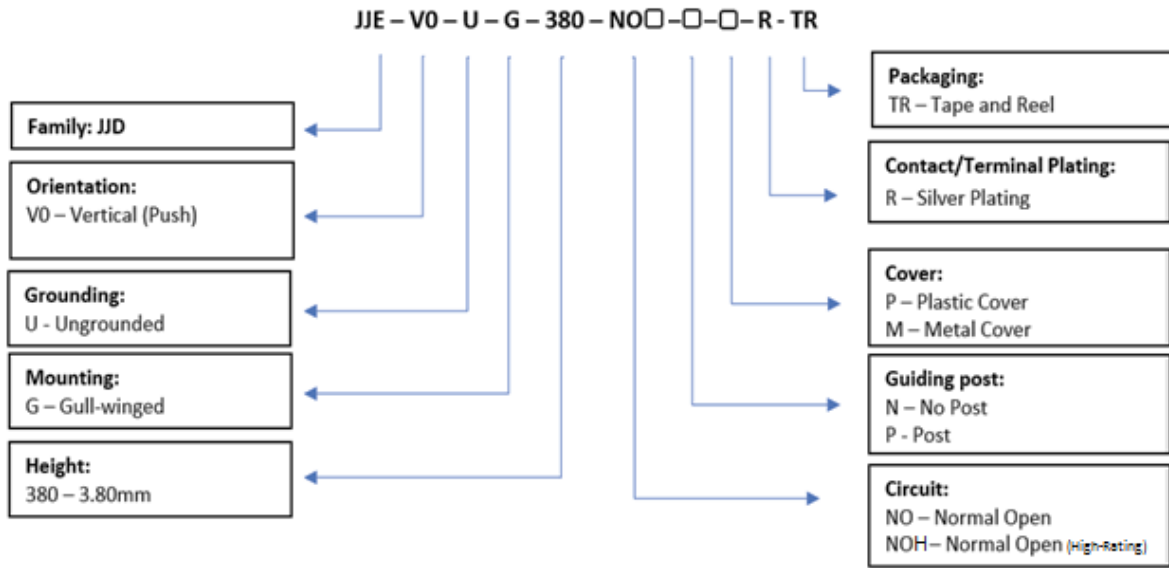

## PN List

| Smart PN            | Orientation   | Grounding  | Mounting    | Height | Circuit | Guiding Post | Cover | Plating | Packaging     | MOQ   | TE PN     |
|---------------------|---------------|------------|-------------|--------|---------|--------------|-------|---------|---------------|-------|-----------|
| JJEV0UG380NOHPMRTR  | Vertical Push | Ungrounded | Gull-winged | 3.80mm | NOH     | Post         | Metal | Silver  | Tape and Reel | 1,800 | 2331394-1 |
| JJEV0UG380NOHNMTRTR | Vertical Push | Ungrounded | Gull-winged | 3.80mm | NOH     | No Post      | Metal | Silver  | Tape and Reel | 1,800 | 2331395-1 |
| JJEV0UG380NONMTRTR  | Vertical Push | Ungrounded | Gull-winged | 3.80mm | NO      | No Post      | Metal | Silver  | Tape and Reel | 3,000 | 2331417-1 |



Компания «ЭлектроПласт» предлагает заключение долгосрочных отношений при поставках импортных электронных компонентов на взаимовыгодных условиях!

Наши преимущества:

- Оперативные поставки широкого спектра электронных компонентов отечественного и импортного производства напрямую от производителей и с крупнейших мировых складов;
- Поставка более 17-ти миллионов наименований электронных компонентов;
- Поставка сложных, дефицитных, либо снятых с производства позиций;
- Оперативные сроки поставки под заказ (от 5 рабочих дней);
- Экспресс доставка в любую точку России;
- Техническая поддержка проекта, помощь в подборе аналогов, поставка прототипов;
- Система менеджмента качества сертифицирована по Международному стандарту ISO 9001;
- Лицензия ФСБ на осуществление работ с использованием сведений, составляющих государственную тайну;
- Поставка специализированных компонентов (Xilinx, Altera, Analog Devices, Intersil, Interpoint, Microsemi, Aeroflex, Peregrine, Syfer, Eurofarad, Texas Instrument, Miteq, Cobham, E2V, MA-COM, Hittite, Mini-Circuits, General Dynamics и др.);

Помимо этого, одним из направлений компании «ЭлектроПласт» является направление «Источники питания». Мы предлагаем Вам помощь Конструкторского отдела:

- Подбор оптимального решения, техническое обоснование при выборе компонента;
- Подбор аналогов;
- Консультации по применению компонента;
- Поставка образцов и прототипов;
- Техническая поддержка проекта;
- Защита от снятия компонента с производства.



#### Как с нами связаться

**Телефон:** 8 (812) 309 58 32 (многоканальный)

**Факс:** 8 (812) 320-02-42

**Электронная почта:** [org@eplast1.ru](mailto:org@eplast1.ru)

**Адрес:** 198099, г. Санкт-Петербург, ул. Калинина, дом 2, корпус 4, литера А.