

Subminiature, Waterproof Duplex Fiber Optic Connectors

MF10S Series

Waterproof (IP67)

2 Positions

Screw Locking System



■ Features

1. Compact size

Using the widely accepted MU connector ferrule (1.25 mm dia.), assembled in a one-piece shell and internal housing, the waterproof connectors can be used in space-restricted applications.

2. Used in harsh outdoor environments

Tested for 500 hour in salt-fog the connectors are IP67 rated, fully mated or with protective caps.

3. High intensity fiber optic cable

Typical FO cable is the light weight and flexible 6.5 mm outside diameter military type.

Other types of cables can be also accommodated (consult Hirose).

4. Coupling wrench

Optional coupling wrench can be provided to assure that the mated connectors are securely tightened to a specified torque range of 1.5 to 3 N·m.



■ Applications

Variety of outdoor optical transmission systems including large LED controllers, surveillance cameras, base stations, railway monitoring, meteorological outdoor instrumentation and other harsh-environment outdoor applications requiring reliable FO connections.

● Flange variations

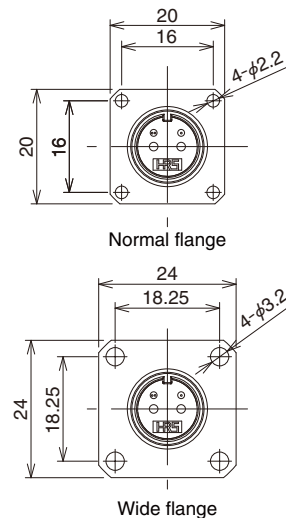

Product Specifications

Ratings	Operating temperature range	-40°C to +85°C	Storage temperature range	-25°C to +75°C (At packing)
---------	-----------------------------	----------------	---------------------------	-----------------------------

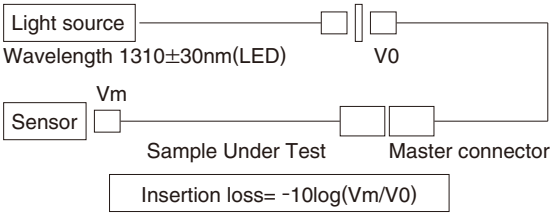
Item	Test method	Specifications
Optical characteristics	 <p>Light source Wavelength 1310±30nm(LED) V0 Sensor Vm Sample Under Test Master connector Insertion loss= -10log(Vm/V0)</p>	SM : 1.4dB max. (Average 0.3dB) MM : 0.7dB max. (Average 0.1dB) (Note)
Mechanical characteristics	Cable retention (Straight pull) : 200N tensile loads Durability (mating/un-mating) : 200 times Vibration : Frequency : 10 to 55Hz, single amplitude of 0.75mm, acceleration of 98.1 m/s ² , 2 hours in each of the 2 axis. Shock : Acceleration of 981m/s ² , 6ms duration, sine half-wave waveform, 3 cycles in each of the 2 axis.	1) Insertion loss fluctuation after test: 0.3dB max. 2) No visible damage or components dislocation.
Environmental characteristics	Humidity (Temperature/humidity-cycles) : -10°C to +65°C, humidity : 90% to 96% 10 cycles (240 hours) Temperature cycle : -40°C to +75°C, 42 cycles Dry heat : 240 hours at +85°C Cold : 240 hours at -40°C Salt mist : 500 hours (chrome plating), 240 hours (nickel plating) in a 5% concentration of salt mist Water proof : 1 minute at internal air pressure of 4.9 kPa	1) Insertion loss fluctuation after test: 0.3dB max. 2) No visible damage or components dislocation. No corrosion. No air leakage

Note : Total insertion loss of connection (plug, receptacle and master cord). (Multi-Mode : Used 1.5dB mode scrambler)

Materials / Finish

Part	Material	Finish/Color	Remarks
Plug and receptacle housing	Zinc alloy	Chrome plated (Black) or nickel plated	————
	Brass	Chrome plated (Black) or nickel plated	————
	Aluminum alloy	Alumite (Black)	————
Retainer plate	Synthetic resin	————	UL94V-0
Hole cap	Aluminum alloy	Alumite (Black)	————
Screws, ball chain	Stainless steel	————	————
Spring	Steel alloy	Zinc plated	————
Split sleeve	Zirconia	————	————
Coupling wrench (Optional)	Plastic	Blue	————

■ Plug housings

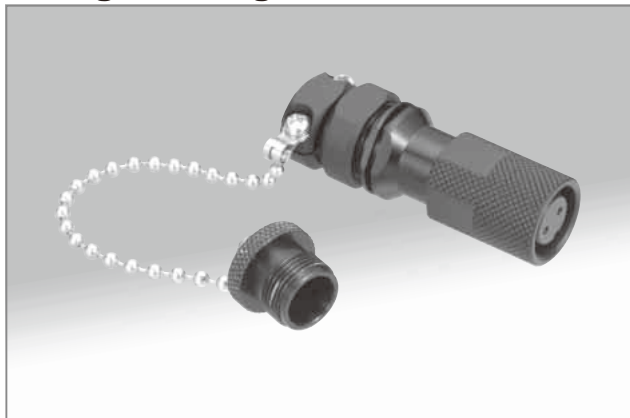

Part No.	HRS No.	Plating
MF10S-WP7C01-0200(31)*	709-0203-2 31	Cr
MF10S-WPN7C01-0200(31)*	709-0544-3 31	Ni

■ Receptacle housings

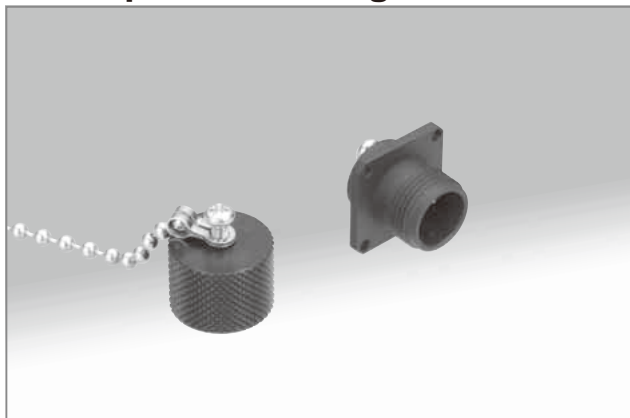

Part No.	HRS No.	Plating*	Flange*
MF10S-WDRF01-0200(31)	709-0204-5 31	Cr	N
MF10S-WDRFN01-0200(31)	709-0548-4 31	Ni	N
MF10S-WDRFNG01-0200(31)	709-0549-7 31	Ni	W
MF10S-WDRFG01-0200(31)	709-0578-5 31	Cr	W

Notes *

Cr : Chrome plating (Black), Ni : Nickel plating
 N : Normal flange, W : Wide flange

■ Coupling wrench (Optional)

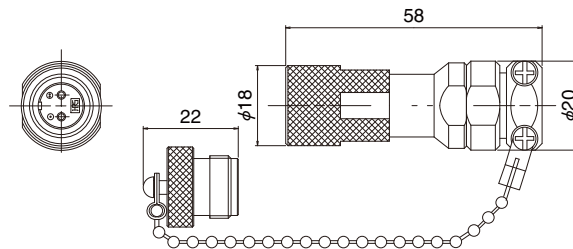

Normal flange

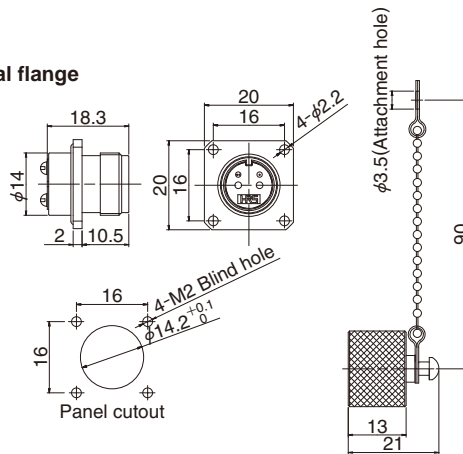

Wide flange

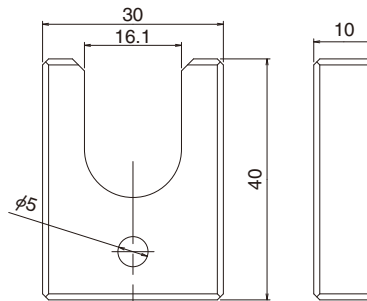
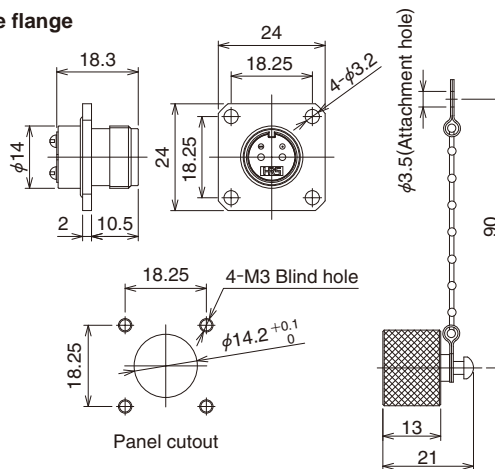

Part No.	HRS No.
MF10-T1	709-0205-8 00



Компания «ЭлектроПласт» предлагает заключение долгосрочных отношений при поставках импортных электронных компонентов на взаимовыгодных условиях!

Наши преимущества:

- Оперативные поставки широкого спектра электронных компонентов отечественного и импортного производства напрямую от производителей и с крупнейших мировых складов;
- Поставка более 17-ти миллионов наименований электронных компонентов;
- Поставка сложных, дефицитных, либо снятых с производства позиций;
- Оперативные сроки поставки под заказ (от 5 рабочих дней);
- Экспресс доставка в любую точку России;
- Техническая поддержка проекта, помощь в подборе аналогов, поставка прототипов;
- Система менеджмента качества сертифицирована по Международному стандарту ISO 9001;
- Лицензия ФСБ на осуществление работ с использованием сведений, составляющих государственную тайну;
- Поставка специализированных компонентов (Xilinx, Altera, Analog Devices, Intersil, Interpoint, Microsemi, Aeroflex, Peregrine, Syfer, Eurofarad, Texas Instrument, Miteq, Cobham, E2V, MA-COM, Hittite, Mini-Circuits, General Dynamics и др.);

Помимо этого, одним из направлений компании «ЭлектроПласт» является направление «Источники питания». Мы предлагаем Вам помощь Конструкторского отдела:

- Подбор оптимального решения, техническое обоснование при выборе компонента;
- Подбор аналогов;
- Консультации по применению компонента;
- Поставка образцов и прототипов;
- Техническая поддержка проекта;
- Защита от снятия компонента с производства.



Как с нами связаться

Телефон: 8 (812) 309 58 32 (многоканальный)

Факс: 8 (812) 320-02-42

Электронная почта: org@eplast1.ru

Адрес: 198099, г. Санкт-Петербург, ул. Калинина, дом 2, корпус 4, литера А.