

TPC-651T

5.7"/6.5" VGA TFT LED LCD Intel® Atom™ Thin Client Terminals

NEW

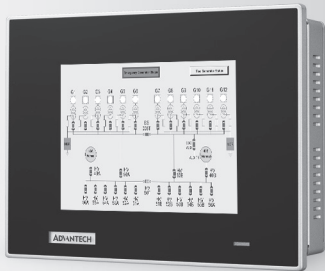

Features

- Industrial 5.7"/6.5" VGA TFT LCD with 50K Lifetime LED Backlight
- Intel® Atom™ E3827 1.75 GHz Dual-core Processor with 4GB DDR3L SDRAM
- Support wide operating temperatures -20~60°C
- True-flat with IP66 certified front panel protection
- Front LED Indicator to Show Operating Status
- Durable 5-wire Resistive Touch Screen
- Supports iDoor technology for diverse applications (optional accessory required)
- Compact Fanless Embedded System with Al Alloy Front Bezel, Chassis Grounding Protection
- AC/DC support with optional Power adapter
- Supports Advantech WISE-PaaS/RMM Remote Device Management Software

Introduction

The TPC-651T thin client terminal with a 5.7"/6.5" VGA LCD, low power embedded Intel® Atom™ E3827 1.75 GHz Dual-core Processor and 4GB DDR3L SDRAM provides computing performance in a compact fanless system. To enhance its durability, the TPC-651T is true-flat touch screen designed with IP66 front protection, die-cast Al Alloy front bezel and 5-wire resistive touch. It supports wide operating temperatures -20~60°C and includes full size mini-PCIe slot to extend the functionality and meet a variety of automation applications needs. Through the Mini-PCIe slot, Advantech iDoor technology (optional) can provide more I/O connectors, Isolated Digital IO, the Fieldbus Protocol, 3G/GPS/GPRS/WiFi Communication and MRAM.

Specifications

General

- **BIOS** AMI UEFI
- **Certification** BSMI, CCC, CE, FCC Class A, UL
- **Cooling System** Fanless design
- **Dimensions (W x H x D)** 199 x 152 x 58.9 mm (7.83" x 5.98" x 2.32")
- **Enclosure** Front bezel: Die-cast Aluminum alloy
Back housing: SECC
- **Mounting** Desktop, Wall or Panel Mount
- **OS Support** Microsoft® WES7 32bit/64bit / WE8S 64bit / Windows 7 / 8.1 32bit/64bit / Windows 10 Enterprise LTSB
- **Power Consumption** 19.2 W (typical)
- **Power Input** 24V_{DC} +/- 20%
- **Watchdog Timer** 1 ~ 255 sec (system)
- **Weight (Net)** 1.5 KG

System Hardware

- **CPU** Intel® Atom™ E3827 1.75 GHz Dual-core Processor
- **Memory** 1 x SO-DIMM with 4GB DDR3L SDRAM (supports up to 8G)
- **LAN** 10/100/1000 Base-T x 2
- **Expansion Slots** Full-size Mini PCI-E
- **Storage** CFast slot x 1
2.5" SATA SSD slot x 1 (optional)
- **I/O** RS-232 x 1, RS-232/422/485 x 1
USB 3.0 x 1
USB 2.0 x 1

LCD Display

- **Display Type** VGA TFT LED LCD
- **Display Size** 5.7"/6.5"
- **Max. Resolution** 640 x 480
- **Max. Colors** 262K
- **Luminance cd/m²** 550/800
- **Viewing Angle (H/V°)** 160/140
- **Backlight Life** 50,000 hrs
- **Contrast Ratio** 800:1/600:1

Touchscreen

- **Lifespan** 36 million touches at single point
- **Light Transmission** Above 75%
- **Resolution** Linearity
- **Type** 5-wire, analog resistive

Environment

- **Humidity** 10 ~ 95% RH @ 40°C, non-condensing
- **Ingress Protection** Front panel: IP66
- **Operating Temperature** -20 ~ 60°C (-4 ~ 140°F)
- **Storage Temperature** -30 ~ 70°C (-22 ~ 158°F)
- **Vibration Protection** With CFast: 2 Grms (5~500 Hz)
With HDD: 1 Grms (5 ~ 500 Hz)
(Operating, random vibration)

Rear View

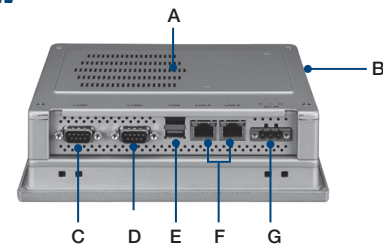

- A. External HDD/SSD/iDoor kit (TPC-1251T-EHKE) (Optional)
- B. CFast
- C. RS-232
- D. RS-232/422/485
- E. USB 3.0 & 2.0
- F. LAN (10/100/1000)
- G. Power Receptor

Dimensions

Unit: mm

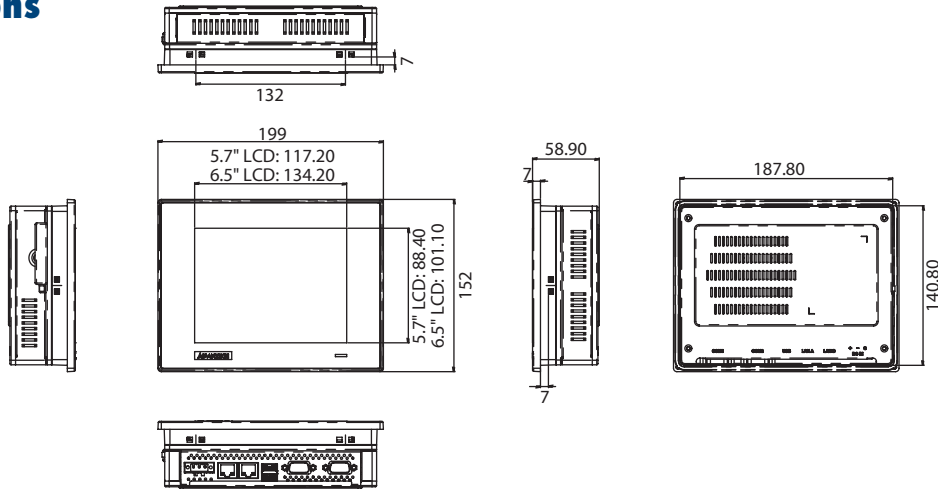

Panel Cut-out Dimensions: 189.1 x 142.1 mm (7.44" x 5.59")

Ordering Information

- **TPC-651T-E3AE** 5.7" VGA Panel PC, Intel® Atom™ E3827 1.75 GHz Dual-core Processor, 4GB (True-flat touch screen)
- **TPC-651H-E3AE** 5.7" VGA Panel PC, Intel® Atom™ E3827 1.75 GHz Dual-core Processor, 4GB (Non-flat touch screen IP65 certified traditional TPC front panel)
- **TPC-651T-6E3AE** 6.5" VGA Panel PC, Intel® Atom™ E3827 1.75 GHz Dual-core Processor, 4GB (True-flat touch screen)

Optional Accessories

- **PWR-247-CE** 60W DC 24V/2.5A Output Power Supply
- **TPC-1251T-EHKE** HDD/SSD and iDoor extension kit
- **1702002600** Power Cable US Plug 1.8 M
- **1702002605** Power Cable EU Plug 1.8 M
- **1702031801** Power Cable UK Plug 1.8 M
- **1700000596** Power Cable China/Australia Plug 1.8 M

Embedded O/S

- **2070014327** TPC-xx51T/H WS7P x64 MUI Image v4.14
- **2070013613** TPC-xx51T/H WS7P x86 MUI Image v4.12
- **2070013845** TPC-651T/H WEC7 x64 MUI Image V4.00
- **2070014400** TPC-xx51T/H Win10 Enterprise LTSB x64 MUI image v6.00 B002

S/W Bundle Offering

- **WA-HT651T-E15H1AE** TPC-651T-6E3AE, HMI Runtime 1500 tags, 32G CFast, WES7P

iDoor Modules

(TPC-1251T-EHKE is required for iDoor modules)

- **PCM-26D2CA-AE** SJA1000 CANBus, CANOpen, DB9 x 2
- **PCM-26D1DB-MAE** Hilscher netX100 FieldBus, ProfiBus, DB9 x 1
- **PCM-27D24DI-AE** Digital I/O, 16 DI / 8 DO, Isolation, DB37 x 1
- **PCM-24D2R4-AE** OXPcie-952 UART, Isolated RS-422/485, DB9 x 2
- **PCM-24D2R2-AE** OXPcie-952 UART, Isolated RS-232, DB9 x 2
- **PCM-24R2GL-AE** 2 Port Giga LAN Intel i350 PCIe mini card
- **PCM-24R1TP-AE** Intel 82574L, GbE, IEEE 1588 PTP, RJ45 x 1
- **PCM-24S2WF-AE** 802.11 a/b/g/n 2T2R w/ BT4.0, Atheros AR9462

Application Software

WebAccess/SCADA	Advantech WebAccess is a 100% web based SCADA (Supervisory Control And Data Acquisition) software and it acts as an IIoT Platform providing open interfaces for partners to develop IoT applications for different vertical markets. In addition to traditional SCADA functions, WebAccess has an intelligent Dashboard, to provide users with cross-platform, cross-browser data analysis and user interface using HTML5 technology. As well as the built-in widgets, WebAccess also provides Widget Builder to allow customers to build their own.
WebAccess/HMI	WebAccess/HMI is Human Machine Interface (HMI) software based on Microsoft's Windows operating system. It utilizes a PC's ample resources, ie speed, storage, multimedia, peripheral devices, and large screen to produce a complex human-machine interface. WebAccess/HM with its communication and monitoring ability supports more than 350 PLC communication protocols and a wide choice of screen design objects, to satisfy multiple integrations of factory automation and all-round human-machine interface operation and monitoring requirements.



Компания «ЭлектроПласт» предлагает заключение долгосрочных отношений при поставках импортных электронных компонентов на взаимовыгодных условиях!

Наши преимущества:

- Оперативные поставки широкого спектра электронных компонентов отечественного и импортного производства напрямую от производителей и с крупнейших мировых складов;
- Поставка более 17-ти миллионов наименований электронных компонентов;
- Поставка сложных, дефицитных, либо снятых с производства позиций;
- Оперативные сроки поставки под заказ (от 5 рабочих дней);
- Экспресс доставка в любую точку России;
- Техническая поддержка проекта, помощь в подборе аналогов, поставка прототипов;
- Система менеджмента качества сертифицирована по Международному стандарту ISO 9001;
- Лицензия ФСБ на осуществление работ с использованием сведений, составляющих государственную тайну;
- Поставка специализированных компонентов (Xilinx, Altera, Analog Devices, Intersil, Interpoint, Microsemi, Aeroflex, Peregrine, Syfer, Eurofarad, Texas Instrument, Miteq, Cobham, E2V, MA-COM, Hittite, Mini-Circuits, General Dynamics и др.);

Помимо этого, одним из направлений компании «ЭлектроПласт» является направление «Источники питания». Мы предлагаем Вам помощь Конструкторского отдела:

- Подбор оптимального решения, техническое обоснование при выборе компонента;
- Подбор аналогов;
- Консультации по применению компонента;
- Поставка образцов и прототипов;
- Техническая поддержка проекта;
- Защита от снятия компонента с производства.



Как с нами связаться

Телефон: 8 (812) 309 58 32 (многоканальный)

Факс: 8 (812) 320-02-42

Электронная почта: org@eplast1.ru

Адрес: 198099, г. Санкт-Петербург, ул. Калинина, дом 2, корпус 4, литера А.