

### General Description

The Micrel MIC2177 is a 200kHz synchronous buck (step-down) switching regulator designed for high-efficiency, battery-powered applications.

The MIC2177 operates from a 4.5V to 16.5V input and features internal power MOSFETs that can supply up to 2.5A output current. It can operate with a maximum duty cycle of 100% for use in low-dropout conditions. It also features a shutdown mode that reduces quiescent current to less than 5 $\mu$ A.

The MIC2177 achieves high efficiency over a wide output current range by switching between PWM and skip mode. Operating mode is automatically selected according to output conditions. Switching frequency is preset to 200kHz and can be synchronized to an external clock signal of up to 300kHz.

The MIC2177 uses current-mode control with internal current sensing. Current-mode control provides superior line regulation and makes the regulator control loop easy to compensate. The output is protected with pulse-by-pulse current limiting and thermal shutdown. Undervoltage lockout turns the output off when the input voltage is less than 4.5V.

The MIC2177 is packaged in a 20-pin wide power SO package with an operating temperature range of -40°C to +85°C.

See the MIC2178 for externally selected PWM or skip-mode operation.

Data sheets and support documentation can be found on Micrel's web site at: [www.micrel.com](http://www.micrel.com).

### Features

- 4.5V to 16.5V input voltage range
- Dual-mode operation for high efficiency (up to 96%)
  - PWM mode for > 200mA load current
  - Skip mode for < 200mA load current
- 100m $\Omega$  internal power MOSFETs at 12V input
- 200kHz preset switching frequency
- Low quiescent current
  - 1.0mA in PWM mode
  - 500 $\mu$ A in skip mode
  - < 5 $\mu$ A in shutdown mode
- 100% duty cycle for low dropout operation
- Current-mode control
  - Simplified loop compensation
  - Superior line regulation
- Current limit
- Thermal shutdown
- Undervoltage lockout

### Applications

- High-efficiency, battery-powered supplies
- Buck (step-down) dc-to-dc converters
- Cellular telephones
- Laptop computers
- Hand-held instruments
- Battery Charger

### Typical Application

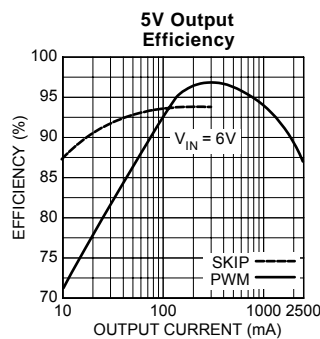
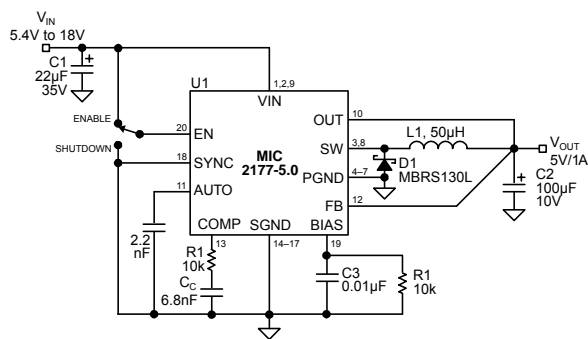

### Ordering Information

Part Number	Output Voltage	Switching Frequency	Temperature Range	Package	Lead Finish
MIC2177-3.3BWM	3.3V	200kHz	-40°C to +85°C	20-Pin Wide SOIC	Standard
MIC2177-5.0BWM	5.0V	200kHz	-40°C to +85°C	20-Pin Wide SOIC	Standard
MIC2177BWM	Adj.	200kHz	-40°C to +85°C	20-Pin Wide SOIC	Standard
MIC2177-3.3YWM	3.3V	200kHz	-40°C to +85°C	20-Pin Wide SOIC	Pb-Free

### Pin Configuration

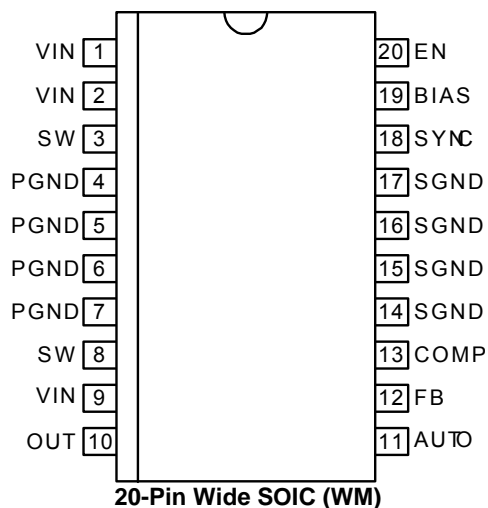

## Pin Description

Pin Number	Pin Name	Pin Function
1, 2, 9	VIN	Supply Input: Controller and switch supply. Unregulated supply input to internal regulator, output switches, and control circuitry. Requires bypass capacitor to PGND. All three pins must be connected to VIN.
3, 8	SW	Switch (Output): Internal power MOSFET switch output. Both pins must be externally connected together.
4, 5, 6, 7	PGND	Power Ground: Output stage ground connections. Connect all pins to a common ground plane.
10	OUT	Output Voltage Sense (Input): Senses output voltage to determine minimum switch current for PWM operation. Connect directly to VOUT.
11	AUTO	Automatic Mode: Connect 2.2nF timing capacitor for automatic PWM-/skip-mode switching. Regulator operates exclusively in PWM mode when pin is pulled low.
12	FB	Feedback (Input): Error amplifier inverting input. For adjustable output version, connect FB to external resistive divider to set output voltage. For 3.3V and 5V fixed output versions, connect FB directly to output.
13	COMP	Compensation: Internal error amplifier output. Connect to capacitor or series RC network to compensate the regulator control loop.
14, 15, 16, 17	SGND	Signal Ground: Ground connection of control section. Connect all pins to common ground plane.
18	SYNC	Frequency Synchronization (Input): Optional clock input. Connect to external clock signal to synchronize oscillator. Leading edge of signal above 1.7V terminates switching cycle. Connect to SGND if not used.
19	BIAS	Bias Supply: Internal 3.3V bias supply output. Decouple with 0.01 $\mu$ F bypass capacitor and 10k $\Omega$ to SGND. Do not apply any external load.
20	EN	Enable (Input): Logic high enables operation. Logic low shuts down regulator. Do not allow pin to float.

## Absolute Maximum Ratings

Supply Voltage [100ms transient] ( $V_{IN}$ )	18V
Output Switch Voltage ( $V_{SW}$ )	18V
Output Switch Current ( $I_{SW}$ )	6.0A
Enable, Output-Sense Voltage ( $V_{EN}$ , $V_{OUT}$ )	18V
Sync Voltage ( $V_{SYNC}$ )	6V

## Operating Ratings

Supply Voltage ( $V_{IN}$ )	4.5V to 16.5V
Junction Temperature ( $T_J$ )	-40°C to +125°C

## Electrical Characteristics

$V_{IN} = 7.0V$ ;  $T_A = 25^\circ C$ , **bold** values indicate  $-40^\circ C \leq T_A \leq +85^\circ C$ , unless noted.

Symbol	Parameter	Condition	Min	Typ	Max	Units
$I_{SS}$	Input Supply Current	PWM mode, output not switching, $4.5V \leq V_{IN} \leq 16.5V$		1.0	<b>1.5</b>	mA
		skip mode, output not switching, $4.5V \leq V_{IN} \leq 16.5V$		500	<b>650</b>	$\mu A$
		$V_{EN} = 0V$ , $4.5V \leq V_{IN} \leq 16.5V$		1	<b>25</b>	$\mu A$
$V_{BIAS}$	Bias Regulator Output Voltage	$V_{IN} = 16.5V$	<b>3.10</b>	3.30	<b>3.40</b>	V
$V_{FB}$	Feedback Voltage	MIC2177 [adj.]: $V_{OUT} = 3.3V$ , $I_{LOAD} = 0$	<b>1.22</b>	1.245	<b>1.27</b>	V
$V_{OUT}$	Output Voltage	MIC2177 [adj.]: $V_{OUT} = 3.3V$ , $5V \leq V_{IN} \leq 16V$ , $10mA \leq I_{LOAD} \leq 2A$	3.20 <b>3.14</b>	3.3	3.40 <b>3.46</b>	V V
		MIC2177-5.0: $I_{LOAD} = 0$	<b>4.85</b>	5.0	<b>5.15</b>	V
		MIC2177-5.0: $6V \leq V_{IN} \leq 16V$ , $10mA \leq I_{LOAD} \leq 2A$	4.85 <b>4.75</b>	5.0	5.15 <b>5.25</b>	V V
		MIC2177-3.3: $I_{LOAD} = 0$	<b>3.20</b>	3.3	<b>3.40</b>	V
		MIC2177-3.3: $5V \leq V_{IN} \leq 16V$ , $10mA \leq I_{LOAD} \leq 2A$	3.20 <b>3.14</b>	3.3	3.40 <b>3.46</b>	V V
$V_{TH}$	Undervoltage Lockout	upper threshold		4.25	<b>4.35</b>	V
		lower threshold	<b>3.9</b>	4.15		V
$I_{FB}$	Feedback Bias Current	MIC2177 [adj.]		60	<b>150</b>	nA
		MIC2177-5.0, MIC2177-3.3		20	<b>40</b>	$\mu A$
$A_{VOL}$	Error Amplifier Gain	$0.6V \leq V_{COMP} \leq 0.8V$	<b>15</b>	18	<b>20</b>	V
	Error Amplifier Output Swing	upper limit	<b>0.9</b>	1.5		V
		Lower limit		0.05	<b>0.1</b>	V
	Error Amplifier Output Current	source and sink	<b>15</b>	25	<b>35</b>	$\mu A$
$f_O$	Oscillator Frequency		<b>160</b>	200	<b>240</b>	kHz
$D_{MAX}$	Maximum Duty Cycle	$V_{FB} = 1.0V$	<b>100</b>			%
$t_{ON\ min}$	Minimum On-Time	$V_{FB} = 1.5V$		300	<b>400</b>	ns
	SYNC Frequency Range		<b>220</b>		<b>300</b>	kHz
	SYNC Threshold		<b>0.8</b>	1.6	<b>2.2</b>	V
	SYNC Minimum Pulse Width		<b>500</b>			ns
$I_{SYNC}$	SYNC Leakage	$V_{SYNC} = 0V$ to 5.5V	<b>-1</b>	0.01	<b>1</b>	$\mu A$
$I_{LIM}$	Current Limit	PWM mode, $V_{IN} = 12V$	<b>3.8</b>	4.7	<b>5.7</b>	A
		skip mode		600		mA
$R_{ON}$	Switch On-Resistance	high-side switch, $V_{IN} = 12V$		90	<b>250</b>	m $\Omega$
		low-side switch, $V_{IN} = 12V$		110	<b>250</b>	m $\Omega$

Symbol	Parameter	Condition	Min	Typ	Max	Units
$I_{SW}$	Output Switch Leakage	$V_{SW} = 16.5V$		1	<b>10</b>	$\mu A$
	Enable Threshold		0.8	1.6	<b>2.2</b>	V
$I_{EN}$	Enable Leakage	$V_{EN} = 0V$ to 5.5V	<b>-1</b>	0.01	<b>1</b>	$\mu A$
	AUTO Threshold		<b>0.8</b>	1.6		V
	AUTO Source Current	$V_{FB} = 1.5V, V_{AUTO} < 0.8V$	<b>7</b>	11	<b>15</b>	$\mu A$
	Minimum Switch Current for PWM Operation	$V_{IN} - V_{OUT} = 0V$		220		mA
		$V_{IN} - V_{OUT} = 3V$		420		mA

**General Note:** Devices are ESD sensitive. Handling precautions recommended.

# Typical Characteristics

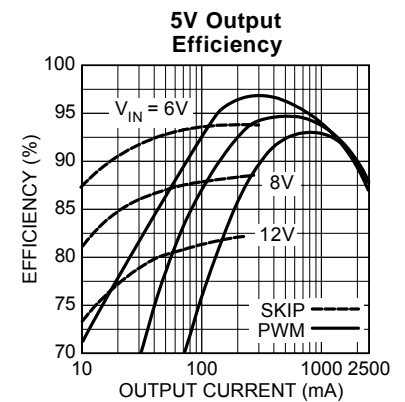
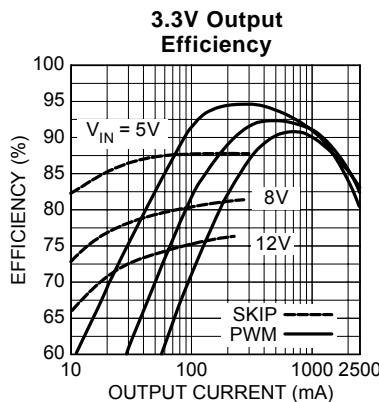
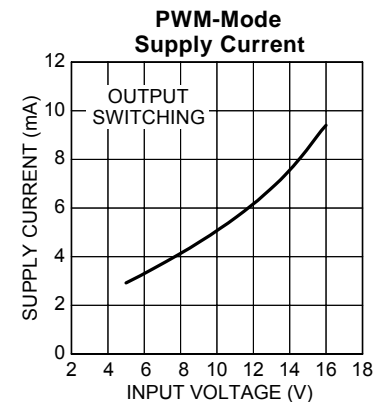
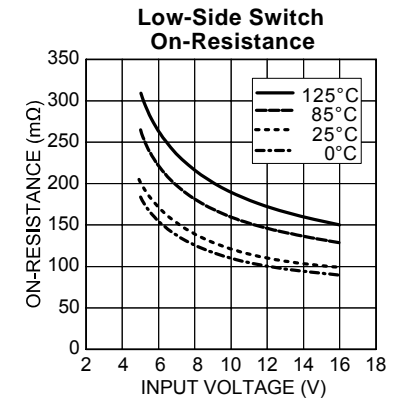
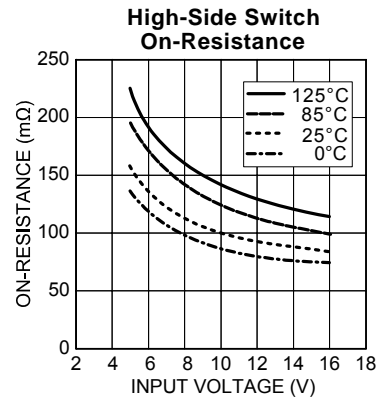
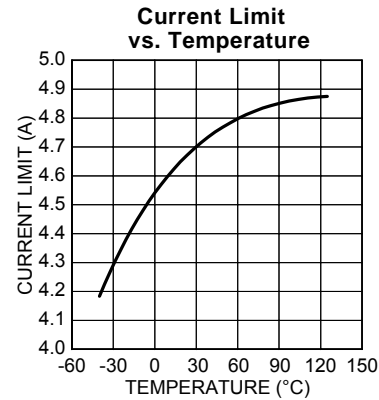
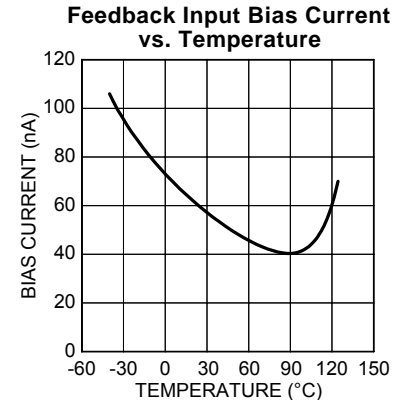
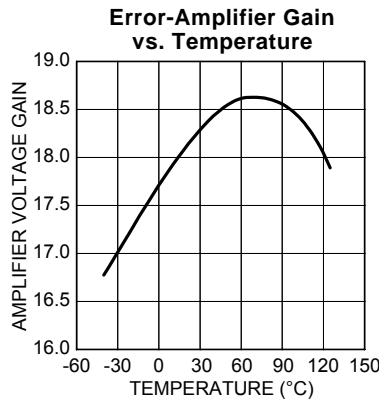
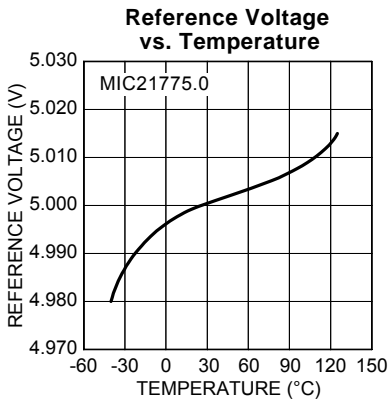
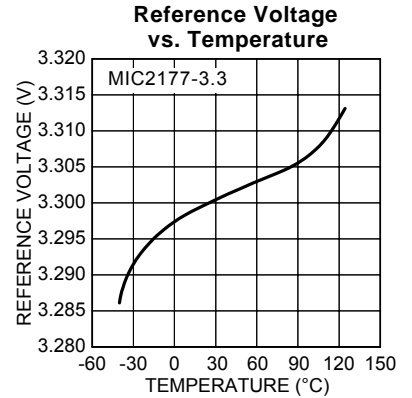
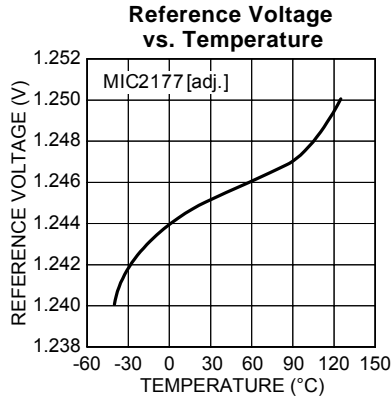
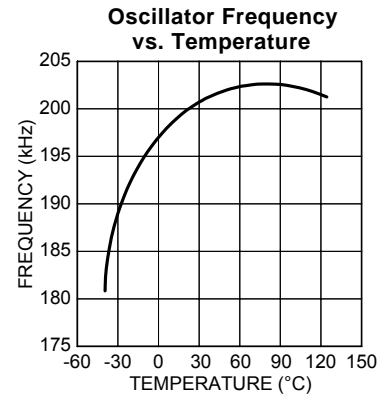

# Functional Diagram

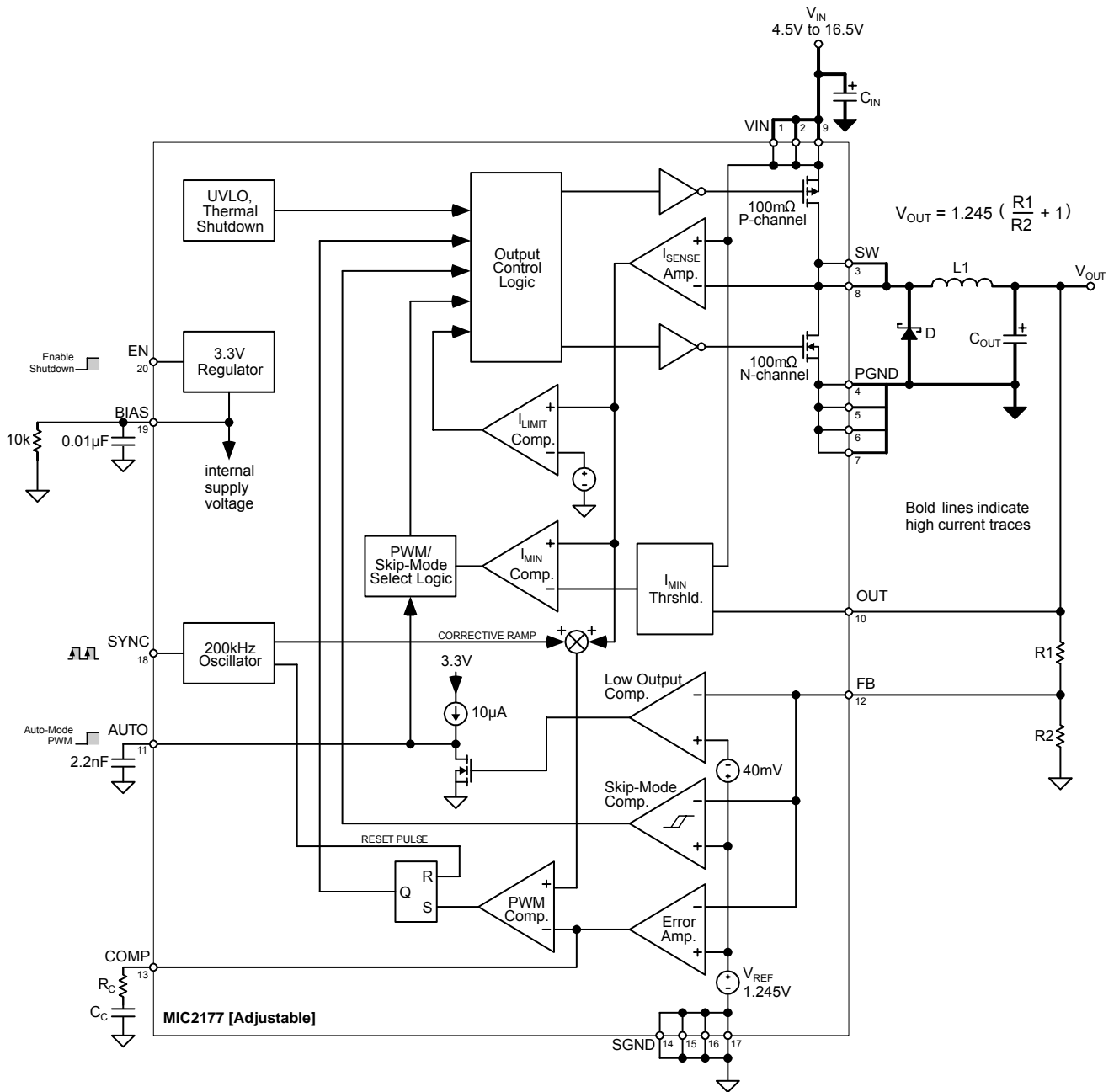

## Functional Description

Micrel's MIC2177 is a synchronous buck regulator that operates from an input voltage of 4.5V to 16.5V and provides a regulated output voltage of 1.25V to 16.5V. It has internal power MOSFETs that supply up to 2.5A of load current and operates with up to 100% duty cycle to allow low-dropout operation. To optimize efficiency, the MIC2177 operates in PWM and skip mode. Skip mode provides the best efficiency when load current is less than 200mA, while PWM mode is more efficient at higher current. A patented technique allows the MIC2177 to automatically select the correct operating mode as the load current changes.

During PWM operation, the MIC2177 uses current-mode control which provides superior line regulation and makes the control loop easier to compensate. The PWM switching frequency is set internally to 200kHz and can be synchronized to an external clock frequency up to 300kHz. Other features include a low-current shutdown mode, current limit, undervoltage lockout, and thermal shutdown. See the following sections for details.

### Switch Output

The switch output (SW) is a half H-bridge consisting of a high-side P-channel and low-side N-channel power MOSFET. These MOSFETs have a typical on-resistance of 100mΩ when the MIC2177 operates from a 12V supply. Anti-shoot-through circuitry prevents the P-channel and N-channel from turning on at the same time.

### Current Limit

The MIC2177 uses pulse-by-pulse current limiting to protect the output. During each switching period, a current limit comparator detects if the P-channel current exceeds 4.7A. When it does, the P-channel is turned off until the next switching period begins.

### Undervoltage Lockout

Undervoltage lockout (UVLO) turns off the output when the input voltage ( $V_{IN}$ ) is too low to provide sufficient gate drive for the output MOSFETs. It prevents the output from turning on until  $V_{IN}$  exceeds 4.3V. Once operating, the output will not shut off until  $V_{IN}$  drops below 4.2V.

### Thermal Shutdown

Thermal shutdown turns off the output when the MIC2177 junction temperature exceeds the maximum value for safe operation. After thermal shutdown occurs, the output will not turn on until the junction temperature drops approximately 10°C.

### Shutdown Mode

The MIC2177 has a low-current shutdown mode that is controlled by the enable input (EN). When a logic 0 is applied to EN, the MIC2177 is in shutdown mode and its quiescent current drops to less than 5μA.

### Internal Bias Regulator

An internal 3.3V regulator provides power to the MIC2177 control circuits. This internal supply is brought out to the BIAS pin for bypassing by an external 0.01μF capacitor. Do not connect any external load to the BIAS pin. It is not designed to provide an external supply voltage.

### Frequency Synchronization

The MIC2177 operates at a preset switching frequency of 200kHz. It can be synchronized to a higher frequency by connecting an external clock to the SYNC pin. The SYNC pin is a logic level input that synchronizes the oscillator to the rising edge of an external clock signal. It has a frequency range of 220kHz–300kHz, and can operate with a minimum pulse-width of 500ns. If synchronization is not required, connect SYNC to ground.

### Low-Dropout Operation

Output regulation is maintained in PWM or skip mode even when the difference between  $V_{IN}$  and  $V_{OUT}$  decreases below 1V. As  $V_{IN} - V_{OUT}$  decreases, the duty cycle increases until it reaches 100%. At this point, the P-channel is kept on for several cycles at a time, and the output stays in regulation until  $V_{IN} - V_{OUT}$  falls below the dropout voltage (dropout voltage = P-channel on resistance × load current).

### PWM-Mode Operation

Refer to “PWM-Mode Functional Diagram” which is a simplified block diagram of the MIC2177 operating in PWM mode with its associated waveforms.

When operating in PWM mode, the output P-channel and N-channel MOSFETs are alternately switched on at a constant frequency and variable duty cycle. A switching period begins when the oscillator generates a reset pulse. This pulse resets the RS latch which turns on the P-channel and turns off the N-channel. During this time, inductor current ( $I_{L1}$ ) increases and energy is stored in the inductor. The current sense amplifier ( $I_{SENSE}$  Amp) measures the P-channel drain-to-source voltage and outputs a voltage proportional to  $I_{L1}$ . The output of  $I_{SENSE}$  Amp is added to a saw tooth waveform (corrective ramp) generated by the oscillator, creating a composite waveform labeled  $I_{SENSE}$  on the timing diagram. When  $I_{SENSE}$  is greater than the error amplifier output, the PWM comparator will set the RS latch which turns off the P-channel and turns on the N-channel. Energy is then

discharged from the inductor and  $I_{L1}$  decreases until the next switching cycle begins. By varying the P-channel on-time (duty cycle), the average inductor current is adjusted to whatever value is required to regulate the output voltage.

The MIC2177 uses current-mode control to adjust the duty cycle and regulate the output voltage. Current-mode control has two signal loops that determine the duty cycle. One is an outer loop that senses the output voltage, and the other is a faster inner loop that senses the inductor current. Signals from these two loops control the duty cycle in the following way:  $V_{OUT}$  is fed back to the error amplifier which compares the feedback voltage ( $V_{FB}$ ) to an internal reference voltage ( $V_{REF}$ ). When  $V_{OUT}$  is lower than its nominal value, the error amplifier output voltage increases. This voltage then intersects the current-sense waveform later in switching period which increases the duty cycle and average inductor current. If  $V_{OUT}$  is higher than nominal, the error amplifier output voltage decreases, reducing the duty cycle.

The PWM control loop is stabilized in two ways. First, the inner signal loop is compensated by adding a corrective ramp to the output of the current sense amplifier. This allows the regulator to remain stable when operating at greater than 50% duty cycle. Second, a series resistor-capacitor load is connected to the error amplifier output (COMP pin). This places a pole-zero pair in the regulator control loop.

One more important item is synchronous rectification. As mentioned earlier, the N-channel output MOSFET is turned on after the P-channel turns off. When the N-channel turns on, its on-resistance is low enough to create a short across the output diode. As a result, inductor current flows through the N-channel and the voltage drop across it is significantly lower than a diode forward voltage. This reduces power dissipation and improves efficiency to greater than 95% under certain operating conditions.

To prevent shoot through current, the output stage employs break-before-make circuitry that provides approximately 50ns of delay from the time one MOSFET turns off and the other turns on. As a result, inductor current briefly flows through the output diode during this transition.

### Skip-Mode Operation

Refer to “Skip-Mode Functional Diagram” which is a simplified block diagram of the MIC2177 operating in skip mode and its associated waveforms.

Skip-mode operation turns on the output P-channel at a frequency and duty cycle that is a function of  $V_{IN}$ ,  $V_{OUT}$ , and the output inductor value. While in skip mode, the N-channel is kept off to optimize efficiency by reducing gate charge dissipation.  $V_{OUT}$  is regulated by skipping

switching cycles that turn on the P-channel.

To begin analyzing MIC2177 skip-mode operation, assume the skip-mode comparator output is high and the latch output has been reset to a logic 1. This turns on the P-channel and causes  $I_{L1}$  to increase linearly until it reaches a current limit of 600mA. When  $I_{L1}$  reaches this value, the current limit comparator sets the RS latch output to logic 0, turning off the P-channel. The output switch voltage ( $V_{SW}$ ) then swings from  $V_{IN}$  to 0.4V below ground, and  $I_{L1}$  flows through the Schottky diode.  $I_{L1}$  discharges its energy to the output and  $I_{L1}$  decreases to zero. When  $I_{L1} = 0$ ,  $V_{SW}$  swings from -0.4V to  $V_{OUT}$ , and this triggers a one-shot that resets the RS latch. Resetting the RS latch turns on the P-channel, which begins another switching cycle.

The skip-mode comparator regulates  $V_{OUT}$  by controlling when the MIC2177 skips cycles. It compares  $V_{FB}$  to  $V_{REF}$  and has 10mV of hysteresis to prevent oscillations in the control loop. When  $V_{FB}$  is less than  $V_{REF} - 5mV$ , the comparator output is logic 1, allowing the P-channel to turn on. Conversely, when  $V_{FB}$  is greater than  $V_{REF} + 5mV$ , the P-channel is turned off.

Note that this is a self-oscillating topology which explains why the switching frequency and duty cycle are a function of  $V_{IN}$ ,  $V_{OUT}$ , and the value of L1. It has the unique feature (for a pulse-skipping regulator) of supplying the same value of maximum load current for any value of  $V_{IN}$ ,  $V_{OUT}$ , or L1. This allows the MIC2177 to always supply up to 300mA of load current ( $I_{LOAD}$ ) when operating in skip mode.

### Changing from PWM to Skip Mode

Refer to “Block Diagram” for circuits described in the following sections.

The MIC2177 automatically changes from PWM to skip mode operation when  $I_{LOAD}$  drops below a minimum value.  $I_{MIN}$  is determined indirectly by detecting when the peak inductor current ( $I_{L(peak)}$ ) is less than 420mA. This is done by the minimum current comparator which detects if the output P-Channel current equals 420mA during each switching cycle. If it does not, the PWM/skip-mode select logic places the MIC2177 into skip-mode operation.

The value of  $I_{MIN}$  that corresponds to  $I_{L(peak)} = 420mA$  is given by the following equation:

$$I_{MIN} = \frac{420mA - \Delta I_{L1}}{2}$$

Where:

$\Delta I_{L1}$  = inductor ripple current

This equation shows  $I_{MIN}$  varies as a function of  $\Delta I_L$ . Therefore, the user must select an inductor value that results in  $I_{MIN} = 200mA$  when  $I_{L(peak)} = 420mA$ . The formulas for calculating the correct inductor value are

given in the “Applications Information” section. Note that  $\Delta I_L$  varies as a function of input voltage, and this also causes  $I_{MIN}$  to vary. In applications where the input voltage changes by a factor of two,  $I_{MIN}$  will typically vary from 130mA to 250mA.

During low-dropout operation, the minimum current thresh-old circuit reduces the minimum value of  $I_{L1(peak)}$  for PWM operation. This compensates for  $\Delta I_{L1}$  decreasing to almost zero when the difference between  $V_{IN}$  and  $V_{OUT}$  is very low.

#### Changing from Skip to PWM Mode

The MIC2177 will automatically change from skip to PWM mode when  $I_{LOAD}$  exceeds 300mA. During skip-mode operation, it can supply up to 300mA, and when  $I_{LOAD}$  exceeds this limit,  $V_{OUT}$  will fall below its nominal value. At this point, the MIC2177 begins operating in PWM mode. Note that the maximum value of  $I_{LOAD}$  for skip mode is greater than the minimum value required for PWM mode. This current hysteresis prevents the MIC2177 from toggling between modes when  $I_{LOAD}$  is in the range of 100mA to 300mA.

The low output comparator determines when  $V_{OUT}$  is low enough for the regulator to change operating modes. It detects when the feedback voltage is 3% below nominal, and pulls the AUTO pin to ground. When AUTO is less than 1.6V, the PWM/skip-mode select logic places the MIC2177 into PWM operation. The external 2.2nF capacitor connected to AUTO is charged by a 10 $\mu$ A current source after the regulator begins operating in PWM mode. As a result, AUTO stays below 1.6V for several switching cycles after PWM operation begins, forcing the MIC2177 to remain in PWM mode during this transition.

#### External PWM-Mode Selection

The MIC2177 can be forced to operate in only PWM mode by connecting AUTO to ground. This prevents skip-mode operation in applications that are sensitive to switching noise.

# PWM-Mode Functional Diagram

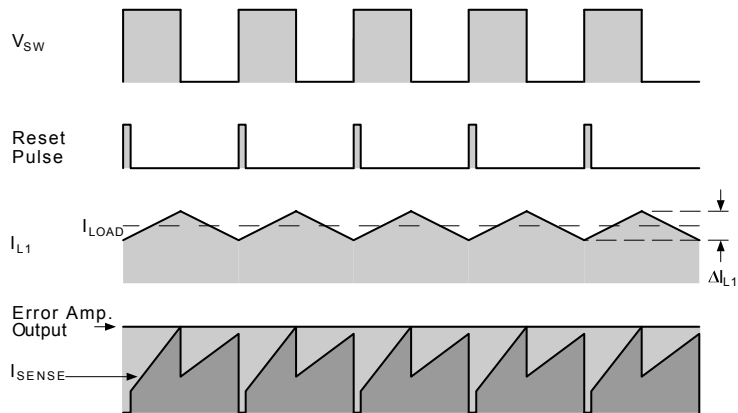
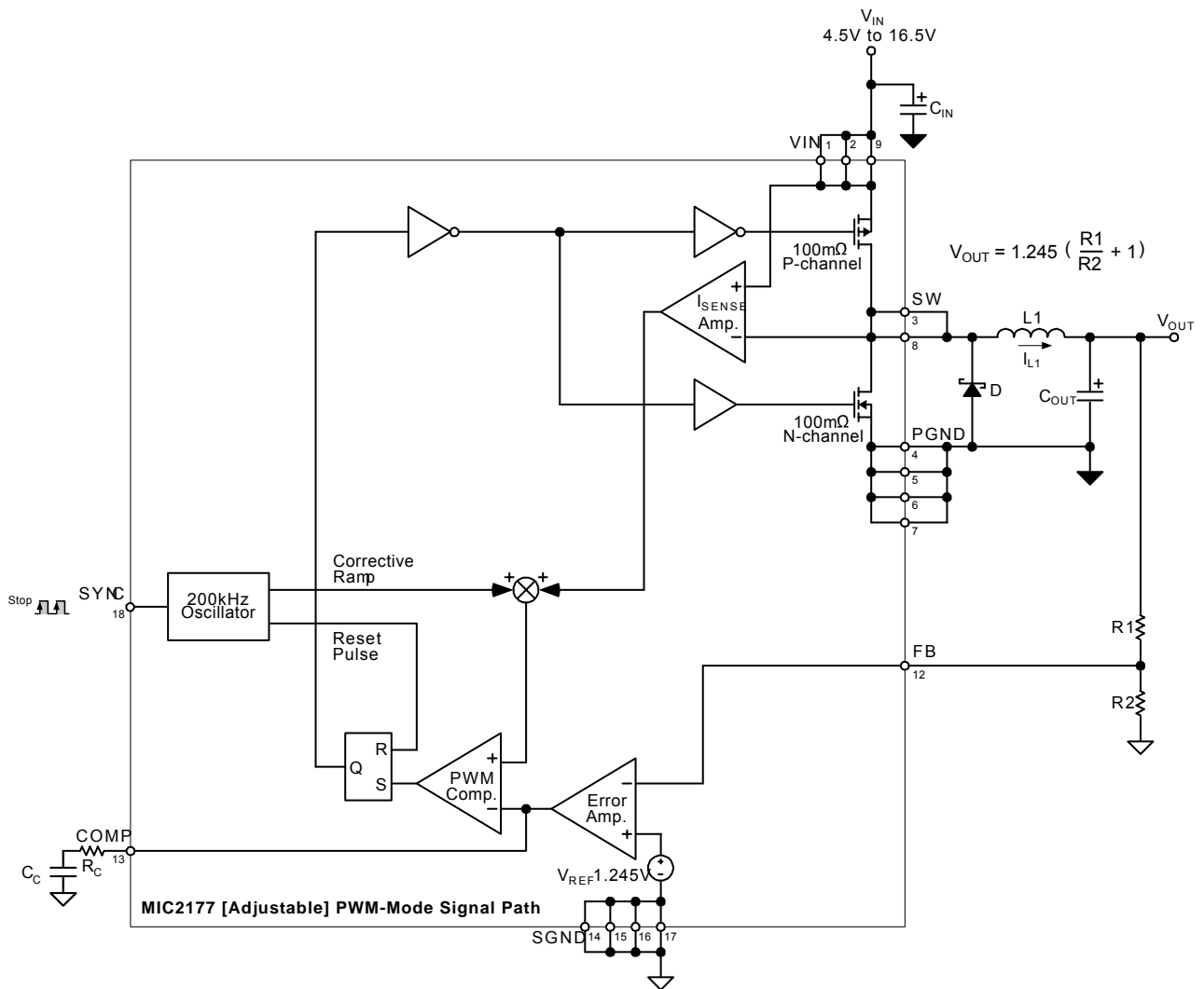

# Skip-Mode Functional Diagram

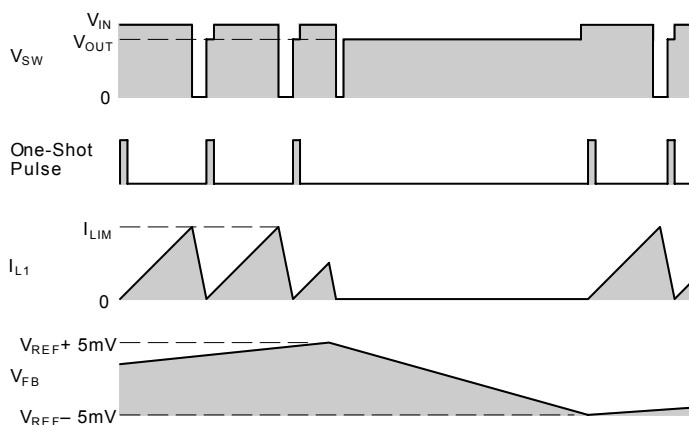
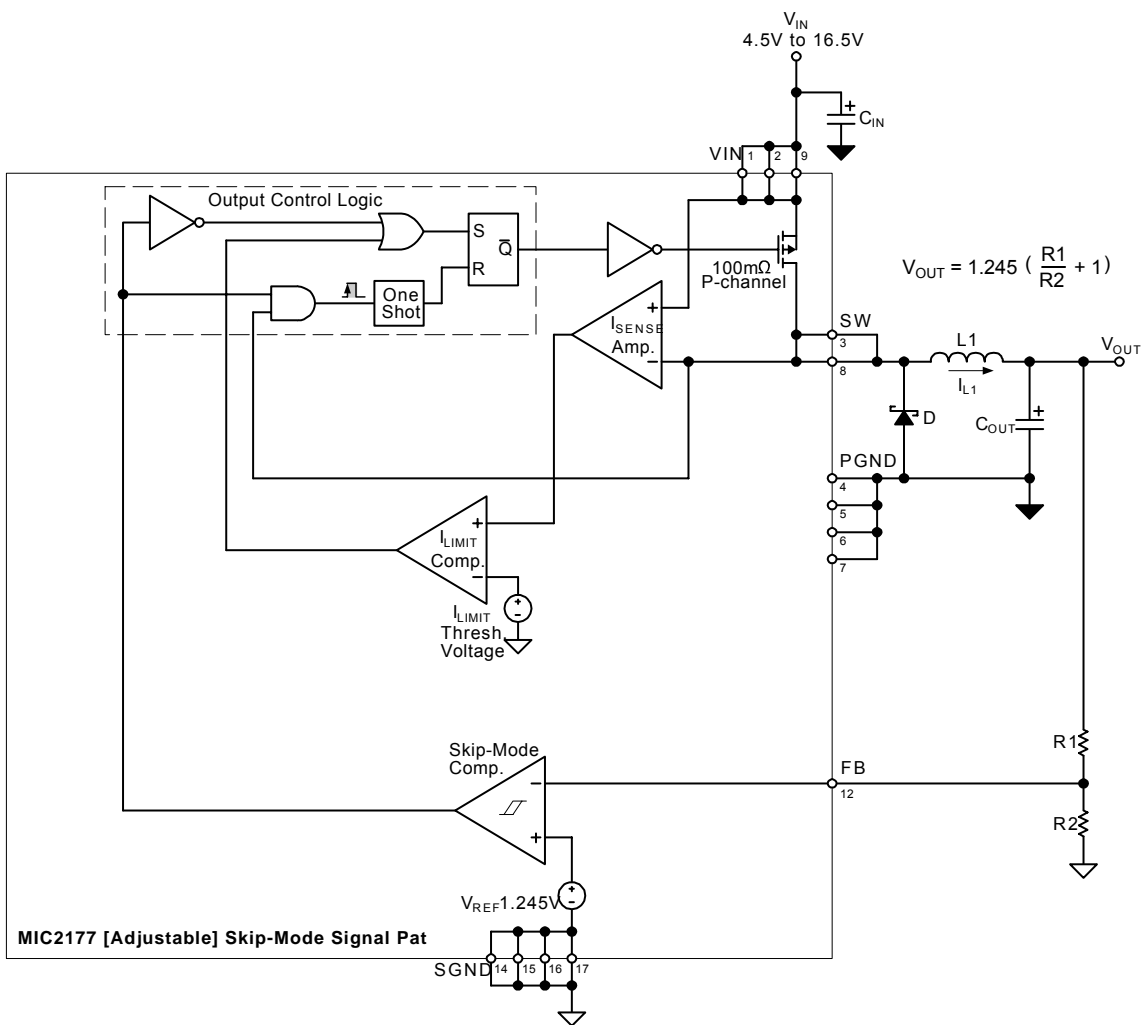

## Application Information

### Feedback Resistor Selection (Adjustable Version)

The output voltage is configured by connecting an external resistive divider to the FB pin as shown in "MIC2177 Block Diagram." The ratio of R1 to R2 determines the output voltage. To optimize efficiency during low output current operation, R2 should not be less than 20kΩ. However, to prevent feedback error due to input bias current at the FB pin, R2 should not be greater than 100kΩ. After selecting R2, calculate R1 using the following formula:

$$R1 = R2 \left[ \left( \frac{V_{OUT}}{1.245V} \right) - 1 \right]$$

### Input Capacitor Selection

The input capacitor is selected for its RMS current and voltage rating and should be a low ESR (equivalent series resistance) electrolytic or tantalum capacitor. As a rule-of-thumb, the voltage rating for a tantalum capacitor should be twice the value of  $V_{IN}$ , and the voltage rating for an electrolytic should be 40% higher than  $V_{IN}$ . The RMS current rating must be equal or greater than the maximum RMS input ripple current. A simple, worst-case formula for calculating this RMS current is:

$$I_{RMS(max)} = \frac{I_{LOAD(max)}}{2}$$

Tantalum capacitors are a better choice for applications that require the most compact layout or operation below 0°C. The input capacitor must be located very close to the  $V_{IN}$  pin (within 0.2 inches, 5mm). Also place a 0.1μF ceramic bypass capacitor as close as possible to  $V_{IN}$ .

### Inductor Selection

The inductor must be at least a minimum value in order for the MIC2177 to change from PWM to skip mode at the correct value of output current. This minimum value ensures the inductor ripple current never exceeds 600mA, and is calculated using the following formula:

$$L_{MIN} = V_{OUT} \left( 1 - \frac{V_{OUT}}{V_{IN(max)}} \right) \times 8.3\mu.3\mu$$

Where:

$$V_{IN(max)} = \text{maximum input voltage}$$

In general, a value at least 20% greater than  $L_{MIN}$  should be selected because inductor values have a tolerance of ±20%.

Two other parameters to consider in selecting an inductor are winding resistance and peak current rating. The inductor must have a peak current rating equal or greater than the peak inductor current. Otherwise, the inductor may saturate, causing excessive current in the output switch. Also, the inductor's core loss may

increase significantly. Both of these effects will degrade efficiency. The formula for peak inductor current is:

$$I_{L(peak)} = I_{LOAD(max)} + 300mA$$

To maximize efficiency, the inductor's resistance must be less than the output switch on-resistance (preferably 50mΩ or less).

### Output Capacitor Selection

Select an output capacitor that has a low value of ESR. This parameter determines a regulator's output ripple voltage ( $V_{RIPPLE}$ ) which is generated by  $\Delta I_L \times ESR$ . As mentioned in "Inductor Selection," the maximum value for  $\Delta I_L$  is 600mA.

Therefore, the maximum value of ESR is:

$$ESR_{MAX} = \frac{600mA}{V_{RIPPLE}}$$

Where:

$$V_{RIPPLE} < 1\% \text{ of } V_{OUT}$$

Typically, capacitors in the range of 100μF to 220μF have ESR less than this maximum value. The output capacitor can be either a low ESR electrolytic or tantalum capacitor, but tantalum is a better choice for compact layout and operation at temperatures below 0°C. The voltage rating of a tantalum capacitor must be  $2 \times V_{OUT}$ , and the voltage rating of an electrolytic must be  $1.4 \times V_{OUT}$ .

### Output Diode Selection

In PWM operation, inductor current flows through the output diode approximately 50ns during the dead time when one output MOSFET turns off and the other turns on. In skip-mode, the inductor current flows through the diode during the entire P-channel off time. The correct diode for both of these conditions is a 1A diode with a reverse voltage rating greater than  $V_{IN}$ . It must be a Schottky or ultra fast-recovery diode ( $t_R < 100ns$ ) to minimize power dissipation from the diode's reverse-recovery charge.

### Compensation

Compensation is provided by connecting a series RC load to the COMP pin. This creates a pole-zero pair in the regulator control loop, allowing the regulator to remain stable with enough low frequency loop-gain for good load and line regulation. At higher frequencies pole-zero reduces loop-gain to a level referred to as the mid-band gain. The mid-band gain is low enough so that the loop gain crosses 0dB with sufficient phase margin. Typical values for the RC load are 4.7nF – 10nF for the capacitor and 5kΩ – 20kΩ for the resistor.

### Printed Circuit Board Layout

A well designed PC board will prevent switching noise and ground bounce from interfering with the operation of

the MIC2177. A good design takes into consideration component placement and routing of power traces.

The first thing to consider is the locations of the input capacitor, inductor, output diode, and output capacitor. The input capacitor must be placed very close to the  $V_{IN}$  pin, the inductor and output diode very close to the SW pin, and the output capacitor near the inductor. These components pass large high-frequency current pulses, so they must use short, wide power traces. In addition, their ground pins and PGND are connected to a ground plane that is nearest the power supply ground bus.

The feedback resistors, RC compensation network, and BIAS pin bypass capacitor should be located near their respective pins. To prevent ground bounce, their ground traces and SGND should not be in the path of switching currents returning to the power supply ground bus. SGND and PGND should be tied together by a ground plane that extends under the MIC2177.

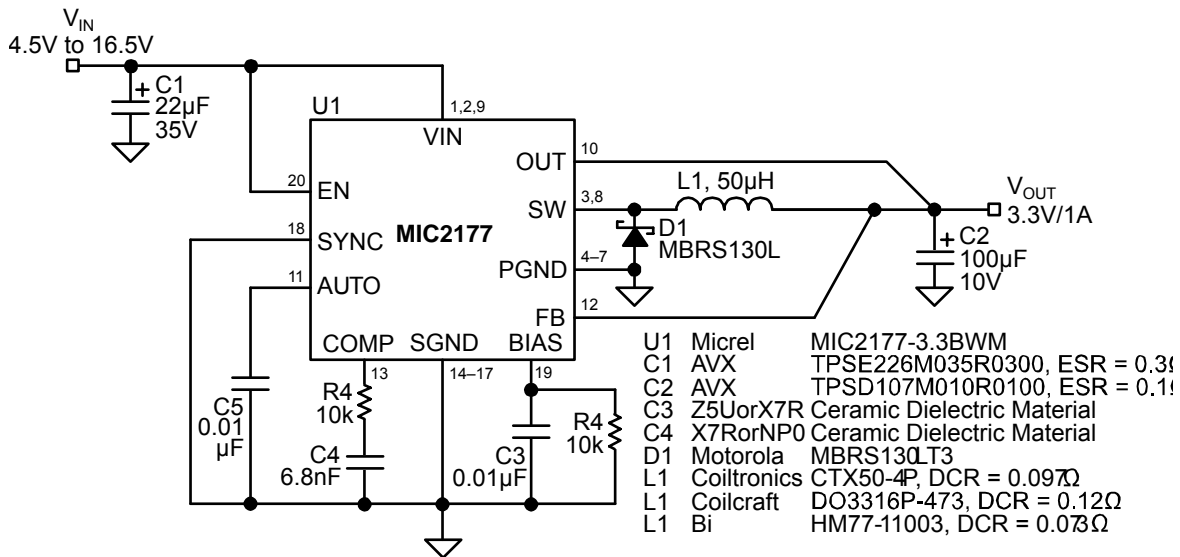

## Bill of Materials

Inductors	Capacitors	Diodes	Transistors
<b>Coilcraft</b> 1102 Silver Lake Rd. Cary, IL 60013 Tel: (708) 639-2361 Fax: (708) 639-1469	<b>AVX</b> 801 17 <sup>th</sup> Ave. Myrtle Beach, SC 29577 Tel: (803) 448-9411 Fax: (803) 448-1973	<b>General Instruments (GI)</b> 10 Melville Park Rd. Melville, NY 11747 Tel: (516) 847-3222 Fax: (516) 847-3150	<b>Siliconix</b> 2201 Laurelwood Rd. Santa Clara, CA 96056 Tel: (800) 554-5565
<b>Coiltronics</b> 6000 Park of Commerce Blvd. Boca Raton, FL 33487 Tel: (407) 241-7876 Fax: (407) 241-9339	<b>Sanyo Video Components Corp.</b> 2001 Sanyo Ave. San Diego, CA 92173 Tel: (619) 661-6835 Fax: (619) 661-1055	<b>International Rectifier Corp.</b> 233 Kansas St. El Segundo, CA 90245 Tel: (310) 322-3331 Fax: (310) 322-3332	
<b>Bi Technologies</b> 4200 Bonita Place Fullerton, CA 92835 Tel: (714) 447-2345 Fax: (714) 447-2500	<b>Sprague Electric</b> 60005 Lower Main St. Sanford, ME 04073 Tel: (207) 324-4140	<b>Motorola, Inc.</b> MS 56-126 3102 North 56 <sup>th</sup> St. Phoenix, AZ 85018 Tel: (602) 244-3576 Fax: (602) 244-4015	

# Package Information

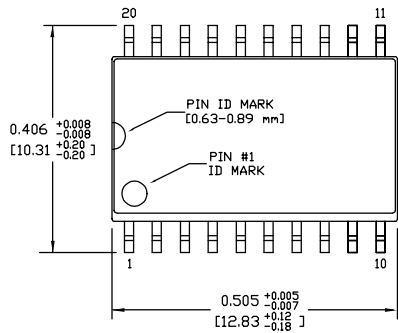

TOP VIEW

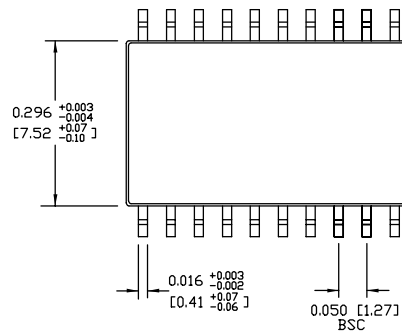

BOTTOM VIEW

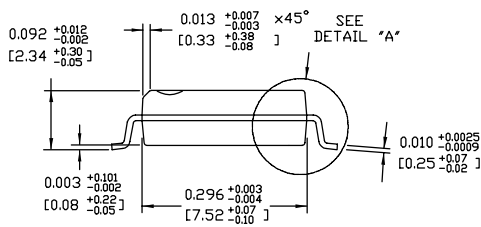

END VIEW

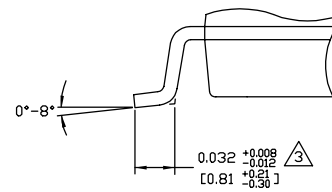

DETAIL "A"

**NOTES:**

1. DIMENSIONS ARE IN INCHES[MM].
2. CONTROLLING DIMENSION: INCHES.
3. DIMENSION DOES NOT INCLUDE MOLD FLASH OR PROTRUSIONS, EITHER OF WHICH SHALL NOT EXCEED 0.006[0.15] PER SIDE.

**20-Pin Wide SOIC (WM)**

**MICREL, INC. 2180 FORTUNE DRIVE SAN JOSE, CA 95131 USA**  
 TEL +1 (408) 944-0800 FAX +1 (408) 474-1000 WEB <http://www.micrel.com>

The information furnished by Micrel in this data sheet is believed to be accurate and reliable. However, no responsibility is assumed by Micrel for its use. Micrel reserves the right to change circuitry and specifications at any time without notification to the customer.

Micrel Products are not designed or authorized for use as components in life support appliances, devices or systems where malfunction of a product can reasonably be expected to result in personal injury. Life support devices or systems are devices or systems that (a) are intended for surgical implant into the body or (b) support or sustain life, and whose failure to perform can be reasonably expected to result in a significant injury to the user. A Purchaser's use or sale of Micrel Products for use in life support appliances, devices or systems is a Purchaser's own risk and Purchaser agrees to fully indemnify Micrel for any damages resulting from such use or sale.

© 1999 Micrel, Incorporated.



Компания «ЭлектроПласт» предлагает заключение долгосрочных отношений при поставках импортных электронных компонентов на взаимовыгодных условиях!

Наши преимущества:

- Оперативные поставки широкого спектра электронных компонентов отечественного и импортного производства напрямую от производителей и с крупнейших мировых складов;
- Поставка более 17-ти миллионов наименований электронных компонентов;
- Поставка сложных, дефицитных, либо снятых с производства позиций;
- Оперативные сроки поставки под заказ (от 5 рабочих дней);
- Экспресс доставка в любую точку России;
- Техническая поддержка проекта, помощь в подборе аналогов, поставка прототипов;
- Система менеджмента качества сертифицирована по Международному стандарту ISO 9001;
- Лицензия ФСБ на осуществление работ с использованием сведений, составляющих государственную тайну;
- Поставка специализированных компонентов (Xilinx, Altera, Analog Devices, Intersil, Interpoint, Microsemi, Aeroflex, Peregrine, Syfer, Eurofarad, Texas Instrument, Miteq, Cobham, E2V, MA-COM, Hittite, Mini-Circuits, General Dynamics и др.);

Помимо этого, одним из направлений компании «ЭлектроПласт» является направление «Источники питания». Мы предлагаем Вам помощь Конструкторского отдела:

- Подбор оптимального решения, техническое обоснование при выборе компонента;
- Подбор аналогов;
- Консультации по применению компонента;
- Поставка образцов и прототипов;
- Техническая поддержка проекта;
- Защита от снятия компонента с производства.



#### Как с нами связаться

**Телефон:** 8 (812) 309 58 32 (многоканальный)

**Факс:** 8 (812) 320-02-42

**Электронная почта:** [org@eplast1.ru](mailto:org@eplast1.ru)

**Адрес:** 198099, г. Санкт-Петербург, ул. Калинина, дом 2, корпус 4, литера А.