

Type HZC -55 °C to +125 °C

SMT Hybrid Polymer-Aluminum Electrolytic Capacitors

For filtering, Bypassing and Power Supply Decoupling with Long Life Requirements

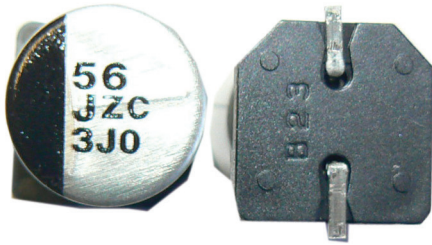

Type HZC hybrid capacitors are a combination of solid polymer aluminum technology with wet aluminum electrolytic technology. This results in a surface mount capacitor with a 4,000 hour life, low leakage current, high voltage capability, very low esr and small case sizes. They are ideal for high temperature and high reliability PC board designs. The vertical cylindrical cases facilitate automatic mounting and feature high reflow soldering temperature capability. Type HZC is RoHS compliant.

Highlights

- +125 °C, Up to 4,000 Hours Load Life
- Low Leakage Current
- Very Low ESR and High Ripple Current
- 260 °C reflow soldering

Specifications

Capacitance Range	10 to 330 μ F										
Capacitance Tolerance	$\pm 20\%$ @ 120 Hz/+20 °C										
Rated Voltage	25, 35, 50, 63 Vdc										
Leakage Current (at 20°C)	$I = .01CV$ or 3 μ A max., whichever is greater after 2 minutes I = leakage current in μ Amps C = rated capacitance in μ F V = rated DC Working voltage in Volts										
Low Temperature Characteristics (at 120 Hz)	Z(-25 °C)/Z(+20 °C): 2 Z(-55 °C)/Z(+20 °C): 2.5										
Ripple Current Frequency Multiplier	<table border="1"> <tr> <th>Frequency</th> <th>120 Hz</th> <th>1000 Hz</th> <th>10,000 Hz</th> <th>100 KHz</th> </tr> <tr> <th>Correction Factor</th> <td>0.1</td> <td>0.3</td> <td>0.6</td> <td>1</td> </tr> </table>	Frequency	120 Hz	1000 Hz	10,000 Hz	100 KHz	Correction Factor	0.1	0.3	0.6	1
Frequency	120 Hz	1000 Hz	10,000 Hz	100 KHz							
Correction Factor	0.1	0.3	0.6	1							
RoHS Compliant											

Outline Drawing

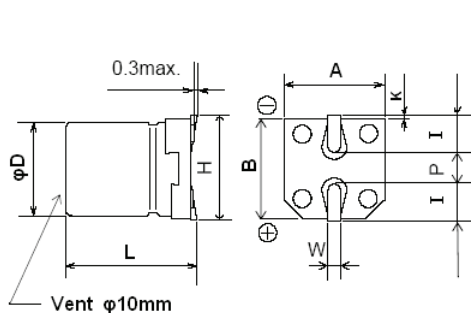

Case Code	D (± 0.5)	L (± 0.3)	A (± 0.2)	B (± 0.2)	H (max.)	I (ref.)	W	P (ref.)	K
C	5.0	5.8	5.3	5.3	6.5	2.2	0.65 ± 0.1	1.5	$0.35^{+0.15/-0.20}$
D	6.3	5.8	6.6	6.6	7.8	2.6	0.65 ± 0.1	1.8	$0.35^{+0.15/-0.20}$
X	6.3	7.7	6.6	6.6	7.8	2.6	0.65 ± 0.1	1.8	$0.35^{+0.15/-0.20}$
F	8.0	10.2	8.3	8.3	10.0	3.4	0.90 ± 0.2	3.1	0.70 ± 0.2
G	10.0	10.2	10.3	10.3	12.0	3.5	0.90 ± 0.2	4.6	0.70 ± 0.2

Capacitor Markings

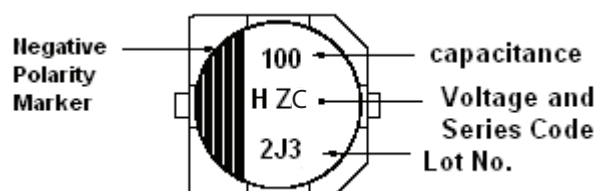

Voltage Code	Voltage Vdc
E	25
V	35
H	50
J	63

Lot, Number: Year, Line, Month

Type HZC -55 °C to +125 °C

SMT Hybrid Polymer-Aluminum Electrolytic Capacitors

Part Numbering System

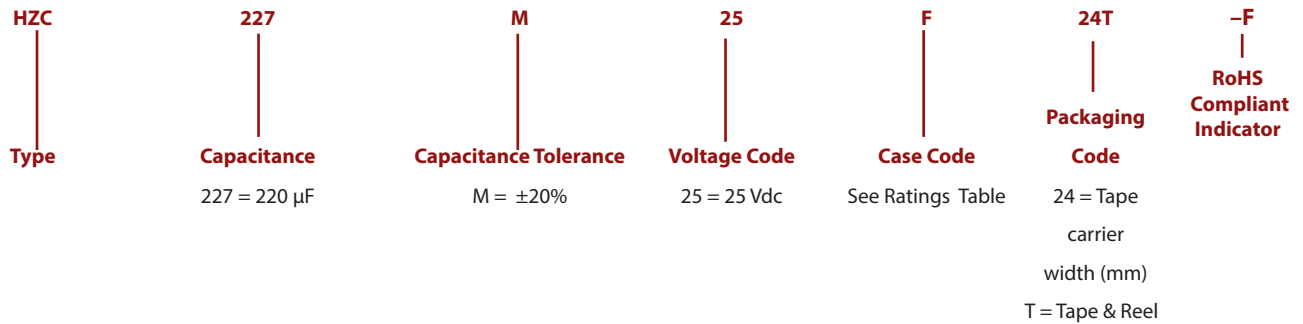

Ratings

Capacitance (µF)	Voltage Rating (Vdc)	CDE Part Number	MAX DCL (µA)	MAX DF @ 120 Hz/20°C	MAX E.S.R. @ 100kHz/+20°C (ohms)	MAX Ripple Current @ 100kHz/+125°C (A rms)	D (mm)	L (mm)	Case Code	QTY/reel
25 Vdc (32 Vdc Surge)										
33	25	HZC336M025C12T-F	8.2	0.14	0.080	0.55	5.0	5.8	C	1000
56	25	HZC566M025D16T-F	14.0	0.14	0.050	0.90	6.3	5.8	D	1000
100	25	HZC107M025X16T-F	25.0	0.14	0.030	1.40	6.3	7.7	X	900
220	25	HZC227M025F24T-F	55.0	0.14	0.027	1.60	8.0	10.2	F	500
330	25	HZC337M025G24T-F	82.5	0.14	0.020	2.00	10.0	10.2	G	500
35 Vdc (44 Vdc Surge)										
22	35	HZC226M035C12T-F	7.7	0.12	0.100	0.55	5.0	5.8	C	1000
47	35	HZC476M035D16T-F	16.4	0.12	0.060	0.90	6.3	5.8	D	1000
68	35	HZC686M035X16T-F	23.8	0.12	0.035	1.40	6.3	7.7	X	900
150	35	HZC157M035F24T-F	52.5	0.12	0.027	1.60	8.0	10.2	F	500
270	35	HZC277M035G24T-F	94.5	0.12	0.020	2.00	10.0	10.2	G	500
50 Vdc (63 Vdc Surge)										
10	50	HZC106M050C12T-F	5.0	0.10	0.120	0.50	5.0	5.8	C	1000
22	50	HZC226M050D16T-F	11.0	0.10	0.080	0.75	6.3	5.8	D	1000
33	50	HZC336M050X16T-F	16.5	0.10	0.040	1.10	6.3	7.7	X	900
68	50	HZC686M050F24T-F	34.0	0.10	0.030	1.25	8.0	10.2	F	500
100	50	HZC107M050G24T-F	50.0	0.10	0.028	1.60	10.0	10.2	G	500
63 Vdc (79 Vdc Surge)										
10	63	HZC106M063D16T-F	6.3	0.08	0.120	0.70	6.3	5.8	D	1000
22	63	HZC226M063X16T-F	13.8	0.08	0.080	0.90	6.3	7.7	X	900
33	63	HZC336M063F24T-F	20.7	0.08	0.040	1.10	8.0	10.2	F	500
56	63	HZC566M063G24T-F	35.2	0.08	0.030	1.40	10.0	10.2	G	500

Type HZC -55 °C to +125 °C

SMT Hybrid Polymer-Aluminum Electrolytic Capacitors

Load Life Test

Test	Apply the maximum rated voltage for 4,000 hrs at +125 °C with full rated ripple current. After the test measure the capacitance, DF, DCL and ESR at +20 °C. Also measure the ESR at -40 °C and 100kHz.
ΔC at 120Hz	Capacitance will be within ±30% of the initial measured value
DF at 120 Hz	DF will be ≤ 200% of the initial specified value
DCL after 2 minute charge	Leakage current will be ≤ the initial specified value
ESR at 100kHz/+20 °C	ESR will be ≤ 200% of the initial specified value
Max. ESR at 100kHz/-40 °C after Load Life test	Case Code C : 2.0 Ω; Case Code D : 1.4 Ω; Case Code X : 0.8 Ω; Case Code F : 0.4 Ω; Case Code G : 0.3 Ω

Shelf Life Test

Test	Subject the capacitor to 1000 hrs at +125 °C without voltage. After the test, return the capacitor to room temperature for two hours and then apply rated voltage for 30 minutes. The after test measurements for capacitance, DF, DCL and ESR at +20 °C will meet the following.
ΔC at 120 Hz	Capacitance will be within ±30% of the initial measured value
DF at 120 Hz	DF will be ≤ 200% of the initial specified value
DCL after 2 minute charge	Leakage current will be ≤ the initial specified value
ESR at 100Khz/+20 °C	ESR will be ≤ 200% of the initial specified value

Moisture Resistance Test

Test	Subject the capacitor to 2000 hrs at +85 °C/85%RH with rated voltage. After the test, return the capacitor to room temperature and humidity for two hours. The after test measurements for capacitance, DF, DCL and ESR at +20 °C will meet the following.
ΔC at 120 Hz	Capacitance will be within ±30% of the initial measured value
DF at 120 Hz	DF will be ≤ 200% of the initial specified value
DCL after 2 minute charge	Leakage current will be ≤ the initial specified value
ESR at 100Khz/+20 °C	ESR will be ≤ 200% of the initial specified value

Temperature Cycle Test

Test	Subject the capacitor to 1000 cycles of temperature change from -55 °C to +125 °C using the following sequence and durations.		
	Step	Temperature	Time at Temperature
	1	-55 °C	30 minutes
	2	+20 °C	3 minutes max
	3	+125 °C	30 minutes
4	+20 °C	3 minutes max	
	After the test, return the capacitor to +20°C for one to two hours before measurement. The after test measurements for capacitance, DF, and DCL at +20 °C will meet the following;		
ΔC at 120 Hz	Capacitance will be within ±20% of the initial measured value		
DF at 120 Hz	DF will be ≤ 200% of the initial specified value		
DCL after 2 minute charge	Leakage current will be ≤ the initial specified value		
Appearance	No significant change in appearance		

Type HZC -55 °C to +125 °C

SMT Hybrid Polymer-Aluminum Electrolytic Capacitors

Reel Dimensions

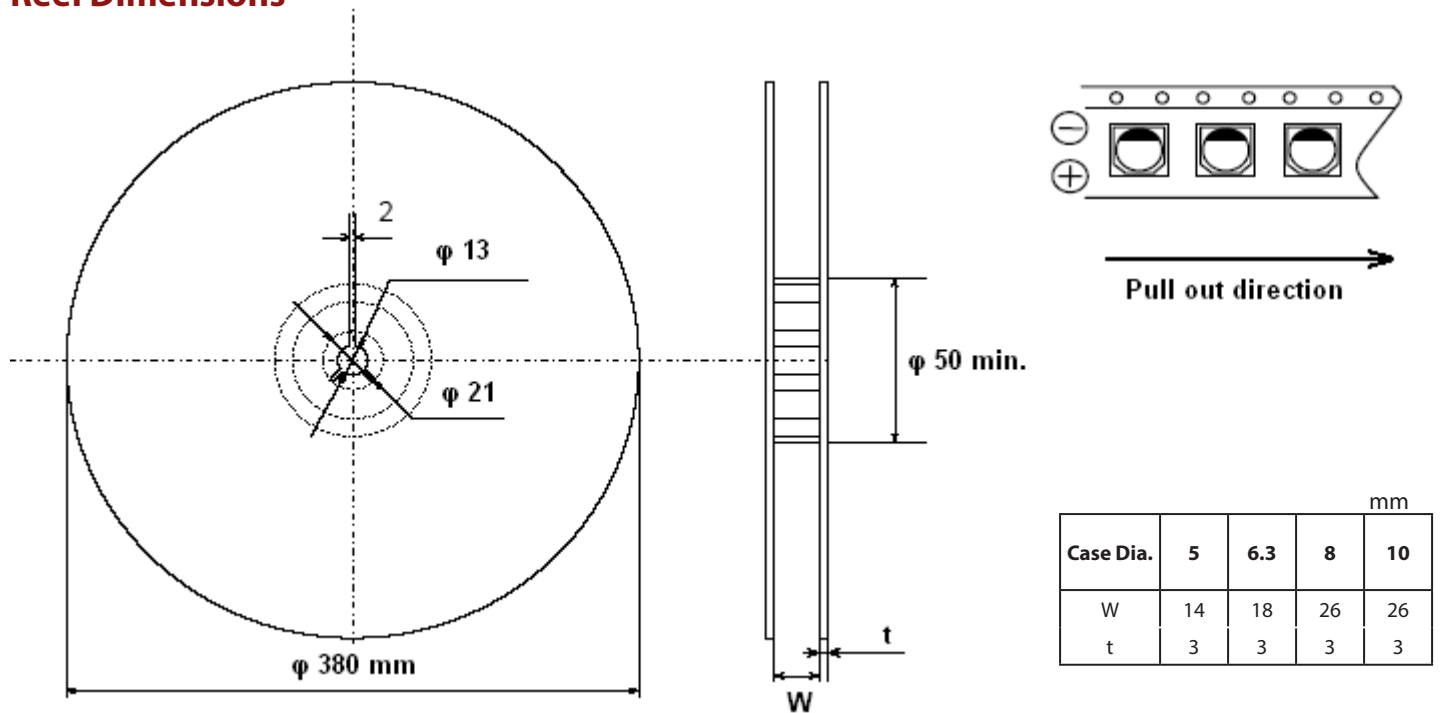

Tape Dimensions

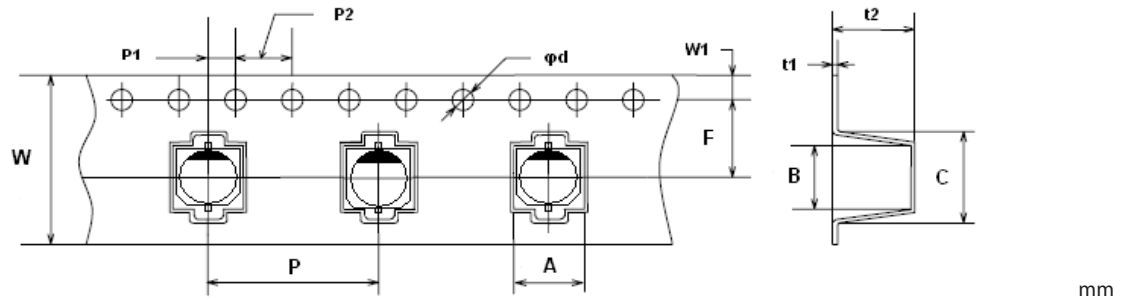

Case Size (mm)	Case Code	$W \pm 0.3$	$A \pm 0.2$	$B^{+0.3/-0.2}$	$C \pm 0.5$	$F \pm 0.1$	$P \pm 0.1$	t_1	$t_2 \pm 0.2$	$\phi d^{+0.1/-0}$	$P_1 \pm 0.1$	$P_2 \pm 0.1$	$W_1 \pm 0.1$
5 x 5.8	C	12	5.7	5.7	8.0	5.5	12	0.4	6.4	1.5	2	4	1.75

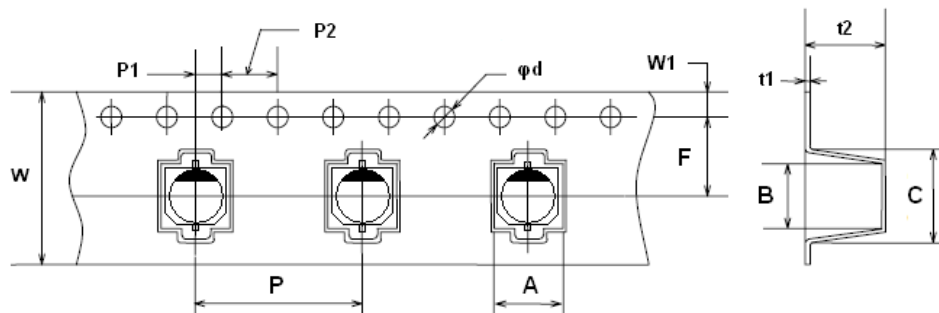

Case Size (mm)	Case Code	$W \pm 0.3$	$A \pm 0.2$	$B^{+0.3/-0.2}$	$C \pm 0.5$	$F \pm 0.1$	$P \pm 0.1$	t_1	$t_2 \pm 0.2$	$\phi d^{+0.1/-0}$	$P_1 \pm 0.1$	$P_2 \pm 0.1$	$W_1 \pm 0.1$
6.3 x 5.8	D	16	7	7	9.0	7.5	12	0.4	6.4	1.5	2	4	1.75
6.3 x 7.7	X								8.4				
8 x 10.2	F	24	8.7	8.7	12.5	11.5	16	0.4	11				
10 x 10.2	G		10.7	10.7	14.5								

Type HZC -55 °C to +125 °C

SMT Hybrid Polymer-Aluminum Electrolytic Capacitors

Recommended Land Dimensions

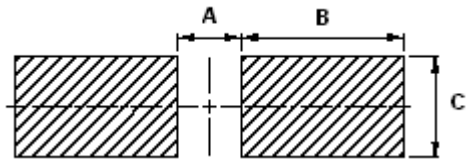

Case Code	D (mm)	A	B	C
C	5	1.5	2.8	1.6
D	6.3	1.8	3.2	1.6
X	6.3	1.8	3.2	1.6
F	8	3.1	4.0	2.0
G	10	4.6	4.1	2.0

Recommended Reflow Soldering

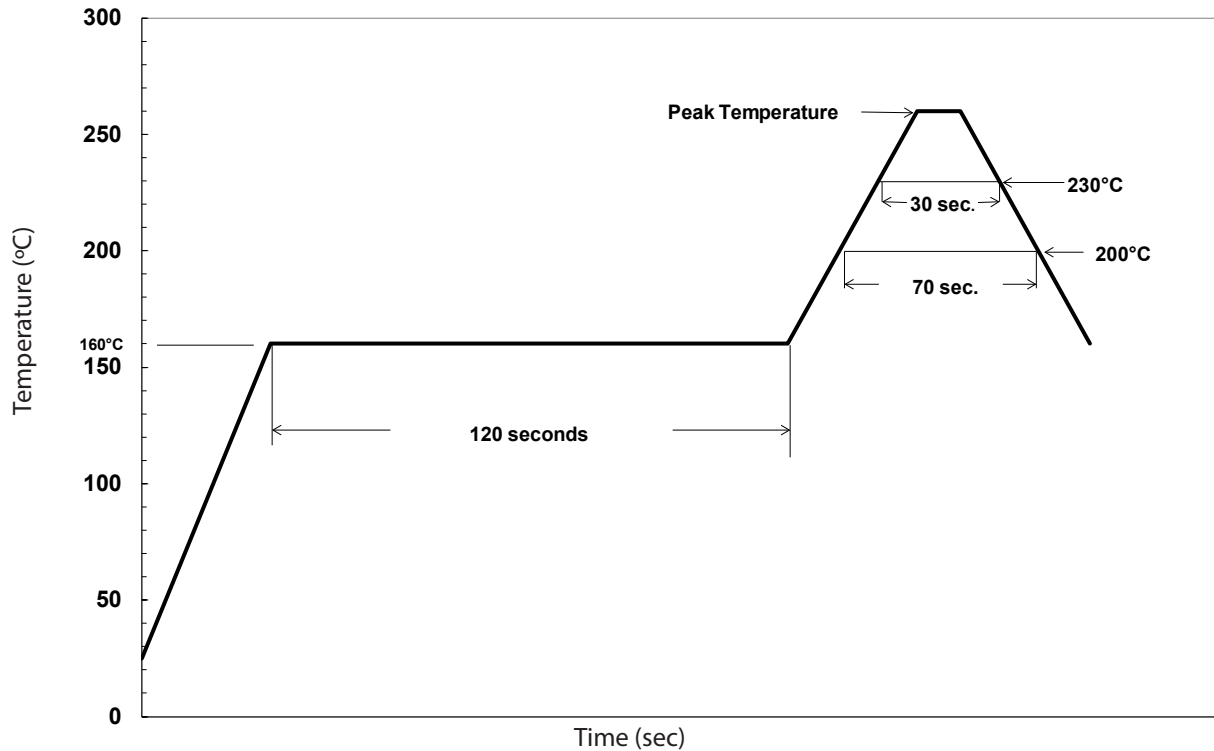

Case Code	Case Dia. (mm)	Peak Temperature	Time at or above 250 °C	Time at or above 230 °C	Time at or above 217 °C	Time at or above 200 °C	Number of Reflow Processes
C	5	260°C	5 seconds	30 seconds	40 seconds	70 seconds	2
D	6.3						
X	6.3						
F	8	260°C	5 seconds	30 seconds	40 seconds	70 seconds	1
G	10						

Notes:

- For 5mm and 6.3 mm case dia., if the peak temperature does not exceed 255 °C the time at or above 250 °C can increase to 10 seconds.
- The capacitors in the 8m and 10 mm case dia. can withstand 2 reflow processes, if the peak temperature does not exceed 245 °C and the time at or above 240 °C does not exceed 10 seconds.
- The 2nd reflow process should be performed after the capacitors have returned to room temperature.
- Temperature should be measured with a thermal couple placed on the top surface of the capacitor.
- After reflow soldering, the leakage current, D.F., and e.s.r., will meet the initial specifications, and the capacitance will be within $\pm 10\%$ of the initial measured value when measured at room conditions.

Type HZC -55 °C to +125 °C

SMT Hybrid Polymer-Aluminum Electrolytic Capacitors

Capacitor Temperature Characteristics 330 μ F/25V

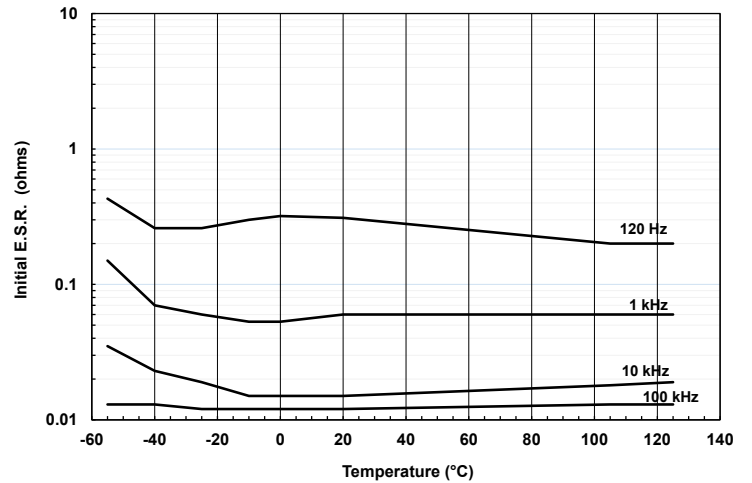
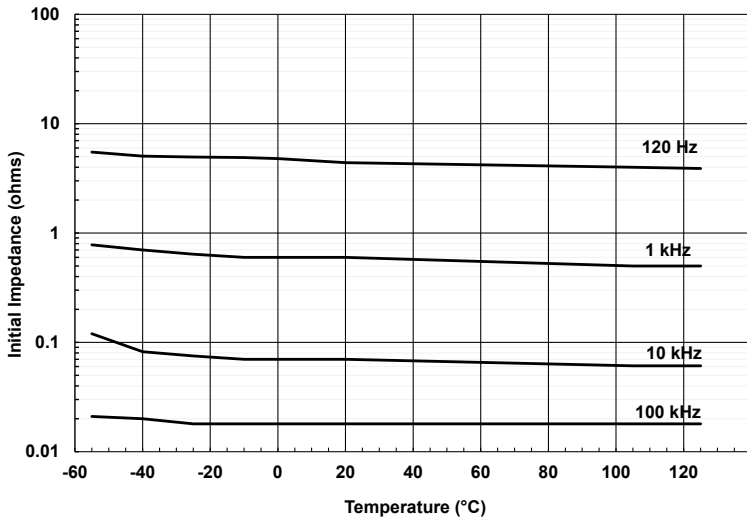
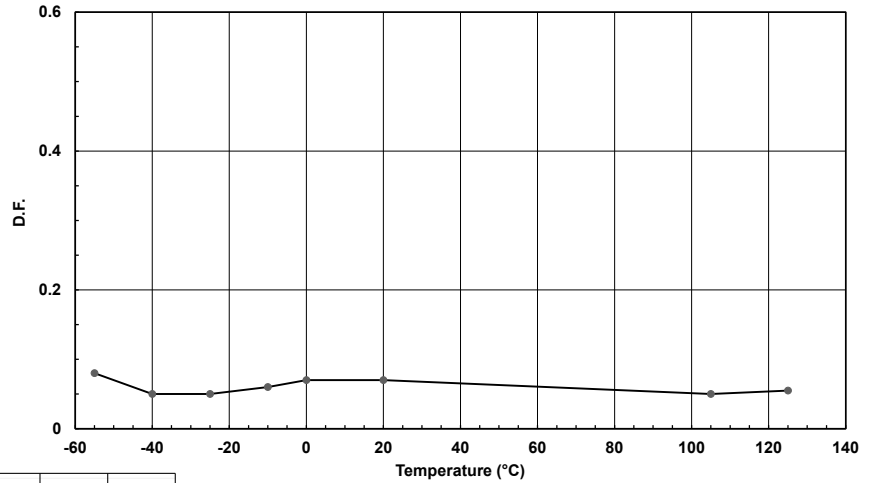
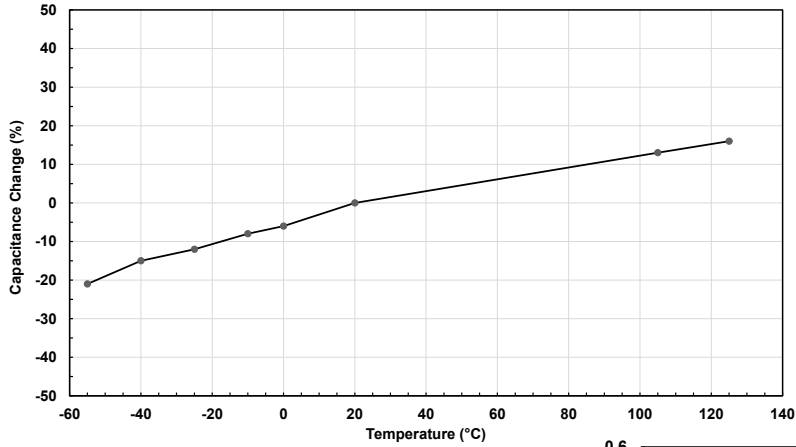

Type HZC -55 °C to +125 °C

SMT Hybrid Polymer-Aluminum Electrolytic Capacitors

Capacitor Temperature Characteristics

Life Test Results

330 μ F/25V at +125 °C with rated voltage

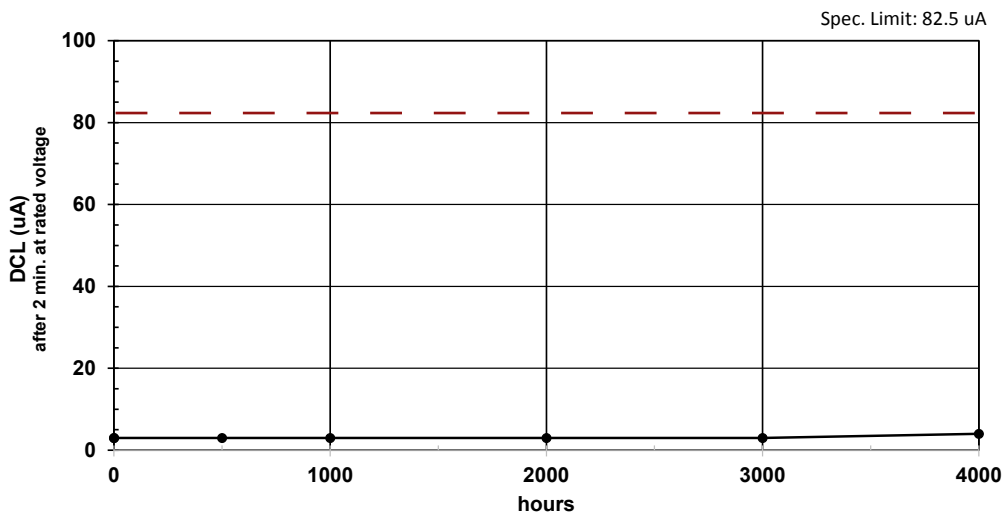
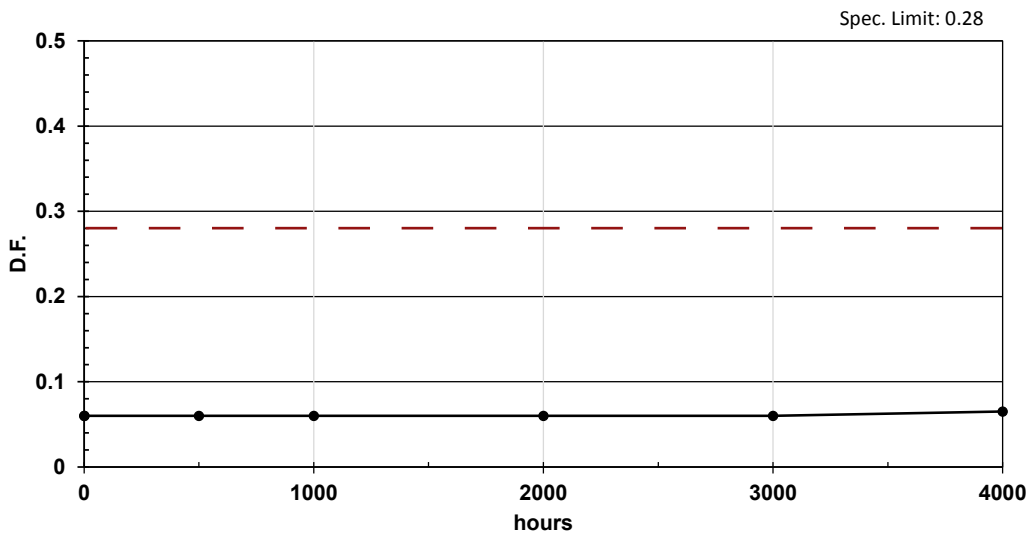
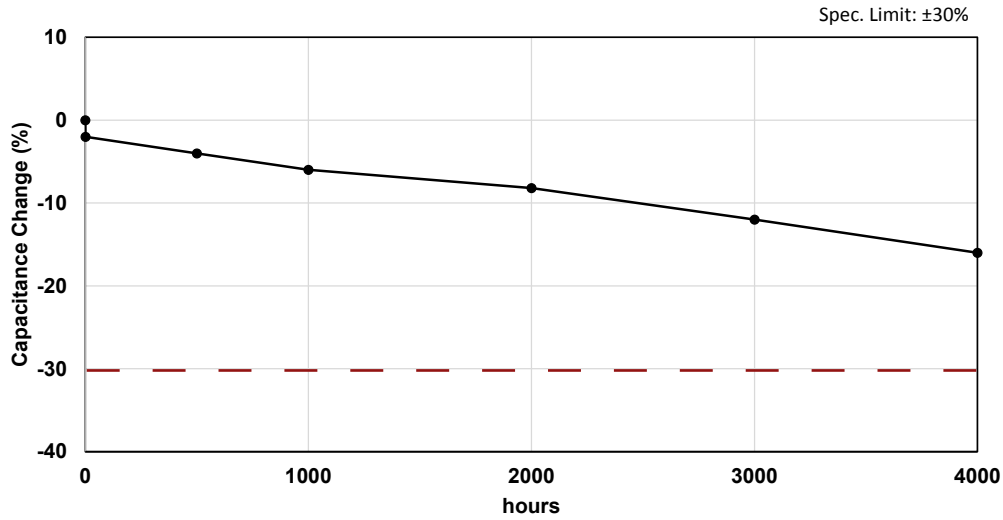

Notice and Disclaimer: All product drawings, descriptions, specifications, statements, information and data (collectively, the "Information") in this datasheet or other publication are subject to change. The customer is responsible for checking, confirming and verifying the extent to which the Information contained in this datasheet or other publication is applicable to an order at the time the order is placed. All Information given herein is believed to be accurate and reliable, but it is presented without any guarantee, warranty, representation or responsibility of any kind, expressed or implied. Statements of suitability for certain applications are based on the knowledge that the Cornell Dubilier company providing such statements ("Cornell Dubilier") has of operating conditions that such Cornell Dubilier company regards as typical for such applications, but are not intended to constitute any guarantee, warranty or representation regarding any such matter – and Cornell Dubilier specifically and expressly disclaims any guarantee, warranty or representation concerning the suitability for a specific customer application, use, storage, transportation, or operating environment. The Information is intended for use only by customers who have the requisite experience and capability to determine the correct products for their application. Any technical advice inferred from this Information or otherwise provided by Cornell Dubilier with reference to the use of any Cornell Dubilier products is given gratis (unless otherwise specified by Cornell Dubilier), and Cornell Dubilier assumes no obligation or liability for the advice given or results obtained. Although Cornell Dubilier strives to apply the most stringent quality and safety standards regarding the design and manufacturing of its products, in light of the current state of the art, isolated component failures may still occur. Accordingly, customer applications which require a high degree of reliability or safety should employ suitable designs or other safeguards (such as installation of protective circuitry or redundancies or other appropriate protective measures) in order to ensure that the failure of an electrical component does not result in a risk of personal injury or property damage. Although all product-related warnings, cautions and notes must be observed, the customer should not assume that all safety measures are indicated in such warnings, cautions and notes, or that other safety measures may not be required.



Компания «ЭлектроПласт» предлагает заключение долгосрочных отношений при поставках импортных электронных компонентов на взаимовыгодных условиях!

Наши преимущества:

- Оперативные поставки широкого спектра электронных компонентов отечественного и импортного производства напрямую от производителей и с крупнейших мировых складов;
- Поставка более 17-ти миллионов наименований электронных компонентов;
- Поставка сложных, дефицитных, либо снятых с производства позиций;
- Оперативные сроки поставки под заказ (от 5 рабочих дней);
- Экспресс доставка в любую точку России;
- Техническая поддержка проекта, помощь в подборе аналогов, поставка прототипов;
- Система менеджмента качества сертифицирована по Международному стандарту ISO 9001;
- Лицензия ФСБ на осуществление работ с использованием сведений, составляющих государственную тайну;
- Поставка специализированных компонентов (Xilinx, Altera, Analog Devices, Intersil, Interpoint, Microsemi, Aeroflex, Peregrine, Syfer, Eurofarad, Texas Instrument, Miteq, Cobham, E2V, MA-COM, Hittite, Mini-Circuits, General Dynamics и др.);

Помимо этого, одним из направлений компании «ЭлектроПласт» является направление «Источники питания». Мы предлагаем Вам помощь Конструкторского отдела:

- Подбор оптимального решения, техническое обоснование при выборе компонента;
- Подбор аналогов;
- Консультации по применению компонента;
- Поставка образцов и прототипов;
- Техническая поддержка проекта;
- Защита от снятия компонента с производства.



Как с нами связаться

Телефон: 8 (812) 309 58 32 (многоканальный)

Факс: 8 (812) 320-02-42

Электронная почта: org@eplast1.ru

Адрес: 198099, г. Санкт-Петербург, ул. Калинина, дом 2, корпус 4, литера А.