

TWO PHASE HALL-EFFECT SMART FAN MOTOR CONTROLLER

NEW PRODUCT

Description

The AH2985 is a single-chip solution for driving two-coil brushless direct current (BLDC) fans and motors. The device includes a Hall-effect sensor, dynamic offset correction and two complementary open-drain output drivers with internal Zener diode protection. It is optimized for low start-up voltage.

To help protect the motor coils, the AH2985 provides Rotor Lock Protection which shuts down output drives if rotor lock is detected. The device automatically re-starts when the rotor lock is removed. Over temperature shutdown provides thermal protection for the device.

The AH2985 is available in TO94 package.

Features

- Single-Chip Solution
- Operating Voltage: 2.5V to 15V
- Built-in Hall Sensor and Input Amplifier
- Rotor Lock Protection (Lock Detection, Output Shutdown and Automatic re-Start)
- Built-in Reverse Voltage Protection Diode
- Built-in Zener Protection for Output Drivers
- Average Output Current up to 500mA
- Package: TO94
- "Green" Molding Compound
- **Totally Lead-Free & Fully RoHS Compliant (Notes 1 & 2)**
- **Halogen and Antimony Free. "Green" Device (Note 3)**

- Notes:
1. No purposely added lead. Fully EU Directive 2002/95/EC (RoHS) & 2011/65/EU (RoHS 2) compliant.
 2. See http://www.diodes.com/quality/lead_free.html for more information about Diodes Incorporated's definitions of Halogen- and Antimony-free, "Green" and Lead-free.
 3. Halogen- and Antimony-free "Green" products are defined as those which contain <900ppm bromine, <900ppm chlorine (<1500ppm total Br + Cl) and <1000ppm antimony compounds.

Pin Assignments

(Top View)

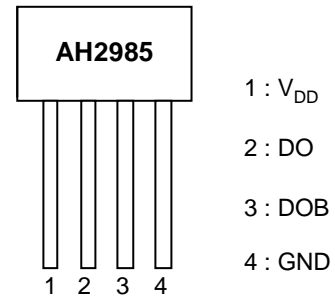

TO94

Applications

- Two-Coil BLDC Cooling Fans
- Low Voltage/ Low Power BLDC Motors

Typical Applications Circuit (Note 4)

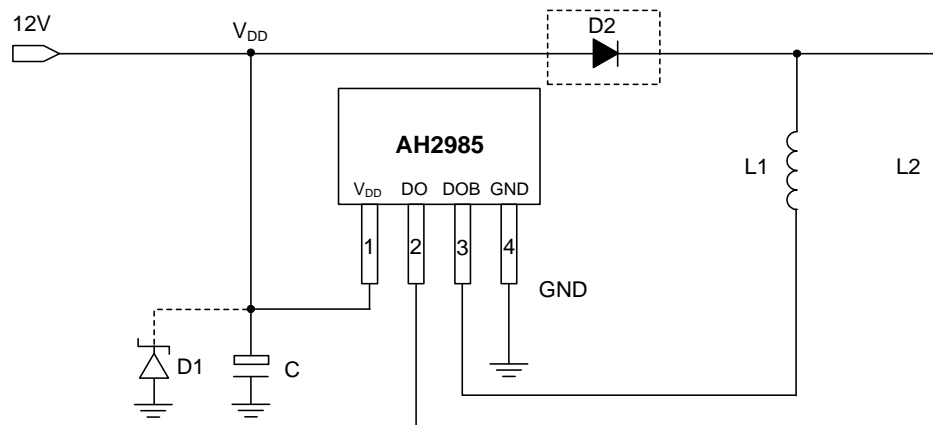

12V Brushless DC Fan

Note: 4. D1 (Zener Diode) and Capacitor C are for power stabilization. Recommended value of C is 1µF/ 50V (E-Cap). Diode D2 is optional and helps to protect the device and fan coils from reverse power conditions. The AH2985 also includes an internal reverse blocking diode at VDD pin.

Pin Descriptions

Pin Number	Pin Name	Function
1	V _{DD}	Input Power
2	DO	Output Pin
3	DOB	Output Pin
4	GND	Ground

Functional Block Diagram

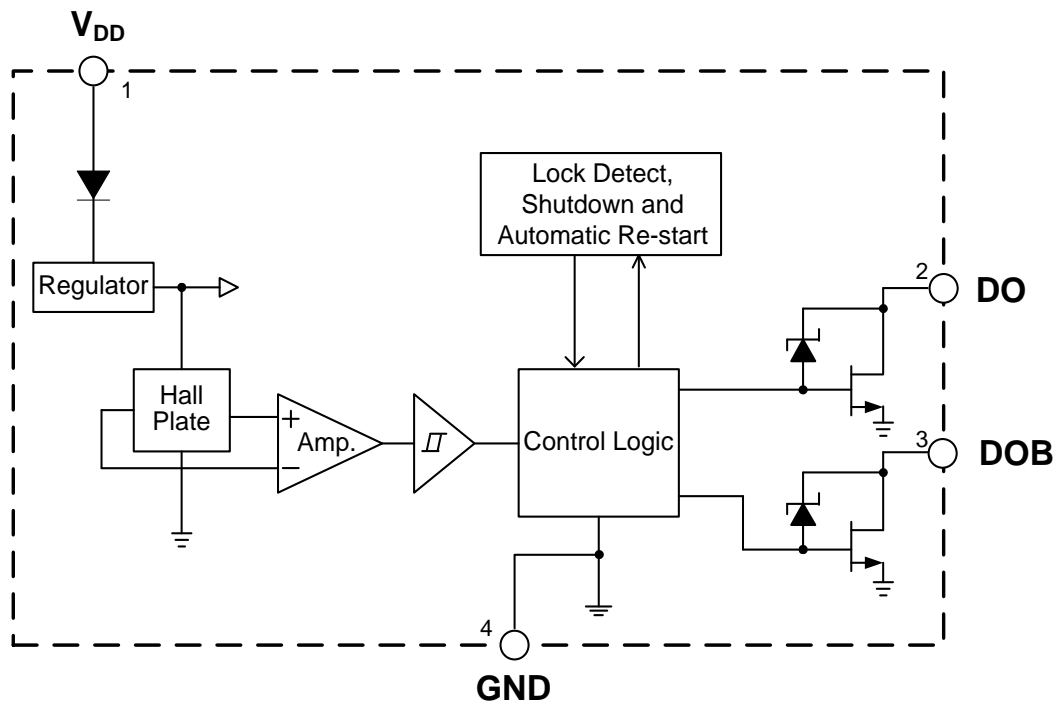

NEW PRODUCT

Absolute Maximum Ratings (@T_A = +25°C, unless otherwise specified.) (Note 5)

Symbol	Parameter	Rating	Unit
V _{DD}	Supply Voltage	18	V
V _{RDD}	Reverse V _{DD} Polarity Voltage	-15	V
I _{O(AVE)}	Output Current (Note 6)	500	mA
I _{O(peak as hold)}		800	
P _D	Power Dissipation	550	mW
T _{STG}	Storage Temperature	-55 to +150	°C
T _J	Maximum Junction Temperature	+150	°C
θ _{JA}	Thermal Resistance	227	°C/W
θ _{JC}	Thermal Resistance	49	°C/W

- Notes:
- Stresses greater than those listed under "Absolute Maximum Ratings" may cause permanent damage to the device. These are stress ratings only, and functional operation of the device at these or any other conditions beyond those indicated under "Recommended Operating Conditions" is not implied. Exposure to "Absolute Maximum Ratings" for extended periods may affect device reliability.
 - Shall not exceed P_D and Safety Operation Area.

Recommended Operating Conditions (@T_A = +25°C, unless otherwise specified.)

Symbol	Parameter	Condition	Min	Max	Unit
V _{DD}	Supply Voltage	Operating	2.5	15	V
T _A	Operating Ambient Temperature (Note 6)	Operating	-40	+105	°C

Electrical Characteristics (@T_A = +25°C, V_{DD} = 12V, unless otherwise specified.)

Symbol	Parameter	Condition	Min	Typ	Max	Unit
I _{DD}	Supply Current	Operating, V _{DD} = 12V	–	1	5	mA
t _{ON}	Locked Protection On Time	–	–	0.45	–	s
t _{OFF}	Locked Protection Off Time	–	–	2.7	–	s
R _{DUTY}	Locked Protection Duty Ratio	t _{OFF} / t _{ON}	–	6	–	–
R _{DS(ON)}	Output On Resistance	I _O = 300mA	–	1	1.6	Ω
		I _O = 500mA	–	1	1.8	
V _Z	Output Zener-Breakdown Voltage	(Note 7)	20	28	36	V

Note: 7. The V_Z value is in D.C. voltage measurement. The V_Z may vary with coils in A.C. voltage measurements.

Magnetic Characteristics ($T_A = +25^\circ\text{C}$, $V_{DD} = 2.5\text{V to }15\text{V}$, Note 8)

(1mT=10 Gauss)

Symbol	Parameter	Min	Typ	Max	Unit
B _{OP}	Operate Point	5	30	60	Gauss
B _{RP}	Release Point	-60	-30	-5	Gauss
B _{HY}	Hysteresis	20	60	120	Gauss

Note: 8. The magnetic characteristics may vary with supply voltage, operating temperature and after soldering.

Operating Characteristics

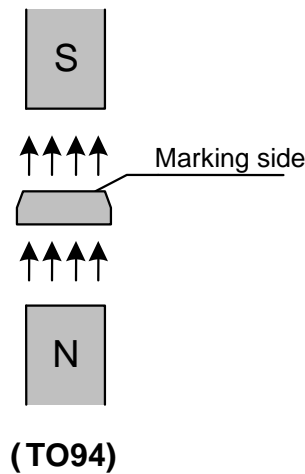
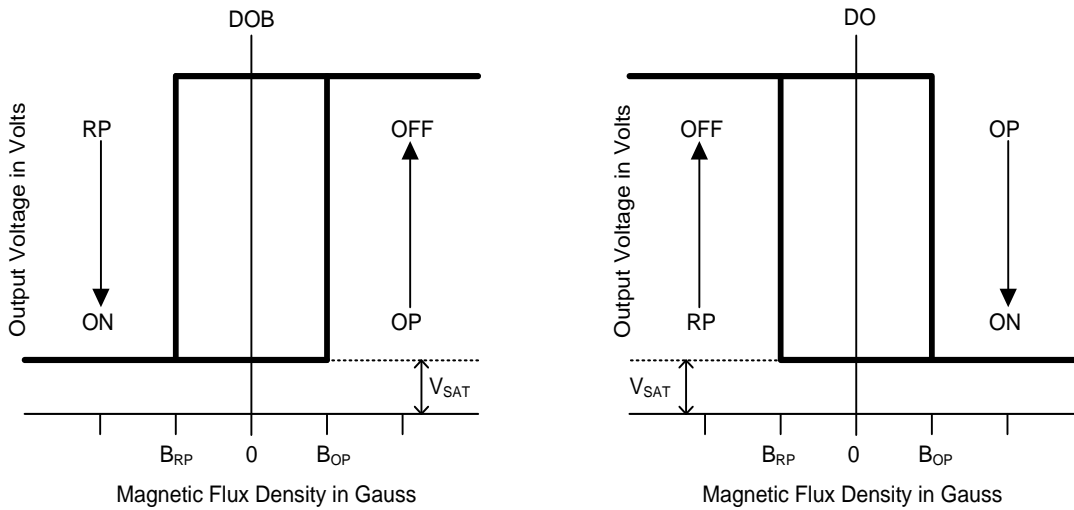

NEW PRODUCT

Performance Characteristics

(1) TO94

$T_A(^{\circ}\text{C})$	25	50	60	70	80	85	90	95	100
$P_D(\text{mW})$	550	440	396	352	308	286	264	242	220
$T_A(^{\circ}\text{C})$	105	110	115	120	125	130	135	140	150
$P_D(\text{mW})$	198	176	154	132	110	88	66	44	0

P_D (mW)

Power Dissipation Curve

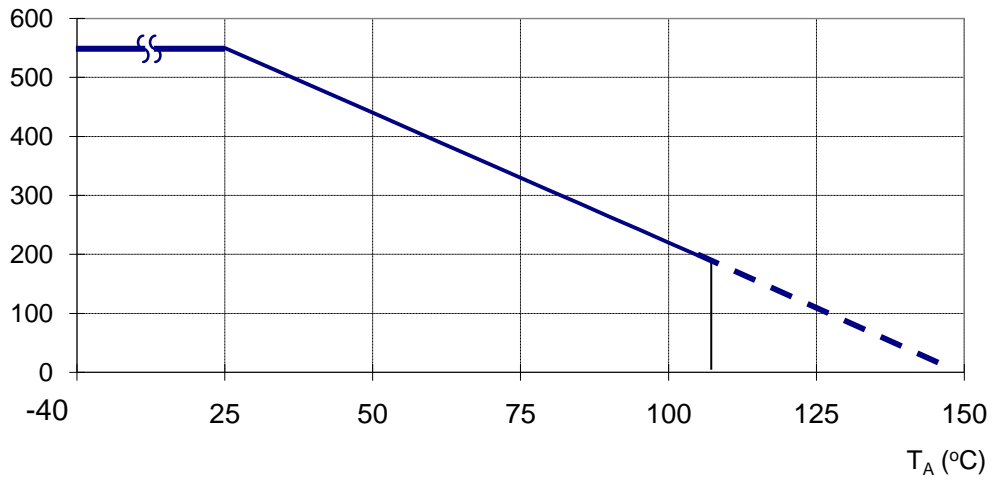

NEW PRODUCT

Ordering Information (Note 9)

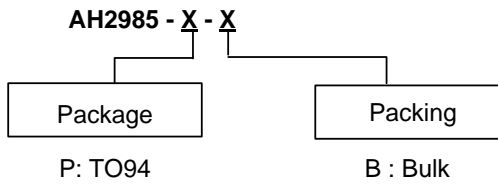

Part Number	Package Code	Packaging (Note 9)	Bulk	
			Quantity	Part Number Suffix
AH2985-P-B	P	TO94	1000	-B

Note: 9. For packaging details, go to our website at <http://www.diodes.com/products/packages.html>.

Marking Information

(1) TO94

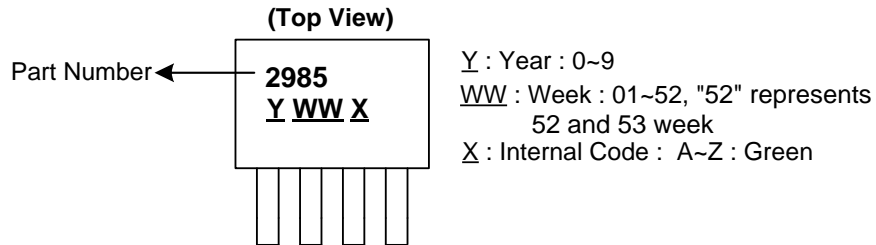

Package Outline Dimensions (All dimensions in mm.)

Please see AP02002 at <http://www.diodes.com/datasheets/ap02002.pdf> for the latest version.

(1) Package Type: TO94

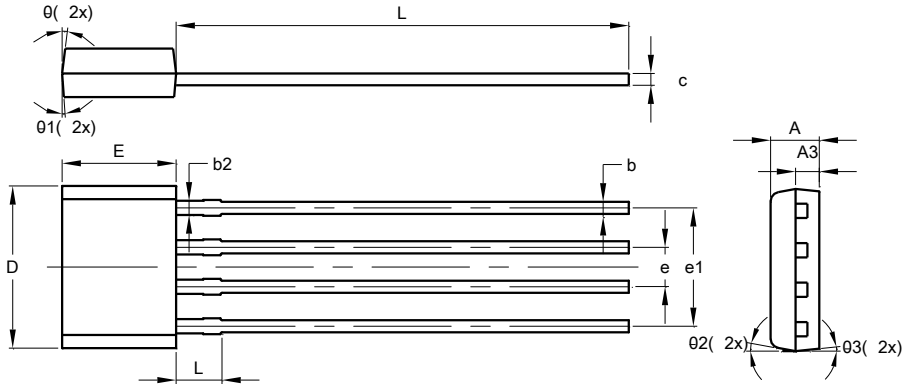

TO94			
Dim	Min	Max	Typ
A	1.46	1.66	1.56
A3	-	-	0.76
b	0.35	0.56	0.39
b2	-	-	0.46
c	0.36	0.51	0.38
D	5.12	5.32	5.22
E	3.55	3.75	3.65
e	-	-	1.27
e1	-	-	3.81
L	13.50	15.50	14.50
L1	-	-	1.42
S	0.63	0.83	0.73
theta	-	-	6°
theta1	-	-	4°
theta2	-	-	11°
theta3	-	-	6°
All Dimensions in mm			

Min/Max(in mm)

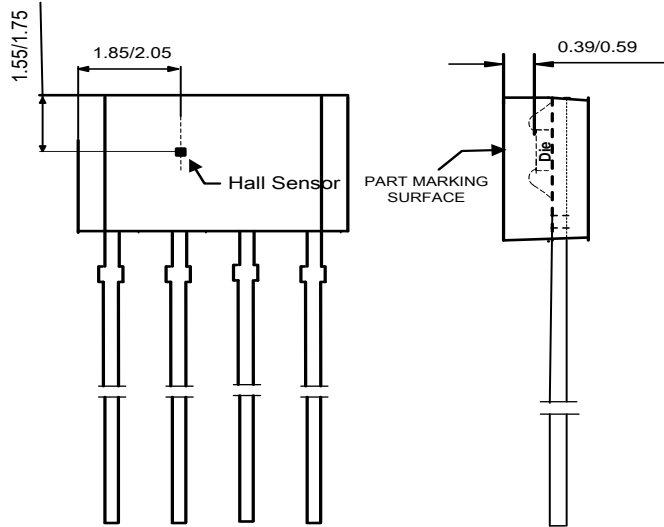

NEW PRODUCT

IMPORTANT NOTICE

DIODES INCORPORATED MAKES NO WARRANTY OF ANY KIND, EXPRESS OR IMPLIED, WITH REGARDS TO THIS DOCUMENT, INCLUDING, BUT NOT LIMITED TO, THE IMPLIED WARRANTIES OF MERCHANTABILITY AND FITNESS FOR A PARTICULAR PURPOSE (AND THEIR EQUIVALENTS UNDER THE LAWS OF ANY JURISDICTION).

Diodes Incorporated and its subsidiaries reserve the right to make modifications, enhancements, improvements, corrections or other changes without further notice to this document and any product described herein. Diodes Incorporated does not assume any liability arising out of the application or use of this document or any product described herein; neither does Diodes Incorporated convey any license under its patent or trademark rights, nor the rights of others. Any Customer or user of this document or products described herein in such applications shall assume all risks of such use and will agree to hold Diodes Incorporated and all the companies whose products are represented on Diodes Incorporated website, harmless against all damages.

Diodes Incorporated does not warrant or accept any liability whatsoever in respect of any products purchased through unauthorized sales channel. Should Customers purchase or use Diodes Incorporated products for any unintended or unauthorized application, Customers shall indemnify and hold Diodes Incorporated and its representatives harmless against all claims, damages, expenses, and attorney fees arising out of, directly or indirectly, any claim of personal injury or death associated with such unintended or unauthorized application.

Products described herein may be covered by one or more United States, international or foreign patents pending. Product names and markings noted herein may also be covered by one or more United States, international or foreign trademarks.

This document is written in English but may be translated into multiple languages for reference. Only the English version of this document is the final and determinative format released by Diodes Incorporated.

LIFE SUPPORT

Diodes Incorporated products are specifically not authorized for use as critical components in life support devices or systems without the express written approval of the Chief Executive Officer of Diodes Incorporated. As used herein:

A. Life support devices or systems are devices or systems which:

1. are intended to implant into the body, or
2. support or sustain life and whose failure to perform when properly used in accordance with instructions for use provided in the labeling can be reasonably expected to result in significant injury to the user.

B. A critical component is any component in a life support device or system whose failure to perform can be reasonably expected to cause the failure of the life support device or to affect its safety or effectiveness.

Customers represent that they have all necessary expertise in the safety and regulatory ramifications of their life support devices or systems, and acknowledge and agree that they are solely responsible for all legal, regulatory and safety-related requirements concerning their products and any use of Diodes Incorporated products in such safety-critical, life support devices or systems, notwithstanding any devices- or systems-related information or support that may be provided by Diodes Incorporated. Further, Customers must fully indemnify Diodes Incorporated and its representatives against any damages arising out of the use of Diodes Incorporated products in such safety-critical, life support devices or systems.

Copyright © 2015, Diodes Incorporated

www.diodes.com



Компания «ЭлектроПласт» предлагает заключение долгосрочных отношений при поставках импортных электронных компонентов на взаимовыгодных условиях!

Наши преимущества:

- Оперативные поставки широкого спектра электронных компонентов отечественного и импортного производства напрямую от производителей и с крупнейших мировых складов;
- Поставка более 17-ти миллионов наименований электронных компонентов;
- Поставка сложных, дефицитных, либо снятых с производства позиций;
- Оперативные сроки поставки под заказ (от 5 рабочих дней);
- Экспресс доставка в любую точку России;
- Техническая поддержка проекта, помощь в подборе аналогов, поставка прототипов;
- Система менеджмента качества сертифицирована по Международному стандарту ISO 9001;
- Лицензия ФСБ на осуществление работ с использованием сведений, составляющих государственную тайну;
- Поставка специализированных компонентов (Xilinx, Altera, Analog Devices, Intersil, Interpoint, Microsemi, Aeroflex, Peregrine, Syfer, Eurofarad, Texas Instrument, Miteq, Cobham, E2V, MA-COM, Hittite, Mini-Circuits, General Dynamics и др.);

Помимо этого, одним из направлений компании «ЭлектроПласт» является направление «Источники питания». Мы предлагаем Вам помощь Конструкторского отдела:

- Подбор оптимального решения, техническое обоснование при выборе компонента;
- Подбор аналогов;
- Консультации по применению компонента;
- Поставка образцов и прототипов;
- Техническая поддержка проекта;
- Защита от снятия компонента с производства.



Как с нами связаться

Телефон: 8 (812) 309 58 32 (многоканальный)

Факс: 8 (812) 320-02-42

Электронная почта: org@eplast1.ru

Адрес: 198099, г. Санкт-Петербург, ул. Калинина, дом 2, корпус 4, литера А.