

Features

- 75 Ω Input / Output Match
- -70 dBc CTB
- 3.0 dB Noise Figure
- 15 dB Gain
- Lead-Free SOT-89 Package
- Halogen-Free “Green” Mold Compound
- RoHS* Compliant and 260°C Reflow Compatible

Description

M/A-COM's MAAMSS0042 CATV amplifier is a GaAs MMIC which exhibits low distortion in a lead-free miniature surface mount plastic package. The MAAMSS0042 employs a monolithic single stage design featuring a convenient 75 Ω input/output impedance that minimizes the number of external components required.

The MAAMSS0042 provides low noise and high linearity. It is ideally suited for set top boxes, home gateways, FTTX, Drop Amplifiers, and other broadband internet based appliances.

The MAAMSS0042 is fabricated using M/A-COM's PHEMT process to realize low noise and low distortion. The process features full passivation for robust performance and reliability.

Functional Schematic

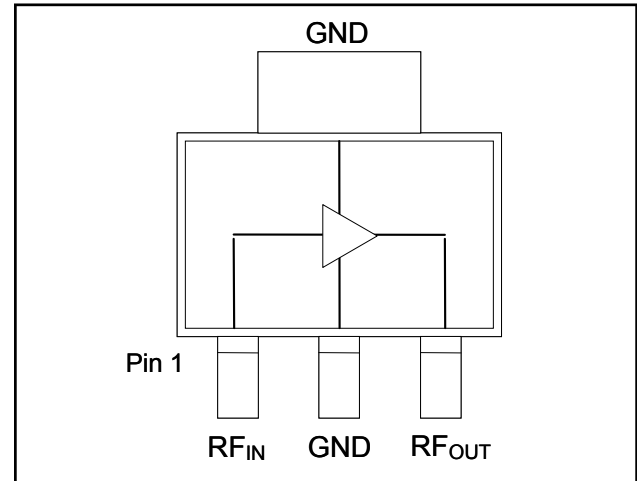

Pin Configuration

Pin No.	Pin Name	Description
1	RF _{IN}	RF Input
2	GND	Ground
3	RF _{OUT}	RF Output / Drain Supply

Ordering Information^{1,2}

Part Number	Package
MAAMSS0042	Bulk Packaging
MAAMSS0042TR	1000 piece reel
MAAMSS0042TR-3000	3000 piece reel
MAAMSS0042SMB	Sample Test Board

1. Reference Application Note M513 for reel size information.
2. All sample boards include 5 loose parts.

Absolute Maximum Ratings^{3,4,5}

Parameter	Absolute Maximum
RF Input Power	10 dBm
Voltage	10.0 volts
Operating Temperature	-20 °C to +85 °C
Junction Temperature ⁶	+150 °C
Storage Temperature	-65 °C to +150 °C

3. Exceeding any one or combination of these limits may cause permanent damage to this device.
4. M/A-COM does not recommend sustained operation near these survivability limits.
5. These operating conditions will ensure MTTF > 1 x 10⁶ hours.
6. Junction Temperature (T_J) = $T_C + \Theta_{jc} * (V * I)$
Typical thermal resistance (Θ_{jc}) = 59° C/W.
 - a) For $T_C = 25^\circ\text{C}$,
 $T_J = 57^\circ\text{C} @ 5\text{ V}, 110\text{ mA}$
 - b) For $T_C = 85^\circ\text{C}$,
 $T_J = 115^\circ\text{C} @ 5\text{ V}, 100\text{ mA}$

* Restrictions on Hazardous Substances, European Union Directive 2002/95/EC.

ADVANCED: Data Sheets contain information regarding a product M/A-COM Technology Solutions is considering for development. Performance is based on target specifications, simulated results, and/or prototype measurements. Commitment to develop is not guaranteed.
PRELIMINARY: Data Sheets contain information regarding a product M/A-COM Technology Solutions has under development. Performance is based on engineering tests. Specifications are typical. Mechanical outline has been fixed. Engineering samples and/or test data may be available. Commitment to produce in volume is not guaranteed.

• **North America** Tel: 800.366.2266 / Fax: 978.366.2266
 • **Europe** Tel: 44.1908.574.200 / Fax: 44.1908.574.300
 • **Asia/Pacific** Tel: 81.44.844.8296 / Fax: 81.44.844.8298
 Visit www.macomtech.com for additional data sheets and product information.

M/A-COM Technology Solutions Inc. and its affiliates reserve the right to make changes to the product(s) or information contained herein without notice.

Electrical Specifications: $T_A = 25^\circ\text{C}$, Freq: 50 - 1000 MHz, $V_{DD} = 5$ Volts, $Z_0 = 75 \Omega$

Parameter	Test Conditions	Units	Min.	Typ.	Max.
Gain		dB	13.8	15	16.0
Gain Flatness		dB	—	0.8	1.2
Noise Figure		dB	—	3.0	4.0
Input Return Loss		dB	—	20	—
Output Return Loss		dB	—	18	—
Output IP3	6 MHz Spacing, -10 dBm output per tone	dBm	—	38	—
Composite Triple Beat, CTB	132 channels, +30 dBmV / channel at the output.	dBc	—	-70	—
Composite Second Order, CSO	132 channels, +30 dBmV / channel at the output.	dBc	—	-70	—
P1dB		dBm	—	21	—
I_{DD}	5 Volts	mA	—	110	130

Schematic Including Off-Chip Components

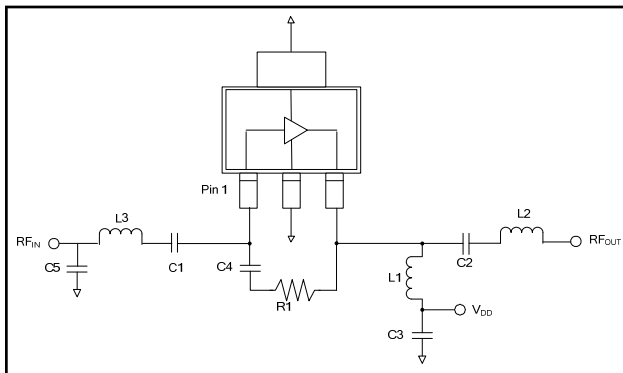

Off-Chip Component Values

Component	Value	Package
C1,C2,C3,C4	0.01 μF	0402
C5	0.8 pF	0402
L1 ⁷	1 μH	1210
L2	4.7 nH	0402
L3	6.8 nH	0402
R1	523 Ω	0402

7. L1 supplied from EPCOS, part number B82422A1102K100

Recommended Board Layout

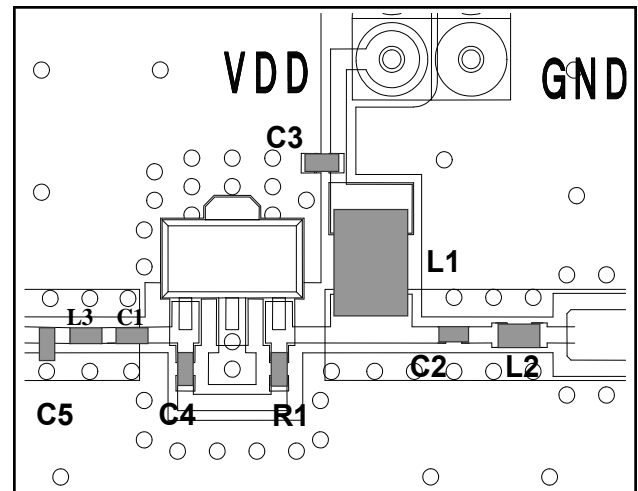

Typical Performance Curves

Gain vs. Frequency over Temperature to 1 GHz

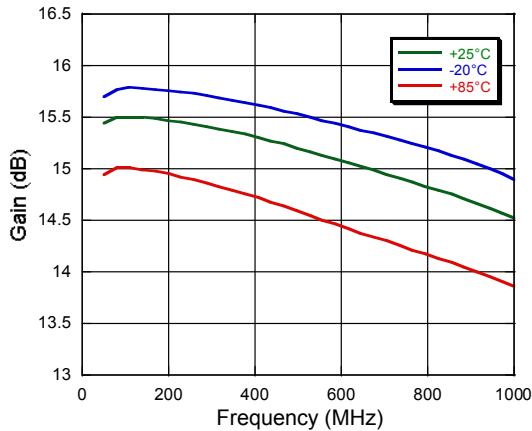

Gain vs. Frequency over Temperature to 3 GHz

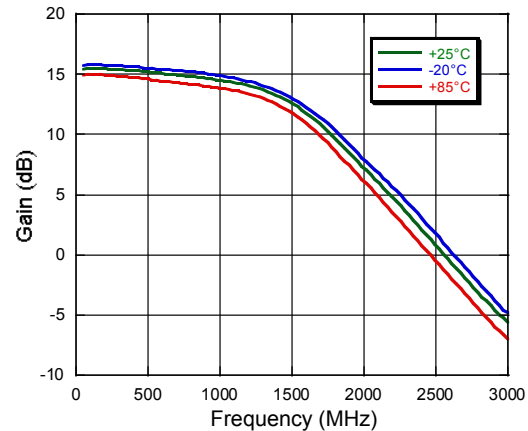

Input Return Loss vs. Frequency over Temperature

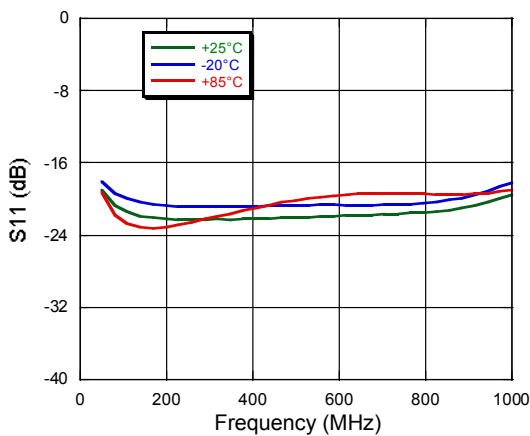

Output Return Loss vs. Frequency over Temperature

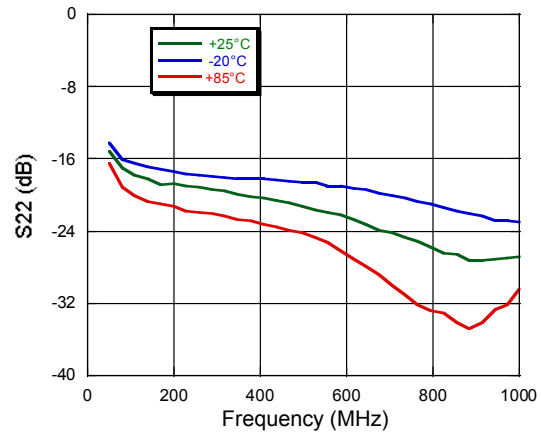

Noise Figure vs. Frequency

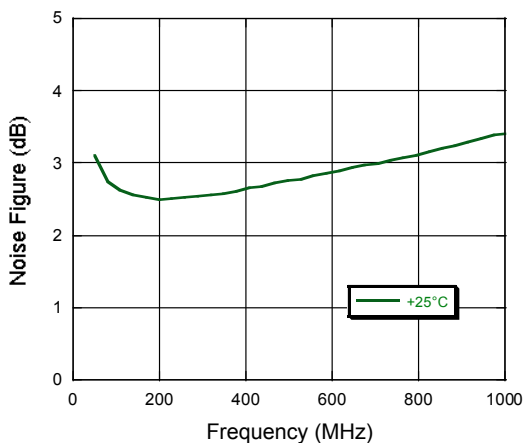

Lead Free SOT-89 Plastic Package

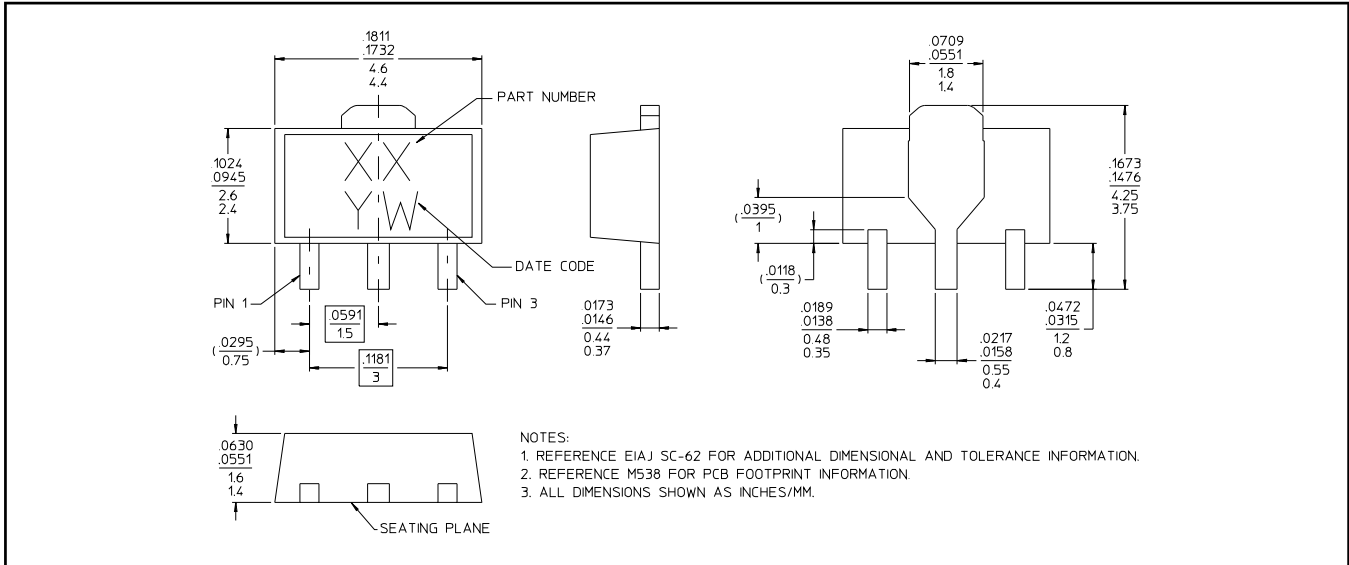

† Reference Application Note M538 for lead-free solder reflow recommendations.
Meets JEDEC moisture sensitivity level 1 requirements.
Plating is 100% matte tin over copper.

Handling Procedures

Please observe the following precautions to avoid damage:

Static Sensitivity

Gallium Arsenide Integrated Circuits are sensitive to electrostatic discharge (ESD) and can be damaged by static electricity. Proper ESD control techniques should be used when handling these devices.



Компания «ЭлектроПласт» предлагает заключение долгосрочных отношений при поставках импортных электронных компонентов на взаимовыгодных условиях!

Наши преимущества:

- Оперативные поставки широкого спектра электронных компонентов отечественного и импортного производства напрямую от производителей и с крупнейших мировых складов;
- Поставка более 17-ти миллионов наименований электронных компонентов;
- Поставка сложных, дефицитных, либо снятых с производства позиций;
- Оперативные сроки поставки под заказ (от 5 рабочих дней);
- Экспресс доставка в любую точку России;
- Техническая поддержка проекта, помощь в подборе аналогов, поставка прототипов;
- Система менеджмента качества сертифицирована по Международному стандарту ISO 9001;
- Лицензия ФСБ на осуществление работ с использованием сведений, составляющих государственную тайну;
- Поставка специализированных компонентов (Xilinx, Altera, Analog Devices, Intersil, Interpoint, Microsemi, Aeroflex, Peregrine, Syfer, Eurofarad, Texas Instrument, Miteq, Cobham, E2V, MA-COM, Hittite, Mini-Circuits, General Dynamics и др.);

Помимо этого, одним из направлений компании «ЭлектроПласт» является направление «Источники питания». Мы предлагаем Вам помощь Конструкторского отдела:

- Подбор оптимального решения, техническое обоснование при выборе компонента;
- Подбор аналогов;
- Консультации по применению компонента;
- Поставка образцов и прототипов;
- Техническая поддержка проекта;
- Защита от снятия компонента с производства.



Как с нами связаться

Телефон: 8 (812) 309 58 32 (многоканальный)

Факс: 8 (812) 320-02-42

Электронная почта: org@eplast1.ru

Адрес: 198099, г. Санкт-Петербург, ул. Калинина, дом 2, корпус 4, литера А.