

# KAI-2020

## 1600 (H) x 1200 (V) Interline CCD Image Sensor

### Description

The KAI-2020 Image Sensor is a high-performance 2-million pixel sensor designed for a wide range of medical, scientific and machine vision applications. The 7.4  $\mu\text{m}$  square pixels with microlenses provide high sensitivity and the large full well capacity results in high dynamic range. The split horizontal register offers a choice of single or dual output allowing either 18 or 35 frame per second (fps) video rate for the progressively scanned images. Also included is a fast line dump for sub-sampling at higher frame rates. The vertical overflow drain structure provides antiblooming protection and enables electronic shuttering for precise exposure control. Other features include low dark current, negligible lag and low smear.

Table 1. GENERAL SPECIFICATIONS

Parameter	Typical Value
Architecture	Interline CCD, Progressive Scan
Total Number of Pixels	1640 (H) $\times$ 1214 (V)
Number of Effective Pixels	1608 (H) $\times$ 1208 (V)
Number of Active Pixels	1600 (H) $\times$ 1200 (V)
Pixel Size	7.4 $\mu\text{m}$ (H) $\times$ 7.4 $\mu\text{m}$ (V)
Active Image Size	11.84 mm (H) $\times$ 8.88 mm (V), 14.80 mm (Diagonal)
Aspect Ratio	4:3
Number of Outputs	1 or 2
Saturation Signal 40 MHz 20 MHz	20,000 e <sup>-</sup> 40,000 e <sup>-</sup>
Output Sensitivity	30 $\mu\text{V}/\text{e}^-$
Quantum Efficiency -ABA (460 nm) -CBA (620 nm, 540 nm, 460 nm)	55% 45%, 42%, 35%
Readout Noise 40 MHz 20 MHz	20 electrons 16 electrons
Dynamic Range 40 MHz 20 MHz	60 dB 68 dB
Dark Current	< 0.5 nA/cm <sup>2</sup>
Maximum Pixel Clock Speed	40 MHz
Maximum Frame Rate Dual Output Single Output	35 fps 18 fps
Package Type	32 pin CerDIP
Package Size	0.790" [20.07 mm] width 1.300" [33.02 mm] length
Package Pin Spacing	0.070"
Cover Glass	AR coated, 2 sides

NOTE: Parameters above are specified at T = 40°C unless otherwise noted.



ON Semiconductor®

[www.onsemi.com](http://www.onsemi.com)

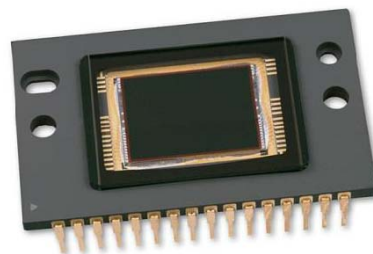

Figure 1. KAI-2020 Interline CCD Image Sensor

### Features

- High Resolution
- High Sensitivity
- High Dynamic Range
- Low Noise Architecture
- High Frame Rate
- Binning Capability for Higher Frame Rate
- Electronic Shutter

### Applications

- Intelligent Transportation Systems
- Machine Vision
- Scientific
- Surveillance

### ORDERING INFORMATION

See detailed ordering and shipping information on page 2 of this data sheet.

# KAI-2020

## ORDERING INFORMATION

**Table 2. ORDERING INFORMATION – KAI-2020 IMAGE SENSOR**

Part Number	Description	Marking Code
KAI-2020-AAA-CR-BA	Monochrome, No Microlens, CERDIP Package (Sidebrazed), Taped Clear Cover Glass with AR Coating (2 Sides), Standard Grade	KAI-2020 Serial Number
KAI-2020-AAA-CR-AE	Monochrome, No Microlens, CERDIP Package (Sidebrazed), Taped Clear Cover Glass with AR Coating (2 Sides), Engineering Sample	
KAI-2020-AAA-CF-BA	Monochrome, No Microlens, CERDIP Package (Sidebrazed), Quartz Cover Glass (No Coatings), Standard Grade	
KAI-2020-AAA-CF-AE	Monochrome, No Microlens, CERDIP Package (Sidebrazed), Quartz Cover Glass (No Coatings), Engineering Sample	
KAI-2020-ABA-CD-BA	Monochrome, Telecentric Microlens, CERDIP Package (Sidebrazed), Clear Cover Glass with AR Coating (Both Sides), Standard Grade	KAI-2020M Serial Number
KAI-2020-ABA-CD-AE	Monochrome, Telecentric Microlens, CERDIP Package (Sidebrazed), Clear Cover Glass with AR Coating (Both Sides), Engineering Sample	
KAI-2020-ABA-CR-BA	Monochrome, Telecentric Microlens, CERDIP Package (Sidebrazed), Taped Clear Cover Glass with AR Coating (2 sides), Standard Grade	
KAI-2020-ABA-CR-AE	Monochrome, Telecentric Microlens, CERDIP Package (Sidebrazed), Taped Clear Cover Glass with AR Coating (2 sides), Engineering Sample	
KAI-2020-CBA-CD-BA	Color (Bayer RGB), Telecentric Microlens, CERDIP Package (Sidebrazed), Clear Cover Glass with AR Coating (Both Sides), Standard Grade	KAI-2020CM Serial Number
KAI-2020-CBA-CD-AE	Color (Bayer RGB), Telecentric Microlens, CERDIP Package (Sidebrazed), Clear Cover Glass with AR Coating (Both Sides), Engineering Sample	
KAI-2020-CBA-CR-BA	Color (Bayer RGB), Telecentric Microlens, CERDIP Package (Sidebrazed), Taped Clear Cover Glass with AR Coating (2 Sides), Standard Grade	
KAI-2020-CBA-CR-AE	Color (Bayer RGB), Telecentric Microlens, CERDIP Package (Sidebrazed), Taped Clear Cover Glass with AR Coating (2 Sides), Engineering Sample	

**Table 3. ORDERING INFORMATION – EVALUATION SUPPORT**

Part Number	Description
KAI-2020-12-20-A-EVK	Evaluation Board, 12 Bit, 20 MHz (Complete Kit)
KAI-2020-10-40-A-EVK	Evaluation Board, 10 Bit, 40 MHz (Complete Kit)

See the ON Semiconductor *Device Nomenclature* document (TND310/D) for a full description of the naming convention used for image sensors. For reference documentation, including information on evaluation kits, please visit our web site at [www.onsemi.com](http://www.onsemi.com).

DEVICE DESCRIPTION

Architecture

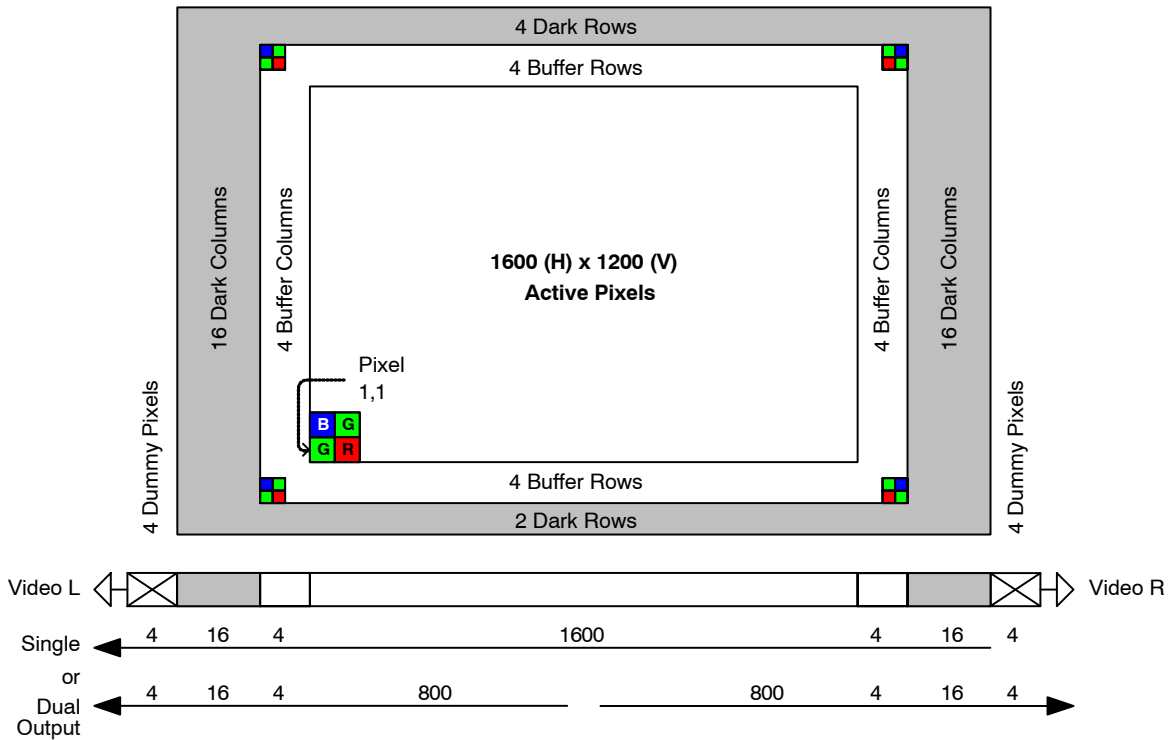

Figure 2. Sensor Architecture

There are 2 light shielded rows followed 1,208 photoactive rows and finally 4 more light shielded rows. The first 4 and the last 4 photoactive rows are buffer rows giving a total of 1,200 lines of image data.

In the single output mode all pixels are clocked out of the Video L output in the lower left corner of the sensor. The first 4 empty pixels of each line do not receive charge from the vertical shift register. The next 16 pixels receive charge from the left light shielded edge followed by 1608 photosensitive pixels and finally 16 more light shielded pixels from the right edge of the sensor. The first and last 4 photosensitive

pixels are buffer pixels giving a total of 1600 pixels of image data.

In the dual output mode the clocking of the right half of the horizontal CCD is reversed. The left half of the image is clocked out Video L and the right half of the image is clocked out Video R. Each row consists of 4 empty pixels followed by 16 light shielded pixels followed by 800 photosensitive pixels. When reconstructing the image, data from Video R will have to be reversed in a line buffer and appended to the Video L data.

Pixel

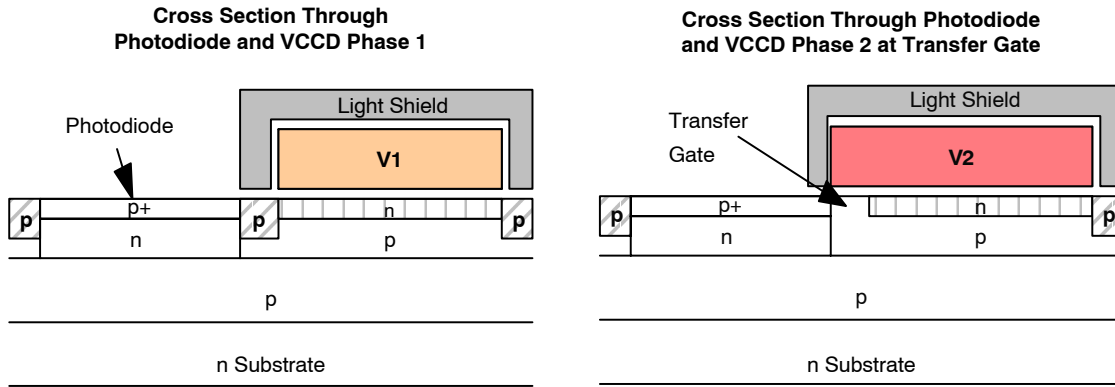

NOTE: Drawings not scale.

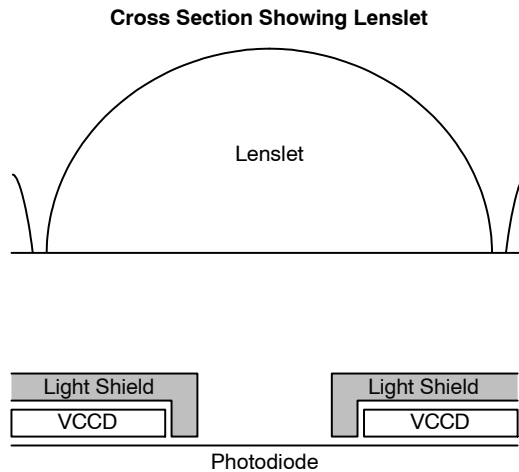

Figure 3. Pixel Architecture

An electronic representation of an image is formed when incident photons falling on the sensor plane create electron-hole pairs within the individual silicon photodiodes. These photoelectrons are collected locally by the formation of potential wells at each photosite. Below photodiode saturation, the number of photoelectrons

collected at each pixel is linearly dependent upon light level and exposure time and non-linearly dependent on wavelength. When the photodiodes charge capacity is reached, excess electrons are discharged into the substrate to prevent blooming.

Vertical to Horizontal Transfer

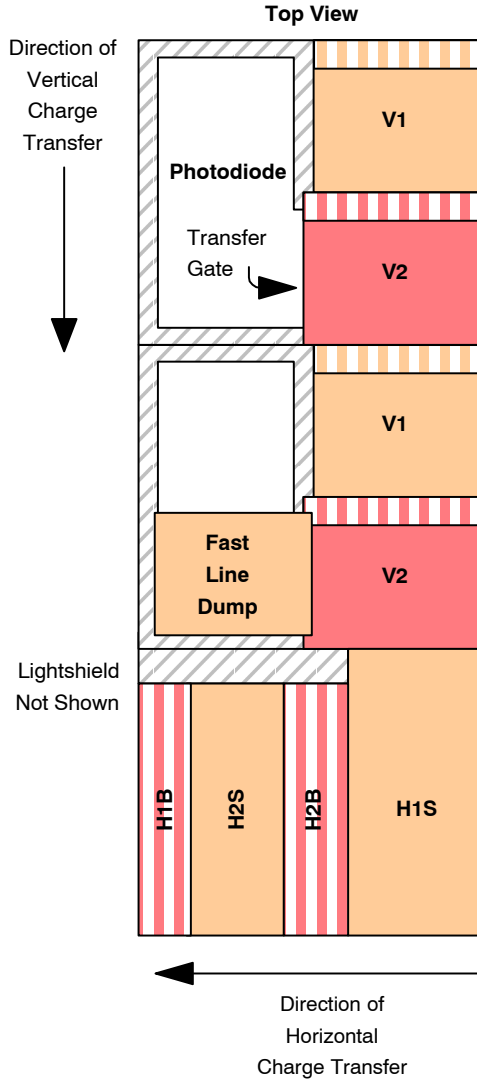

Figure 4. Vertical to Horizontal Transfer Architecture

When the V1 and V2 timing inputs are pulsed, charge in every pixel of the VCCD is shifted one row towards the HCCD. The last row next to the HCCD is shifted into the HCCD. When the VCCD is shifted, the timing signals to the HCCD must be stopped. H1 must be stopped in the high state and H2 must be stopped in the low state. The HCCD clocking may begin  $T_{HD}$   $\mu$ s after the falling edge of the V1 and V2 pulse.

Charge is transferred from the last vertical CCD phase into the H1S horizontal CCD phase. Refer to Figure 28 for an example of timing that accomplishes the vertical to horizontal transfer of charge.

If the fast line dump is held at the high level (FDH) during a vertical to horizontal transfer, then the entire line is removed and not transferred into the horizontal register.

Horizontal Register to Floating Diffusion

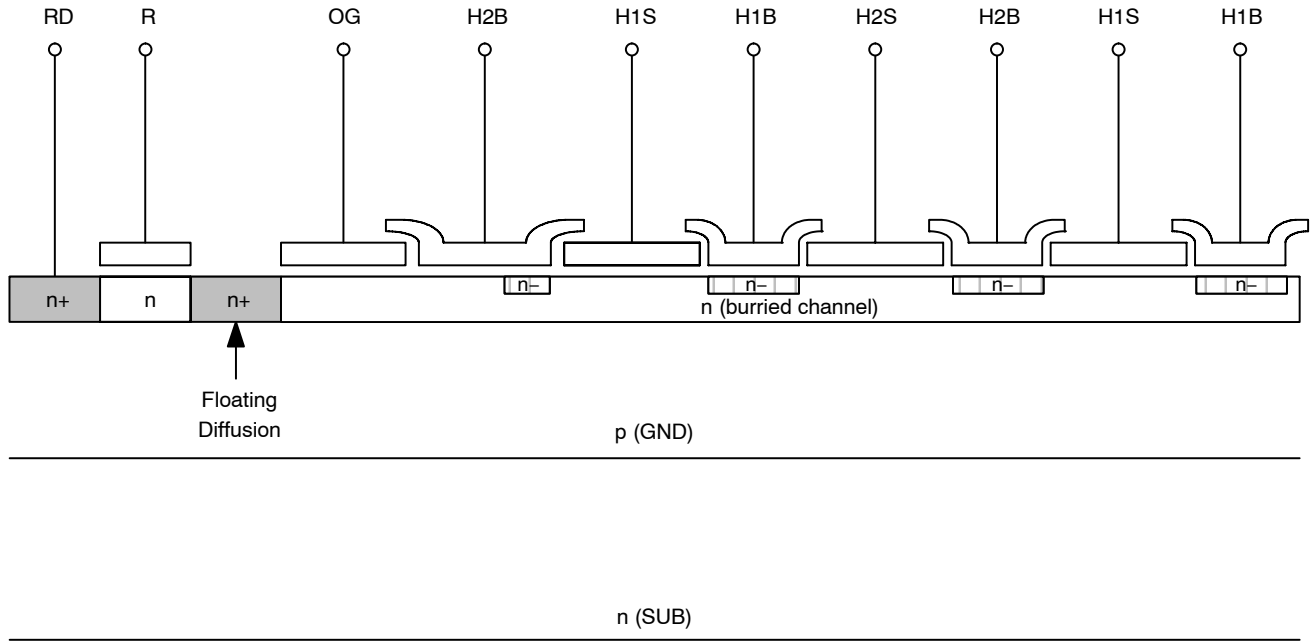

Figure 5. Horizontal Register to Floating Diffusion Architecture

The HCCD has a total of 1648 pixels. The 1640 vertical shift registers (columns) are shifted into the center 1640 pixels of the HCCD. There are 4 pixels at both ends of the HCCD, which receive no charge from a vertical shift register. The first 4 clock cycles of the HCCD will be empty pixels (containing no electrons). The next 16 clock cycles will contain only electrons generated by dark current in the VCCD and photodiodes. The next 1608 clock cycles will contain photo-electrons (image data). Finally, the last 16 clock cycles will contain only electrons generated by dark current in the VCCD and photodiodes. Of the 16 dark columns, the first and last dark columns should not be used for determining the zero signal level. Some light does leak into the first and last dark columns. Only use the center 14 columns of the 16 column dark reference.

When the HCCD is shifting valid image data, the timing inputs to the electronic shutter (SUB), VCCD (V1, V2), and fast line dump (FD) should not be pulsed. This prevents unwanted noise from being introduced. The HCCD is a type of charge coupled device known as a pseudo-two phase CCD. This type of CCD has the ability to shift charge in two directions. This allows the entire image to be shifted out to the video L output, or to the video R output (left/right image reversal). The HCCD is split into two equal halves of 824 pixels each. When operating the sensor in single output mode the two halves of the HCCD are shifted in the same direction. When operating the sensor in dual output mode the two halves of the HCCD are shifted in opposite directions. The direction of charge transfer in each half is controlled by the H1BL, H2BL, H1BR, and H2BR timing inputs.

Horizontal Register Split

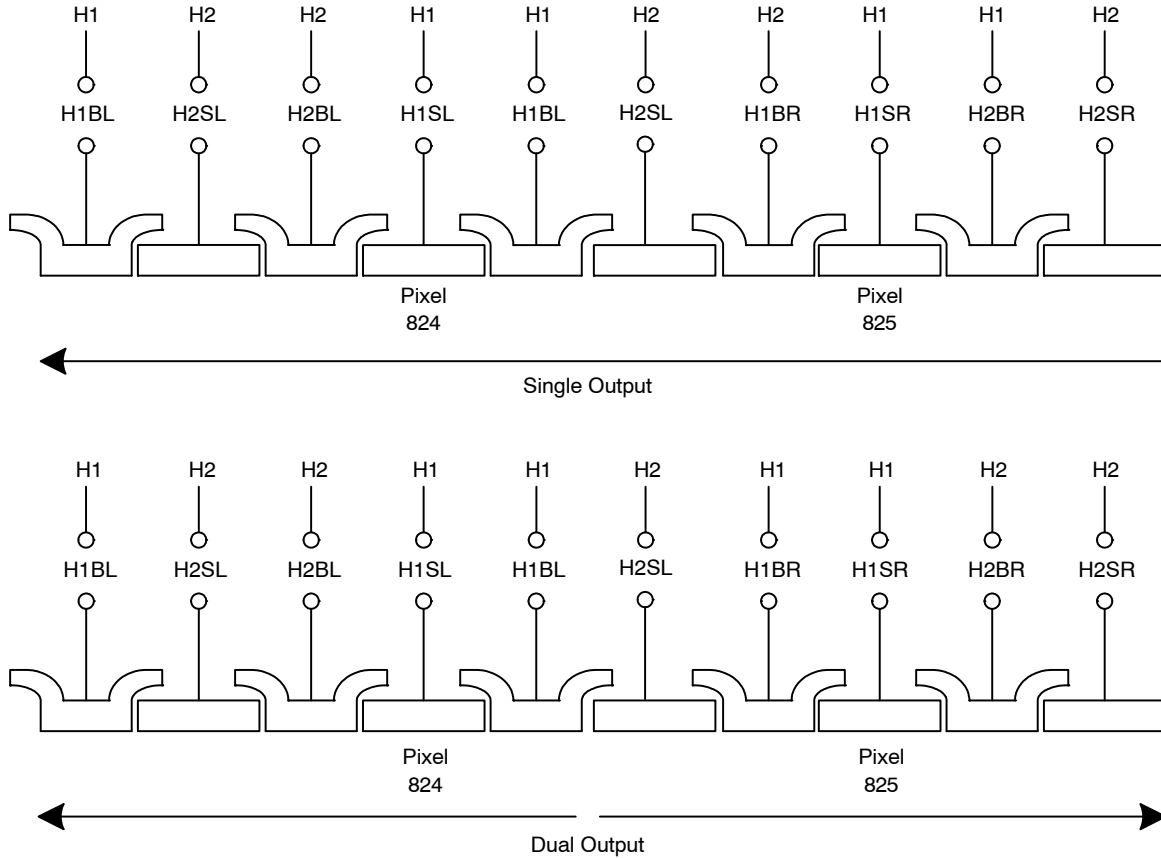

Figure 6. Horizontal Register

Single Output Operation

When operating the sensor in single output mode all pixels of the image sensor will be shifted out the Video L output (pin 31). To conserve power and lower heat generation the output amplifier for Video R may be turned off by connecting VDDR (pin 24) and VOUTR (pin 24) to GND (zero volts).

The H1 timing from the timing diagrams should be applied to H1SL, H1BL, H1SR, H2BR, and the H2 timing should be applied to H2SL, H2BL, H2SR, and H1BR. In other words, the clock driver generating the H1 timing should be connected to pins 4, 3, 13, and 15. The clock driver generating the H2 timing should be connected to pins 5, 2, 12, and 14. The horizontal CCD should be clocked for 4 empty pixels plus 16 light shielded pixels plus 1608 photoactive pixels plus 16 light shielded pixels for a total of 1644 pixels.

Dual Output Operation

In dual output mode the connections to the H1BR and H2BR pins are swapped from the single output mode to change the direction of charge transfer of the right side horizontal shift register. In dual output mode both VDDL and VDDR (pins 25, 24) should be connected to 15 V. The H1 timing from the timing diagrams should be applied to H1SL, H1BL, H1SR, H1BR, and the H2 timing should be applied to H2SL, H2BL, H2SR, and H2BR. The clock driver generating the H1 timing should be connected to pins 4, 3, 13, and 14. The clock driver generating the H2 timing should be connected to pins 5, 2, 12, and 15. The horizontal CCD should be clocked for 4 empty pixels plus 16 light shielded pixels plus 804 photoactive pixels for a total of 824 pixels. If the camera is to have the option of dual or single output mode, the clock driver signals sent to H1BR and H2BR may be swapped by using a relay. Another alternative is to have two extra clock drivers for H1BR and H2BR and invert the signals in the timing logic generator. If two extra clock drivers are used, care must be taken to ensure the rising and falling edges of the H1BR and H2BR clocks occur at the same time (within 3 ns) as the other HCCD clocks.

## Output

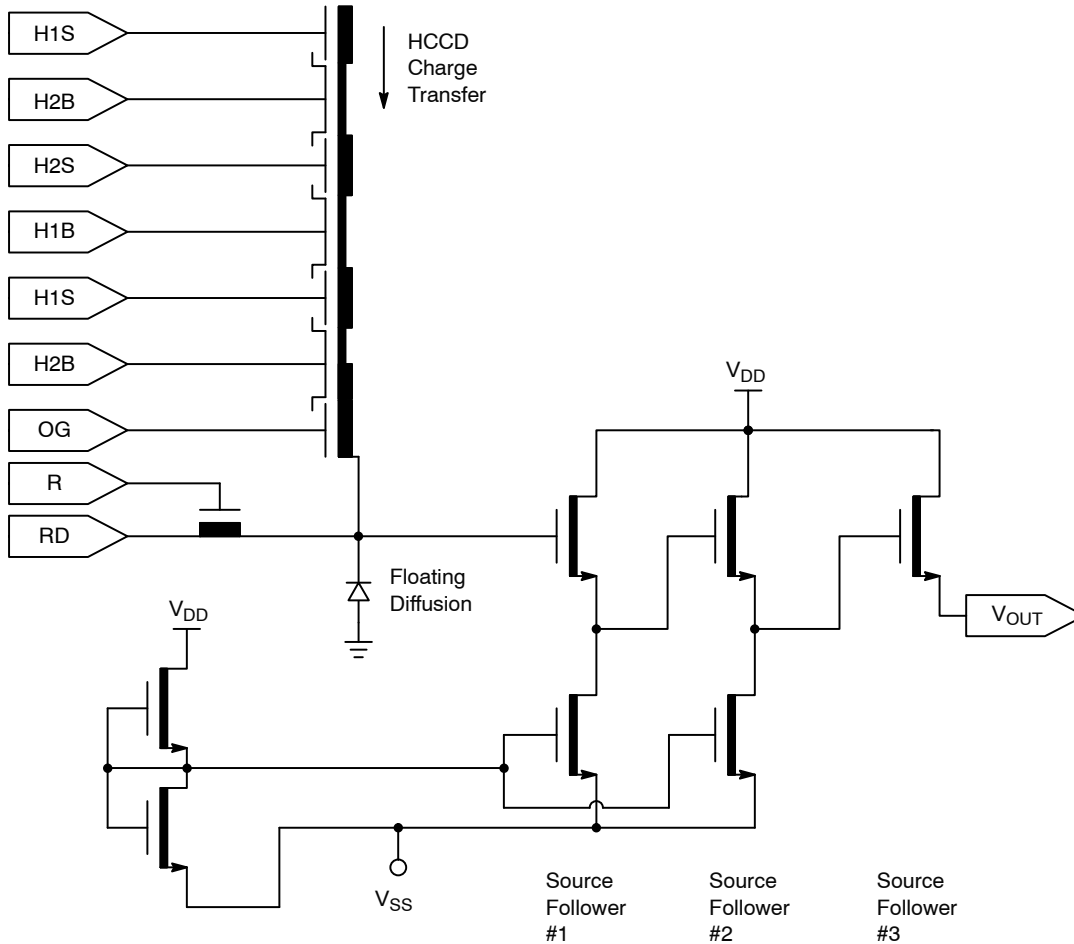

Figure 7. Output Architecture

Charge packets contained in the horizontal register are dumped pixel by pixel onto the floating diffusion (FD) output node whose potential varies linearly with the quantity of charge in each packet. The amount of potential charge is determined by the expression  $\Delta V_{FD} = \Delta Q / C_{FD}$ . A three-stage source-follower amplifier is used to buffer this signal voltage off chip with slightly less than unity gain. The translation from the charge domain to the voltage domain is quantified by the output sensitivity or charge to voltage conversion in terms of microvolts per electron ( $\mu\text{V}/e^-$ ). After the signal has been sampled off chip, the reset clock (R) removes the charge from the floating diffusion and resets its potential to the reset drain voltage (RD).

When the image sensor is operated in the binned or summed interlaced modes there will be more than 20,000  $e^-$  in the output signal. The image sensor is designed with a 30  $\mu\text{V}/e^-$  charge to voltage conversion on the output. This means a full signal of 20,000 electrons will produce a 600 mV change on the output amplifier. The output amplifier was designed to handle an output swing of 600 mV at a pixel rate of 40 MHz. If 40,000 electron charge packets

are generated in the binned or summed interlaced modes then the output amplifier output will have to swing 1,200 mV. The output amplifier does not have enough bandwidth (slew rate) to handle 1,200 mV at 40 MHz. Hence, the pixel rate will have to be reduced to 20 MHz if the full dynamic range of 40,000 electrons is desired.

The charge handling capacity of the output amplifier is also set by the reset clock voltage levels. The reset clock driver circuit is very simple if an amplitude of 5 V is used. But the 5 V amplitude restricts the output amplifier charge capacity to 20,000 electrons. If the full dynamic range of 40,000 electrons is desired then the reset clock amplitude will have to be increased to 7 V.

If you only want a maximum signal of 20,000 electrons in binned or summed interlaced modes, then a 40 MHz pixel rate with a 5 V reset clock may be used. The output of the amplifier will be unpredictable above 20,000 electrons so be sure to set the maximum input signal level of your analog to digital converter to the equivalent of 20,000 electrons (600 mV).



# KAI-2020

The following table summarizes the previous explanation on the output amplifier's operation. Certain trade-offs can

be made based on application needs such as Dynamic Range or Pixel frequency.

**Table 4.**

Pixel Frequency (MHz)	Reset Clock Amplitude (V)	Output Gate (V)	Saturation Signal (mV)	Saturation Signal (Ke <sup>-</sup> )	Dynamic Range (dB)	Notes
40	5	-2.0	600	20	60	
20	5	-2.0	600	20	62	
20	7	-3	1200	40	68	
20	7	-3	2400	80	74	1

1. 80,000 electrons achievable in summed interlaced or binning modes.

## ESD Protection

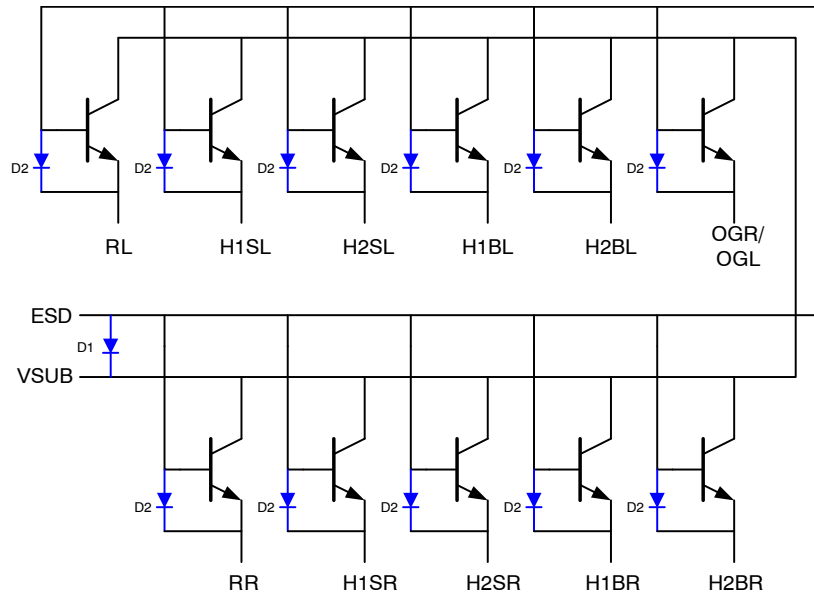

**Figure 8. ESD Protection**

The ESD protection on the KAI-2020 is implemented using bipolar transistors. The substrate (VSUB) forms the common collector of all the ESD protection transistors. The ESD pin is the common base of all the ESD protection transistors. Each protected pin is connected to a separate emitter as shown in Figure 8.

The ESD circuit turns on if the base-emitter junction voltage exceeds 17 V. Care must be taken while operating the image sensor, especially during the power on sequence, to not forward bias the base-emitter or base-collector

junctions. If it is possible for the camera power up sequence to forward bias these junctions then diodes D1 and D2 should be added to protect the image sensor. Put one diode D1 between the ESD and VSUB pins. Put one diode D2 on each pin that may forward bias the base-emitter junction. The diodes will prevent large currents from flowing through the image sensor.

Note that diodes D1 and D2 are added external to the KAI-2020. These diodes are optional in camera design.

PHYSICAL DESCRIPTION

Pin Description and Device Orientation

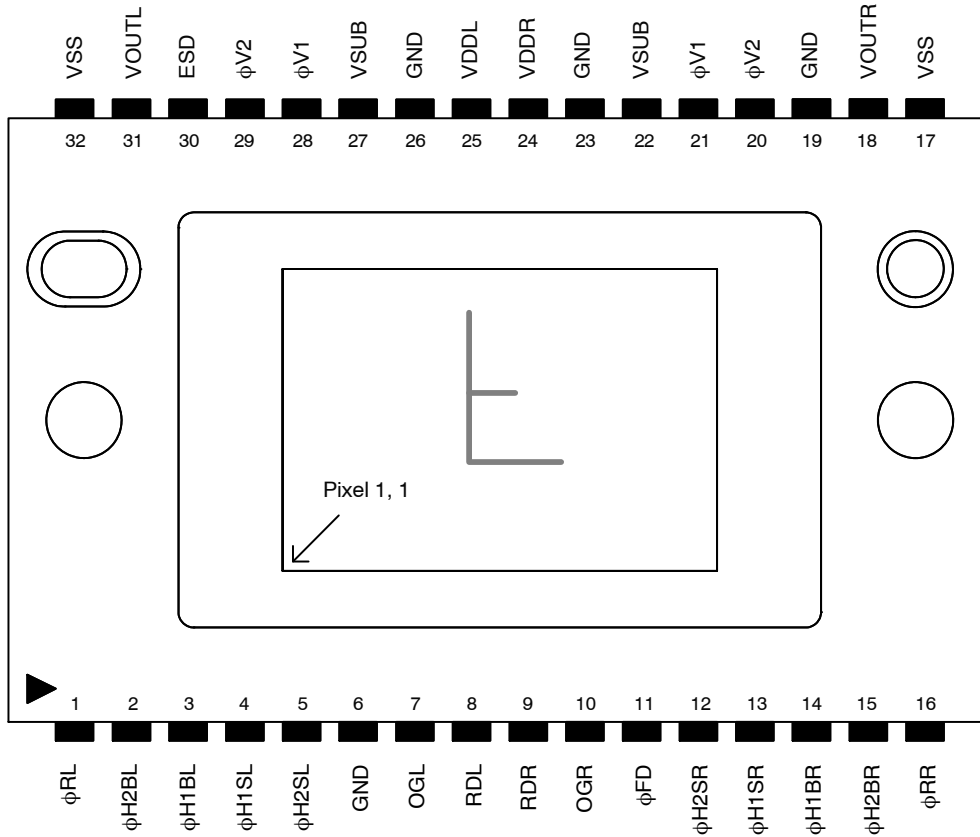

Figure 9. Package Pin Designations – Top View

Table 5. PIN DESCRIPTION

Pin	Name	Description
1	$\phi$ RL	Reset Gate, Left
2	$\phi$ H2BL	H2 Barrier, Left
3	$\phi$ H1BL	H1 Barrier, Left
4	$\phi$ H1SL	H1 Storage, Left
5	$\phi$ H2SL	H2 Storage, Left
6	GND	Ground
7	OGL	Output Gate, Left
8	RDL	Reset Drain, Left
9	RDR	Reset Drain, Right
10	ORG	Output Gate, Right
11	FD	Fast Line Dump Gate
12	$\phi$ H2SR	H2 Storage, Right
13	$\phi$ H1SR	H1 Storage, Right
14	$\phi$ H1BR	H1 Barrier, Right
15	$\phi$ H2BR	H2 Barrier, Right
16	$\phi$ RR	Reset Gate, Right

Pin	Name	Description
17	VSS	Output Amplifier Return
18	VOU <sub>TR</sub>	Video Output, Right
19	GND	Ground
20	$\phi$ V2	Vertical Clock, Phase 2
21	$\phi$ V1	Vertical Clock, Phase 1
22	VSUB	Substrate
23	GND	Ground
24	VDDR	V <sub>DD</sub> , Right
25	VDDL	V <sub>DD</sub> , Left
26	GND	Ground
27	VSUB	Substrate
28	$\phi$ V1	Vertical Clock, Phase 1
29	$\phi$ V2	Vertical Clock, Phase 2
30	ESD	ESD
31	VOU <sub>TL</sub>	Video Output, Left
32	VSS	Output Amplifier Return

NOTE: The pins are on a 0.07" spacing.

## IMAGING PERFORMANCE

**Table 6. TYPICAL OPERATIONAL CONDITIONS**

(Unless otherwise noted, the Imaging Performance Specifications are measured using the following conditions.)

Description	Condition	Notes
Frame Time	237 ms	1
Horizontal Clock Frequency	10 MHz	
Light Source (LED)	Continuous Red, Green and Blue Illumination Centered at 450, 530 and 650 nm	2, 3
Operation	Nominal Operating Voltages and Timing	

1. Electronic shutter is not used. Integration time equals frame time.
2. LEDs used: Blue: Nichia NLPB500, Green: Nichia NSPG500S and Red: HP HLMP-8115.
3. For monochrome sensor, only green LED used.

## Specifications

**Table 7. PERFORMANCE SPECIFICATIONS**

Description	Symbol	Min.	Nom.	Max.	Unit	Sampling Plan	Temperature Tested at (°C)
<b>ALL CONFIGURATIONS</b>							
Dark Center Uniformity		N/A	N/A	20	e <sup>-</sup> rms	Die	27, 40
Dark Global Uniformity		N/A	N/A	5.0	mVpp	Die	27, 40
Global Uniformity (Note 1)		N/A	2.5	5.0	% rms	Die	27, 40
Global Peak to Peak Uniformity (Note 1)	PRNU	N/A	10	20	% pp	Die	27, 40
Center Uniformity (Note 1)		N/A	1.0	2.0	% rms	Die	27, 40
Maximum Photoresponse Non-Linearity (Notes 2, 3)	NL	N/A	2	-	%	Design	
Maximum Gain Difference between Outputs (Notes 2, 3)	ΔG	N/A	10	-	%	Design	
Max. Signal Error due to Non-Linearity Dif. (Notes 2, 3)	ΔNL	N/A	1	-	%	Design	
Horizontal CCD Charge Capacity	H <sub>Ne</sub>	N/A	100	N/A	ke <sup>-</sup>	Design	
Vertical CCD Charge Capacity	V <sub>Ne</sub>	N/A	50	N/A	ke <sup>-</sup>	Die	
Photodiode Charge Capacity (20 MHz)	P <sub>Ne</sub>	38	40	N/A	ke <sup>-</sup>	Die	
Photodiode Charge Capacity (40 MHz)	P <sub>Ne</sub>	19	20	N/A	ke <sup>-</sup>	Die	
Horizontal CCD Charge Transfer Efficiency	HCTE	0.99999	N/A	N/A		Design	
Vertical CCD Charge Transfer Efficiency	VCTE	0.99999	N/A	N/A		Design	
Photodiode Dark Current	I <sub>PD</sub>	N/A N/A	40 0.01	350 0.1	e/p/s nA/cm <sup>2</sup>	Die	40
Vertical CCD Dark Current	I <sub>VD</sub>	N/A N/A	400 0.12	1,711 0.5	e/p/s nA/cm <sup>2</sup>	Die	40
Image Lag	Lag	N/A	< 10	50	e <sup>-</sup>	Design	
Anti-Blooming Factor	X <sub>AB</sub>	100	300	N/A		Design	
Vertical Smear	Smr	N/A	80	75	dB	Design	
Sensor Read Noise (20 MHz)	n <sub>e-T</sub>	-	16	-	e <sup>-</sup> rms	Design	
Sensor Read Noise (40 MHz)	n <sub>e-T</sub>	-	20	-	e <sup>-</sup> rms	Design	

# KAI-2020

**Table 7. PERFORMANCE SPECIFICATIONS** (continued)

Description	Symbol	Min.	Nom.	Max.	Unit	Sampling Plan	Temperature Tested at (°C)
<b>ALL CONFIGURATIONS</b>							
Dynamic Range (Note 4) 20 MHz 40 MHz	DR	- -	68 60	- -	dB	Design	
Output Amplifier DC Offset	V <sub>ODC</sub>	4	8.5	14	V	Die	
Output Amplifier Bandwidth	f <sub>-3DB</sub>	-	140	-	MHz	Design	
Output Amplifier Impedance	R <sub>OUT</sub>	100	130	200	Ω	Die	
Output Amplifier Sensitivity	ΔV/ΔN	-	30	-	μV/e <sup>-</sup>	Design	
<b>KAI-2020-ABA CONFIGURATION</b>							
Peak Quantum Efficiency	QE <sub>MAX</sub>	45	55	N/A	%	Design	
Peak Quantum Efficiency Wavelength	λ <sub>QE</sub>	N/A	460	N/A	nm	Design	
<b>KAI-2020-CBA CONFIGURATION</b>							
Peak Quantum Efficiency Red Green Blue	QE <sub>MAX</sub>	- - -	31 37 41	N/A N/A N/A	%	Design	
Peak Quantum Efficiency Wavelength Red Green Blue	λ <sub>QE</sub>	- - -	460 540 620	N/A N/A N/A	nm	Design	

NOTE: N/A = Not Applicable.

1. For KAI-2020-CBA, per color.
2. Value is over the range of 10% to 90% of photodiode saturation.
3. Value is for the sensor operated without binning.
4. Uses 20LOG (P<sub>Ne</sub> / n<sub>e-T</sub>).

TYPICAL PERFORMANCE CURVES

Quantum Efficiency

*Monochrome with Microlens*

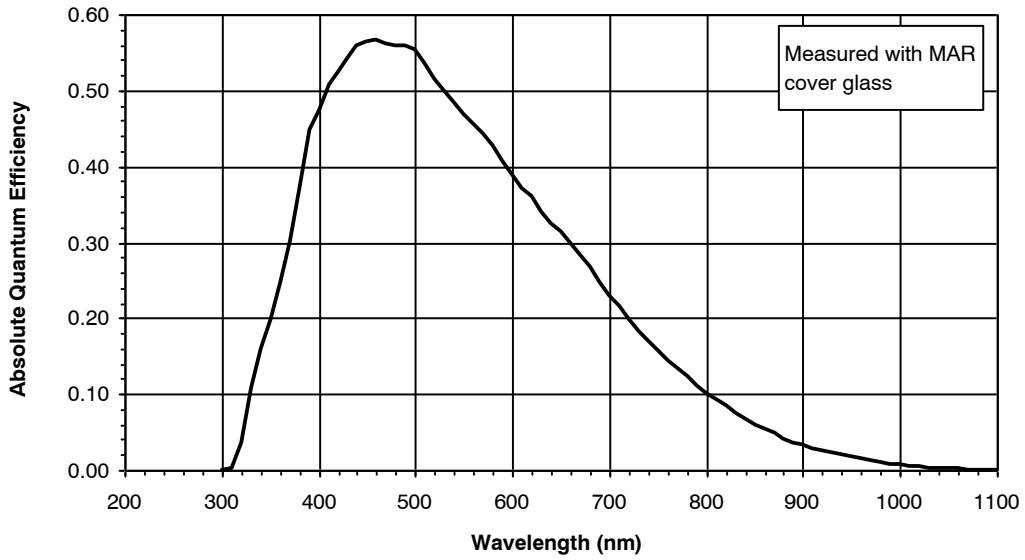

Figure 10. Monochrome with Microlens Quantum Efficiency

*Monochrome without Microlens*

Without coverglass

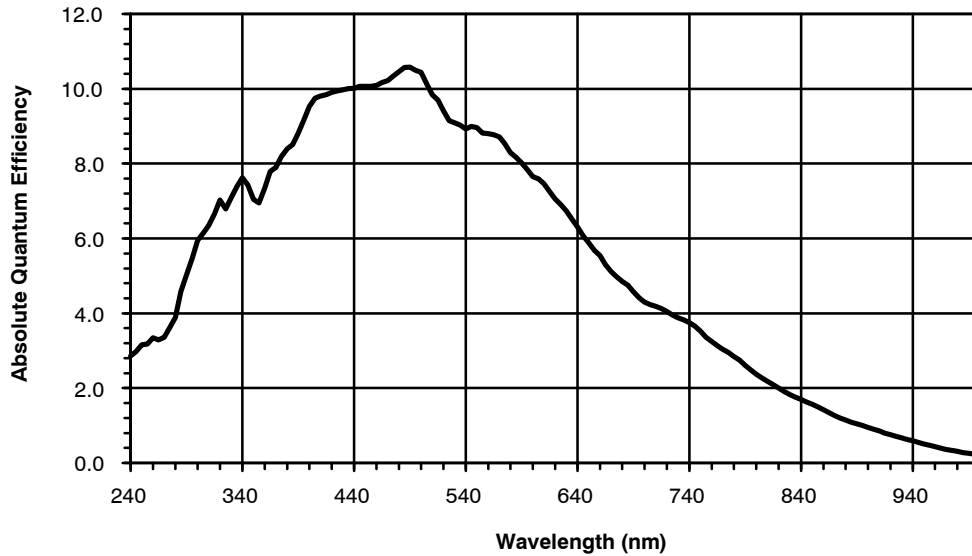

Figure 11. Monochrome without Microlens Quantum Efficiency

Color (Bayer RGB) with Microlens

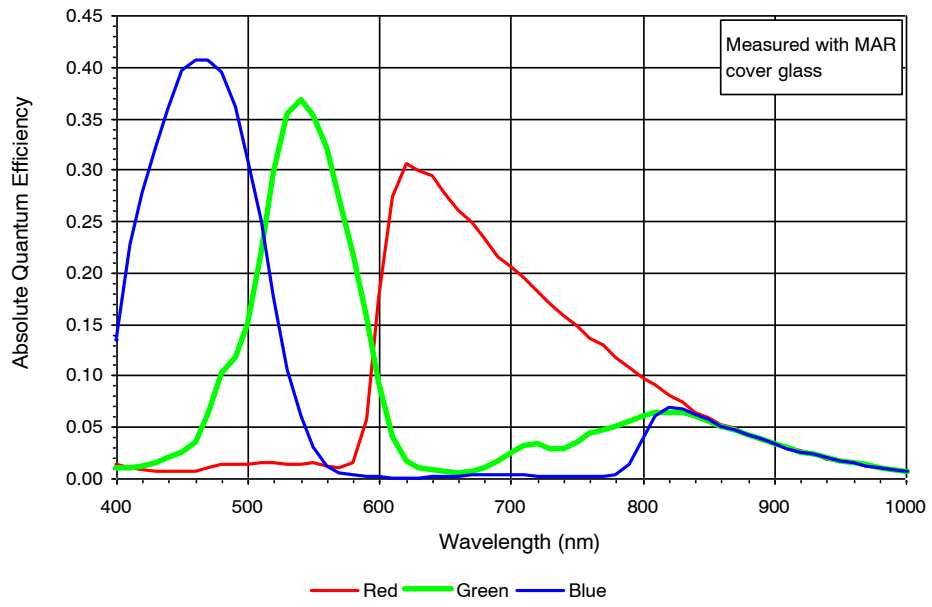

Figure 12. Color with Microlens Quantum Efficiency

**Angular Quantum Efficiency**

For the curves marked “Horizontal”, the incident light angle is varied in a plane parallel to the HCCD.  
 For the curves marked “Vertical”, the incident light angle is varied in a plane parallel to the VCCD.

*Monochrome with Microlens*

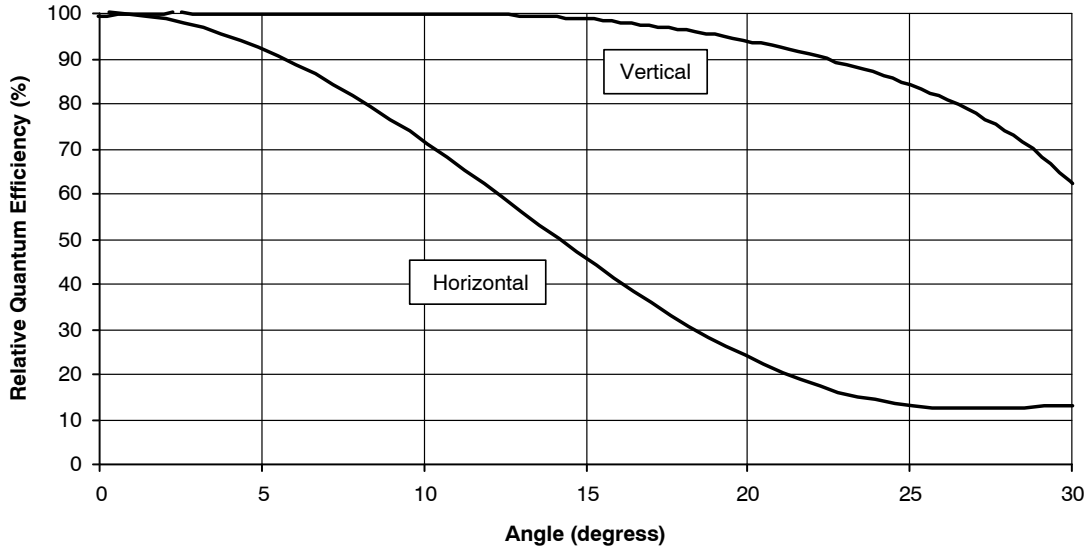

Figure 13. Angular Quantum Efficiency

**Dark Current vs. Temperature**

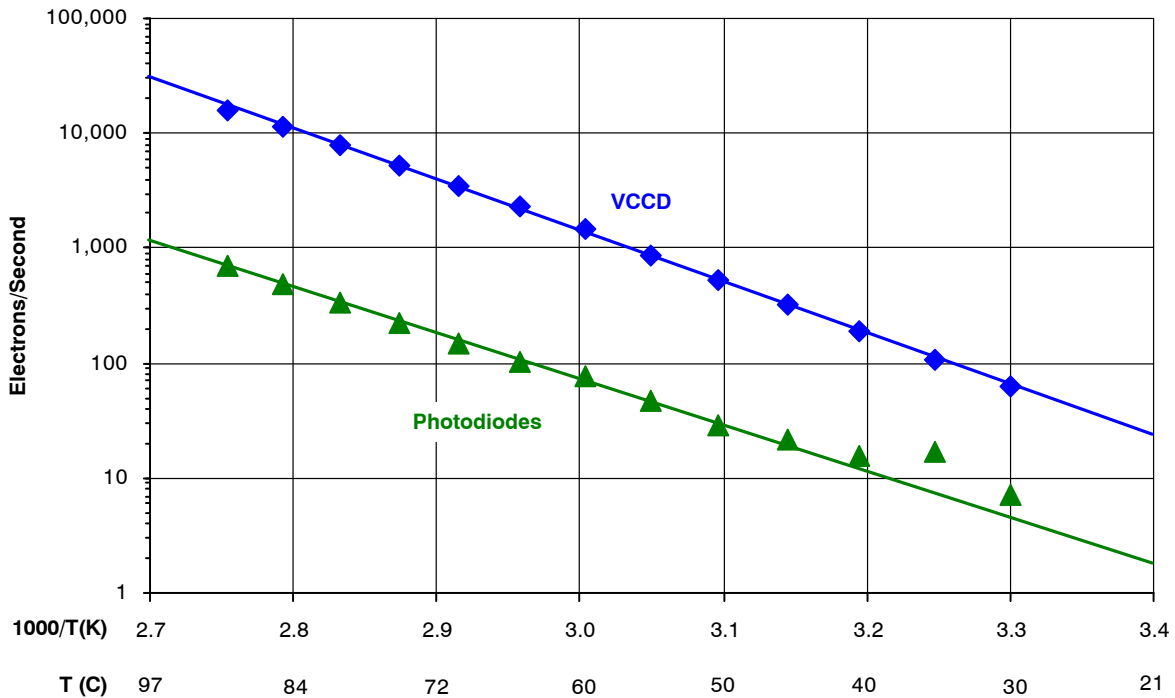

Figure 14. Dark Current vs. Temperature

Power-Estimated

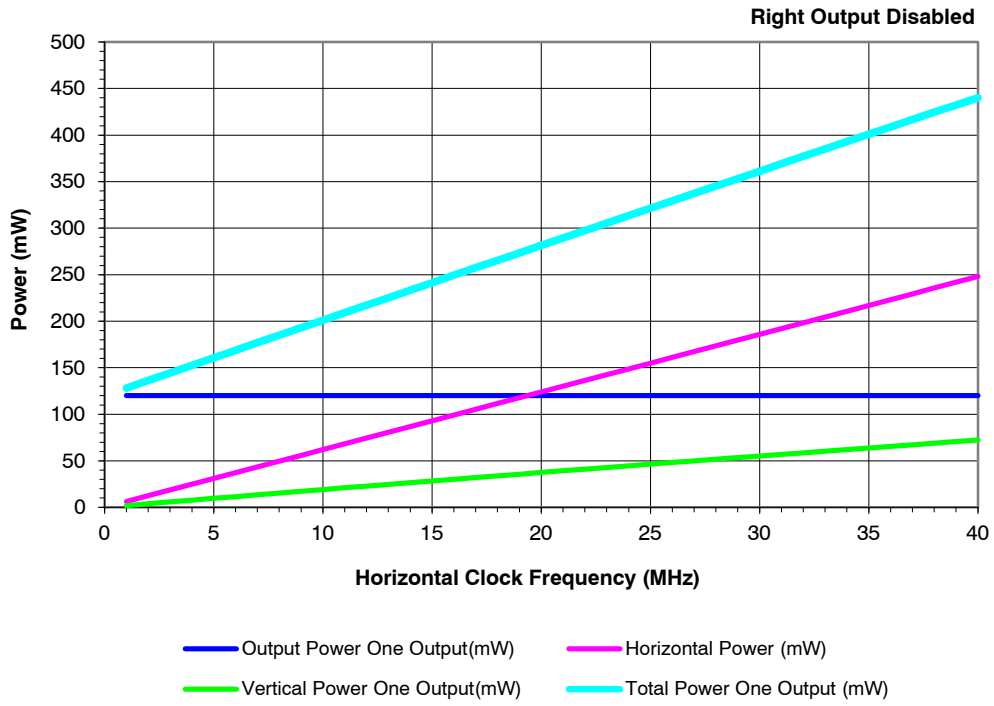

Figure 15. Power

Frame Rates

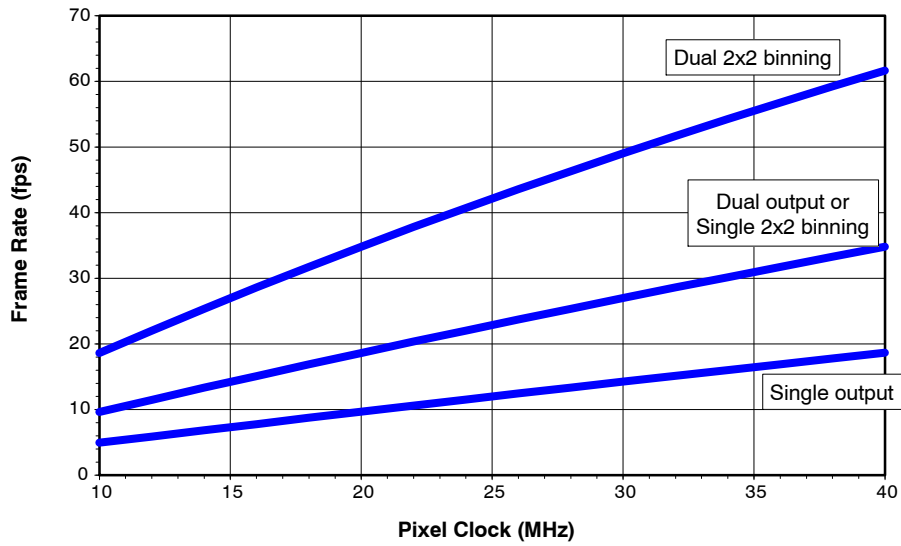

Figure 16. Frame Rates



## DEFECT DEFINITIONS

**Table 8. OPERATIONAL CONDITIONS**

Unless otherwise noted, the Defect Specifications are measured using the following conditions:

Description	Condition	Notes
Frame Time	237 msec	1
Horizontal Clock Frequency	10 MHz	
Light Source (LED)	Continuous red, green and blue illumination centered at 450, 530 and 650 nm	2, 3
Operation	Nominal operating voltages and timing	

1. Electronic shutter is not used. Integration time equals frame time.
2. LEDs used: Blue: Nichia NLPB500, Green: Nichia NSPG500S and Red: HP HLMP-8115.
3. For monochrome sensor, only green LED used.

**Table 9. SPECIFICATIONS**

Description	Definition	Maximum	Temperature(s) Tested at (°C)	Notes
Major Dark Field Defective Pixel	Defect $\geq$ 74 mV	20	27, 40	1
Major Bright Field Defective Pixel	Defect $\geq$ 10%			1
Minor Dark Field Defective Pixel	Defect $\geq$ 38 mV	200	27, 40	
Dead Pixel	Defect $\geq$ 80%	2	27, 40	1
Saturated Pixel	Defect $\geq$ 170 mV	5	27, 40	1
Cluster Defect	A group of 2 to 10 contiguous major defective pixels, but no more than 2 adjacent defects horizontally.	8	27, 40	1
Column Defect	A group of more than 10 contiguous major defective pixels along a single column.	0	27, 40	1

1. There will be at least two non-defective pixels separating any two major defective pixels.

**Defect Map**

The defect map supplied with each sensor is based upon testing at an ambient (27°C) temperature. Minor point

defects are not included in the defect map. All defective pixels are reference to pixel 1, 1 in the defect maps.

**TEST DEFINITIONS**

**Test Regions of Interest**

Active Area ROI: Pixel (1, 1) to Pixel (1600, 1200)  
 Center 100 by 100 ROI: Pixel (750, 550) to Pixel (849, 649)

**Overclocking**

The test system timing is configured such that the sensor is overclocked in both the vertical and horizontal directions. See Figure 17 for a pictorial representation of the regions.

Only the active pixels are used for performance and defect tests.

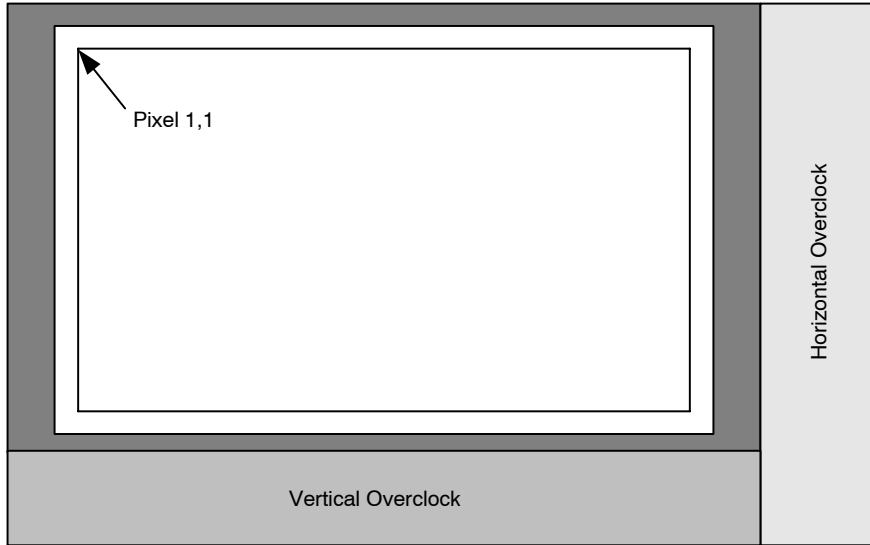

**Figure 17. Overclock Regions of Interest**

**Tests**

*Dark Field Center Non-Uniformity*

This test is performed under dark field conditions. Only the center 100 by 100 pixels of the sensor are used for this test – pixel (750, 550) to pixel (849, 649).

$$\text{Dark Field Center Uniformity} = \text{Standard Deviation of Center 100 by 100 Pixels in Electrons} \cdot \left( \frac{\text{DPS Integration Time}}{\text{Actual Integration Time Used}} \right)$$

Units: e<sup>-</sup> rms. DPS Integration Time: Device Performance Specification Integration Time = 33 ms.

*Dark Field Global Uniformity*

This test is performed under dark field conditions. The sensor is partitioned into 192 sub regions of interest, each of which is 100 by 100 pixels in size. See Figure 18. The average signal level of each of the 192 sub regions of interest is calculated. The signal level of each of the sub regions of interest is calculated using the following formula:

$$\begin{aligned} \text{Signal of ROI}[i] = & (\text{ROI Average in ADU} - \\ & - \text{Horizontal Overclock Average in ADU}) \cdot \\ & \cdot \text{mV per Count} \end{aligned}$$

Units : mVpp (millivolts Peak to Peak)

Where i = 1 to 192. During this calculation on the 192 sub regions of interest, the maximum and minimum signal levels are found. The dark field global uniformity is then calculated

as the maximum signal found minus the minimum signal level found.

*Global Uniformity*

This test is performed with the imager illumination to a level such that the output is at 80% of saturation (approximately 32,000 electrons). Prior to this test being performed the substrate voltage has been set such that the charge capacity of the sensor is 40,000 electrons. Global uniformity is defined as:

$$\text{Global Uniformity} = 100 \cdot \left( \frac{\text{Active Area Standard Deviation}}{\text{Active Area Signal}} \right)$$

Units : % rms

$$\begin{aligned} \text{Active Area Signal} = & \text{Active Area Average} - \\ & - \text{Horizontal Overclock Average} \end{aligned}$$

*Global Peak to Peak Non-Uniformity*

This test is performed with the imager illuminated to a level such that the output is at 80% of saturation (approximately 32,000 electrons). Prior to this test being performed the substrate voltage has been set such that the charge capacity of the sensor is 40,000 electrons. The sensor is partitioned into 192 sub regions of interest, each of which is 100 by 100 pixels in size. See Figure 18. The average signal level of each of the 192 sub regions of interest (ROI) is calculated. The signal level of each of the sub regions of interest is calculated using the following formula:

$$\text{Signal of ROI}[i] = (\text{ROI Average in ADU} - \text{Horizontal Overclock Average in ADU}) \cdot \text{mV per Count}$$

Where i = 1 to 192. During this calculation on the 192 sub regions of interest, the maximum and minimum signal levels are found. The global peak to peak uniformity is then calculated as:

$$\text{Global Uniformity} = \frac{\text{Max. Signal} - \text{Min. Signal}}{\text{Active Area Signal}}$$

Units : % pp

*Center Uniformity*

This test is performed with the imager illuminated to a level such that the output is at 80% of saturation (approximately 32,000 electrons). Prior to this test being performed the substrate voltage has been set such that the charge capacity of the sensor is 40,000 electrons. Defects are excluded for the calculation of this test. This test is performed on the center 100 by 100 pixels of the sensor (see Figure 18). Center uniformity is defined as:

$$\text{Center ROI Uniformity} = 100 \cdot \left( \frac{\text{Center ROI Standard Deviation}}{\text{Center ROI Signal}} \right)$$

Units : % rms

$$\text{Center ROI Signal} = \text{Center ROI Average} - \text{Horizontal Overclock Average}$$

*Dark Field Defect Test*

This test is performed under dark field conditions. The sensor is partitioned into 192 sub regions of interest, each of which is 100 by 100 pixels in size (see Figure 18). In each region of interest, the median value of all pixels is found. For each region of interest, a pixel is marked defective if it is greater than or equal to the median value of that region of interest plus the defect threshold specified in “Defect Definitions” section.

*Bright Field Defect Test*

This test is performed with the imager illuminated to a level such that the output is at 80% of saturation (approximately 32,000 electrons). Prior to this test being performed the substrate voltage has been set such that the charge capacity of the sensor is 40,000 electrons. The average signal level of all active pixels is found. The bright and dark thresholds are set as:

$$\text{Dark Defect Threshold} = \text{Active Area Signal} \cdot \text{Threshold}$$

$$\text{Bright Defect Threshold} = \text{Active Area Signal} \cdot \text{Threshold}$$

The sensor is then partitioned into 192 sub regions of interest, each of which is 100 by 100 pixels in size (see Figure 18). In each region of interest, the average value of all pixels is found. For each region of interest, a pixel is marked defective if it is greater than or equal to the median value of that region of interest plus the bright threshold specified or if it is less than or equal to the median value of that region of interest minus the dark threshold specified.

Example for major bright field defective pixels:

- Average value of all active pixels is found to be 960 mV (32,000 electrons).
- Dark defect threshold: 960 mV · 10% = 96 mV.
- Bright defect threshold: 960 mV · 10% = 96 mV.
- Region of interest #1 selected. This region of interest is pixels 1, 1 to pixels 100, 100.
  - ♦ Median of this region of interest is found to be 960 mV.
  - ♦ Any pixel in this region of interest that is ≥ (960 + 96 mV) 1056 mV in intensity will be marked defective.
  - ♦ Any pixel in this region of interest that is ≤ (960 – 96 mV) 864 mV in intensity will be marked defective.
- All remaining 191 sub regions of interest are analyzed for defective pixels in the same manner.

Test Sub Regions of Interest

Pixel  
(1,1)

1	2	3	4	5	6	7	8	9	10	11	12	13	14	15	16
17	18	19	20	21	22	23	24	25	26	27	28	29	30	31	32
33	34	35	36	37	38	39	40	41	42	43	44	45	46	47	48
49	50	51	52	53	54	55	56	57	58	59	60	61	62	63	64
65	66	67	68	69	70	71	72	73	74	75	76	77	78	79	80
81	82	83	84	85	86	87	88	89	90	91	92	93	94	95	96
97	98	99	100	101	102	103	104	105	106	107	108	109	110	111	112
113	114	115	116	117	118	119	120	121	122	123	124	125	126	127	128
129	130	131	132	133	134	135	136	137	138	139	140	141	142	143	144
145	146	147	148	149	150	151	152	153	154	155	156	157	158	159	160
161	162	163	164	165	166	167	168	169	170	171	172	173	174	175	176
177	178	179	180	181	182	183	184	185	186	187	188	189	190	191	192

Pixel  
(1600,1200)

Figure 18. Test Sub Regions of Interest

## OPERATION

Table 10. ABSOLUTE MAXIMUM RATINGS

Description	Symbol	Minimum	Maximum	Units	Notes
Temperature	T <sub>OP</sub>	-50	70	°C	1
Humidity	RH	5	90	%	2
Output Bias Current	I <sub>OUT</sub>	0.0	10	mA	3
Off-Chip Load	C <sub>L</sub>	-	10	pF	4

Stresses exceeding those listed in the Maximum Ratings table may damage the device. If any of these limits are exceeded, device functionality should not be assumed, damage may occur and reliability may be affected.

- Noise performance will degrade at higher temperatures.
- T = 25°C. Excessive humidity will degrade MTTF.
- Total for both outputs. Current is 5 mA for each output. Note that the current bias affects the amplifier bandwidth.
- With total output load capacitance of C<sub>L</sub> = 10 pF between the outputs and AC ground.

Table 11. MAXIMUM VOLTAGE RATINGS BETWEEN PINS

Description	Minimum	Maximum	Units	Notes
RL, RR, H1SL, H1SR, H2SL, H2SR, H1BL, H1BR, H2BL, H2BR, OGL, OGR to ESD	0	17	V	
Pin to Pin with ESD Protection	-17	17	V	1
VDDL, VDDR to GND	0	25	V	

- Pins with ESD protection are: RL, RR, H1SL, H1SR, H2SL, H2SR, H1BL, H2BL, H1BR, H2BR, OGL and OGR.

Table 12. DC BIAS OPERATING CONDITIONS (FOR &lt; 40,000 ELECTRONS)

Description	Symbol	Min.	Nom.	Max.	Units	Maximum DC Current	Notes
Output Gate	OG	-2.5	-2.0	-1.5	V	1 μA	4
Reset Drain	RD	11.5	12.0	12.5	V	1 μA	5
Output Amplifier Supply	V <sub>DD</sub>	14.5	15.0	15.5	V	1 mA	1
Ground	GND		0.0		V		
Substrate	SUB	8.0	V <sub>AB</sub>	17.0	V		3, 6
ESD Protection	ESD	-8.0	-7.0	-6.0	V		5
Output Amplifier Return	V <sub>SS</sub>	0.0	0.7	1.0	V		

- One output, unloaded.
- The operating value of the substrate voltage, V<sub>AB</sub>, will be marked on the shipping container for each device. The shipping container will be marked with two V<sub>AB</sub> voltages. One V<sub>AB</sub> will be for a 600 mV charge capacity (for operation of the horizontal clock frequencies greater than 20 MHz) and the other V<sub>AB</sub> will be for 1200 mV charge capacity (for horizontal clock frequencies at or below 20 MHz).
- V<sub>ESD</sub> must be at least 1 V more negative than H1L, H2L and RL during sensors operation AND during camera power turn on.
- Output gate voltage must be set to -3 V for 40,000 – 80,000 electrons output in summed interlaced or binning modes.
- Reset Drain voltage must be set to 13 V for 80,000 electrons output in summed interlaced or binning modes.
- Refer to Application Note *Using Interline CCD Image Sensors in High Intensity Visible Lighting Conditions*.

AC Operating Conditions

Table 13. CLOCK LEVELS

Description	Symbol	Min.	Nom.	Max.	Unit	Notes
Vertical CCD Clock High	V2H	7.5	8.0	8.5	V	
Vertical CCD Clocks Midlevel	V1M, V2M	-0.2	0.0	0.2	V	
Vertical CCD Clocks Low	V1L, V2L	-9.5	-9.0	-8.5	V	
Horizontal CCD Clocks Amplitude	H1H, H2H	4.5	5.0	5.5	V	
Horizontal CCD Clocks Low	H1L, H2L	-5.0	-4.0	-3.8	V	
Reset Clock Amplitude	RH	-	5.0	-	V	1
Reset Clock Low	RL	-4.0	-3.5	-3.0	V	
Electronic Shutter Voltage	V <sub>SHUTTER</sub>	44	48	52	V	2
Fast Dump High	FDH	4.8	5.0	5.2	V	
Fast Dump Low	FDL	-9.5	-9.0	-8.0	V	

1. Reset amplitude must be set to 7.0 V for 40,000 – 80,000 electrons output in summed interlaced or binning modes.
2. Refer to Application Note *Using Interline CCD Image Sensors in High Intensity Visible Lighting Conditions*.

Clock Line Capacitances

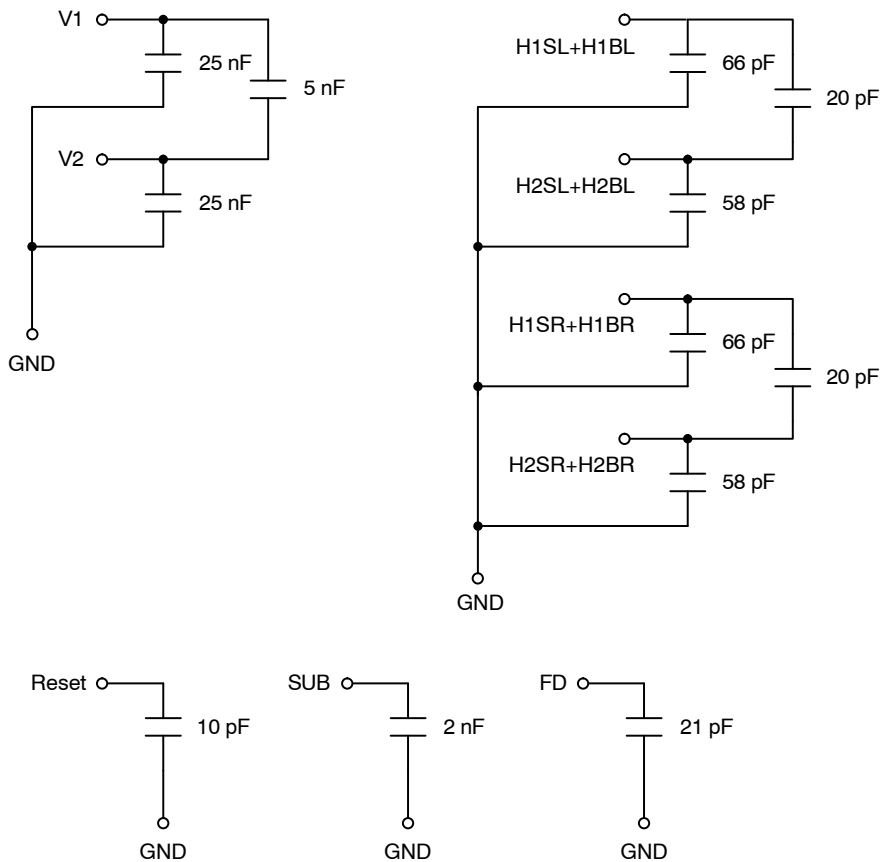

Figure 19. Clock Line Capacitances

**TIMING**

**Table 14. REQUIREMENTS AND CHARACTERISTICS**

Description	Symbol	Min.	Nom.	Max.	Unit
HCCD Delay	$t_{HD}$	1.3	1.5	10.0	$\mu s$
VCCD Transfer Time	$t_{VCCD}$	1.3	1.5	20.0	$\mu s$
Photodiode Transfer Time	$t_{V3rd}$	8.0	12.0	15.0	$\mu s$
VCCD Pedestal Time	$t_{3P}$	20.0	25.0	50.0	$\mu s$
VCCD Delay	$t_{3D}$	15.0	20.0	100.0	$\mu s$
Reset Pulse Time	$t_R$	5.0	10.0		ns
Shutter Pulse Time	$t_S$	3.0	5.0	10.0	$\mu s$
Shutter Pulse Delay	$t_{SD}$	1.0	1.6	10.0	$\mu s$
HCCD Clock Period	$t_H$	25.0	50.0	200.0	ns
VCCD Rise/Fall Time	$t_{VR}$	0.0	0.1	1.0	$\mu s$
Fast Dump Gate Delay	$t_{FD}$	0.0		0.5	$\mu s$
Vertical Clock Edge Alignment	$t_{VE}$	0.0		100.0	ns

**Timing Modes**

*Progressive Scan*

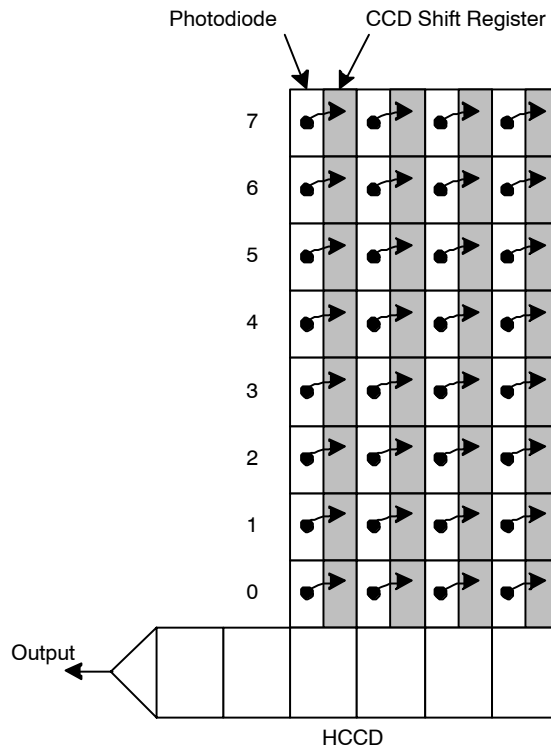

**Figure 20. Progressive Scan Operation**

In progressive scan read out every pixel in the image sensor is read out simultaneously. Each charge packet is transferred from the photodiode to the neighboring vertical

CCD shift register simultaneously. The maximum useful signal output is limited by the photodiode charge capacity to 40,000 electrons.

# KAI-2020

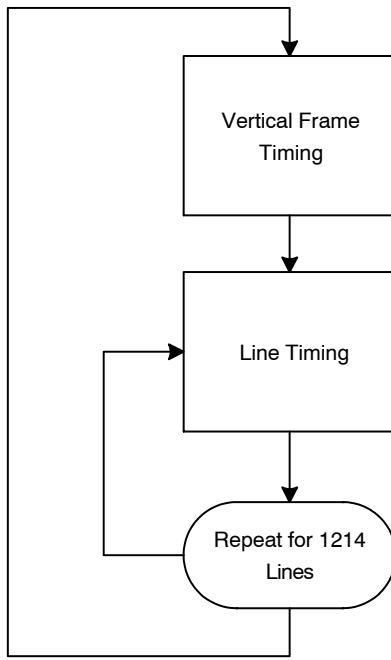
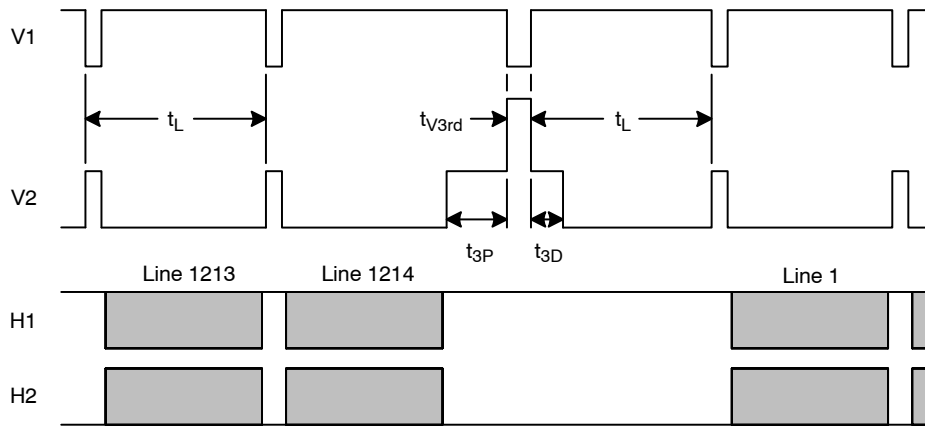

Figure 21. Progressive Scan Flow Chart



**Frame Timing**

*Frame Timing without Binning – Progressive Scan*



**Figure 22. Frame Timing without Binning**

*Frame Timing for Vertical Binning by 2 – Progressive Scan*

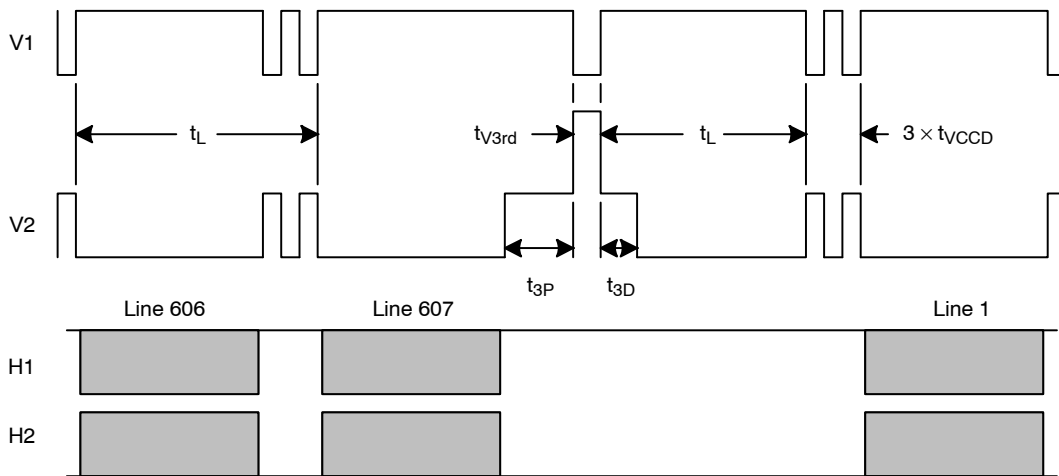

**Figure 23. Frame Timing for Vertical Binning by 2**

*Frame Timing Edge Alignment*

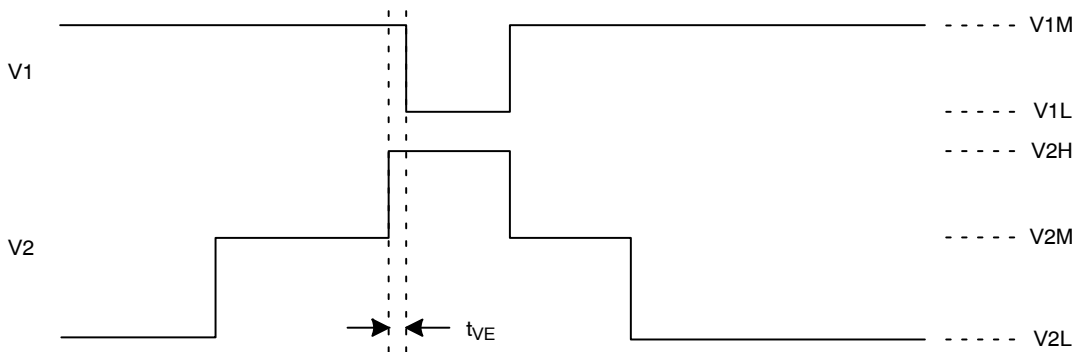

**Figure 24. Frame Timing Edge Alignment**

**Line Timing**

*Line Timing Single Output – Progressive Scan*

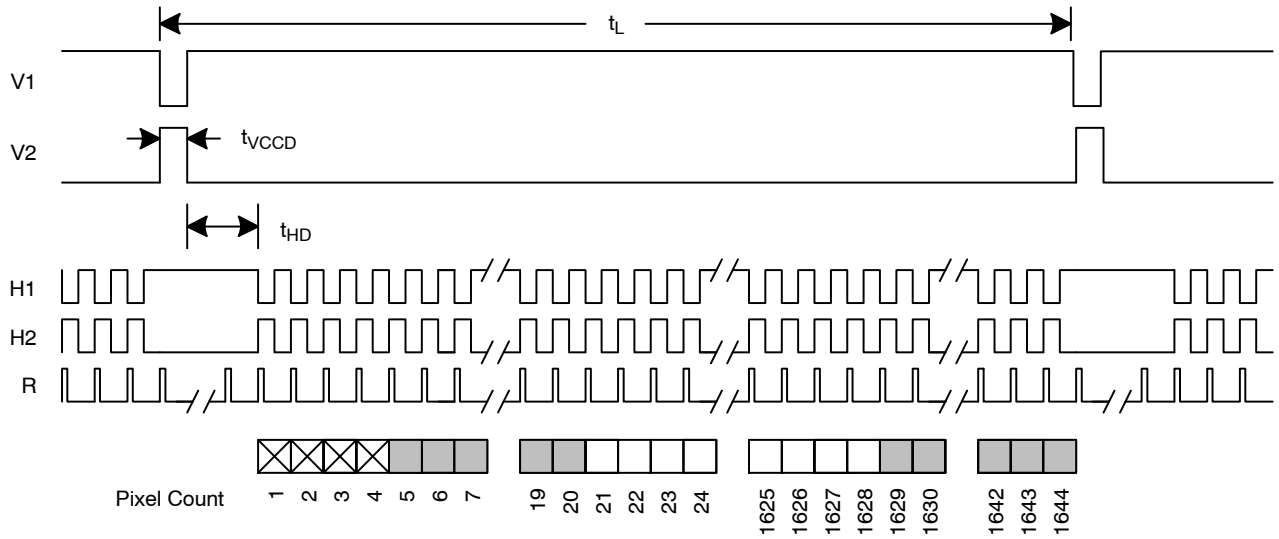

**Figure 25. Line Timing Single Output**

*Line Timing Dual Output – Progressive Scan*

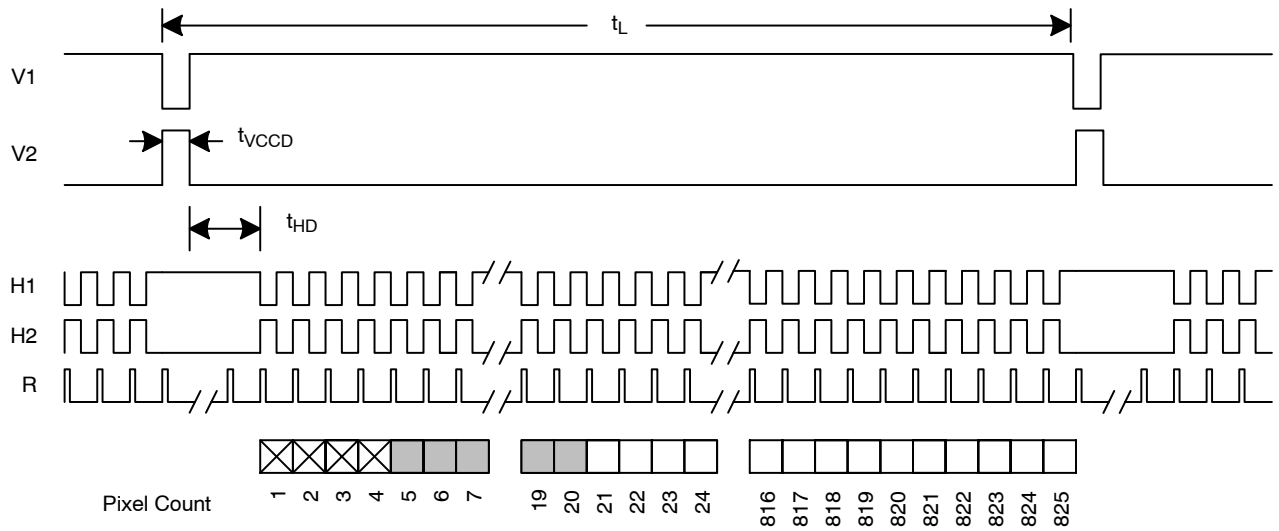

**Figure 26. Line Timing Dual Output**

Line Timing Vertical Binning by 2 – Progressive Scan

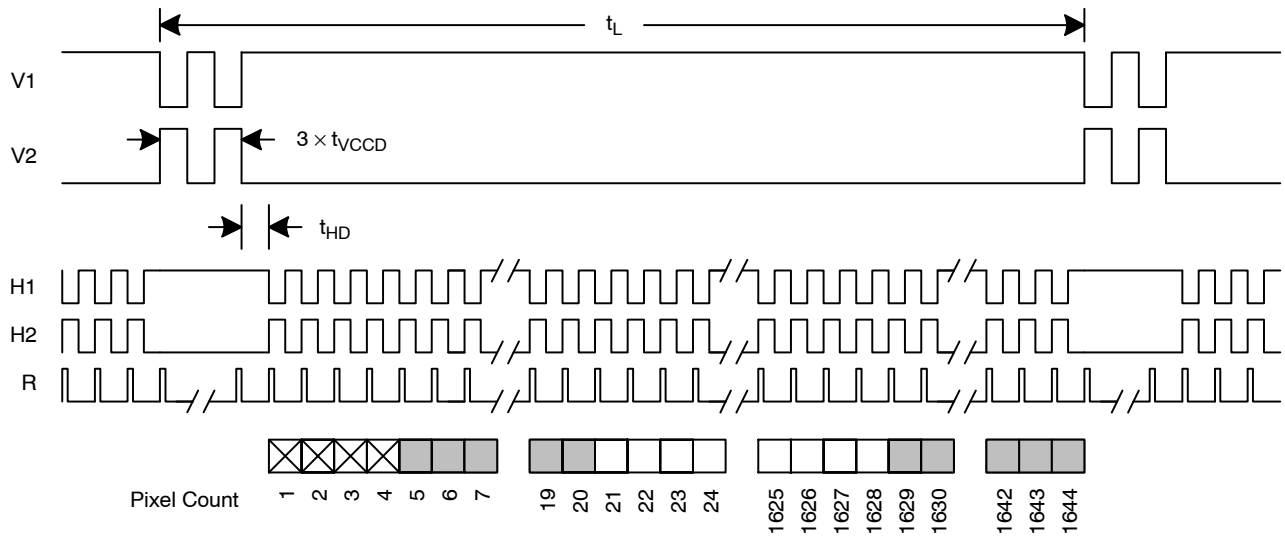

Figure 27. Line Timing Vertical Binning by 2

Line Timing Detail – Progressive Scan

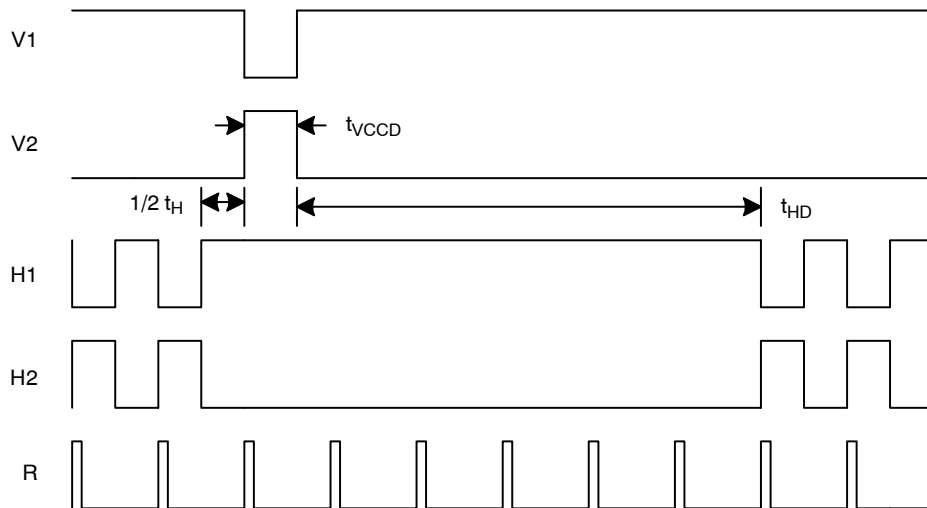
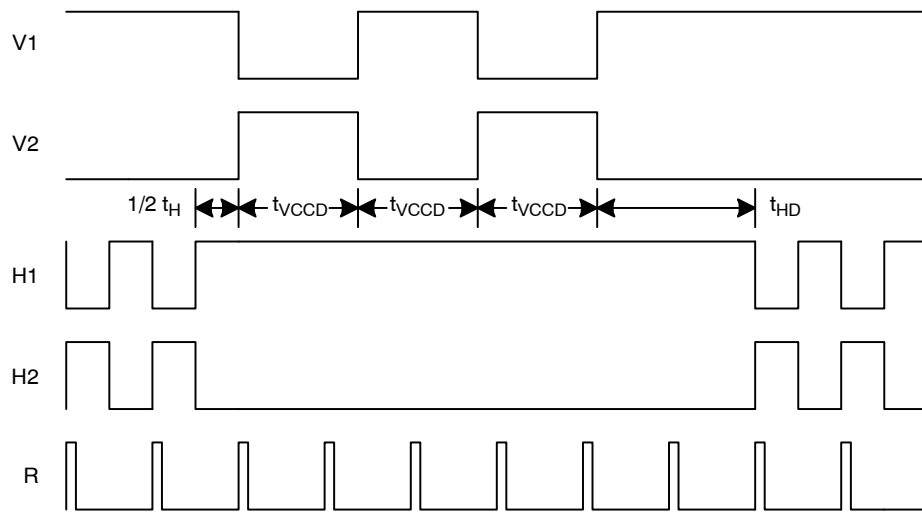

Figure 28. Line Timing Detail

*Line Timing Binning by 2 Detail – Progressive Scan*



**Figure 29. Line Timing by 2 Detail**

*Line Timing Edge Alignment*

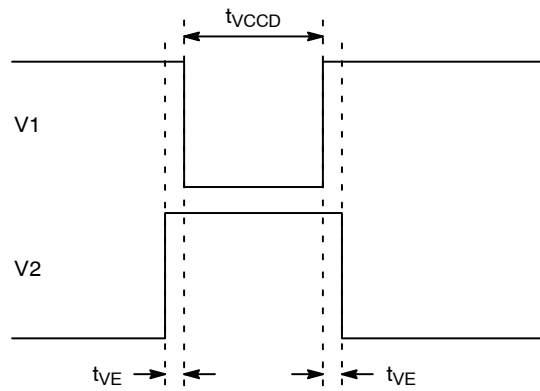

**Figure 30. Line Timing Edge Alignment**

**Pixel Timing**

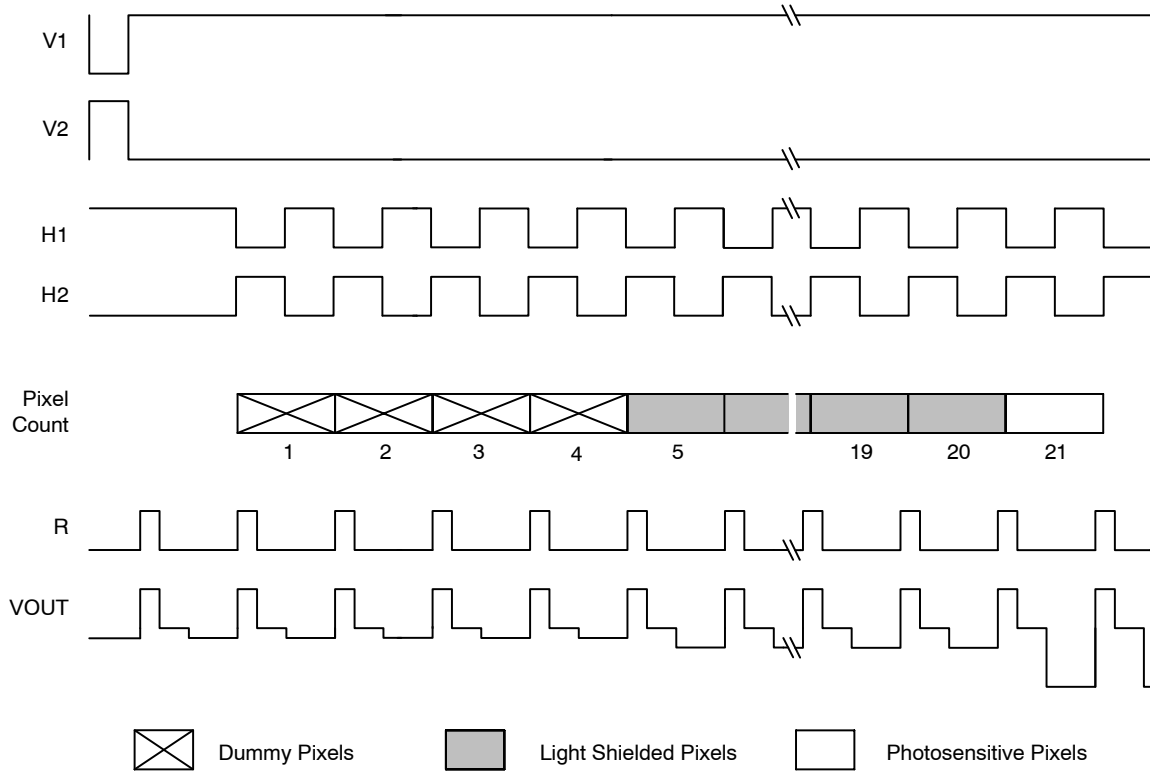

**Figure 31. Pixel Timing**

*Pixel Timing Detail*

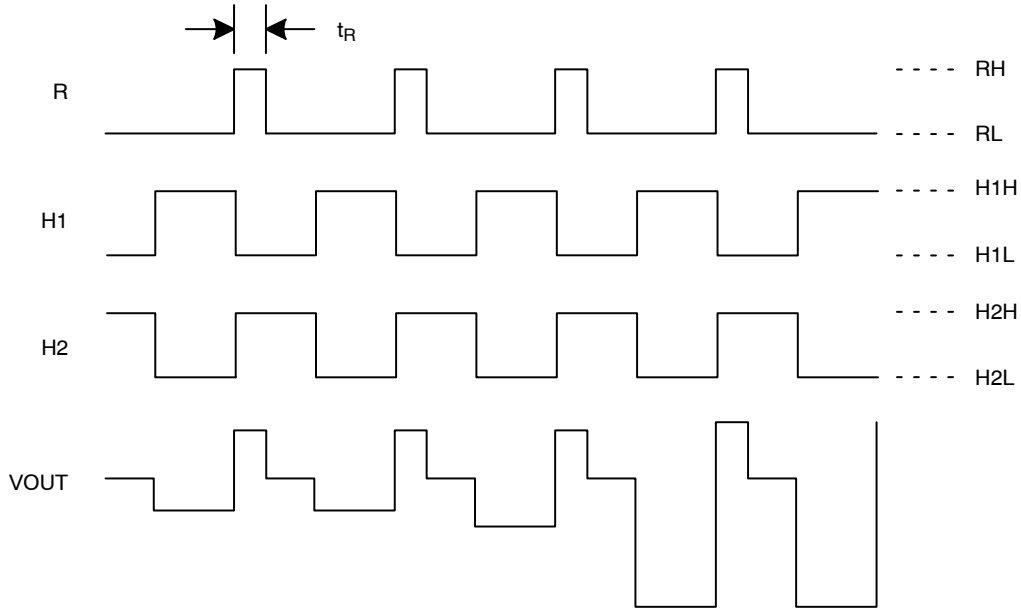

**Figure 32. Pixel Timing Detail**

Fast Line Dump Timing



Figure 33. Fast Line Dump Timing

**Electronic Shutter**

*Electronic Shutter Line Timing*



**Figure 34. Electronic Shutter Line Timing**

*Electronic Shutter – Integration Time Definition*



**Figure 35. Integration Time Definition**

*Electronic Shutter – DC and AC Bias Definition*

The figure below shows the DC bias ( $V_{SUB}$ ) and AC clock ( $V_{ES}$ ) applied to the SUB pin. Both the DC bias and AC clock are referenced to ground.

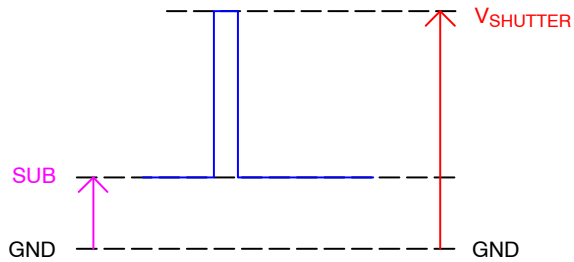

**Figure 36. DC Bias and AC Clock Applied to the SUB Pin**

*Electronic Shutter Description*

The voltage on the substrate (SUB) determines the charge capacity of the photodiodes. When SUB is 8 V the photodiodes will be at their maximum charge capacity. Increasing V<sub>SUB</sub> above 8 V decreases the charge capacity of the photodiodes until 48 V when the photodiodes have a charge capacity of zero electrons. Therefore, a short pulse on SUB, with a peak amplitude greater than 48 V, empties all photodiodes and provides the electronic shuttering action.

It may appear the optimal substrate voltage setting is 8 V to obtain the maximum charge capacity and dynamic range. While setting V<sub>SUB</sub> to 8 V will provide the maximum dynamic range, it will also provide the minimum anti-blooming protection.

The KAI-2020 VCCD has a charge capacity of 50,000 electrons (50 ke<sup>-</sup>). If the SUB voltage is set such that the photodiode holds more than 50 ke<sup>-</sup>, then when the charge is transferred from a full photodiode to VCCD, the VCCD will overflow. This overflow condition manifests itself in the image by making bright spots appear elongated in the vertical direction. The size increase of a bright spot is called blooming when the spot doubles in size. The blooming can be eliminated by increasing the voltage on SUB to lower the charge capacity of the photodiode. This ensures the VCCD charge capacity is greater than the photodiode capacity. There are cases where an extremely bright spot will still cause blooming in the VCCD. Normally, when the photodiode is full, any additional electrons generated by photons will spill out of the photodiode. The excess electrons are drained harmlessly out to the substrate. There is a maximum rate at which the electrons can be drained to the substrate. If that maximum rate is exceeded, (for example, by a very bright light source) then it is possible for the total amount of charge in the photodiode to exceed the VCCD capacity. This results in blooming. The amount of anti-blooming protection also decreases when the integration time is decreased. There is a compromise between photodiode dynamic range (controlled by V<sub>SUB</sub>) and the amount of anti-blooming protection. A low V<sub>SUB</sub> voltage provides the maximum dynamic range and minimum (or no) anti-blooming protection. A high V<sub>SUB</sub> voltage provides lower dynamic range and maximum anti-blooming protection. The optimal setting of V<sub>SUB</sub> is written on the container in which each KAI-2020 is shipped. The given V<sub>SUB</sub> voltage for each sensor is selected to provide anti-blooming protection for bright spots at least 100 times saturation, while maintaining at least 40 ke<sup>-</sup> of dynamic range.

The electronic shutter provides a method of precisely controlling the image exposure time without any mechanical components. If an integration time of  $t_{INT}$  is desired, then the substrate voltage of the sensor is pulsed to at least 40 V  $t_{INT}$  seconds before the photodiode to VCCD transfer pulse on V<sub>2</sub>. Use of the electronic shutter does not have to wait until the previously acquired image has been completely read out of the VCCD.

**Large Signal Output**

When the image sensor is operated in the binned or summed interlaced modes there will be more than 20,000 electrons in the output signal. The image sensor is designed with a 30  $\mu\text{V}/e$  charge to voltage conversion on the output. This means a full signal of 40,000 electrons will produce a 600 mV change on the output amplifier. The output amplifier was designed to handle an output swing of 600 mV at a pixel rate of 40 MHz. If 40,000 electron charge packets are generated in the binned or summed interlaced modes then the output amplifier output will have to swing 1,200 mV. The output amplifier does not have enough bandwidth (slew rate) to handle 1,200 mV at 40 MHz. Hence, the pixel rate will have to be reduced to 20 MHz if the full dynamic range of 40,000 electrons is desired.

The charge handling capacity of the output amplifier is also set by the reset clock voltage levels. The reset clock driver circuit is very simple if an amplitude of 5 V is used. But the 5 V amplitude restricts the output amplifier charge capacity to 20,000 electrons. If the full dynamic range of 40,000 electrons is desired then the reset clock amplitude will have to be increased to 7 V.

If you only want a maximum signal of 20,000 electrons in binned or summed interlaced modes, then a 40 MHz pixel rate with a 5 V reset clock may be used. The output of the amplifier will be unpredictable above 20,000 electrons so be sure to set the maximum input signal level of your analog to digital converter to the equivalent of 20,000 electrons (600 mV).



## STORAGE AND HANDLING

Table 15. STORAGE CONDITIONS

Description	Symbol	Minimum	Maximum	Unit	Notes
Storage Temperature	T <sub>ST</sub>	-55	80	°C	1
Humidity	RH	5	90	%	2

1. Long-term exposure toward the maximum temperature will accelerate color filter degradation.
2. T = 25°C. Excessive humidity will degrade MTTF.

For information on ESD and cover glass care and cleanliness, please download the *Image Sensor Handling and Best Practices* Application Note (AN52561/D) from [www.onsemi.com](http://www.onsemi.com).

For information on environmental exposure, please download the *Using Interline CCD Image Sensors in High Intensity Lighting Conditions* Application Note (AND9183/D) from [www.onsemi.com](http://www.onsemi.com).

For information on soldering recommendations, please download the *Soldering and Mounting Techniques Reference Manual* (SOLDERRM/D) from [www.onsemi.com](http://www.onsemi.com).

For quality and reliability information, please download the *Quality & Reliability Handbook* (HBD851/D) from [www.onsemi.com](http://www.onsemi.com).

For information on device numbering and ordering codes, please download the *Device Nomenclature* technical note (TND310/D) from [www.onsemi.com](http://www.onsemi.com).

For information on Standard terms and Conditions of Sale, please download [Terms and Conditions](http://www.onsemi.com) from [www.onsemi.com](http://www.onsemi.com).

MECHANICAL DRAWINGS

Completed Assembly

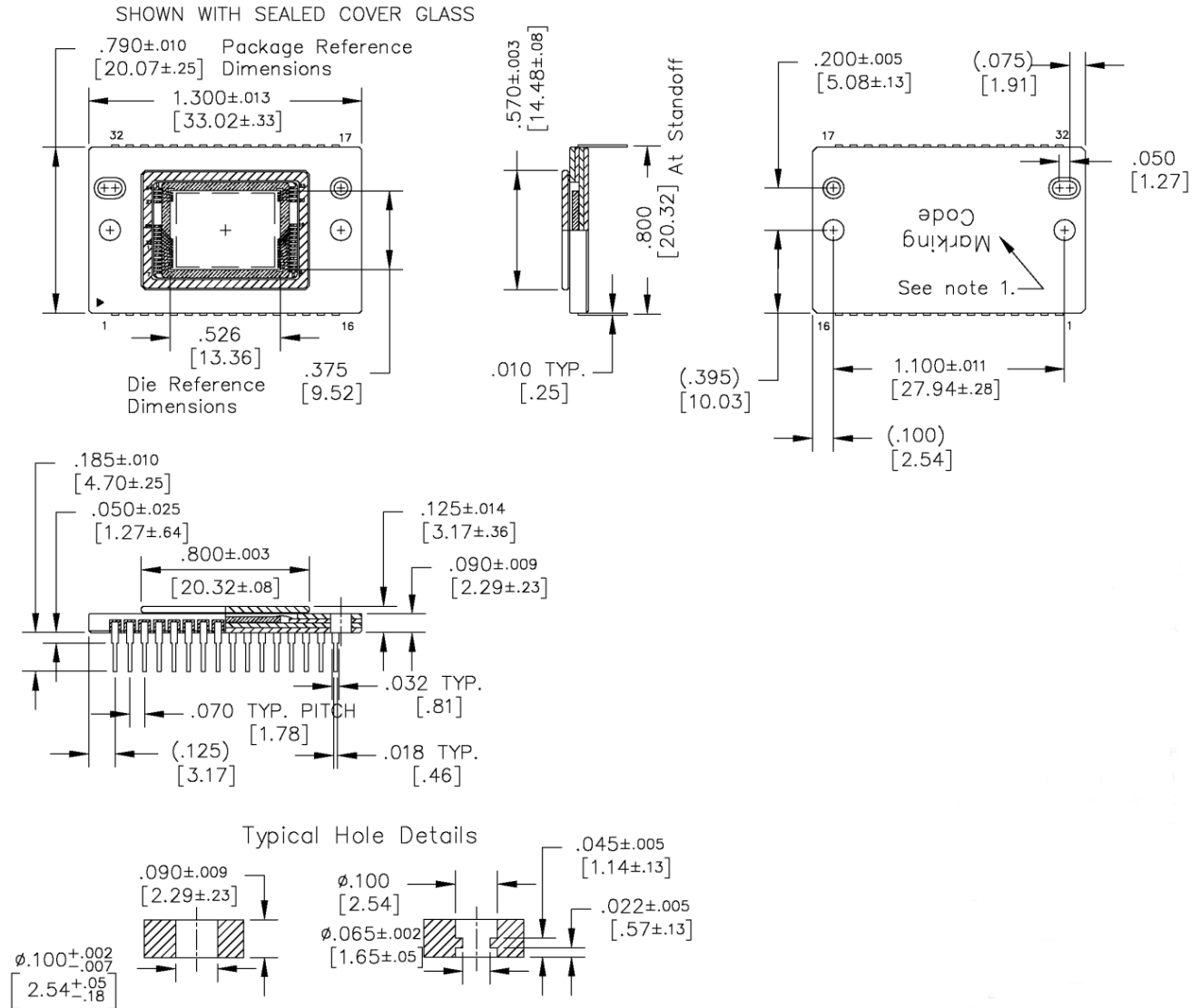

Notes:

1. See Ordering Table for marking code.
2. Cover glass is manually placed and visually aligned over die – Location accuracy is not guaranteed.

Dimensions Units: IN [MM]

Tolerances: Unless otherwise specified

Ceramic  $\pm 1\%$  no less than 0.005"

L/F  $\pm 1\%$  no more than 0.005"

Figure 37. Completed Assembly (1 of 2)

# KAI-2020

SHOWN WITHOUT COVER GLASS



SHOWN WITH SEALED COVER GLASS



**Notes:**

1. See Ordering Table for marking code.
2. Cover glass is manually placed and visually aligned over die – Location accuracy is not guaranteed.

Dimensions Units: IN [MM]

Tolerances: Unless otherwise specified

Ceramic ±1% no less than 0.005"

L/F ±1% no more than 0.005"

**Figure 38. Completed Assembly (2 of 2)**

Cover Glass

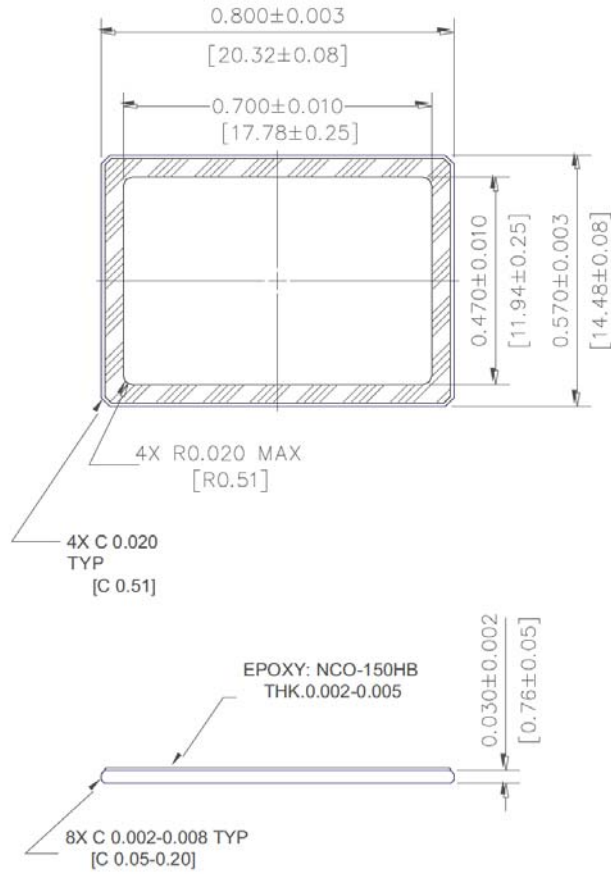

Notes:

1. Materials: Substrate – Schott D236T eco or equivalent  
Epoxy: NCO-150HB  
Thickness: 0.002”-0.005”
2. Dust, Scratch Count – 10 microns max.
3. Double Sided AR Coating Reflectance:  
420-435 nm < 2%  
435-630 nm < 0.8%  
630-680 nm < 2%

Units: IN [MM]

Tolerance: Unless otherwise specified  
±1% no less than 0.005”

Figure 39. Glass Drawing

Glass Transmission

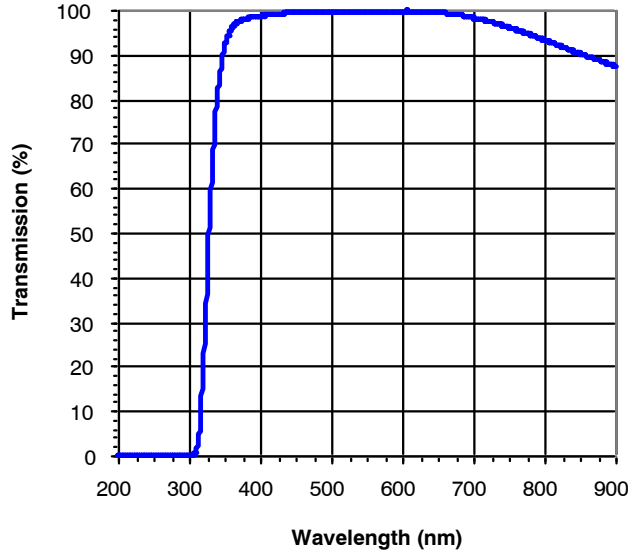

Figure 40. MAR Glass Transmission

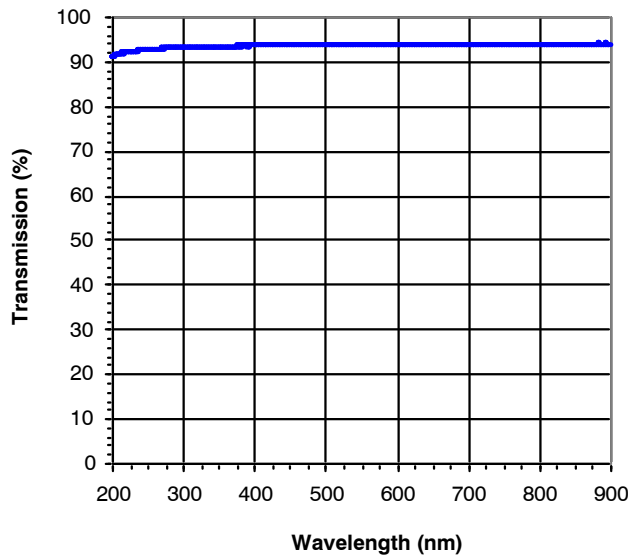



Figure 41. Quartz Glass Transmission

ON Semiconductor and the  are registered trademarks of Semiconductor Components Industries, LLC (SCILLC) or its subsidiaries in the United States and/or other countries. SCILLC owns the rights to a number of patents, trademarks, copyrights, trade secrets, and other intellectual property. A listing of SCILLC's product/patent coverage may be accessed at [www.onsemi.com/site/pdf/Patent-Marking.pdf](http://www.onsemi.com/site/pdf/Patent-Marking.pdf). SCILLC reserves the right to make changes without further notice to any products herein. SCILLC makes no warranty, representation or guarantee regarding the suitability of its products for any particular purpose, nor does SCILLC assume any liability arising out of the application or use of any product or circuit, and specifically disclaims any and all liability, including without limitation special, consequential or incidental damages. "Typical" parameters which may be provided in SCILLC data sheets and/or specifications can and do vary in different applications and actual performance may vary over time. All operating parameters, including "Typicals" must be validated for each customer application by customer's technical experts. SCILLC does not convey any license under its patent rights nor the rights of others. SCILLC products are not designed, intended, or authorized for use as components in systems intended for surgical implant into the body, or other applications intended to support or sustain life, or for any other application in which the failure of the SCILLC product could create a situation where personal injury or death may occur. Should Buyer purchase or use SCILLC products for any such unintended or unauthorized application, Buyer shall indemnify and hold SCILLC and its officers, employees, subsidiaries, affiliates, and distributors harmless against all claims, costs, damages, and expenses, and reasonable attorney fees arising out of, directly or indirectly, any claim of personal injury or death associated with such unintended or unauthorized use, even if such claim alleges that SCILLC was negligent regarding the design or manufacture of the part. SCILLC is an Equal Opportunity/Affirmative Action Employer. This literature is subject to all applicable copyright laws and is not for resale in any manner.

PUBLICATION ORDERING INFORMATION

**LITERATURE FULFILLMENT:**  
 Literature Distribution Center for ON Semiconductor  
 P.O. Box 5163, Denver, Colorado 80217 USA  
**Phone:** 303-675-2175 or 800-344-3860 Toll Free USA/Canada  
**Fax:** 303-675-2176 or 800-344-3867 Toll Free USA/Canada  
**Email:** [orderlit@onsemi.com](mailto:orderlit@onsemi.com)

**N. American Technical Support:** 800-282-9855 Toll Free  
 USA/Canada  
**Europe, Middle East and Africa Technical Support:**  
 Phone: 421 33 790 2910  
**Japan Customer Focus Center**  
 Phone: 81-3-5817-1050

**ON Semiconductor Website:** [www.onsemi.com](http://www.onsemi.com)  
**Order Literature:** <http://www.onsemi.com/orderlit>  
 For additional information, please contact your local  
 Sales Representative



Компания «ЭлектроПласт» предлагает заключение долгосрочных отношений при поставках импортных электронных компонентов на взаимовыгодных условиях!

Наши преимущества:

- Оперативные поставки широкого спектра электронных компонентов отечественного и импортного производства напрямую от производителей и с крупнейших мировых складов;
- Поставка более 17-ти миллионов наименований электронных компонентов;
- Поставка сложных, дефицитных, либо снятых с производства позиций;
- Оперативные сроки поставки под заказ (от 5 рабочих дней);
- Экспресс доставка в любую точку России;
- Техническая поддержка проекта, помощь в подборе аналогов, поставка прототипов;
- Система менеджмента качества сертифицирована по Международному стандарту ISO 9001;
- Лицензия ФСБ на осуществление работ с использованием сведений, составляющих государственную тайну;
- Поставка специализированных компонентов (Xilinx, Altera, Analog Devices, Intersil, Interpoint, Microsemi, Aeroflex, Peregrine, Syfer, Eurofarad, Texas Instrument, Miteq, Cobham, E2V, MA-COM, Hittite, Mini-Circuits, General Dynamics и др.);

Помимо этого, одним из направлений компании «ЭлектроПласт» является направление «Источники питания». Мы предлагаем Вам помощь Конструкторского отдела:

- Подбор оптимального решения, техническое обоснование при выборе компонента;
- Подбор аналогов;
- Консультации по применению компонента;
- Поставка образцов и прототипов;
- Техническая поддержка проекта;
- Защита от снятия компонента с производства.



#### Как с нами связаться

**Телефон:** 8 (812) 309 58 32 (многоканальный)

**Факс:** 8 (812) 320-02-42

**Электронная почта:** [org@eplast1.ru](mailto:org@eplast1.ru)

**Адрес:** 198099, г. Санкт-Петербург, ул. Калинина, дом 2, корпус 4, литера А.