



MAX4213 Evaluation Kit

Evaluates: MAX4213/MAX4215

General Description

The MAX4213 evaluation kit (EV kit) simplifies evaluation of the MAX4213 high-speed, single-supply amplifier with Rail-to-Rail® outputs. The EV kit circuit demonstrates the MAX4213 in the noninverting unity-gain configuration, in either single or dual-supply mode.

This EV kit may also be used to evaluate the MAX4215 high-speed, rail-to-rail buffer. Contact Maxim to order a free sample.

Component List

DESIGNATION	QTY	DESCRIPTION
U1	1	MAX4213ESA
C1, C2	2	0.1 μ F, 10% ceramic capacitors
C3, C4	2	10 μ F, 10V, 20% tantalum capacitors AVX TAJB106M010 or Sprague 293D106X0010B
R1, R2	2	49.9 Ω , 1% resistors
R3	0	Short (PC trace)
R _F	1	24 Ω , 5% resistor
R _G	0	Open
IN, OUT	2	SMA connectors
None	1	MAX4213 EV kit PC board
None	1	MAX4213 data sheet

Component Suppliers

SUPPLIER*	PHONE	FAX
AVX	(803) 946-0690	(803) 626-3123
Sprague	(603) 224-1961	(603) 224-1430

*Please indicate that you are using the MAX4213 when contacting these component suppliers.

Rail-to-Rail is a registered trademark of Nippon Motorola Ltd.

Features

- ◆ 300MHz -3dB Bandwidth
- ◆ 600V/ μ s Slew Rate
- ◆ Single 3.3V/5V Operation
- ◆ Rail-to-Rail Outputs
- ◆ Fully Assembled and Tested

Ordering Information

PART	TEMP. RANGE	BOARD TYPE
MAX4213EVKIT-SO	-40°C to +85°C	Surface Mount

Note: To evaluate the MAX4215, request a MAX4215ESA free sample.

Quick Start

The MAX4213 EV kit is fully assembled and tested. Follow these steps to verify board operation. **Do not turn on the power supply until all connections are completed.**

- 1) For single-supply operation, connect a +5V power supply to the pad marked VCC. Connect the power-supply ground to the VEE and GND pads.
- 2) Verify that a shunt is across pins 1 and 2 of JU1.
- 3) Connect the output marked OUT to an oscilloscope input.
- 4) Turn on the power supply. Apply a +0.5V to +2.75V signal to the SMA connector marked IN.
- 5) Verify the output signal on the oscilloscope.

Note: If you use a 50 Ω terminated oscilloscope input, the output amplitude observed will be half that of the input, due to the voltage divider formed by the 49.9 Ω back-terminating resistor (R1) and the oscilloscope input termination.



Maxim Integrated Products 1

**For free samples & the latest literature: <http://www.maxim-ic.com>, or phone 1-800-998-8800.
For small orders, phone 1-800-835-8769.**

MAX4213 Evaluation Kit

Detailed Description

Supply Voltage

The MAX4213 EV kit can be used in either single or dual-supply mode. Negative power-supply filter capacitors C1 and C3 can be eliminated in your final single-supply design.

Enable Control

The MAX4213 provides an enable pin (EN) to enable or disable the output. Table 1 lists the options available for the enable/disable control jumper JU1. You can use an external controller by removing the shunt on JU1 completely and connecting the external controller to the pad labeled EN. EN is a TTL/CMOS logic-level input.

Table 1. Jumper JU1 Functions

SHUNT LOCATION	ENABLE PIN	MAX4213 OUTPUT
1 and 2	Connected to V _{CC}	Enabled
2 and 3	Connected to GND	Disabled

Enable Logic-Low Input Current

Under certain conditions, the logic-low input current can increase. The MAX4213 EV kit provides a resistor location (R3) to limit the logic-low input current. A 10k Ω resistor value is recommended. R3 is normally shorted by a PC board trace between its pads. Be sure to cut this shorting trace before installing a resistor. Refer to the *Enable Input and Disabled Output* section of the MAX4212/MAX4213/MAX4216/MAX4218/MAX4220 data sheet for further details.

Layout Considerations

The MAX4213 EV kit layout has been optimized for high-speed signals and low distortion, with careful attention given to grounding, power-supply bypassing, and signal-path layout. The small, surface-mount, ceramic bypass capacitors C1 and C2 have been placed as close to the MAX4213 supply pins as possible. The ground plane has been removed around and under the MAX4213 to reduce stray capacitance. Capacitance at the inverting input pin has been minimized by reducing the length and width of the input and feedback traces, and by using 0805-size surface-mount feedback and gain-set resistors.

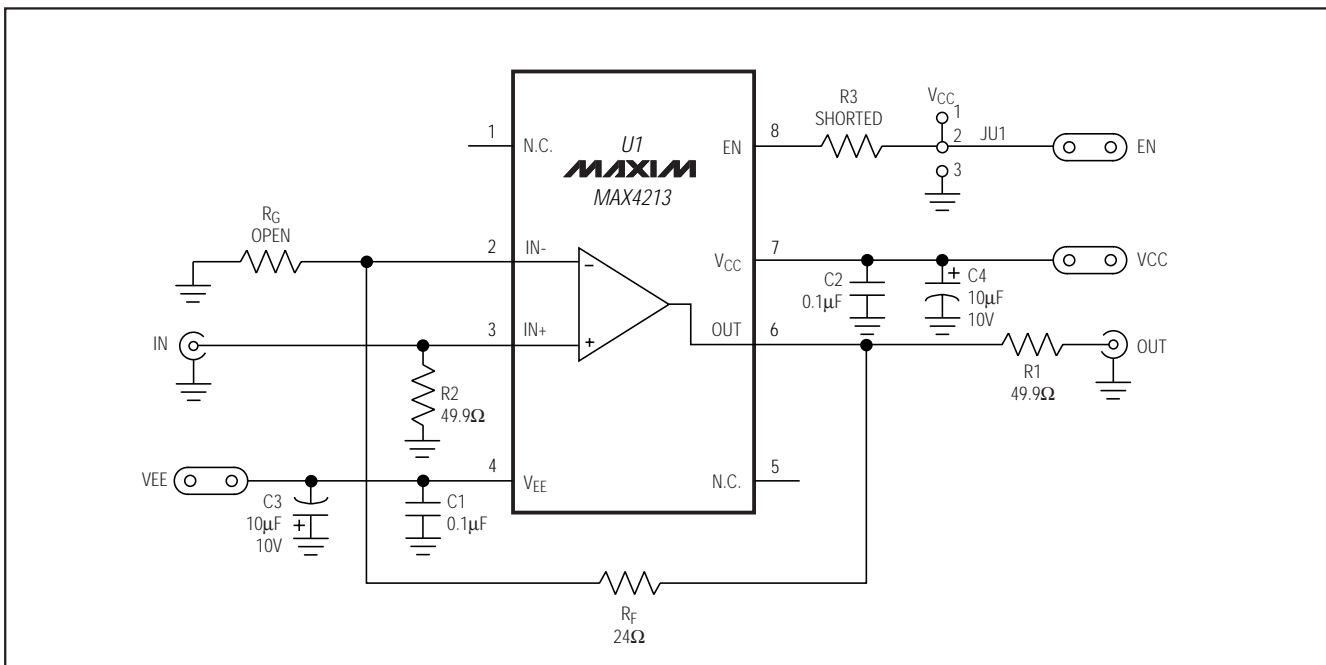

Figure 1. MAX4213 EV Kit Schematic

MAX4213 Evaluation Kit

Evaluates: MAX4213/MAX4215

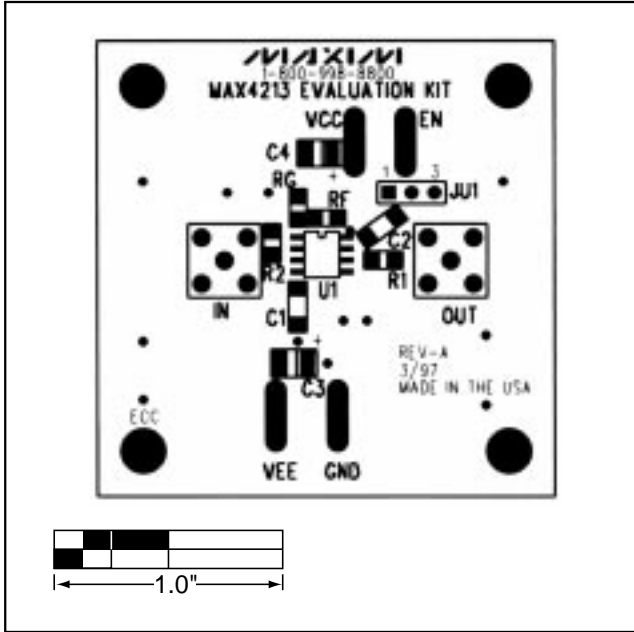

Figure 2. MAX4213 EV Kit Component Placement Guide—Component Side

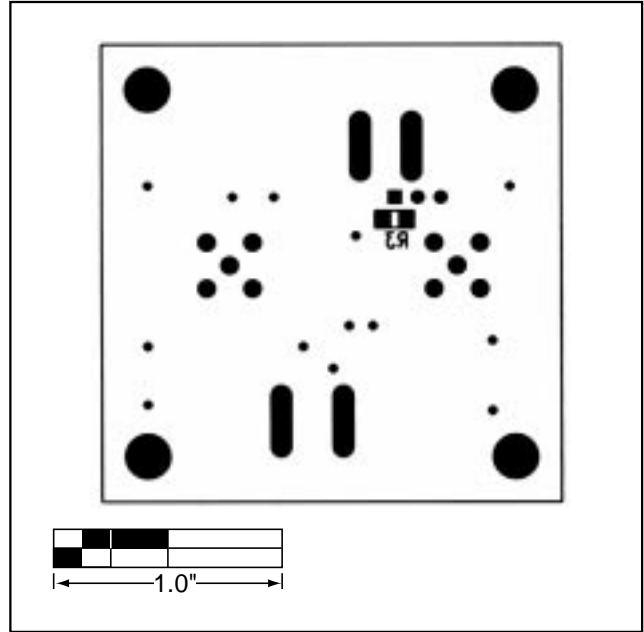

Figure 3. MAX4213 EV Kit Component Placement Guide—Solder Side

MAX4213 Evaluation Kit

Evaluates: MAX4213/MAX4215

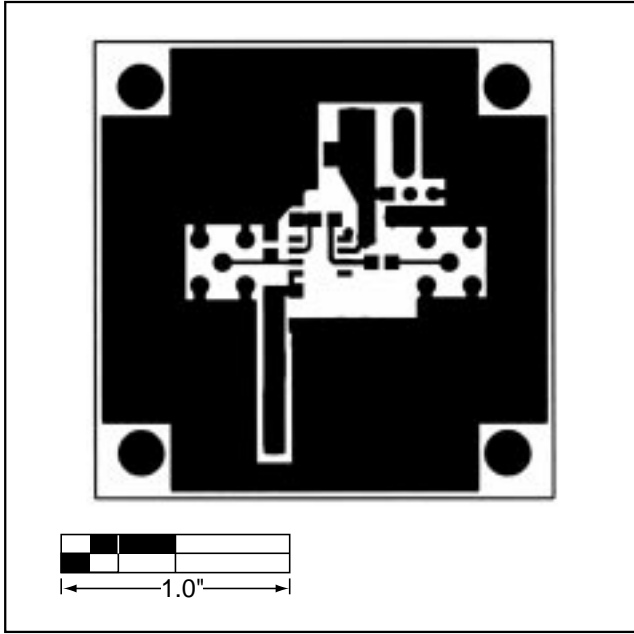

Figure 4. MAX4213 EV Kit PC Board Layout—Component Side

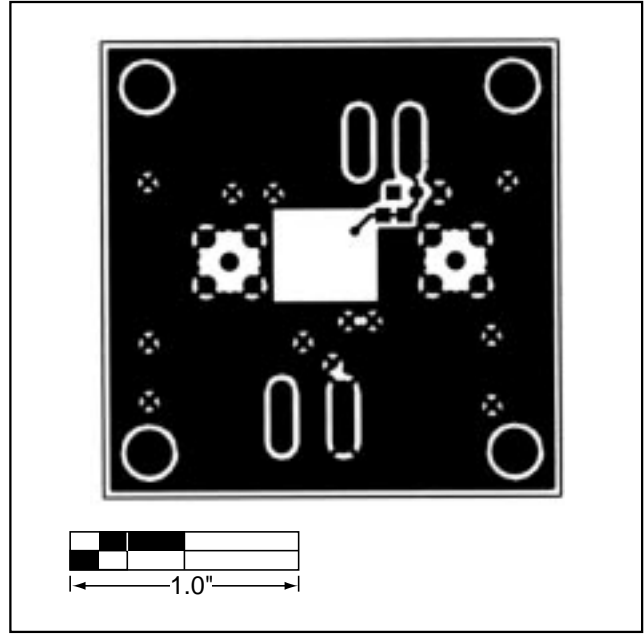

Figure 5. MAX4213 EV Kit PC Board Layout—Solder Side

Maxim cannot assume responsibility for use of any circuitry other than circuitry entirely embodied in a Maxim product. No circuit patent licenses are implied. Maxim reserves the right to change the circuitry and specifications without notice at any time.

4 _____ Maxim Integrated Products, 120 San Gabriel Drive, Sunnyvale, CA 94086 408-737-7600



Компания «ЭлектроПласт» предлагает заключение долгосрочных отношений при поставках импортных электронных компонентов на взаимовыгодных условиях!

Наши преимущества:

- Оперативные поставки широкого спектра электронных компонентов отечественного и импортного производства напрямую от производителей и с крупнейших мировых складов;
- Поставка более 17-ти миллионов наименований электронных компонентов;
- Поставка сложных, дефицитных, либо снятых с производства позиций;
- Оперативные сроки поставки под заказ (от 5 рабочих дней);
- Экспресс доставка в любую точку России;
- Техническая поддержка проекта, помощь в подборе аналогов, поставка прототипов;
- Система менеджмента качества сертифицирована по Международному стандарту ISO 9001;
- Лицензия ФСБ на осуществление работ с использованием сведений, составляющих государственную тайну;
- Поставка специализированных компонентов (Xilinx, Altera, Analog Devices, Intersil, Interpoint, Microsemi, Aeroflex, Peregrine, Syfer, Eurofarad, Texas Instrument, Miteq, Cobham, E2V, MA-COM, Hittite, Mini-Circuits, General Dynamics и др.);

Помимо этого, одним из направлений компании «ЭлектроПласт» является направление «Источники питания». Мы предлагаем Вам помощь Конструкторского отдела:

- Подбор оптимального решения, техническое обоснование при выборе компонента;
- Подбор аналогов;
- Консультации по применению компонента;
- Поставка образцов и прототипов;
- Техническая поддержка проекта;
- Защита от снятия компонента с производства.



Как с нами связаться

Телефон: 8 (812) 309 58 32 (многоканальный)

Факс: 8 (812) 320-02-42

Электронная почта: org@eplast1.ru

Адрес: 198099, г. Санкт-Петербург, ул. Калинина, дом 2, корпус 4, литера А.