

36V Low Cost High Side Current Sense Amplifier in SOT-23

DESCRIPTION

Demonstration circuit 1240 is a General Purpose High-Side Current-Sense Amplifier featuring the LT6106.

This demo board amplifies an on-board current-sense resistor voltage-drop, providing a precision uni-polar output voltage proportional to load current. The demo circuit includes scaling resistors that program the gain of the circuit to 25V/V. The LT6106 is powered from the same supply that the sense resistor is connected to and provides a ground referenced output. The LT6106 can perform current measurements on supplies ranging from 2.7V to 36V. Since the output voltage is developed as a controlled current through a load resistance, ground-loop errors can be eliminated by simply locating the load

resistor at the destination point (subsequent signal processing such as A/D conversion). Remote loading can be evaluated by simply removing the on board load resistor (R3).

The key performance characteristics of the LT6106 and DC1240 are shown in the Performance Summary below.

Design files for this circuit board are available. Call the LTC factory.

LT, LT are registered trademarks of Linear Technology Corporation. Other product names may be trademarks of the companies that manufacture the products.

PERFORMANCE SUMMARY Specifications are at $T_A = 25^\circ\text{C}$

SYMBOL	PARAMETER	CONDITIONS	MIN	TYP	MAX	UNITS
V_{IN}	Monitored Supply Input Range		2.7	3...28	36	V
V_{MON}	Measurement Output Signal	$I_{OUT} = 5A$		2.5		V
I_{MON}	Measurement Output Signal (current mode)	$I_{OUT} = 5A$, R3 removed		500		μA
I_{OUT}	Output Load Current Range	Thermal limit of R_{SENSE}			7	A
I_{INQ}	V_{IN} Quiescent Current	$V_{IN} = 12V$, $I_{OUT} = 0A$		65		μA
t_R	V_{MON} step-response time	I_{OUT} step from 0A to 5A		5		μs

OPERATING PRINCIPLES

The LT6106 operates by amplifying the voltage drop on a sense resistor placed in series with the power source of a load to be monitored. The sense inputs of the amplifier differentially measure the sense-resistor drop to control an internal variable current source that allows translation of the input information to a level referenced to V_- (ground in this demo circuit). The circuit gain is established by the ratio of the output resistor to the input re-

sistor and is essentially as accurate as the resistors used. In DC1240 as shipped, the sense resistor installed is 20m Ω and the resistor ratio sets the gain to 25V/V, so the nominal output scaling is 500mV per Ampere of load current. Other scalings can be produced by resistor replacement on the demo circuit.

The DC1240 Schematic diagram is shown in Figure 2.

QUICK START PROCEDURE

Demonstration circuit 1240 is easy to set up to evaluate the performance of the LT6106. Refer to Figure 1 for proper measurement equipment setup and follow the procedure below:

1. With power off, connect the power supply positive to IN and the common to GND. This supply should be in the range of 2.7V to 36V. If this supply is not equipped with an accurate current readout, a DMM (set to measure Amperes) may be connected in series with the supply as shown in Figure 1.

NOTE. Be sure that the current capacity of the DMM is adequate to handle the intended load current.

2. Connect a voltmeter or oscilloscope probe to the MON terminal, with the common connection or ground clip tied to GND.
3. Connect a load to the OUT terminal (positive) and return (negative) to the common of the power supply. The load may be a power resistor, active load instrument, or other circuit of interest.
4. Turn on the power supply.
5. Measure an output voltage that corresponds to the load current. $V_{MON} = 0.5 \times I_{OUT}$ for the factory installed resistors.

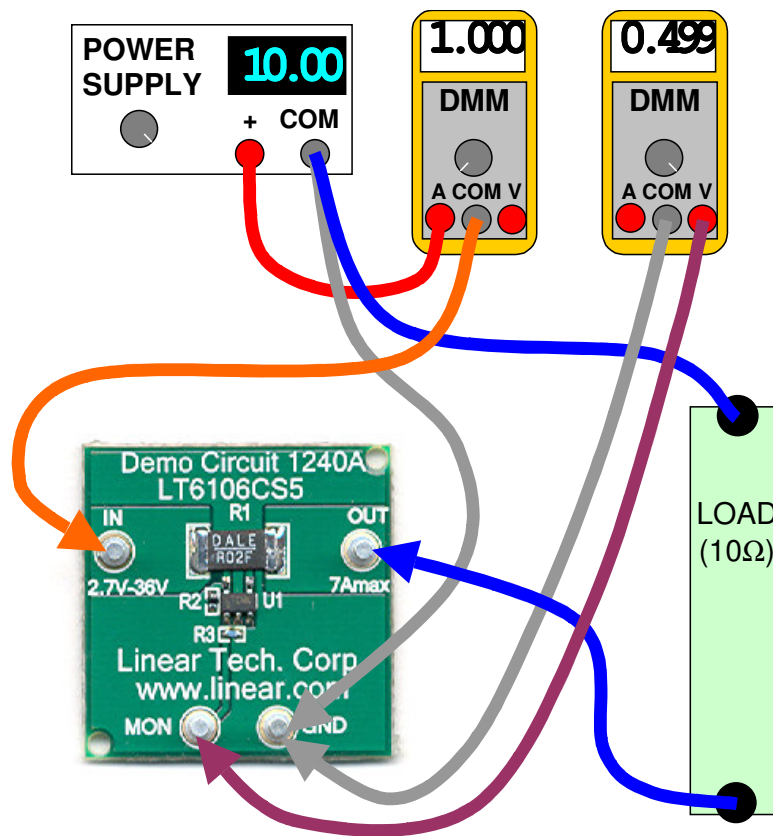

Figure 1. Proper Measurement Equipment Setup

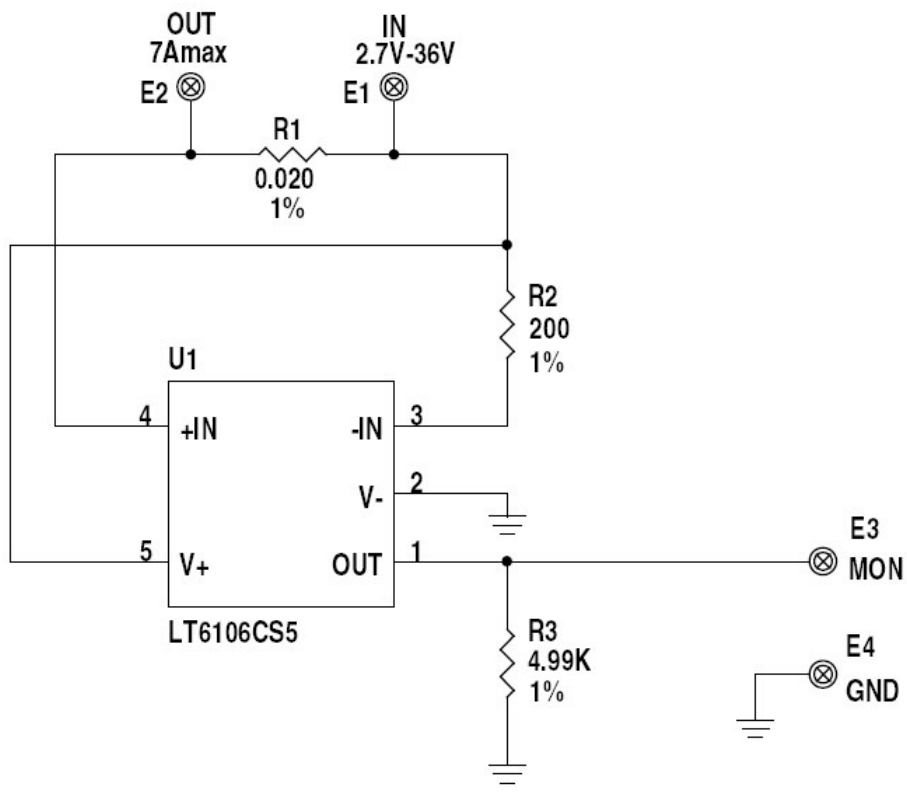

Figure 2. DC1240 Schematic Diagram



Компания «ЭлектроПласт» предлагает заключение долгосрочных отношений при поставках импортных электронных компонентов на взаимовыгодных условиях!

Наши преимущества:

- Оперативные поставки широкого спектра электронных компонентов отечественного и импортного производства напрямую от производителей и с крупнейших мировых складов;
- Поставка более 17-ти миллионов наименований электронных компонентов;
- Поставка сложных, дефицитных, либо снятых с производства позиций;
- Оперативные сроки поставки под заказ (от 5 рабочих дней);
- Экспресс доставка в любую точку России;
- Техническая поддержка проекта, помощь в подборе аналогов, поставка прототипов;
- Система менеджмента качества сертифицирована по Международному стандарту ISO 9001;
- Лицензия ФСБ на осуществление работ с использованием сведений, составляющих государственную тайну;
- Поставка специализированных компонентов (Xilinx, Altera, Analog Devices, Intersil, Interpoint, Microsemi, Aeroflex, Peregrine, Syfer, Eurofarad, Texas Instrument, Miteq, Cobham, E2V, MA-COM, Hittite, Mini-Circuits, General Dynamics и др.);

Помимо этого, одним из направлений компании «ЭлектроПласт» является направление «Источники питания». Мы предлагаем Вам помощь Конструкторского отдела:

- Подбор оптимального решения, техническое обоснование при выборе компонента;
- Подбор аналогов;
- Консультации по применению компонента;
- Поставка образцов и прототипов;
- Техническая поддержка проекта;
- Защита от снятия компонента с производства.



Как с нами связаться

Телефон: 8 (812) 309 58 32 (многоканальный)

Факс: 8 (812) 320-02-42

Электронная почта: org@eplast1.ru

Адрес: 198099, г. Санкт-Петербург, ул. Калинина, дом 2, корпус 4, литера А.