



ON Semiconductor®

<http://onsemi.com>

LV3327PV

Bi-CMOS LSI

Electronic Volume IC

Overview

The LV3327PV is electronic volume LSI for the volume adjustment of the portable sound equipment usage.

Features

- The mixing function is installed, and it is suitable for PND (personal navigation device) as the usage. It is possible to output it by allocating one system in the audio guidance among four input systems, and mixing other signals from the speaker output with the audio guidance by the microcomputer control.
- Because the volume step resolution is 0.5dB step, the volume can be made to fine-tune.
- The loudness function is installed.

Functions

- Input switching : 4 input systems (Independent control is possible.)
- Volume control : +10dB to -79.5dB(0.5dB steps)/-∞
- Loudness control :
Taps are output starting at the -32dB position of the ladder resistor and a loudness function implemented with external capacitor and resistor components.
- Output gain control : 0dB or +6dB select
- Mixing function
- Output switching :
2 outputs (Each Lch output, Rch output, and Lch/Rch mixing output can be selected).
- Each control is done by the serial data input. I²C

LV3327PV

Specifications

Absolute Maximum Ratings at $T_a = 25^\circ\text{C}$, $V_{SS} = 0\text{V}$

Parameter	Symbol	Conditions	Ratings	Unit
Maximum supply voltage	$V_{DD\text{ max}}$	V_{DD}	6	V
Maximum input voltage	$V_{IN\text{ max}}$	All input pins	$V_{SS}-0.3$ to V_{DD}	V
Operating temperature	T_{opr}		-40 to +85	$^\circ\text{C}$
Storage temperature	T_{stg}		-50 to +125	$^\circ\text{C}$

Stresses exceeding Maximum Ratings may damage the device. Maximum Ratings are stress ratings only. Functional operation above the Recommended Operating Conditions is not implied. Extended exposure to stresses above the Recommended Operating Conditions may affect device reliability.

Allowable Operating Ratings at $T_a = 25^\circ\text{C}$, $V_{SS} = 0\text{V}$

Parameter	Symbol	Conditions	Ratings			Unit
			min	typ	max	
Supply voltage	V_{DD}	V_{DD}	3.0	5.0	5.5	V
High-level input voltage	V_{IH}	DATA, CLK	$0.7 V_{DD}$		V_{DD}	V
Low-level input voltage	V_{IL}	DATA, CLK	V_{SS}		$0.2 V_{DD}$	V
Input pulse width	$T_{\phi W}$	CLK	0.6			μsec
Setup time	T_{setup}	DATA, CLK	0.1			μsec
Hold time	T_{hold}	DATA, CLK			0.9	μsec
Operating frequency	fopg	CLK			400	kHz

Electrical Characteristics at $T_a = 25^\circ\text{C}$, $V_{DD} = 5\text{V}$, $V_{SS} = 0\text{V}$

Parameter	Symbol	Conditions	Ratings			Unit
			min	typ	max	
A loss of insertion	ATT		-1.0		+1.0	dB
Input resistance	R_{in}	IN1/IN2/IN3/IN4		50		$\text{k}\Omega$
Volumn step setting error margin	ATerr	+10dB to -40dB	-1.0		+1.0	dB
Total harmonic distortion	THD	$V_{IN} = 1\text{V}_{rms}$, $f = 1\text{kHz}$		0.01		%
Maximum attenuation	$V_{O\text{ min}}$	$V_{IN} = 1\text{V}_{rms}$, $f = 1\text{kHz}$		80		dB
Output noise voltage	V_N	$R_{in} = 1\text{k}\Omega$		5		μV_{rms}
Current drain	I_{DD}			5		mA
Input high-level current	I_{IH}	DATA, CLK, $V_{IN} = 5.0\text{V}$			10	μA
Input low-level current	I_{IL}	DATA, CLK, $V_{IN} = 0\text{V}$	-10			μA
Maximum input voltage	VCL	THD = 1% $R_L = 10\text{k}\Omega$ volumn setting : flat, $f_{IN} = 1\text{kHz}$	1.0			V_{rms}

Package Dimensions

unit : mm (typ)

3178B

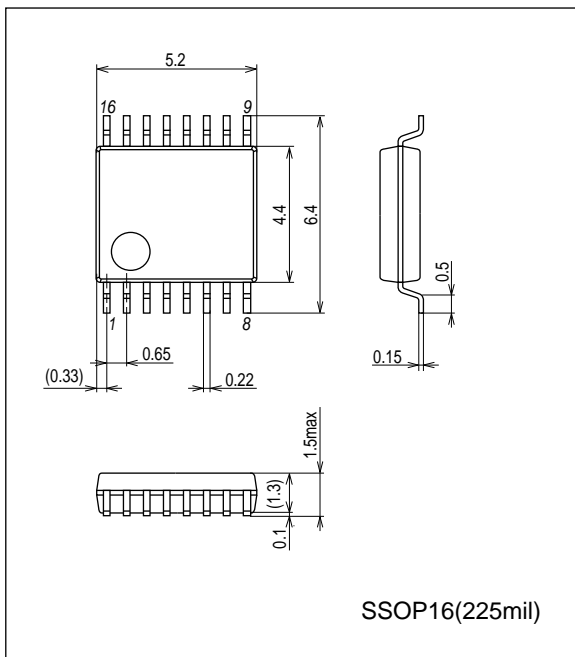

LV3327PV

Pin Assignment

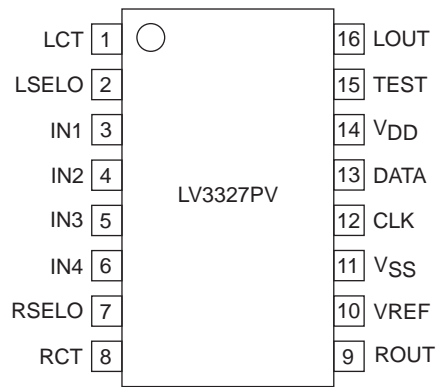

TOP VIEW

Block Diagram

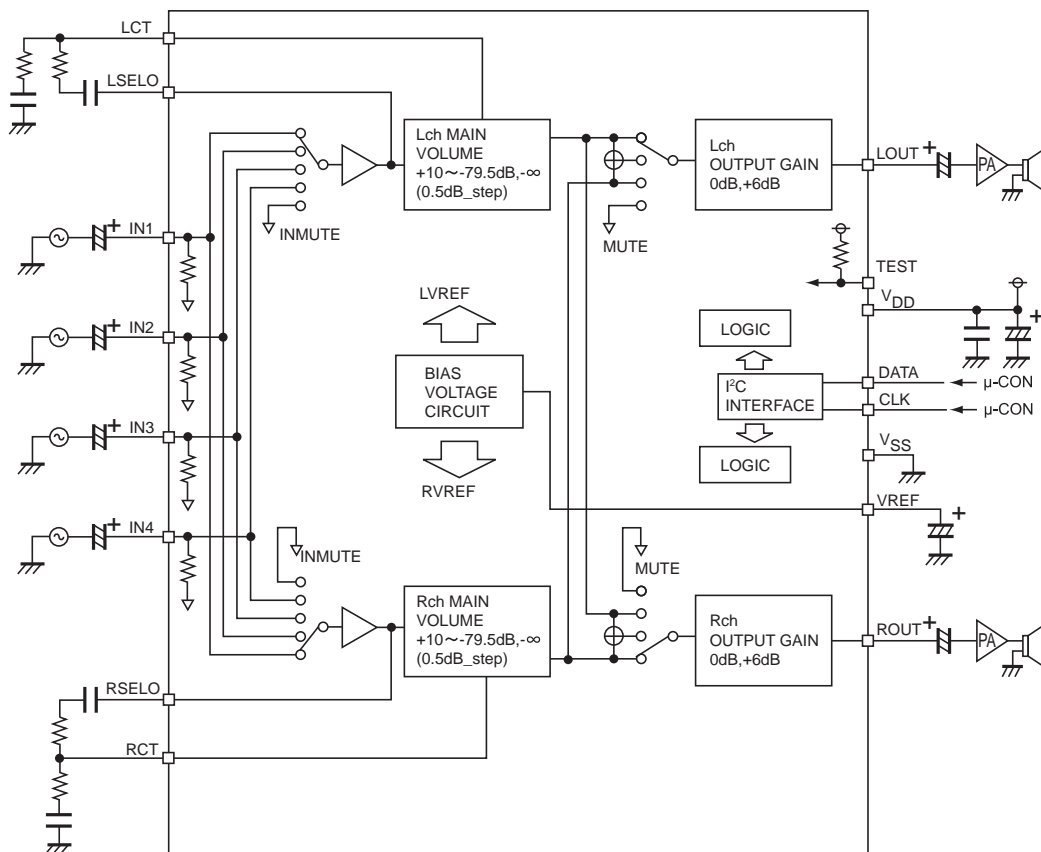

LV3327PV

Pin Functions

Pin	Pin No.	Function	Equivalent Circuit
IN1 IN2 IN3 IN4	3 4 5 6	Input pins.	
LSELO RSELO	2 7	Input selector output pins	
LCT RCT	1 8	Tap pins for external loudness	
LOUT ROUT	16 9	Output pins.	
VREF	10	Connect a capacitor of a few tens of uF between VREF and AVSS (VSS) as a 0.5 × VDD voltage generator, current ripple countermeasure.	
CLK	12	Serial data clock input pin for control.	
DATA	13	Serial data input pin for control.	
TEST	15	TEST pin Normally this pin is OPEN.	
VDD	14	Power supply pin.	
VSS	11	Ground pin.	

LV3327PV

DATA format : I²C data specification

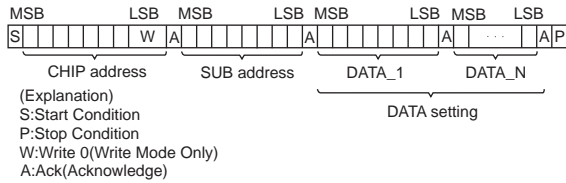

CHIP address

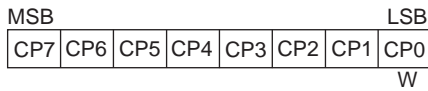

CP7	CP6	CP5	CP4	CP3	CP2	CP1	CP0
1	0	0	0	0	0	1	0

SUB address

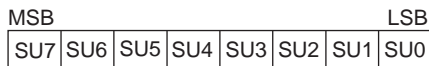

Block	SUB address								
		SU7	SU6	SU5	SU4	SU3	SU2	SU1	SU0
Input switching control (Lch)	DATA_1	1	0	0	0	0	0	0	0
Input switching control (Rch)	DATA_2	0	1	0	0	0	0	0	0
Volume control (Lch)	DATA_5	1	0	1	0	0	0	0	0
Volume control(Rch)	DATA_6	0	1	1	0	0	0	0	0
Loudness	DATA_26	0	1	0	1	1	0	0	0
TEST control	DATA_29	1	0	1	1	1	0	0	0
Output switching control / Output gain control (Lch)	DATA_30	0	1	1	1	1	0	0	0
Output switching control / Output gain control (Rch)	DATA_31	1	1	1	1	1	0	0	0

DATA

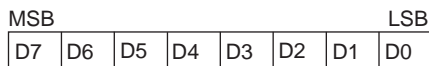

Input switching control (DATA_1, DATA_2)

D7	D6	D5	D4	D3	D2	D1	D0	
								DATA_1: Lch side DATA_2: Rch side
0	0	0	0	0	0	0	0	INMUTE
1	0	0	0	0	0	0	0	IN1 select
0	1	0	0	0	0	0	0	IN2 select
1	1	0	0	0	0	0	0	IN3 select
0	0	1	0	0	0	0	0	IN4 select

LV3327PV

Volume control :10.0dB to -18.0dB (DATA_5, DATA_6)

D7	D6	D5	D4	D3	D2	D1	D0	DATA_5:Lch side DATA_6:Rch side
0	0	1	1	0	1	1	1	10.0dB
1	0	1	1	0	1	1	1	9.5dB
0	1	1	1	0	1	1	1	9.0dB
1	1	1	1	0	1	1	1	8.5dB
0	0	0	0	1	1	1	1	8.0dB
1	0	0	0	1	1	1	1	7.5dB
0	1	0	0	1	1	1	1	7.0dB
1	1	0	0	1	1	1	1	6.5dB
0	0	1	0	1	1	1	1	6.0dB
1	0	1	0	1	1	1	1	5.5dB
0	1	1	0	1	1	1	1	5.0dB
1	1	1	0	1	1	1	1	4.5dB
0	0	0	1	1	1	1	1	4.0dB
1	0	0	1	1	1	1	1	3.5dB
0	1	0	1	1	1	1	1	3.0dB
1	1	0	1	1	1	1	1	2.5dB
0	0	1	1	1	1	1	1	2.0dB
1	0	1	1	1	1	1	1	1.5dB
0	1	1	1	1	1	1	1	1.0dB
1	1	1	1	1	1	1	1	0.5dB
0	0	0	0	0	0	0	0	0dB
1	0	0	0	0	0	0	0	-0.5dB
0	1	0	0	0	0	0	0	-1.0dB
1	1	0	0	0	0	0	0	-1.5dB
0	0	1	0	0	0	0	0	-2.0dB
1	0	1	0	0	0	0	0	-2.5dB
0	1	1	0	0	0	0	0	-3.0dB
1	1	1	0	0	0	0	0	-3.5dB
0	0	0	1	0	0	0	0	-4.0dB
1	0	0	1	0	0	0	0	-4.5dB
0	1	0	1	0	0	0	0	-5.0dB
1	1	0	1	0	0	0	0	-5.5dB
0	0	1	1	0	0	0	0	-6.0dB
1	0	1	1	0	0	0	0	-6.5dB
0	1	1	1	0	0	0	0	-7.0dB
1	1	1	1	0	0	0	0	-7.5dB
0	0	0	0	1	0	0	0	-8.0dB
1	0	0	0	1	0	0	0	-8.5dB
0	1	0	0	1	0	0	0	-9.0dB
1	1	0	0	1	0	0	0	-9.5dB
0	0	1	0	1	0	0	0	-10.0dB
1	0	1	0	1	0	0	0	-10.5dB
0	1	1	0	1	0	0	0	-11.0dB
1	1	1	0	1	0	0	0	-11.5dB
0	0	0	1	1	0	0	0	-12.0dB
1	0	0	1	1	0	0	0	-12.5dB
0	1	0	1	1	0	0	0	-13.0dB
1	1	0	1	1	0	0	0	-13.5dB
0	0	1	1	1	0	0	0	-14.0dB
1	0	1	1	1	0	0	0	-14.5dB
0	1	1	1	1	0	0	0	-15.0dB
1	1	1	1	1	0	0	0	-15.5dB
0	0	0	0	0	1	0	0	-16.0dB
1	0	0	0	0	1	0	0	-16.5dB
0	1	0	0	0	1	0	0	-17.0dB
1	1	0	0	0	1	0	0	-17.5dB
0	0	1	0	0	1	0	0	-18.0dB

LV3327PV

Volume control :-18.5dB to -43.5dB (DATA_5, DATA_6)

D7	D6	D5	D4	D3	D2	D1	D0	DATA_5:Lch side DATA_6:Rch side
1	0	1	0	0	1	0	0	-18.5dB
0	1	1	0	0	1	0	0	-19.0dB
1	1	1	0	0	1	0	0	-19.5dB
0	0	0	1	0	1	0	0	-20.0dB
1	0	0	1	0	1	0	0	-20.5dB
0	1	0	1	0	1	0	0	-21.0dB
1	1	0	1	0	1	0	0	-21.5dB
0	0	1	1	0	1	0	0	-22.0dB
1	0	1	1	0	1	0	0	-22.5dB
0	1	1	1	0	1	0	0	-23.0dB
1	1	1	1	0	1	0	0	-23.5dB
0	0	0	0	1	1	0	0	-24.0dB
1	0	0	0	1	1	0	0	-24.5dB
0	1	0	0	1	1	0	0	-25.0dB
1	1	0	0	1	1	0	0	-25.5dB
0	0	1	0	1	1	0	0	-26.0dB
1	0	1	0	1	1	0	0	-26.5dB
0	1	1	0	1	1	0	0	-27.0dB
1	1	1	0	1	1	0	0	-27.5dB
0	0	0	1	1	1	0	0	-28.0dB
1	0	0	1	1	1	0	0	-28.5dB
0	1	0	1	1	1	0	0	-29.0dB
1	1	0	1	1	1	0	0	-29.5dB
0	0	1	1	1	1	0	0	-30.0dB
1	0	1	1	1	1	0	0	-30.5dB
0	1	1	1	1	1	0	0	-31.0dB
1	1	1	1	1	1	0	0	-31.5dB
0	0	0	0	0	0	1	0	-32.0dB
1	0	0	0	0	0	1	0	-32.5dB
0	1	0	0	0	0	1	0	-33.0dB
1	1	0	0	0	0	1	0	-33.5dB
0	0	1	0	0	0	1	0	-34.0dB
1	0	1	0	0	0	1	0	-34.5dB
0	1	1	0	0	0	1	0	-35.0dB
1	1	1	0	0	0	1	0	-35.5dB
0	0	0	1	0	0	1	0	-36.0dB
1	0	0	1	0	0	1	0	-36.5dB
0	1	0	1	0	0	1	0	-37.0dB
1	1	0	1	0	0	1	0	-37.5dB
0	0	1	1	0	0	1	0	-38.0dB
1	0	1	1	0	0	1	0	-38.5dB
0	1	1	1	0	0	1	0	-39.0dB
1	1	1	1	0	0	1	0	-39.5dB
0	0	0	0	1	0	1	0	-40.0dB
1	0	0	0	1	0	1	0	-40.5dB
0	1	0	0	1	0	1	0	-41.0dB
1	1	0	0	1	0	1	0	-41.5dB
0	0	1	0	1	0	1	0	-42.0dB
1	0	1	0	1	0	1	0	-42.5dB
0	1	1	0	1	0	1	0	-43.0dB
1	1	1	0	1	0	1	0	-43.5dB

LV3327PV

Volume control :-44.0dB to -69.0dB (DATA_5, DATA_6)

D7	D6	D5	D4	D3	D2	D1	D0	DATA_5:Lch side DATA_6:Rch side
0	0	0	1	1	0	1	0	-44.0dB
1	0	0	1	1	0	1	0	-44.5dB
0	1	0	1	1	0	1	0	-45.0dB
1	1	0	1	1	0	1	0	-45.5dB
0	0	1	1	1	0	1	0	-46.0dB
1	0	1	1	1	0	1	0	-46.5dB
0	1	1	1	1	0	1	0	-47.0dB
1	1	1	1	1	0	1	0	-47.5dB
0	0	0	0	0	1	1	0	-48.0dB
1	0	0	0	0	1	1	0	-48.5dB
0	1	0	0	0	1	1	0	-49.0dB
1	1	0	0	0	1	1	0	-49.5dB
0	0	1	0	0	1	1	0	-50.0dB
1	0	1	0	0	1	1	0	-50.5dB
0	1	1	0	0	1	1	0	-51.0dB
1	1	1	0	0	1	1	0	-51.5dB
0	0	0	1	0	1	1	0	-52.0dB
1	0	0	1	0	1	1	0	-52.5dB
0	1	0	1	0	1	1	0	-53.0dB
1	1	0	1	0	1	1	0	-53.5dB
0	0	1	1	0	1	1	0	-54.0dB
1	0	1	1	0	1	1	0	-54.5dB
0	1	1	1	0	1	1	0	-55.0dB
1	1	1	1	0	1	1	0	-55.5dB
0	0	0	0	1	1	1	0	-56.0dB
1	0	0	0	1	1	1	0	-56.5dB
0	1	0	0	1	1	1	0	-57.0dB
1	1	0	0	1	1	1	0	-57.5dB
0	0	1	0	1	1	1	0	-58.0dB
1	0	1	0	1	1	1	0	-58.5dB
0	1	1	0	1	1	1	0	-59.0dB
1	1	1	0	1	1	1	0	-59.5dB
0	0	0	1	1	1	1	0	-60.0dB
1	0	0	1	1	1	1	0	-60.5dB
0	1	0	1	1	1	1	0	-61.0dB
1	1	0	1	1	1	1	0	-61.5dB
0	0	1	1	1	1	1	0	-62.0dB
1	0	1	1	1	1	1	0	-62.5dB
0	1	1	1	1	1	1	0	-63.0dB
1	1	1	1	1	1	1	0	-63.5dB
0	0	0	0	0	0	0	1	-64.0dB
1	0	0	0	0	0	0	1	-64.5dB
0	1	0	0	0	0	0	1	-65.0dB
1	1	0	0	0	0	0	1	-65.5dB
0	0	1	0	0	0	0	1	-66.0dB
1	0	1	0	0	0	0	1	-66.5dB
0	1	1	0	0	0	0	1	-67.0dB
1	1	1	0	0	0	0	1	-67.5dB
0	0	0	1	0	0	0	1	-68.0dB
1	0	0	1	0	0	0	1	-68.5dB
0	1	0	1	0	0	0	1	-69.0dB

LV3327PV

Volume control : -69.5dB to $-\infty$ (DATA_5, DATA_6)

D7	D6	D5	D4	D3	D2	D1	D0	DATA_5:Lch side DATA_6:Rch side
1	1	0	1	0	0	0	1	-69.5dB
0	0	1	1	0	0	0	1	-70.0dB
1	0	1	1	0	0	0	1	-70.5dB
0	1	1	1	0	0	0	1	-71.0dB
1	1	1	1	0	0	0	1	-71.5dB
0	0	0	0	1	0	0	1	-72.0dB
1	0	0	0	1	0	0	1	-72.5dB
0	1	0	0	1	0	0	1	-73.0dB
1	1	0	0	1	0	0	1	-73.5dB
0	0	1	0	1	0	0	1	-74.0dB
1	0	1	0	1	0	0	1	-74.5dB
0	1	1	0	1	0	0	1	-75.0dB
1	1	1	0	1	0	0	1	-75.5dB
0	0	0	1	1	0	0	1	-76.0dB
1	0	0	1	1	0	0	1	-76.5dB
0	1	0	1	1	0	0	1	-77.0dB
1	1	0	1	1	0	0	1	-77.5dB
0	0	1	1	1	0	0	1	-78.0dB
1	0	1	1	1	0	0	1	-78.5dB
0	1	1	1	1	0	0	1	-79.0dB
1	1	1	1	1	0	0	1	-79.5dB
0	0	0	0	0	1	0	1	$-\infty$

Loudness control (DATA_26)

D7	D6	D5	D4	D3	D2	D1	D0	DATA_26
0	0	0	0	0	0	0	0	Loudness: OFF
1	0	0	0	0	0	0	0	Loudness: ON

TEST control (DATA_29)

D7	D6	D5	D4	D3	D2	D1	D0	DATA_29
0	0	0	0	0	0	0	0	Setting usually for operation use

Output switching control / Output gain control (DATA_30, DATA_31)

D7	D6	D5	D4	D3	D2	D1	D0	DATA_30: Lch side DATA_31: Rch side
0	0	0	*	0	0	0	0	MUTE
1	0	0	*	0	0	0	0	Output selector: Lch side select
0	1	0	*	0	0	0	0	Output selector: Rch side select
1	1	0	*	0	0	0	0	Output selector: Lch/Rch mixing select
*	*	0	0	0	0	0	0	Output gain: 0dB setting
*	*	0	1	0	0	0	0	Output gain: 6dB setting

Application Circuit Example

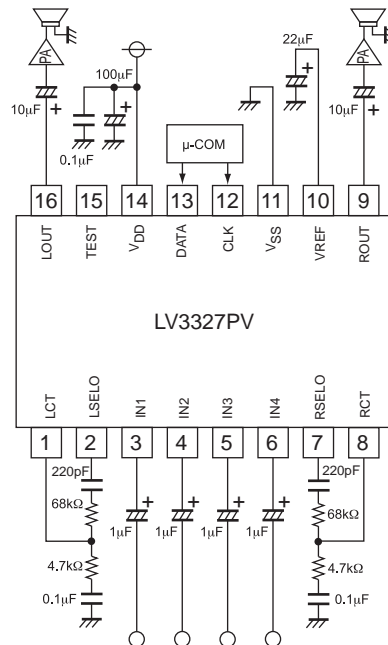

Usage Cautions

(1) Request to send the initial data at power ON

- Though the circuit initializing the IC inside at power ON is incorporated, be sure to send data to all sub-address as the initial data at power ON.
- At power ON, muting or other measures must be taken externally till the data is set.

Reference data

Parameter	Symbol	Conditions	Min	Typ	Max	Unit
VDD power rise time	Trise	0V → 2V power rise time	30	-	-	μsec
VDD voltage when power ON reset is canceled	Vpor		-	2	-	V

(2) Data is switched by standing up about the ACK clock of the data setting bit.

(3) The auto increment function is moved in the SUB address as follows.

...=>DATA_1=>DATA_2=>DATA_5=>DATA_6=>DATA_26=>DATA_29=>DATA_30=>DATA_31=>DATA_1=>...

(4) As for the mixing function, half the value in which the Lch volume output and the Rch volume output are added is output. $(Lch+Rch)/2$. Please set +6dB if necessary in the output steps.

ON Semiconductor and the ON logo are registered trademarks of Semiconductor Components Industries, LLC (SCILLC). SCILLC owns the rights to a number of patents, trademarks, copyrights, trade secrets, and other intellectual property. A listing of SCILLC's product/patent coverage may be accessed at www.onsemi.com/site/pdf/Patent-Marking.pdf. SCILLC reserves the right to make changes without further notice to any products herein. SCILLC makes no warranty, representation or guarantee regarding the suitability of its products for any particular purpose, nor does SCILLC assume any liability arising out of the application or use of any product or circuit, and specifically disclaims any and all liability, including without limitation special, consequential or incidental damages. "Typical" parameters which may be provided in SCILLC data sheets and/or specifications can and do vary in different applications and actual performance may vary over time. All operating parameters, including "Typicals" must be validated for each customer application by customer's technical experts. SCILLC does not convey any license under its patent rights nor the rights of others. SCILLC products are not designed, intended, or authorized for use as components in systems intended for surgical implant into the body, or other applications intended to support or sustain life, or for any other application in which the failure of the SCILLC product could create a situation where personal injury or death may occur. Should Buyer purchase or use SCILLC products for any such unintended or unauthorized application, Buyer shall indemnify and hold SCILLC and its officers, employees, subsidiaries, affiliates, and distributors harmless against all claims, costs, damages, and expenses, and reasonable attorney fees arising out of, directly or indirectly, any claim of personal injury or death associated with such unintended or unauthorized use, even if such claim alleges that SCILLC was negligent regarding the design or manufacture of the part. SCILLC is an Equal Opportunity/Affirmative Action Employer. This literature is subject to all applicable copyright laws and is not for resale in any manner.

Mouser Electronics

Authorized Distributor

Click to View Pricing, Inventory, Delivery & Lifecycle Information:

[ON Semiconductor:](#)

[LV3327PV-TLM-H](#) [LV3327PV-MPB-H](#)



Компания «ЭлектроПласт» предлагает заключение долгосрочных отношений при поставках импортных электронных компонентов на взаимовыгодных условиях!

Наши преимущества:

- Оперативные поставки широкого спектра электронных компонентов отечественного и импортного производства напрямую от производителей и с крупнейших мировых складов;
- Поставка более 17-ти миллионов наименований электронных компонентов;
- Поставка сложных, дефицитных, либо снятых с производства позиций;
- Оперативные сроки поставки под заказ (от 5 рабочих дней);
- Экспресс доставка в любую точку России;
- Техническая поддержка проекта, помощь в подборе аналогов, поставка прототипов;
- Система менеджмента качества сертифицирована по Международному стандарту ISO 9001;
- Лицензия ФСБ на осуществление работ с использованием сведений, составляющих государственную тайну;
- Поставка специализированных компонентов (Xilinx, Altera, Analog Devices, Intersil, Interpoint, Microsemi, Aeroflex, Peregrine, Syfer, Eurofarad, Texas Instrument, Miteq, Cobham, E2V, MA-COM, Hittite, Mini-Circuits, General Dynamics и др.);

Помимо этого, одним из направлений компании «ЭлектроПласт» является направление «Источники питания». Мы предлагаем Вам помощь Конструкторского отдела:

- Подбор оптимального решения, техническое обоснование при выборе компонента;
- Подбор аналогов;
- Консультации по применению компонента;
- Поставка образцов и прототипов;
- Техническая поддержка проекта;
- Защита от снятия компонента с производства.



Как с нами связаться

Телефон: 8 (812) 309 58 32 (многоканальный)

Факс: 8 (812) 320-02-42

Электронная почта: org@eplast1.ru

Адрес: 198099, г. Санкт-Петербург, ул. Калинина, дом 2, корпус 4, литера А.